

# Power Circuit Breaker Uncompromising, Fast and Selective

EntelliGuard\* G Ed. 07





- 2 Product identification
- 3 Features
- 9 Total solution
- 10 Performance ratings

## The breaker

## Intro

Order codes

A

Electronic trip units

B

Breaker accessories

C

Application guide

D

Wiring diagrams

E

Dimensions

F

Numerical index

X



## Product identification

### Power circuit breaker front facia

- ❶ Installed accessory indicators
- ❷ Electronic trip unit
- ❸ Manual charging handle
- ❹ ON and OFF buttons
- ❺ Contact position indicator
- ❻ Ready to close indicator
- ❼ Spring charged indicator
- ❽ Operation counter
- ❾ Provision for key lock
- ❿ Global catalogue number

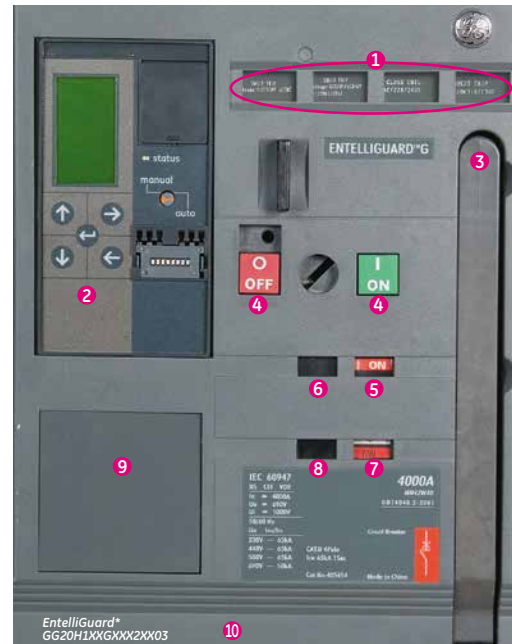

### Power circuit breaker label

- ❶ Product type
- ❷ Bar code with manufacturing data
- ❸ Colour code indicating interruption tier
- ❹ Voltage ratings
- ❺ Current ratings
- ❻ Certification and standards
- ❼ Short-circuit interruption data
- ❽ Manufacturing date

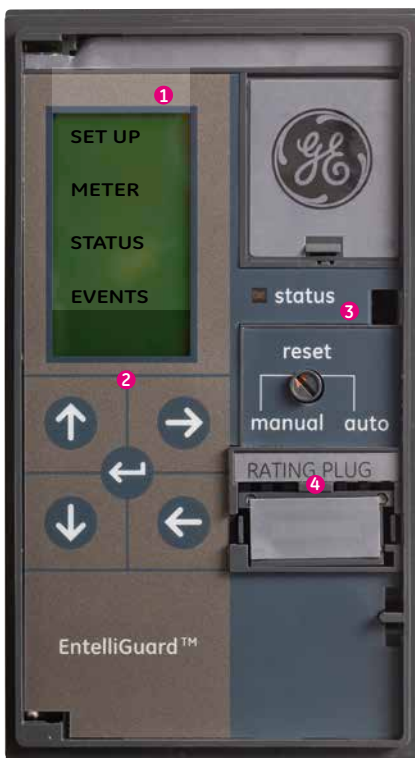
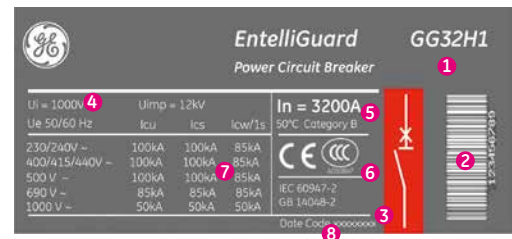

### Advanced electronic trip unit

- ❶ Main screen with the following choices:
  - SETUP**  
Allows adjustment of values and setting of all parameters
  - METER**  
Full measurement values are displayed
  - STATUS**  
Breaker and trip unit position
  - EVENTS**  
History of trip's with indication of fault reason and level and access to the waveform capture function
- ❷ Cursor driven setting system
- ❸ Manual or automatic reset choice
- ❹ Full range rating plug

## Power circuit breakers

Uncompromising, fast and selective



EntelliGuard power circuit breakers are a new line of air circuit breakers evolved from the existing M-PACT Plus and ME07 types to offer a truly global product platform meeting IEC, ANSI and UL standards.

A line of three and four pole devices ranging from 400 to 6400Amp in four basic frames with fault interruption ratings of up to 150kA. A design offering a unique combination of High Fault current withstand ratings, short fault interruption time and selectivity.

The device includes the new state-of-the-art EntelliGuard trip unit that enables the circuit breaker with the latest technology for system safety, reliability, measurement, relaying and communications using the Modbus or Profibus protocol.

### Catalogue content

This catalogue only refers to the IEC versions of the EntelliGuard power circuit breaker. For the ANSI and UL variants of the same design please contact GE Industrial Solutions Plainville CT U.S.A.

## Contents

**Hi-Performance complete line**

**Selective and fast**

**Uncompromising**

**State of the art protection**  
The global trip unit

**Easy to use and flexible**  
Installation options

**Common, field mountable**  
Accessories

**A full solution for**  
low voltage distribution

## Hi-performance: complete line



### Hi-performance: complete line

The EntelliGuard range of power circuit breakers encompasses a line of three and four pole air circuit breakers with nominal currents ranging from 400 to 6400Amp in four basic frames.

All power circuit breakers are designed to allow multiple interruptions of fault currents. Here the tested and certified service breaking capacity value is in almost all cases equal to the stated ultimate breaking capacity.

**Frame T** can be used in networks with voltage up to 690V and can be acquired with current ratings from 400A to 1600Amps at 50°C. This type is available in interruption ratings of 50 and 65kA.

**Frame 1** can be used in networks with voltages up to 1000V and can be acquired with current ratings from 400 to 2000Amps at 50°C. This type is available in interruption ratings (Ics=Icu) of 50 and 65kA.

**Frame 2** can be used in networks with voltages up to 1000V and can be acquired with current ratings from 400 to 4000Amps at 50°C. This type is available in interruption ratings (Ics=Icu) of 50, 65, 85 and 100kA.

**Frame 3** can be used in networks with voltages up to 690V and can be acquired with current ratings from 3200 to 6400Amps at 50°C. This type is available in interruption ratings (Ics=Icu) of 100 and 150kA.

For 1000/1500V DC Switch Please contact your Nearest Sales office

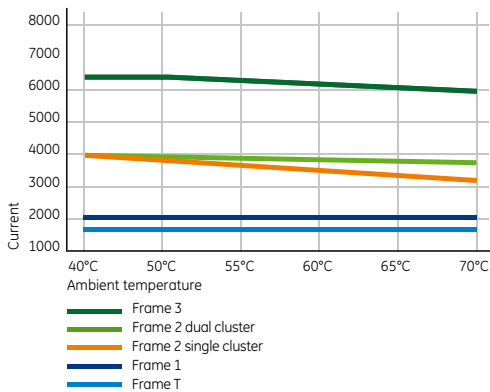
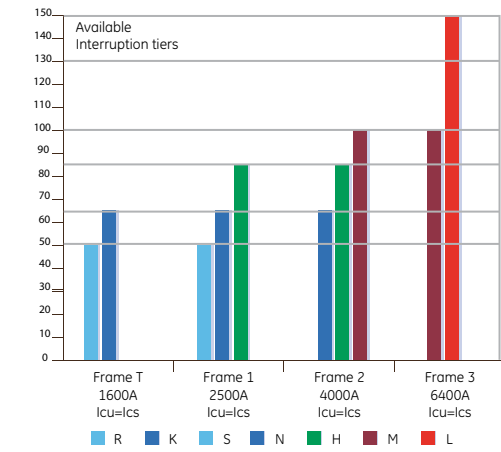

### Hi-performance: current ratings in enclosures

One of the most important user parameters is not the nominal rating of an 'Air Circuit Breaker' in free air but its current rating within a panel or enclosure.

Breakers 'enclosed ratings' are determined by the heat dissipation produced by the device and its ability to carry current at the temperature within the enclosure.

EntelliGuard power circuit breakers have been designed with low Power dissipation values and allow relatively high currents at high ambient temperatures. This is applicable for breakers in the fixed and draw-out pattern as indicated in the graph insert.

For extreme cases a special dual cluster draw-out version of an frame 2 breaker is available allowing a very limited derating when the breaker is used at high ambient temperatures within an enclosure.

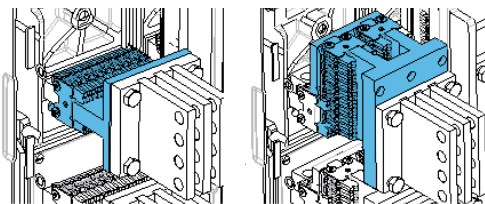

Standard draw-out construction  
'Single Cluster'

'Limited derating'  
draw-out construction  
'Dual Cluster'

## Selective, fast and uncompromising

### Selective and fast

EntelliGuard has been designed to offer an uncompromising combination of a fast interruption at high fault levels attaining values of 40 milliseconds or less whilst maintaining selectivity.

Power circuit breakers are designed to remain closed on a fault. This is for:

- user settable time value when the fault level lies within the range of short time delayed device
- 15 milliseconds when the fault level attains the instantaneous protection range value.

This Instantaneous device includes programming that in normal circumstances waits until the downstream breaker trips.

### Speed WHEN needed ... Warrantied selectivity elsewhere

The simplest, standard, electronic trip unit, has a broad range of timed bands at all overcurrent levels. Thus attaining selectivity between closely rated devices and across multiple distribution levels. This strongly simplifies and economizes installation design.

### Uncompromising ... Reliability

EntelliGuard has been designed as a modern 'Power Circuit Breaker' without neglecting GE's heritage of more than 50 years in building air circuit breakers.

These power circuit breakers uncompromisingly combine the properties of the older M-PACT Plus 1 and 2, ME07 and Wavepro lines with modern state of the art technology.

The result: a device that with a proven electrical and mechanical life span independent of its operation mode: be it manual, electrical or by means of the installed shunt and/or undervoltage releases.

### Uncompromising ... Safety

In order to protect service personnel against the hazards of short circuits whilst working on a power distribution system EntelliGuard power circuit breakers can be equipped with a so called RELT switch input.

This allows the breaker to be switched to its lowest short-circuit settings on service, thus limiting the hazards concerned.

The RELT switch input (with feedback) is available on the breaker auxiliary terminals or can be accessed through the communication bus.

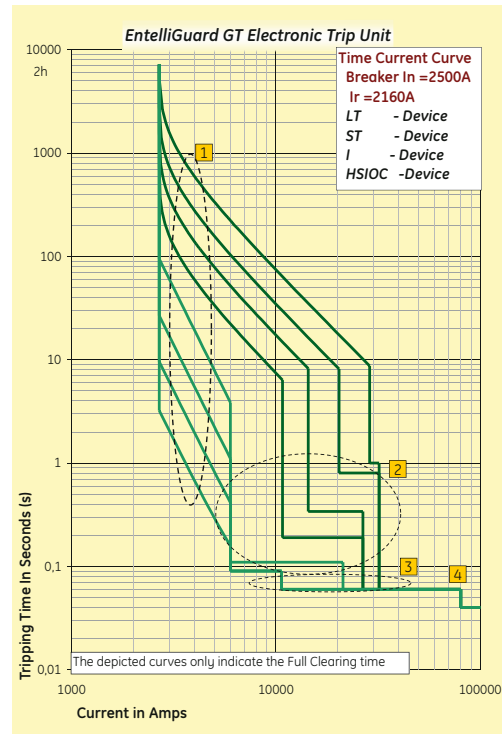

- 1 Overload protection (LT) with 44 bands
- 2 Timed short-circuit protection (STD) with 17 bands
- 3 Selective Instantaneous protection (I)
- 4 Hi-speed trip (HSIOC)

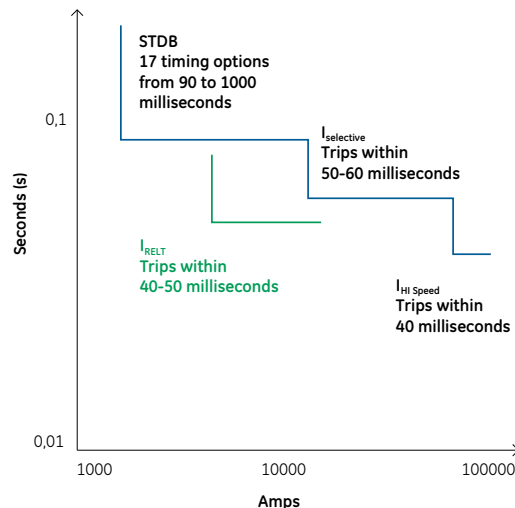

## Protection with State of the art trip units

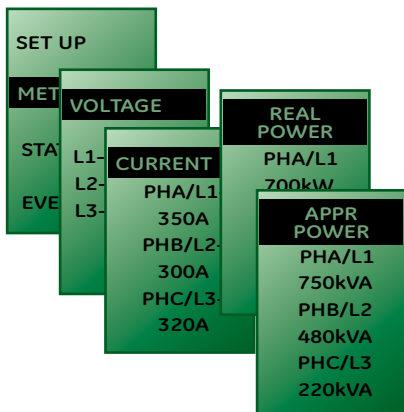
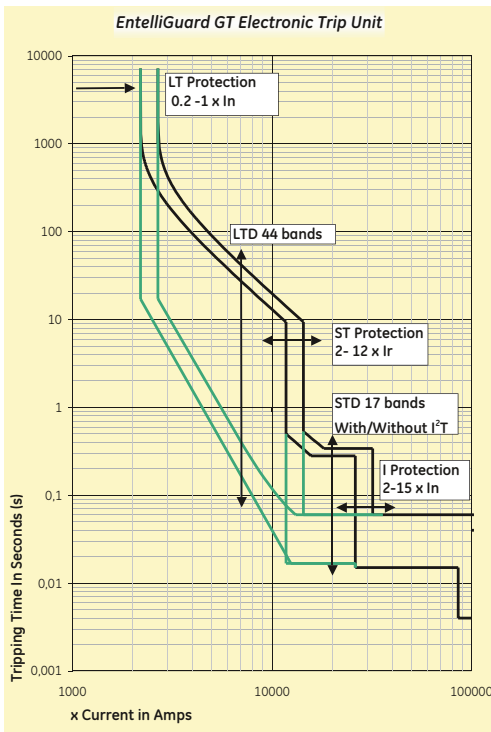

### State of the art electronic trip unit

All EntelliGuard power circuit breakers are equipped with a digital electronic trip unit, available in four basic versions: E, S, N and H. Each has a common design that comes with a screen providing an ammeter and allowing a simple and accurate menu-driven adjustment of the breaker parameters across a broad current range.

All functionality is menu-driven accessed by using 4 setting and one enter key thus allowing a fast and accurate setting of the device. The user can set the device to an automatic or manual reset after a fault.

After inserting the rating plug, the device can be adjusted and the installed options set. As this normally occurs when the installation is not powered up, the use of the separately available TESTER with Power Pack is advised.

### Main adjustment options

#### LT-LTD protection

Each device has an overload setting or LT setting range of 0.2 to 1 times the breaker rating with a choice of more than 60 setting points. The overload protection comes with up to 90 time band settings in 5 distinct curve models allowing the user to configure this device for almost any perceivable application.

#### ST-STD protection

A time delayed short-circuit protection is installed with an adjustment range of 2 to 12 times the set LT current values. The short-circuit interruption time can be set, at one of 17 bands ranging from 90 milliseconds to 1 second.

#### I protection

A switchable instantaneous protection can be optionally installed. This device is adjustable from 2 to 15 or 30 times the rating of the breaker and is programmed to wait for downstream devices to trip before reacting.

#### Other protection features

A host of other protection devices as LT-B & LT-C, RELT, GF sum & GF source return, earthfault (UEF, REF & SEF), extensive protective relays options plus the optional use of energy curves are available (see section B of this catalogue).

#### Measurement, relaying and communication

The EntelliGuard trip unit has been envisaged to provide the user with more. Optionally a full network measurement device can be installed on the device. Relays can be included to trip the breaker on Voltage unbalance, current unbalance, power reversal etc.

The device can be equipped with communication for use with the Modbus or Profibus protocol whilst events as overload, short-circuit and ground-faults can be tracked. Optionally the user can portray a short-circuit event through the Wave Form Capture option.

#### Plug 'n Play

Electronic trip units are normally supplied factory fitted. However spares are available that plug into the breaker, automatically read the main breaker data and adjust themselves automatically to the breaker type.

This option can be used to allow field replacement or upgrades of existing trip units OR can allow the user to acquire breakers in kit form and customize them locally.



## Power circuit breakers Easy to install and versatile

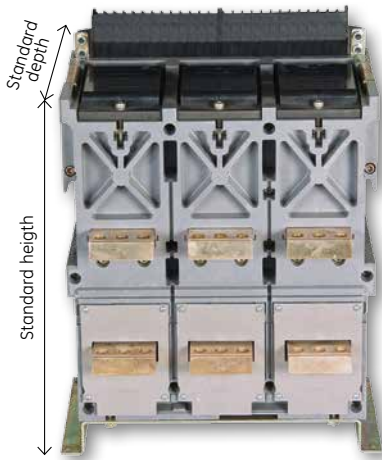

### Easy to install

EntelliGuard power circuit breakers are available in a fixed and draw-out pattern. Each pattern offering the highest possible current rating when enclosed in a panel or equipment.

Independent of the number of poles, rated current or interruption rating, each of the two patterns has a common height, depth and cut-out dimension. This strongly simplifying the design of panels and equipment in which these devices are used<sup>(1)</sup>.

The basic breaker width has been optimized to allow for space to connect in- and outgoing bus bars and cables. Both fixed and draw-out power circuit breaker types are supplied with rear connections suitable for rear access horizontal busbar connection.

The breakers are installed by using easily accessible mounting brackets, the drilling pattern of which exactly matches that of the previous M-PACT Plus line.

All accessories are wired out to an easy to access 39 or 78 pole terminal strip mounted on the breaker top. These terminals are amply sized to allow the use of up to 2.5 mm<sup>2</sup> cabling and can be used with standard connection materials or AMP type plug connectors.

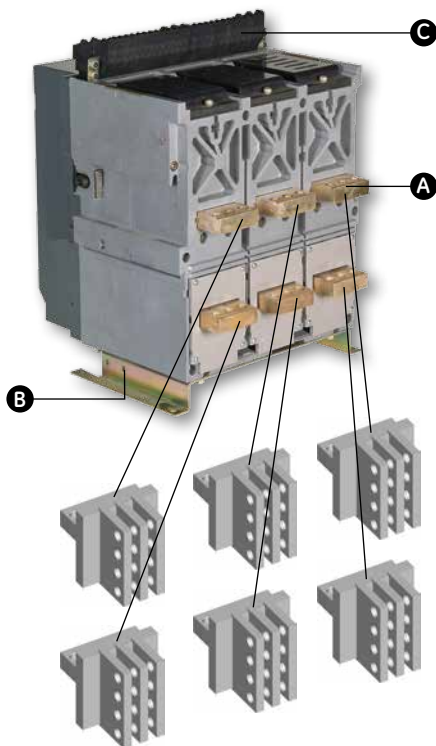

### Flexible ... Kit form

A power circuit breaker is normally supplied completely fitted OFF works. However the unique modular construction and field mountable trip unit and accessories option can be used to acquire a breaker in kit form and to customize the device locally<sup>(2)</sup>.

### Flexible ... Connections

Besides the standard horizontal connection options multiple other options are available.

Power circuit breakers supplied in a fixed pattern can be optionally supplied with rear vertical connections or front access connections<sup>(3)</sup>.

The cassettes of the breakers in draw-out pattern are supplied with T or L stubs suitable for horizontal busbar connection. However these stubs can be rotated 90 degrees allowing the user to change the cassette connection option from horizontal to vertical busbars.

A 2nd cassette version is available allowing front access connection<sup>(3)</sup>.

- A** Standard horizontal rear connections
- B** Mounting bracket
- C** Terminal strip

(1) The width does vary  
(2) With GE training  
(3) Maximum 4000Amps

Draw-out Breakers with Cassettes 'With No Rear Copper' can also be supplied upon request

## Common field mountable accessories



### Common internal accessories

A large range of internal accessories as electrical operators, up to four shunt releases, closing coils or undervoltage releases, interlock coils, auxiliary and alarm contacts, carriage switches, coil indication contacts and breaker status switches are available.

The power circuit breaker front facia includes 'pop up' indicators that provide the user with an overview as to which accessories are installed in the device.

Each of these devices can be acquired factory fitted or is available in a field mountable execution. The design is common to all four frames.

- 1 Electrical operator
- 2 Bell alarm switch
- 3 A max of 4 closing coils, shunt or undervoltage releases
- 4 Electronic trip unit
- 5 A maximum of 8 auxiliary switches
- 6 Ready to close or spring charged contact

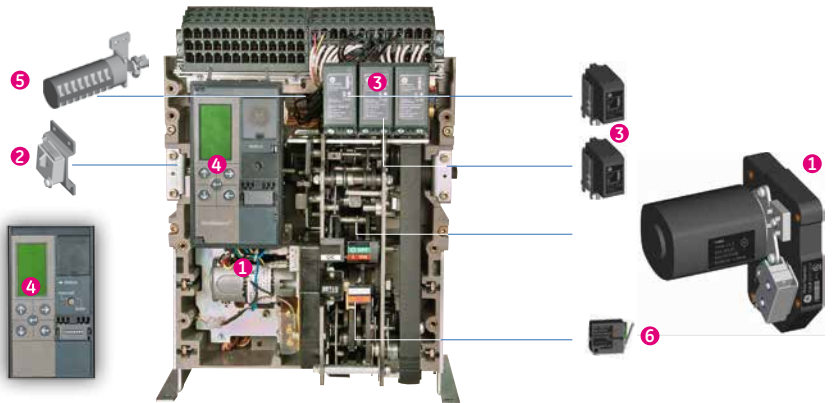

### Common external accessories

Multiple common external accessories are available, a full overview of which can be found in section C of this catalogue.

On the left the key lock and breaker interlock options are portrayed. Here up to four Ronis, Profalux or Castell locks can be used to lock the breaker, and up to two Ronis / Flat shapped or Profalux / Star Shaped locks to lock the draw-out breaker in its cassette.

Optionally groups of two or three power circuit breakers in fixed or draw-out pattern can be interlocked. This in several different configurations, allowing the user to build an incoming power supply of multiple breakers to his own requirements.

All Interlocks and Locking devices are only supplied factory fitted, the associated locks and cables are field mountable.

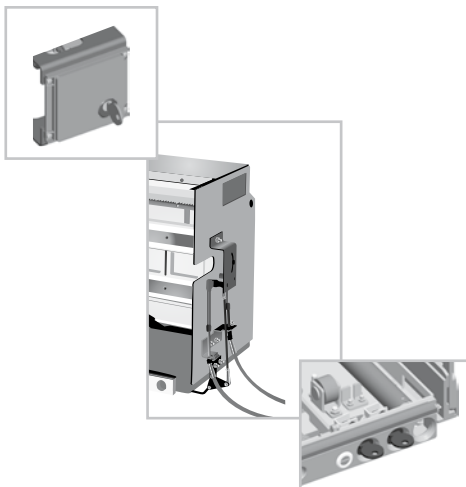

## Power circuit breakers Part of a total solution



Using world class design and development tools like Six Sigma, computer simulation and Lean manufacturing, the EntelliGuard is intended to meet and exceed the most stringent quality and safety standards. At GE we are proud to offer a product that will offer years of reliable and dependable protection.

GE's name is synonymous with a broad range of products designed to meet our customer's changing and competitive environment. Our drive to exceed our customer's expectations is the foundation for continual renewal of our commitment to provide innovative low voltage solutions.

The new EntelliGuard and the existing ElfaPlus, Record Plus and Surion breaker and starter lines offer a full line of **high-performance** protection devices.

They provide a fully co-ordinated approach to circuit and device protection for use in the domestic, commercial and industrial environment.

GE's new lines meet the latest technical standards and regulations and have been certified by authorities as Lovag, the KEMA and Lloyd's. The components in these lines have been designed to be an integral part of a solution. A complete low voltage distribution and control range including components, accessories and the distribution and controls equipment they fit into.

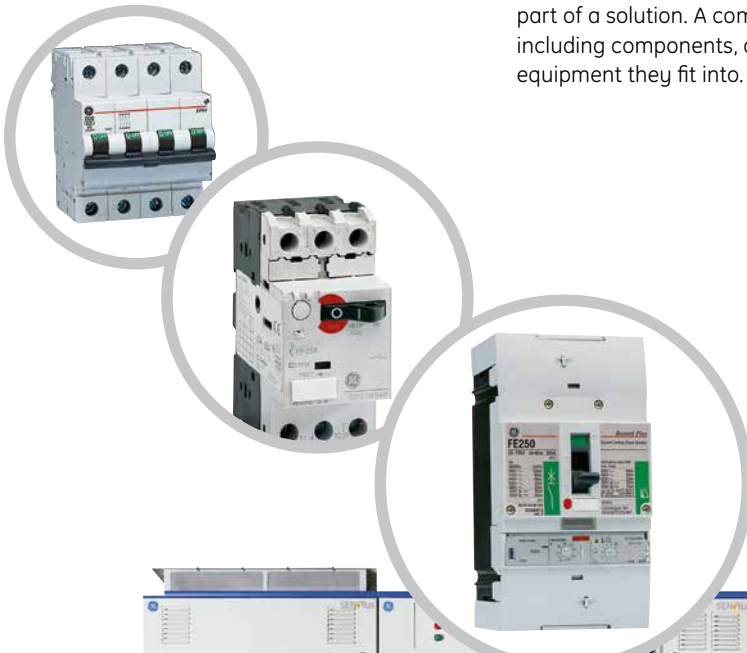

## EN 60947-2 standard

Power circuit breaker type		GT04			GG04				GT07			GG07					
Air circuit breaker denomination		R	K	S	N	H	E	M	R	K	S	N	H	E	M		
Poles	Number of	3, 4						3, 4									
Rated insulation voltage	Ui (Volts)	1000			1000	1000	1000	1000			1000	1000	1000				
Rated impulse withstand voltage	Uimp (Kilovolt)	12						12									
Rated operational voltage Ue	Volts AC	690			1000	690	1000	690			1000	690	1000				
Category of use		B						B									
Suitable for use as an isolator	Positive ON & OFF	YES						YES									
Rated current In	A at 50°C	400						630									
Ultimate breaking capacity Icu (kA)	230/240V-440V AC	50	65	50	65	85	85	100	65	65	50	65	85	85	100		
	500V AC	50	50	50	65	65	85	100	50	50	50	65	65	85	100		
	690V AC	42	42	40	50	65	85	85	42	42	40	50	65	85	85		
	1000V AC <sup>(1)</sup>					35		50					35		50		
Service breaking capacity Ics (kA)	230/240V-440V AC	50	50	50	65	85	85	100	50	50	50	65	85	85	100		
	500V AC	50	50	50	65	65	85	100	50	50	50	65	65	85	100		
	690V AC	42	50	40	50	65	85	85	42	42	40	50	65	85	85		
	1000V AC <sup>(1)</sup>					35		50					35		50		
Short-circuit withstand Icw (kA)	1 second	42	50	50	65	85	85	100	42	50	50	65	85	85	100		
	3 seconds	30	30	42	50	50	50	50	30	30	42	50	50	50	50		
Short-circuit making current Icm 220-500V AC	kA Peak	105	105 <sup>(2)</sup>	105	143	187	187	220	105	105 <sup>(2)</sup>	105	143	187	187	220		
Short-circuit making current Icm 690V AC	kA Peak	88.2	88.2	88.2	105	143	187	187	88.2	88.2	88.2	105	143	187	187		
Mechanical endurance (CO operations at 440V AC)	With maintenance	20000				20000				20000				20000			
	Without maintenance	12500				10000				12500				10000			
Electrical endurance (CO operations at 440V AC)	Without maintenance	6000	10000	6000	10000			5000	6000	10000	6000	10000			5000		
Single phase breaking capacity I <sub>1r</sub> (kA)	230/240-500V AC		30			32.5		50		30			32.5		50		
	690V AC		24			32.5		50		24			32.5		50		

## Electronic trip units

GT -E type with Ammeter	LT & ST, - GF		X		X
GT -S type with Ammeter, optional communication	LT, ST, I or HI - GF		X		X
GT -N type with measurement, optional communication	LT, ST, I or HI, RELT GF, ZSI		X		X
GT -H type with measurement & relaying, optional communication	LT or LT+, ST, I or HI, RELT GFsum or GFct., ZSI		X		X

## EN 60947-3 standard

Power Circuit Breaker type		G704		GJ04				G707		GJ07			
				Non Auto						Non Auto			
		R		S	N		M	R		S		M	
Isolator denomination													
Poles	Number of	3, 4		3, 4	3, 4		3, 4	3, 4		3, 4		3, 4	
Rated insulation voltage	Ui (Volts)	1000		1000	1000		1000	1000		1000		1000	
Rated impulse withstand voltage	Uimp (Kilovolt)	12		12	12		12	12		12		12	
Rated operational voltage Ue	Volts AC	690		690	690		1000	690		690		1000	
Category of use		B		B	B		B	B		B		B	
Suitable for use as an isolator	Positive ON & OFF	YES		YES	YES		YES	YES		YES		YES	
Rated current In	A at 50°C	400		400	400		400	400		630		630	
Short-circuit withstand Icw (kA)	1 second	42		50	65		85	42		50		85	
	3 seconds	30		42	50		50	30		42		50	
Short-circuit making current Icm 220-500V AC	kA Peak	75		88.2	143		187	75		88.2		187	
Mechanical endurance (CO operations at 440V AC)	With maintenance	20000		20000	20000		20000	20000		20000		20000	
	Without maintenance	12500		12500	12500		10000	12500		12500		10000	
Electrical endurance (CO operations at 440V AC)	Without maintenance	6000		10000	10000		10000	6000		10000		10000	

## DC-Switch -EN 60947-3 standard<sup>(5)</sup>

Switch type		G704		GJ04				G707		GJ07			
Isolator Denomination													
Poles	Number of												
Rated insulation voltage	Ui Volts												
Rated Operational Voltage	Volts DC												
Rated Current In													
Utilisation category													

## Installation

Fixed pattern		G704		GJ04				G707		GJ07			
Dimensions in mm	Height	442	442	442	442	442	442	442	442	442	442	442	
	Width 3 pole	258	258	342	342	432	258	258	342	342	432	432	
	Width 4 pole	328	328	442	442	562	328	328	442	442	562	562	
	Depth <sup>(3)</sup>	328	328	328	328	328	328	328	328	328	328	328	
Available connection modes	Rear horizontal	X	X	X	X	X	X	X	X	X	X	X	
	Rear vertical	X	X	X	X	X	X	X	X	X	X	X	
	Front	X	X	X	X	X	X	X	X	X	X	X	
Weights in Kg	3 pole	32	43	32	43	53	32	43	32	43	53		
	4 pole	39	54	39	54	68	39	54	39	54	68		
Draw-out pattern		G704		GJ04				G707		GJ07			
Dimensions in mm	Height	444	444	444	444	444	444	444	444	444	444	444	
	Width 3 pole	250	250	343	343	443	250	250	343	343	443	443	
	Width 4 pole	320	320	443	443	573	320	320	443	443	573	573	
	Depth <sup>(3)</sup>	453	453	453	453	453	453	453	453	453	453	453	
Available connection modes	Rear universal <sup>(4)</sup>	X	X	X	X	X	X	X	X	X	X	X	
	Front	X	X	X	X	X	X	X	X	X	X	X	
	Weights in Kg	55	82	55	82	131	55	82	55	82	131		
	4 pole	66	100	66	100	164	66	100	66	100	164		

(1) For use at 1000Vac phase separators are required

(2) Making capacity is 143kA peak at voltages ≤ 440V AC

(3) With horizontal rear connections; indicated depth value is the required panel dimension

(4) T stubs can be rotated and used for both vertical and horizontal rear connection

(5) For More details Please refer to DC Switch Brochure

GT08		GG08						GT10		GG10						GT13		GG13					
R	K	S	N	H	E	M	R	K	S	N	H	E	M	R	K	S	N	H	E	M			
		3, 4								3, 4								3, 4					
1000		1000		1000	1000	1000	1000		1000		1000	1000	1000	1000		1000		1000	1000	1000			
12		12		12		12		12		12		12		12		12		12		12			
690		1000		690	1000	1000	690		1000		690	1000	1000	690		1000		690	1000	690	1000		
B		B		B		B		B		B		B		B		B		B		B			
YES		YES		YES		YES		YES		YES		YES		YES		YES		YES		YES			
800		800		800		800		1000		1000		1000		1250		1250		1250		1250			
50	65	50	65	85	85	100	50	65	50	65	85	85	100	65	65	50	65	85	85	100			
50	50	50	65	65	85	100	50	50	50	65	65	85	100	50	50	50	65	65	85	100			
42	42	40	42	65	85	85	42	42	40	50	65	85	85	42	42	40	50	65	85	85			
				35		50					35		50					35		50			
50	50	50	65	85	85	100	50	50	50	65	85	85	100	50	50	50	65	85	85	100			
50	50	50	65	65	85	100	50	50	50	65	65	85	100	50	50	50	65	65	85	100			
42	42	40	50	65	85	85	42	42	40	50	65	85	85	42	42	40	50	65	85	85			
				35		50					35		50					35		50			
42	50	50	65	85	85	85	42	50	50	65	85	85	85	42	50	50	65	65	85	85			
30	30	42	50	50	50	50	30	30	42	50	50	50	50	30	30	42	50	50	50	50			
105	105 <sup>(a)</sup>	105	143	187	187	220	105	105 <sup>(a)</sup>	105	143	187	187	220	105	105 <sup>(a)</sup>	105	143	187	187	220			
88.2	88.2	88.2	105	143	187	187	88.2	88.2	105	143	187	187	220	88.2	88.2	88.2	105	143	187	187			
		20000		20000		10000	20000		20000		20000		10000	20000		20000		20000		10000			
		12500		10000		5000	12500		10000		5000		12500		10000		5000		10000				
6000	10000	6000	10000		5000	6000	10000	6000	10000		5000	6000	10000	6000	10000		5000	10000		5000			
		30			32.5			50			30			32.5			50			30			
		24			32.5			50			24			32.5			50			24			

		X						X						X					
		X						X						X					
		X						X						X					
		X						X						X					

G708	GJ08				G710	GJ10				G713	GJ13			
R	Non Auto		Non Auto		R	Non Auto		Non Auto		R	Non Auto		Non Auto	
S	N	M	S	N	M	S	N	M	S	N	M	S	N	M
3, 4	3, 4	3, 4	3, 4	3, 4	3, 4	3, 4	3, 4	3, 4	3, 4	3, 4	3, 4	3, 4	3, 4	3, 4
1000	1000	1000	1000	1000	1000	1000	1000	1000	1000	1000	1000	1000	1000	1000
12	12	12	12	12	12	12	12	12	12	12	12	12	12	12
690	690	690	690	690	690	690	690	690	690	690	690	690	690	690
B	B	B	B	B	B	B	B	B	B	B	B	B	B	B
YES	YES	YES	YES	YES	YES	YES	YES	YES	YES	YES	YES	YES	YES	YES
800	800	800	800	800	800	1000	1000	1000	1000	1000	1250	1250	1250	1250
42	50	65	85	42	85	42	50	65	85	42	50	65	85	42
30	42	50	50	30	50	30	42	50	50	30	42	50	50	30
75	88.2	143	187	75	187	75	88.2	143	187	75	88.2	143	187	75
20000	20000	20000	20000	20000	20000	20000	20000	20000	20000	20000	20000	20000	20000	20000
12500	12500	12500	10000	12500	10000	12500	12500	10000	12500	10000	12500	12500	10000	12500
6000	10000	10000	10000	6000	10000	10000	10000	10000	10000	10000	10000	10000	10000	10000

G708	GJ08		G710	GJ10		G713	GJ13	
N	T	N	T	N	T	N	T	
3, 4	4	3, 4	4	3, 4	4	3, 4	4	
1000	1500	1000	1500	1000	1500	1000	1500	
1000	1500	1000	1500	1000	1500	1000	1500	
800	800	1250	1250	1250	1250	1250	1250	
DC-22A		DC-22A		DC-22A		DC-22A		

442	442	442	442	442	442	442	442	442	442	442	442	442	442	442
258	258	342	342	432	258	258	342	342	432	258	258	342	342	432
328	328	442	442	562	328	328	442	442	562	328	328	442	442	562
328	328	328	328	328	328	328	328	328	328	328	328	328	328	328
X	X	X	X	X	X	X	X	X	X	X	X	X	X	X
X	X	X	X	X	X	X	X	X	X	X	X	X	X	X
X	X	X	X	X	X	X	X	X	X	X	X	X	X	X
32	43	32	43	53	32	43	32	43	53	32	43	32	43	53
39	54	39	54	68	39	54	39	54	68	39	54	39	54	68
444	444	444	444	444	444	444	444	444	444	444	444	444	444	444
250	250	343	343	443	250	250	343	343	443	250	250	343	343	443
320	320	443	443	573	320	320	443	443	573	320	320	443	443	573
453	453	453	453	453	453	453	453	453	453	453	453	453	453	453
X	X	X	X	X	X	X	X	X	X	X	X	X	X	X
X	X	X	X	X	X	X	X	X	X	X	X	X	X	X
55	82	55	82	131	55	82	55	82	131	55	82	55	82	131
66	100	66	100	164	66	100	66	100	164	66	100	66	100	164



## EN 60947-2 standard

Power circuit breaker type		GT16		GG16					GG20				
Air circuit breaker denomination		R	K	S	N	H	E	M	S	N	H	E	M
Poles	Number of	3, 4											
Rated insulation voltage	Ui (Volts)	1000			1000	1000	1000	1000	1000	1000	1000	1000	1000
Rated impulse withstand voltage	Uimp (Kilovolt)	12											
Rated operational voltage Ue	Volts AC	690			1000	690	1000	690	1000	690	1000	690	1000
Category of use		B											
Suitable for use as an isolator	Positive ON & OFF	YES											
Rated current In	A at 50°C	1600											
Ultimate breaking capacity Icu (kA)	230/240V-440V AC	50	65	50	65	85	85	100	50	65	85	85	100
	500V AC	50	50	50	65	65	85	100	50	65	65	85	100
	690V AC	42	42	40	50	65	85	85	40	50	65	85	85
	1000V AC <sup>(1)</sup>					35		50			35		50
Service breaking capacity Ics (kA)	230/240V-440V AC	50	50	50	65	85	85	100	50	65	85	85	100
	500V AC	50	50	50	65	65	85	100	50	65	65	85	100
	690V AC	42	42	40	50	65	85	85	40	50	65	85	85
	1000V AC <sup>(1)</sup>					35		50			35		50
Short-circuit withstand Icw (kA)	1 second	42	50	42	65	65	85	85	50	65	65	85	85
	3 seconds	30	30	42	50	50	50	50	50	50	50	50	50
Short-circuit making current Icm 220-500V AC	kA Peak	105	105 <sup>(2)</sup>	105	143	187	187	220	105	143	187	187	220
Short-circuit making current Icm 690V AC	kA Peak	88.2	88.2	88.2	105	143	187	187	84	105	143	187	187
Mechanical endurance (CO operations at 440V AC)	With maintenance	20000					20000	10000	20000		20000	10000	
	Without maintenance	12500					10000	5000	12500		10000	5000	
Electrical endurance (CO operations at 440V AC)	Without maintenance	6000	10000	6000	10000		5000		8000		6000	5000	
Single phase breaking capacity I <sub>ir</sub> (kA)	230/240-500V AC		30			32.5		50			32.5		50
	690V AC		24			32.5		50			32.5		50

## Electronic trip units

GT -E type with Ammeter	LT & ST, - GF				X					X		
GT -S type with Ammeter, optional communication	LT, ST, I or HI - GF				X					X		
GT -N type with measurement, optional communication	LT, ST, I or HI, RELT GF, ZSI				X					X		
GT -H type with measurement & relaying, optional communication	LT or LT+, ST, I or HI, RELT GFsum or GFct., ZSI				X					X		

## EN 60947-3 standard

Power circuit breaker type		G716		GJ16					GJ20				
		R		Non Auto				Non Auto					
Isolator denomination				S	N			M	S	N		M	
Poles	Number of	3, 4		3, 4	3, 4			3, 4	3, 4	3, 4		3, 4	
Rated insulation voltage	Ui (Volts)	1000		1000	1000			1000	1000	1000		1000	
Rated impulse withstand voltage	Uimp (Kilovolt)	12		12	12			12	12	12		12	
Rated operational voltage Ue	Volts AC	690		690	690			1000	690	690		1000	
	Volts DC							1000				1000	
Category of use		B		B	B			B	B	B		B	
Suitable for use as an isolator	Positive ON & OFF	YES		YES	YES			YES	YES	YES		YES	
Rated current In	A at 50°C	1600		1600	1600			1600	2000	2000		2000	
Short-circuit withstand Icw (kA)	1 second	42		50	65			85	50	65		85	
	3 seconds	30		40	50			50	40	50		50	
Short-circuit Making current Icm 220-500V AC	kA Peak	75		88.2	143			187	88.2	143		187	
Mechanical endurance (CO operations at 440V AC)	With maintenance	20000		20000	20000			20000	20000	20000		10000	
	Without maintenance	12500		12500	12500			10000	12500	12500		5000	
Electrical endurance (CO operations at 440V AC)	Without maintenance	6000		10000	10000			10000	8000	8000		5000	

## DC-Switch -EN 60947-3 standard<sup>(8)</sup>

Switch type		G716		GJ16					GJ20				
Isolator Denomination				N		T			N		T		
Poles	Number of			3, 4	4				3, 4	4			
Rated insulation voltage	Ui Volts			1000	1500				1000	1500			
Rated Operational Voltage	Volts DC			1000	1500				1000	1500			
Rated Current In				1600	1600				2000	2000			
Utilisation category				DC-22A					DC-22A				

## Installation

Fixed pattern												
Dimensions in mm	Height	442	442	442	442	442	442	442	442	442	442	442
	Width 3 pole	258	258	342	342	342	342	432	342	342	432	432
	Width 4 pole	328	328	442	442	442	442	562	442	442	562	562
	Depth <sup>(5)</sup>	328	328	328	328	328	328	328	328	328	328	328
Available connection modes	Rear horizontal	X	X	X	X	X	X	X	X	X	X	X
	Rear vertical	X	X	X	X	X	X	X	X	X	X	X
	Front	X	X	X	X	X	X	X	X	X	X	X
Weights in Kg	3 pole	32	43	32	43	43	43	53	43	43	53	53
	4 pole	39	54	39	54	54	54	68	54	54	68	68
Draw-out pattern												
Dimensions in mm	Height	444	444	444	444	444	444	444	444	444	444	444
	Width 3 pole	250	250	342	343	343	343	443	343	343	443	443
	Width 4 pole	320	320	443	443	443	443	573	443	443	573	573
	Depth <sup>(5)</sup>	453	453	453	453	453	453	453	453	453	453	453
Available connection modes	Rear universal <sup>(6)</sup>	X	X	X	X	X	X	X	X	X	X	X
	Front	X	X	X	X	X	X	X	X	X	X	X
Weights in Kg	3 pole	55	82	55	82	82	82	131	82	82	131	131
	4 pole	66	100	66	100	100	100	164	100	100	164	164

(1) For use at 1000Vac phase separators are required

(2) Making capacity is 143kA peak at voltages ≤ 440V AC

(3) GH and GK types ("Limited derating types") are only available in draw-out pattern in vertical connection mode draw-out pattern in vertical connection mode

(4) Rated for 3000A

(5) With indicated depth value is the required panel dimension (breaker dimension indicated with horizontal rear connections)



GG25					GG32 and GH32 <sup>(1)</sup>					GG40 and GH40 <sup>(1)</sup>					GG50		GG64	
S	N	F	H	M	N	H	M	G	L	N	H	M	G	L	M	L	M	L
3, 4					3, 4					3, 4					3, 4		3, 4	
1000					1000					1000					1000		1000	
12					12					12					12		12	
690					690					690					690		690	
B					B					B					B		B	
YES					YES					YES					YES		YES	
2500					3200					4000					5000		6400	
50	65	85	85	100	65	85	100	100	150	65	85	100	100	150	100	150	100	150
50	65	65	85	100	65	85	100	100	130	65	85	100	100	130	100	130	100	130
40	50	65	85	85	50	85	85	100	100	50	85	85	100	100	100	100	100	100
35					50					50								
50	65	85	85	100	65	85	100	100	150	65	85	100	100	150	100	150	100	150
50	65	65	85	100	65	85	100	100	130	65	85	100	100	130	100	130	100	130
40	50	65	85	85	50	85	85	100	100	50	85	85	100	100	100	100	100	100
35					50					50								
50	65	65	85	85	65	85	85	100	100	65	85	85	100	100	100	100	100	100
50	50	50	50	50	50	50	50	85	85	50	50	50	85	85	85	85	85	85
105	143	187	187	220	143	187	220	220	330	143	187	220	220	330	220	330	220	330
84	105	143	187	187	105	187	187	220	220	105	187	187	220	220	220	220	220	220
20000					20000					20000					20000		20000	
12500					10000					5000					5000		5000	
8000					5000					2500					2500		1500	
32,5					50					50					65		65	
32,5					50					50					65		65	

Intro

GJ25				GJ32 and GK32 <sup>(1)</sup>				GJ40 and GK40 <sup>(1)</sup>				GJ50		GJ64	
Non Auto				Non Auto				Non Auto				Non Auto		Non Auto	
S	N	M	N	M	N	L	N	M	L	M	L	L	L	L	L
3, 4	3, 4	3, 4	3, 4	3, 4	3, 4	3, 4	3, 4	3, 4	3, 4	3, 4	3, 4	3, 4	3, 4	3, 4	3, 4
1000	1000	1000	1000	1000	1000	1000	1000	1000	1000	1000	1000	1000	1000	1000	1000
12	12	12	12	12	12	12	12	12	12	12	12	12	12	12	12
690	690	1000	690	1000	690	690	690	1000	690	1000	690	690	690	690	690
		1000		1000				1000		1000					
B	B	B	B	B	B	B	B	B	B	B	B	B	B	B	B
YES	YES	YES	YES	YES	YES	YES	YES	YES	YES	YES	YES	YES	YES	YES	YES
2500	2500	2500	3200	3200		5000	4000	4000	5000	4000	5000	5000	6400		
50	65	85	65	85		100	65	85	100	85	100	100	100	100	100
42	50	50	50	50		85	50	50	85	50	85	85	85	85	85
88,2	143	187	143	187		220	143	187	220	187	220	220	220	220	220
20000	20000	10000	20000	10000		10000	20000	10000	10000	10000	10000	10000	10000	10000	10000
12500	10000	5000	10000	5000		5000	10000	5000	5000	5000	5000	5000	5000	5000	5000
8000	6000	5000	5000	5000		1500	5000	5000	1500	5000	1500	1500	1500	1500	1500

GJ25			GJ32		
N	T		N	T	
3, 4	4		3, 4	4	
1000	1500		1000	1500	
1000	1500		1000	1500	
2500	2500		3200	3200	
DC-22A			DC-22A		

442	442	442	442	442	442	442	442	442	442	442
342	432	342	432	432	432	737	432	737	737	737
442	562	442	562	562	562	967	562	967	967	967
328	328	328	328	328	328	328	328	328	328	328
X	X	X	X	X	X	X	X	X	X	X
X	X	X	X	X	X	X	X	X	X	X
X	X	X	X	X	X	X	X	X	X	X
43	53	43	53	53	53	90	53	90	90	90
54	68	54	68	68	68	115	68	115	115	115

444	444	444	444	444	444	444	444	444	444	444
434	443	343	443	443	443	743	443	743	743	743
443	573	443	573	573	573	973	573	973	973	973
453	453	453	453	453	453	488	488	488	488	488
X	X	X	X	X	X	X	X	X	X	X
X	X	X	X	X	X	X	X	X	X	X
82	131	82	131	131	131	220	131	220	220	220
100	164	100	164	164	164	275	164	275	275	275

(6) T stubs can be rotated and used for both vertical and horizontal rear connection  
 (7) T stubs can only be used for vertical rear connections  
 (8) For More details Please refer to DC Switch Brochure



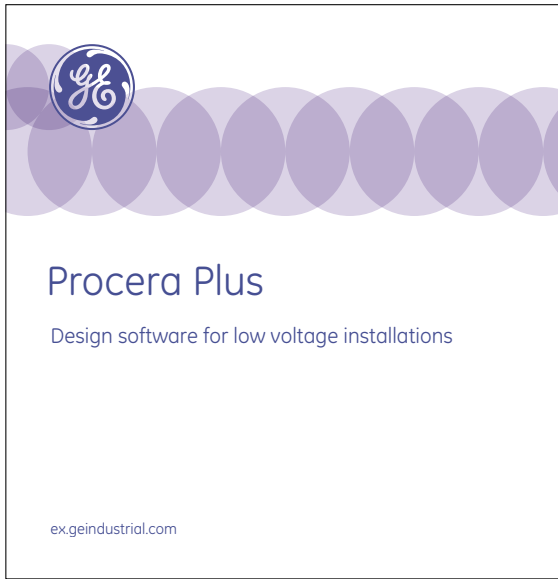

### Application software

The new HD 384<sup>(1)</sup> and R064-03 standards require that the design of a low voltage distribution system includes the determination of all prospective short-circuit and fault currents levels.

GE has developed a windows based software package to do this 'Procera Plus': a multi-standard and multi-lingual software package to accompany our new product line.

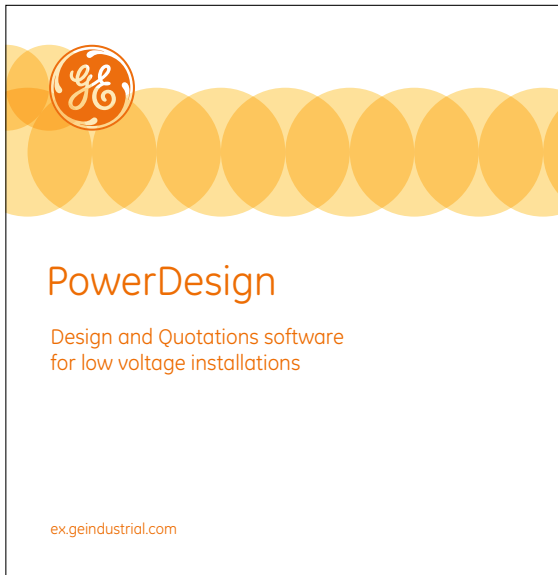

### Design software

GE provides a software package PowerDesign to configure the widely used and well known GE system enclosure ranges 'QuiXtra\* 630', 'QuiXtra\* 4000' and 'SEN Plus', and to use them with components as electrical distribution panels. This software provides the user with a varied and simple range of user friendly tools and features to design and configure devices and enclosures following an electrical component mounting logic. PowerDesign package also includes a tool that allows the user to configure the new EntelliGuard power circuit breaker, its catalogue code and also defines the subcomponents of which it is built. A New EntelliGuard Global Configurator is also available which allows the user to easily configure catalog numbers and obtain price. This tool can be accessed by using a laptop or mobile device. Please contact your nearest GE representative for the link.

(1) Also available in IEC 60364 version



### Trip Unit Toolkit

#### EntelliGuard manager toolkit

- Compatible with GTU, PremEon S, and MET trip units
- One-to-one connection with trip unit
- WaveForm capture/test available on standard version only
- 407999/GTUTK20 (testkit) is required for interfacing with EntelliGuard trip unit.
- Software free and could be downloaded from this website: <http://www.geindustrial.com/products/conversion-kits-and-trip-units/trip-unit-toolkit>



## Power circuit breakers

- A.2 EntelliGuard: How to order in 8 steps
- A.4 Basic breakers executed in a fixed mounting pattern
- A.6 Isolators or non automatic breakers in a fixed mounting pattern
- A.7 Termination sets for breakers and Isolators in fixed mounting pattern
- A.9 Basic breakers: draw-out breakers; moving portion only
- A.12 Isolators or non automatic breakers: draw-out patterns; moving portion only
- A.14 Cassettes for use with breakers and Isolators in draw-out pattern; factory mounted
- A.16 Trip units; factory mounted

The breaker

Order codes

## Internal accessories

- A.22 Factory mounted
- A.25 Field mountable
- A.28 Installation accessories
- A.30 Sensors for trip units
- A.31 Cassettes for use with breakers and Isolators in draw-out pattern; field mountable
- A.33 Field mounted (spare) trip units
- A.34 Spare parts

Electronic trip units

Breaker accessories

Application guide

Wiring diagrams

Dimensions

## Global catalogue number structure

- A.36 Breaker
- A.40 Cassette

Numerical index

## Valid catalogue number combinations

- A.41 3 pole breakers - Fixed mounting pattern and draw-out pattern
- A.42 4 pole breakers - Fixed mounting pattern
- A.43 4 pole breakers - Draw-out pattern

Intro

A

B

C

D

E

F

X



# How to order

Order codes	Step 1	Step 2			Step 3				Step 4
	Choose current rating	Choose required interruption rating			Define if a breaker or isolator is needed Proceed to establish the first 5 digits of the catalogue number as indicated here				Select the required product
	In	Icu	Ics	Icw	Frame	Standard		Limited derating	
		≤ 440V AC				Breaker	Isolator <sup>(1)</sup>	Breaker	Isolator <sup>(1)</sup>
A	400A	50kA	50kA	42kA	T	GT04R	G704R		
		65kA	50kA	50kA	T	GT04K			
		50kA	50kA	50kA	1	GG04S	GJ04S		
		65kA	65kA	65kA	1	GG04N	GW04N		
		85kA	85kA	65kA	1	GG04H			
		85kA	85kA	85kA	2	GG04E	GW04M		
		100kA	100kA	85kA	2	GG04M			
B	630A	50kA	50kA	42kA	T	GT07R	G707R		
		65kA	50kA	50kA	T	GT07K			
		50kA	50kA	50kA	1	GG07S	GJ07S		
		65kA	65kA	65kA	1	GG07N	GW07N		
		85kA	85kA	65kA	1	GG07H			
		85kA	85kA	85kA	2	GG07E	GW07M		
		100kA	100kA	85kA	2	GG07M			
C	800A	50kA	50kA	42kA	T	GT08R	G708R		
		65kA	50kA	50kA	T	GT08K			
		50kA	50kA	50kA	1	GG08S	GJ08S		
		65kA	65kA	65kA	1	GG08N	GW08N		
		85kA	85kA	65kA	1	GG08H			
		85kA	85kA	85kA	2	GG08E	GW08M		
		100kA	100kA	85kA	2	GG08M			
D	1000A	50kA	50kA	42kA	T	GT10R	G710R		
		65kA	50kA	50kA	T	GT10K			
		50kA	50kA	50kA	1	GG10S	GJ10S		
		65kA	65kA	65kA	1	GG10N	GW10N		
		85kA	85kA	65kA	1	GG10H			
		85kA	85kA	85kA	2	GG10E	GW10M		
		100kA	100kA	85kA	2	GG10M			
E	1250A	50kA	50kA	42kA	T	GT13R	G713R		
		65kA	50kA	50kA	T	GT13K			
		50kA	50kA	50kA	1	GG13S	GJ13S		
		65kA	65kA	65kA	1	GG13N	GW13N		
		85kA	85kA	65kA	1	GG13H			
		85kA	85kA	85kA	2	GG13E	GW13M		
		100kA	100kA	85kA	2	GG13M			
F	1600A	50kA	50kA	42kA	T	GT16R	G716R		
		65kA	50kA	50kA	T	GT16K			
		50kA	50kA	50kA	1	GG16S	GJ16S		
		65kA	65kA	65kA	1	GG16N	GW16N		
		85kA	85kA	65kA	1	GG16H			
		85kA	85kA	85kA	2	GG16E	GW16M		
		100kA	100kA	85kA	2	GG16M			
X	2000A	50kA	50kA	50kA	1	GG20S	GJ20S		
		65kA	65kA	65kA	1	GG20N	GW20N		
		85kA	85kA	65kA	1	GG20H			
		85kA	85kA	85kA	2	GG20E	GW20M		
		100kA	100kA	85kA	2	GG20M			
		50kA	50kA	50kA	1	GG25S	GJ25S		
		85kA	85kA	65kA	1	GG25F	GW25F		
	2500A	65kA	65kA	65kA	2	GG25N	GJ25N		
		85kA	85kA	85kA	2	GG25H	GW25M		
		100kA	100kA	85kA	2	GG25M			
		65kA	65kA	65kA	2	GG32N	GJ32N	GH32N	GK32N
		85kA	85kA	85kA	2	GG32H	GW32M	GH32H	GZ32H
		100kA	100kA	85kA	2	GG32M		GH32M	
		100kA	100kA	100kA	3	GG32G	GJ32L		
	3200A	150kA	150kA	100kA	3	GG32L			
		65kA	65kA	65kA	2	GG40N	GJ40N	GH40N	GK40N
		85kA	85kA	85kA	2	GG40H	GW40M	GH40H	GZ40H
		100kA	100kA	85kA	2	GG40M		GH40M	
		100kA	100kA	100kA	3	GG40G	GJ40L		
		150kA	150kA	100kA	3	GG40L			
		100kA	100kA	100kA	3	GG50M	GJ50L		
	5000A	150kA	150kA	100kA	3	GG50L			
		100kA	100kA	100kA	3	GG64M	GJ64L		
		150kA	150kA	100kA	3	GG64L			

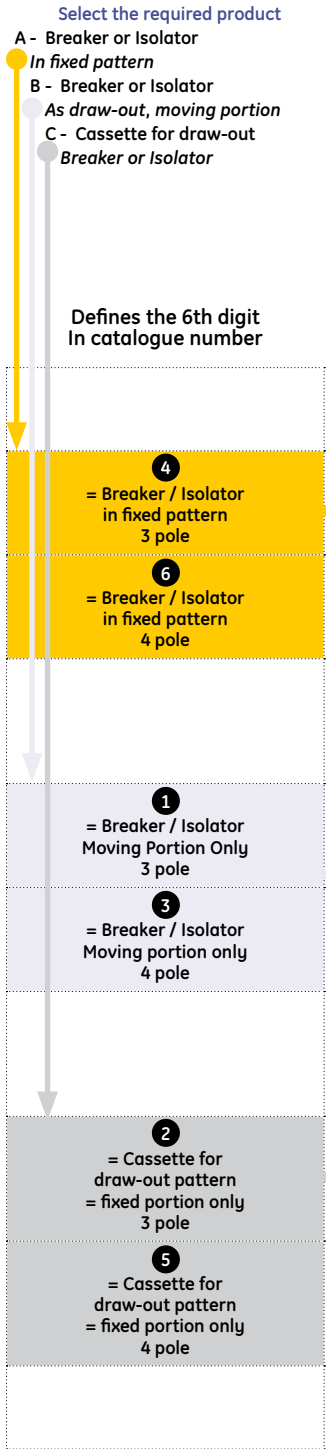

(1) On isolators Icu and Ics values do not apply

**Examples**

Breaker 4p 1600A draw-out portion only- Icu=85kA, Ics=lcw=65kA: **GG16H3**

Breaker 3p 3200A fixed pattern - horizontal rear connections - Icu=Ics=lcw=65kA: **GG32N4**



# in 8 steps

**Step 5**

Finalize the basic catalogue number see catalogue pages:  
 A.4-A.5 - Fixed pattern  
 A.9-A.11 - Draw-out portion  
 A.7 - Connections fixed pattern  
 A.14 - Cassettes, draw-out

**Completing the basic catalogue number**

<p>No addition                  Indicates breaker / isolator                  In fixed pattern                  has set of 3NO/3NC aux.                  Contacts included                  Breaker in fixed pattern                  are equipped with                  rear connection (horizontal).                  Other options include                  rear (vertical)                  and front (flat)                  See page A.7 to order                  field mountable                  adaptation kits</p> <p>See pages A.4, 5 &amp; 6</p>
<p>No addition                  Indicates breaker / isolator                  Moving portion only                  has set of 3NO/3NC aux.                  Contacts included</p> <p>See pages A.9, 10 &amp; 11</p>
<p><b>U</b>                  = Cassette with                  universal 'T stabs' suited for use                  as horizontal or vertical rear                  connections                  Safety Shutters                  Supplied with cassette<sup>(2)</sup></p>
<p><b>V</b>                  = Cassette with                  vertical rear connections                  Safety Shutters                  Supplied with cassette<sup>(2)</sup></p>
<p><b>F</b>                  = Cassette with                  front flat connections                  Safety Shutters                  Supplied with cassette<sup>(2)</sup></p> <p>See page A.14</p>

**Step 6**

Basic catalogue number is  
 a manually operated device  
 If a motor operated device is  
 requested?  
 Please order  
 Motor and closing coils as  
 indicated here<sup>(2)</sup>

**Add catalogue number(s)**

<p>If chosen device is a breaker or                  isolator frame T</p> <p>See page A.22                  Order a motor Type T                  and 1 closing coil or                  1 command closing coil                  based on voltage                  requirements                  and specifications</p>
<p>If chosen device is                  a breaker or isolator                  frame 1</p> <p>See page A.22                  Order a motor Type1                  and 1 closing coil or                  1 command closing coil                  based on voltage                  requirements                  and specifications</p>
<p>If chosen device is                  a breaker or isolator                  frame 2 or 3</p> <p>See page A.22                  Order a motor type 2                  and 1 closing coil or                  1 command closing coil                  based on voltage                  requirements                  and specifications</p>

**Step 7**

If universal internal  
 accessories<sup>(2)</sup> are needed?  
 Options  
 UVR or SHT release(s)  
 Network interlocks  
 Auxiliary contacts  
 Alarm and signal contacts

**Add catalogue number(s)**

<p>If chosen device is                  a breaker or isolator                  See page A.22</p> <p>To add up to 3 SHT or UVR                  releases                  or 1 network interlock                  coils and 1 SHT or UVR                  release</p>
<p>If chosen device is                  a breaker or isolator                  See page A.22</p> <p>To extend on the installed                  3 NO + 3NC contacts                  Maximum of 8 possible</p>
<p>If chosen device is                  a breaker or isolator                  See page A.22</p> <p>To add bell alarm and/or                  coils signalling contacts</p>
<p>If chosen device is                  a cassette                  See page A.22 &amp; A.23</p> <p>To add position indication                  contacts in cassette                  or provisions for key interlocks</p>

**Step 8**

Full catalogue number defines:  
 a breaker without trip unit  
 For all breakers ADD  
 Trip unit

**Add catalogue number(s)**

<p>If chosen device is                  a Breaker                  See pages A.16 to A.21                  Choose and add a trip unit out of                  the the four basic types and                  39 different options.</p>
<p>Offering</p> <p>An extremely large setting range                  covering overload, delayed and                  instantaneous short-circuit                  protection</p> <p>Groundfault protection in single                  or dual mode suited for                  applications as UEF, REF and SEF                  or combinations thereof</p> <p>Complete and sophisticated                  network measurement options,                  including wave form capture</p> <p>Multiple relaying options as zone                  selective interlock, undervoltage,                  overvoltage, reverse power etc.</p>

**- Or -**

A 2nd ordering method can be used in which the fully configured breaker or cassette is defined in one character string. This string comprises 18 digits when used for the breaker and 12 for when used for the cassette.

This global ordering code is referred to within GE as the:

**catalogue number**

It is used on all relevant ordering documents and printed on each EntelliGuard breaker front fascia. An explanation of this code and its use can be found on page A.32 of this catalogue.

When ordering with the method indicated here our CRC department will define and confirm the mentioned individual **catalogue number**.

(2) Devices ordered here are supplied factory fitted







Remark: for field mountable accessories see page A.24 to A.31



## Basic breakers executed in a fixed mounting pattern

- With horizontal rear connection (for other options, please refer to page A.7)<sup>(1)</sup>
- With aux. contact block equipped with 3 NO and 3 NC contacts
- Basic breaker MUST be equipped with a trip unit (for options, please refer to page A.16 to A.21)
- For 1000V applications (M type under 5000A) phase separators are required (see page A.27)

### Fixed mounting pattern



	Rating (A)	3 pole		4 pole Left Neutral		4 pole Right Neutral	
		Cat. No.	Ref. No.	Cat. No.	Ref. No.	Cat. No.	Ref. No.
 <p><b>R type</b> Icu = Ics = 50kA Icw = 42kA</p>	400	GT04R4	444542	GT04R6	444563	GT04R5	444740
	630	GT07R4	444543	GT07R6	444564	GT07R5	444741
	800	GT08R4	444544	GT08R6	444565	GT08R5	444742
	1000	GT10R4	444545	GT10R6	444566	GT10R5	444743
	1250	GT13R4	444546	GT13R6	444567	GT13R5	444744
	1600	GT16R4	444547	GT16R6	444568	GT16R5	444745
 <p><b>S type</b> Icu = Ics = Icw 50kA</p>	400	GG04S4	407019	GG04S6	407020	GG04S5	408379
	630	GG07S4	407048	GG07S6	407049	GG07S5	408399
	800	GG08S4	407078	GG08S6	407079	GG08S5	408439
	1000	GG10S4	407108	GG10S6	407109	GG10S5	408449
	1250	GG13S4	407138	GG13S6	407139	GG13S5	408459
	1600	GG16S4	407168	GG16S6	407169	GG16S5	408499
	2000	GG20S4	407208	GG20S6	407209	GG20S5	408519
	2500	GG25S4	410655	GG25S6	410657	GG25S5	410656
 <p><b>K type</b> Icu = 65kA Ics = Icw = 50kA</p>	400	GT04K4	444548	GT04K6	444569	GT04K5	444746
	630	GT07K4	444549	GT07K6	444570	GT07K5	444747
	800	GT08K4	444550	GT08K6	444571	GT08K5	444748
	1000	GT10K4	444551	GT10K6	444572	GT10K5	444749
	1250	GT13K4	444552	GT13K6	444573	GT13K5	444750
	1600	GT16K4	444553	GT16K6	444574	GT16K5	444751
 <p><b>N type</b> Icu = Ics = Icw 65kA</p>	400	GG04N4	407015	GG04N6	407016	GG04N5	408377
	630	GG07N4	407044	GG07N6	407045	GG07N5	408397
	800	GG08N4	407074	GG08N6	407075	GG08N5	408437
	1000	GG10N4	407104	GG10N6	407105	GG10N5	408447
	1250	GG13N4	407134	GG13N6	407135	GG13N5	408457
	1600	GG16N4	407164	GG16N6	407165	GG16N5	408497
	2000	GG20N4	407204	GG20N6	407205	GG20N5	408517
	2500	GG25N4	407244	GG25N6	407245	GG25N5	408530
	3200	GG32N4	407266	GG32N6	407267	GG32N5	408549
4000 <sup>(1)</sup>	GG40N4	407292	GG40N6	407293	GG40N5	408569	
 <p><b>F type</b> Icu = Ics = 85kA Icw = 65kA</p>	2500	GG25F4	410658	GG25F6	410660	GG25F5	410659
 <p><b>H type</b> Icu = Ics = 85kA Icw = 65kA</p>	400	GG04H4	407007	GG04H6	407008	GG04H5	408373
	630	GG07H4	407036	GG07H6	407037	GG07H5	408393
	800	GG08H4	407066	GG08H6	407067	GG08H5	408433
	1000	GG10H4	407096	GG10H6	407097	GG10H5	408443
	1250	GG13H4	407126	GG13H6	407127	GG13H5	408453
	1600	GG16H4	407156	GG16H6	407157	GG16H5	408493
	2000	GG20H4	407196	GG20H6	407197	GG20H5	408513
 <p><b>E-H type</b> Icu = Ics = Icw 85kA</p>	400	GG04E4	407003	GG04E6	407004	GG04E5	408371
	630	GG07E4	407032	GG07E6	407033	GG07E5	408391
	800	GG08E4	407062	GG08E6	407063	GG08E5	408431
	1000	GG10E4	407092	GG10E6	407093	GG10E5	408441
	1250	GG13E4	407122	GG13E6	407123	GG13E5	408451
	1600	GG16E4	407152	GG16E6	407153	GG16E5	408491
	2000	GG20E4	407192	GG20E6	407193	GG20E5	408511
	2500	GG25E4	407232	GG25H6	407233	GG25H5	408526
	3200	GG32E4	407244	GG32H6	407245	GG32H5	408543
	4000 <sup>(1)</sup>	GG40H4	407280	GG40H6	407281	GG40H5	408563

(1) Rear vertical connection for indicated 4000A types

**Basic breakers executed in a fixed mounting pattern**

- With horizontal rear connection (for other options, please refer to page A.7)<sup>(1)</sup>
- With aux. contact block equipped with 3 NO and 3 NC contacts
- Basic breaker MUST be equipped with a trip unit (for options, please refer to page A.16 to A.21)
- For 1000V applications (M type under 5000A) phase separators are required (see page A.27)

**Fixed mounting pattern**

	Rating (A)	3 pole		4 pole Left Neutral		4 pole Right Neutral	
		Cat. No.	Ref. No.	Cat. No.	Ref. No.	Cat. No.	Ref. No.
 <p><b>M type</b> Icu = Ics = 100kA Icw = 85kA</p>	400	GG04M4	<b>407011</b>	GG04M6	<b>407012</b>	GG04M5	<b>408375</b>
	630	GG07M4	<b>407040</b>	GG07M6	<b>407041</b>	GG07M5	<b>408395</b>
	800	GG08M4	<b>407070</b>	GG08M6	<b>407071</b>	GG08M5	<b>408435</b>
	1000	GG10M4	<b>407100</b>	GG10M6	<b>407101</b>	GG10M5	<b>408445</b>
	1250	GG13M4	<b>407130</b>	GG13M6	<b>407131</b>	GG13M5	<b>408455</b>
	1600	GG16M4	<b>407160</b>	GG16M6	<b>407161</b>	GG16M5	<b>408495</b>
	2000	GG20M4	<b>407200</b>	GG20M6	<b>407201</b>	GG20M5	<b>408515</b>
	2500	GG25M4	<b>407236</b>	GG25M6	<b>407237</b>	GG25M5	<b>408528</b>
	3200	GG32M4	<b>407262</b>	GG32M6	<b>407263</b>	GG32M5	<b>408547</b>
	4000 <sup>(1)</sup>	GG40M4	<b>407288</b>	GG40M6	<b>407289</b>	GG40M5	<b>408567</b>
	 <p><b>G-M type</b> Icu = Ics = Icw 100kA</p>	3200	GG32G4	<b>407252</b>	GG32G6	<b>407253</b>	GG32G5
4000		GG40G4	<b>407270</b>	GG40G6	<b>407271</b>	GG40G5	<b>408561</b>
5000		GG50M4	<b>407306</b>	GG50M6	<b>407307</b>	GG50M5	<b>408583</b>
6400		GG64M4	<b>407326</b>	GG64M6	<b>407327</b>	GG64M5	<b>408587</b>
 <p><b>L type</b> Icu = Ics = 150kA Icw = 100kA</p>	3200	GG32L4	<b>407254</b>	GG32L6	<b>407255</b>	GG32L5	<b>408545</b>
	4000	GG40L4	<b>407284</b>	GG40L6	<b>407285</b>	GG40L5	<b>408565</b>
	5000	GG50L4	<b>407302</b>	GG50L6	<b>407303</b>	GG50L5	<b>408581</b>
	6400	GG64L4	<b>407322</b>	GG64L6	<b>407323</b>	GG64L5	<b>408585</b>







(1) Rear vertical connection for indicated 4000A types  
Trip unit field configurable at 0.50 or 100% of phase rating



## Isolators or non automatic breakers executed in a fixed mounting pattern

- With horizontal rear connection (for other options, please refer to page A.7)<sup>(1)</sup>
- With Aux. contact block equipped with 3 NO and 3 NC contacts
- For 1000V applications (M type under 5000A) phase separators are required (see page A.27)

### Fixed mounting pattern

	Rating (A)	3 pole			4 pole Left Neutral		4 pole Right Neutral	
		Cat. No.	Ref. No.	Cat. No.	Ref. No.	Cat. No.	Ref. No.	
 <p><b>R type</b> Non automatic Icw 42kA</p>	400	G704R4	444616	G704R6	444632	G704R5	444775	
	630	G707R4	444617	G707R6	444633	G707R5	444776	
	800	G708R4	444618	G708R6	444634	G708R5	444777	
	1000	G710R4	444619	G710R6	444635	G710R5	444778	
	1250	G713R4	444620	G713R6	444636	G713R5	444779	
	1600	G716R4	444621	G716R6	444637	G716R5	444780	
 <p><b>S type</b> Non automatic Icw 50kA</p>	400	GJ04S4	407380	GJ04S6	407381	GJ04S5	408612	
	630	GJ07S4	407400	GJ07S6	407401	GJ07S5	408616	
	800	GJ08S4	407420	GJ08S6	407421	GJ08S5	408620	
	1000	GJ10S4	407440	GJ10S6	407441	GJ10S5	408627	
	1250	GJ13S4	407460	GJ13S6	407461	GJ13S5	408635	
	1600	GJ16S4	407480	GJ16S6	407481	GJ16S5	408639	
	2000	GJ20S4	407500	GJ20S6	407501	GJ20S5	408643	
	2500	GJ25S4	410673	GJ25S6	410662			
 <p><b>N type</b> Non automatic Icw 65kA</p>	400	GW04N4	407376	GW04N6	407377	GW04N5	408613	
	630	GW07N4	407396	GW07N6	407397	GW07N5	408617	
	800	GW08N4	407416	GW08N6	407417	GW08N5	408621	
	1000	GW10N4	407436	GW10N6	407437	GW10N5	408628	
	1250	GW13N4	407456	GW13N6	407457	GW13N5	408636	
	1600	GW16N4	407476	GW16N6	407477	GW16N5	408640	
	2000	GW20N4	407496	GW20N6	407497	GW20N5	408644	
	2500	GJ25N4	407520	GJ25N6	407521	GJ25N5	408683	
	3200	GJ32N4	407539	GJ32N6	407540	GJ32N5	408689	
	4000 <sup>(1)</sup>	GJ40N4	407560	GJ40N6	407561	GJ40N5	408695	
 <p><b>F type</b> Icw = 65kA</p>	2500	GW25F4	410661	GW25F6	410663	GW25F5	410690	
 <p><b>M type</b> Non automatic Icw 85kA</p>	400	GW04M4	408350	GW04M6	408351	GW04M5	408712	
	630	GW07M4	408352	GW07M6	408353	GW07M5	408651	
	800	GW08M4	408354	GW08M6	408355	GW08M5	408655	
	1000	GW10M4	408356	GW10M6	408357	GW10M5	408659	
	1250	GW13M4	408358	GW13M6	408359	GW13M5	408668	
	1600	GW16M4	408360	GW16M6	408361	GW16M5	408672	
	2000	GW20M4	408362	GW20M6	408363	GW20M5	408676	
	2500	GW25M4	408364	GW25M6	408365	GW25M5	408685	
	3200	GW32M4	408366	GW32M6	408367	GW32M5	408691	
4000 <sup>(1)</sup>	GW40M4	408368	GW40M6	408369	GW40M5	408697		
 <p><b>L type</b> Non automatic Icw 100kA</p>	3200	GJ32L4	407535	GJ32L6	407536	GJ32L5	408721	
	4000	GJ40L4	407556	GJ40L6	407557	GJ40L5	408723	
	5000	GJ50L4	407567	GJ50L6	407568	GJ50L5	408725	
	6400	GJ64L4	407577	GJ64L6	407578	GJ64L5	408727	

(1) Rear vertical connection for indicated 4000A types

## Termination sets for breakers and isolators in fixed pattern

- To modify standard connection (horizontal rear) to:
- Vertical rear
- Front flat connection
- Sets containing terminals and hardware for the line and load side of the breaker

### Termination sets for Breakers and Isolators in fixed pattern

Vertical rear connections		3 pole <sup>(1)</sup>		4 pole <sup>(1)</sup>	
Rating (A)	Suited for use with EntelliGuard G types	Cat. No.	Ref. No.	Cat. No.	Ref. No.
<b>Terminations for frame T</b>					
400 - 1600A	GT type R & K and G7 type R	GT16H4RVI	444626	GT16H6RVI	444628
<b>Terminations for frame 1</b>					
400 - 1600A	GG, GJ & GW type S, N & H	G16H4RVI	408058	G16H6RVI	408082
2000A	GG, GJ & GW type S, N & H	G20H4RVI	408059	G20H6RVI	408083
2500A	GG, GW type F	will be dispatched as factory assembled			
<b>Terminations for frame 2</b>					
400 - 3200A <sup>(2)</sup>	GG, GJ & GW type E, N, H & M	G32M4RVI	408070	G32M6RVI	408071
4000A <sup>(3)</sup>	GG, GJ & GW type N, H & M	G40M4RVI	408072	G40M6RVI	408074
<b>Terminations for frame 3</b>					
3200 - 6400A	GG & GJ type G, M & L	G64L4RVI	408073	G64L6RVI	408075
<b>Front access connections</b>					
<b>Terminations for frame T</b>					
400 - 1600A	GT type R & K and G7 type R	GT16H4FFI	444625	GT16H6FFI	444627
<b>Terminations for frame 1</b>					
400 - 1600A	GG, GJ & GW type S, N & H	G16H4FFI	408060	G16H6FFI	408062
2000A	GG, GJ & GW type S, N & H	G20H4FFI	408061	G20H6FFI	408063
2500A	GG, GJ & GW type S, N & H	will be dispatched as factory assembled			
<b>Terminations for frame 2</b>					
400 - 3200A	GG, GJ & GW type E, N, H & M	G32M4FFI	408066	G32M6FFI	408068
4000A	GG, GJ & GW type N, H & M	G40M4FFI	408067	G40M6FFI	408069
<b>Wall mounting brackets<sup>(4)</sup></b>					
Wall mounting brackets for frame T, 1 & 2		GFMTG	408085	GFMTG	408085

(1) Sets are made up of 6pcs for 3pole and 8pcs for 4 pole.  
 (2) For 400-2500A an alternative type is available in a set of 3 Cat. G25M3RVI Ref. 408076  
 (3) Normally supplied with the standard 4000A breaker  
 (4) Recommended for use with front access connections.



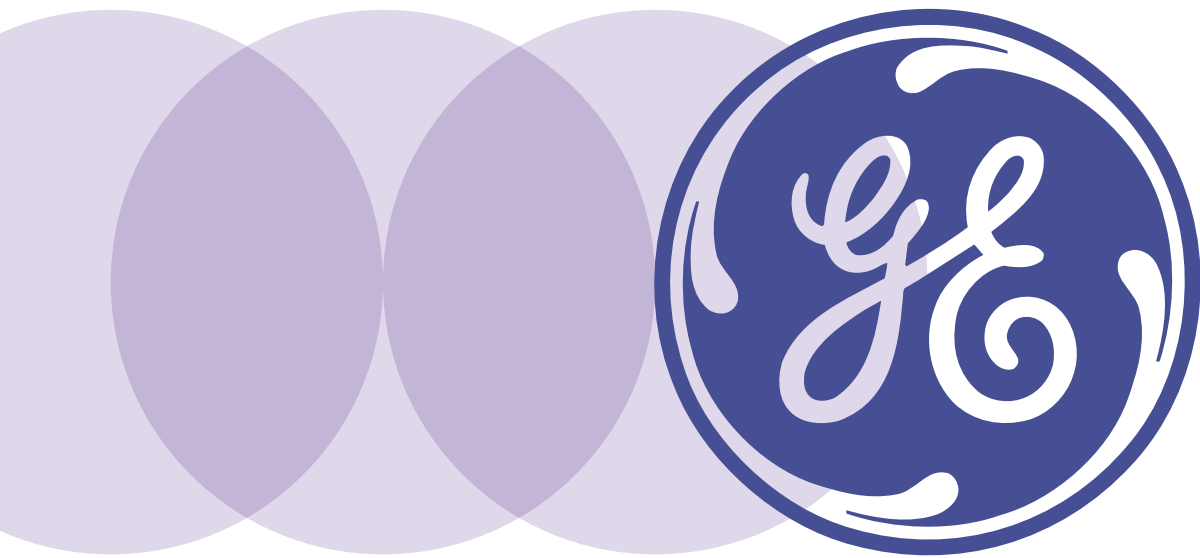





**Basic breakers in a draw-out pattern**

- With aux. contact block equipped with 3 NO and 3 NC contacts
- Basic breaker MUST be equipped with a trip unit (please refer to page A.16 to A.21 for options)
- A cassette is needed, please refer to page A.14 for options
- For 1000V applications (M type under 5000A) phase separators are required (see page A.27)

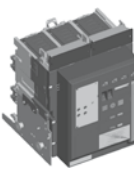
**Draw-out pattern; moving portion only**

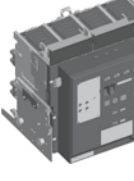
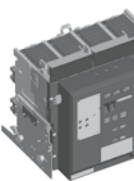
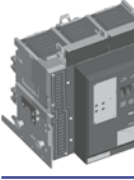
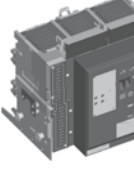

	Rating (A)	3 pole		4 pole Left Neutral		4 pole Right Neutral	
		Cat. No.	Ref. No.	Cat. No.	Ref. No.	Cat. No.	Ref. No.
 <p><b>R type</b> Icu = Ics = 50kA Icw = 42kA</p>	400	GT04R1	444500	GT04R3	444520	GT04R2	444720
	630	GT07R1	444501	GT07R3	444521	GT07R2	444721
	800	GT08R1	444502	GT08R3	444522	GT08R2	444722
	1000	GT10R1	444503	GT10R3	444523	GT10R2	444723
	1250	GT13R1	444504	GT13R3	444524	GT13R2	444724
	1600	GT16R1	444505	GT16R3	444525	GT16R2	444725
 <p><b>S type</b> Icu = Ics = Icw 50kA</p>	400	GG04S1	407017	GG04S3	407018	GG04S2	408378
	630	GG07S1	407046	GG07S3	407047	GG07S2	408398
	800	GG08S1	407076	GG08S3	407077	GG08S2	408438
	1000	GG10S1	407106	GG10S3	407107	GG10S2	408448
	1250	GG13S1	407136	GG13S3	407137	GG13S2	408458
	1600	GG16S1	407166	GG16S3	407167	GG16S2	408498
	2000	GG20S1	407206	GG20S3	407207	GG20S2	408518
	2500	GG25S1	410664	GG25S3	410666	GG25S2	410665
 <p><b>K type</b> Icu = 65kA Ics = Icw = 50kA</p>	400	GT04K1	444506	GT04K3	444526	GT04K2	444726
	630	GT07K1	444507	GT07K3	444527	GT07K2	444727
	800	GT08K1	444508	GT08K3	444528	GT08K2	444728
	1000	GT10K1	444509	GT10K3	444529	GT10K2	444729
	1250	GT13K1	444510	GT13K3	444530	GT13K2	444730
	1600	GT16K1	444511	GT16K3	444531	GT16K2	444731
 <p><b>N type</b> Icu = Ics = Icw 65kA</p>	400	GG04N1	407013	GG04N3	407014	GG04N2	408376
	630	GG07N1	407042	GG07N3	407043	GG07N2	408396
	800	GG08N1	407072	GG08N3	407073	GG08N2	408436
	1000	GG10N1	407102	GG10N3	407103	GG10N2	408446
	1250	GG13N1	407132	GG13N3	407133	GG13N2	408456
	1600	GG16N1	407162	GG16N3	407163	GG16N2	408496
	2000	GG20N1	407202	GG20N3	407203	GG20N2	408516
	2500	GG25N1	407238	GG25N3	407239	GG25N2	408529
	3200	GG32N1	407264	GG32N3	407265	GG32N2	408548
	4000	GG40N1	407290	GG40N3	407291	GG40N2	408568
 <p><b>F type</b> Icu = Ics = 85kA Icw = 65kA</p>	2500	GG25F1	410667	GG25F3	410669	GG25F2	410668
 <p><b>H type</b> Icu = Ics = 85kA Icw = 65kA</p>	400	GG04H1	407005	GG04H3	407006	GG04H2	408372
	630	GG07H1	407034	GG07H3	407035	GG07H2	408392
	800	GG08H1	407064	GG08H3	407065	GG08H2	408432
	1000	GG10H1	407094	GG10H3	407095	GG10H2	408442
	1250	GG13H1	407124	GG13H3	407125	GG13H2	408452
	1600	GG16H1	407154	GG16H3	407155	GG16H2	408492
	2000	GG20H1	407194	GG20H3	407195	GG20H2	408512
 <p><b>E-H type</b> Icu = Ics = Icw 85kA</p>	400	GG04E1	407001	GG04E3	407002	GG04E2	408370
	630	GG07E1	407030	GG07E3	407031	GG07E2	408390
	800	GG08E1	407060	GG08E3	407061	GG08E2	408430
	1000	GG10E1	407090	GG10E3	407091	GG10E2	408440
	1250	GG13E1	407120	GG13E3	407121	GG13E2	408450
	1600	GG16E1	407150	GG16E3	407151	GG16E2	408490
	2000	GG20E1	407190	GG20E3	407191	GG20E2	408510
	2500	GG25H1	407230	GG25H3	407231	GG25H2	-
	3200	GG32H1	407242	GG32H3	407273	GG32H2	-
	4000	GG40H1	407278	GG40H3	407279	GG40H2	-



## Basic breakers in a draw-out pattern

- With aux. contact block equipped with 3 NO and 3 NC contacts
- Basic breaker MUST be equipped with a trip unit (please refer to page A.16 to A.21 for options)
- A cassette is needed, please refer to page A.14 for options
- For 1000V applications (M type under 5000A) phase separators are required (see page A.27)

### Draw-out pattern; moving portion only

	Rating (A)	3 pole		4 pole left neutral		4 pole right neutral	
		Cat. No.	Ref. No.	Cat. No.	Ref. No.	Cat. No.	Ref. No.
 <p><b>M type</b> Icu = Ics = 100kA Icw = 85kA</p>	400	GG04M1	407009	GG04M3	407010	GG04M2	408374
	630	GG07M1	407038	GG07M3	407039	GG07M2	408394
	800	GG08M1	407068	GG08M3	407069	GG08M2	408434
	1000	GG10M1	407098	GG10M3	407099	GG10M2	408444
	1250	GG13M1	407128	GG13M3	407129	GG13M2	408454
	1600	GG16M1	407158	GG16M3	407159	GG16M2	408494
	2000	GG20M1	407198	GG20M3	407199	GG20M2	408514
	2500	GG25M1	407234	GG25M3	407235	GG25M2	408527
	3200	GG32M1	407260	GG32M3	407261	GG32M2	408546
	4000	GG40M1	407286	GG40M3	407287	GG40M2	408566
	 <p><b>G-M type</b> Icu = Ics = Icw 100kA</p>	3200	GG32G1	407250	GG32G3	407251	GG32G2
4000		GG40G1	407268	GG40G3	407269	GG40G2	408560
5000		GG50M1	407304	GG50M3	407305	GG50M2	408582
6400		GG64M1	407324	GG64M3	407325	GG64M2	408586
 <p><b>L type</b> Icu = Ics = 150kA Icw = 100kA</p>	3200	GG32L1	407248	GG32L3	407249	GG32L2	408544
	4000	GG40L1	407282	GG40L3	407283	GG40L2	408564
	5000	GG50L1	407300	GG50L3	407301	GG50L2	408580
	6400	GG64L1	407320	GG64L3	407321	GG64L2	408584

Trip unit field configurable at 0.50 or 100% of phase rating

**Draw-out breakers: "limited derating types"**

- Draw-out breaker with no or very limited derating when used enclosed
- With aux. contact block equipped with 3 NO and 3 NC contacts
- Basic breaker MUST be equipped with a trip unit (please refer to page A.16 to A.21 for options)
- A cassette with vertical clusters is needed, please refer to page A.14 for options

**Draw-out breakers pattern: moving portion only**



Rating (A)	3 pole		4 pole left neutral	
	Cat. No.	Ref. No.	Cat. No.	Ref. No.
3200	GH32N1	407350	GH32N3	407351
4000	GH40N1	407356	GH40N3	407357
3200	GH32H1	407346	GH32H3	407347
4000	GH40H1	407352	GH40H3	407353
3200	GH32M1	407348	GH32M3	407349
4000	GH40M1	407354	GH40M3	407355

**N type**  
Icu = Ics = Icw  
65kA

**H type**  
Icu = Ics = Icw  
85kA

**M type**  
Icu = Ics = 100kA  
Icw = 85kA

Frame 2 only

Draw-out pattern; moving portion

Intro

A

B

C

D

E

F





X



## Isolators or non automatic breakers in a draw-out pattern

- With aux. contact block equipped with 3 NO and 3 NC contacts
- A cassette is needed, please refer to page A.14 for options
- For 1000V applications (M type under 5000A) phase separators are required (see page A.25)

### Draw-out pattern; moving portion only

Order codes	Image	Type	Rating (A)	3 pole		4 pole left neutral		4 pole right neutral	
				Cat. No.	Ref. No.	Cat. No.	Ref. No.	Cat. No.	Ref. No.
A		R type Non automatic lcv 42kA	400	G704R1	444585	G704R3	444600	G704R2	444760
			630	G707R1	444586	G707R3	444601	G707R2	444761
			800	G708R1	444587	G708R3	444602	G708R2	444762
			1000	G710R1	444588	G710R3	444603	G710R2	444763
			1250	G713R1	444589	G713R3	444604	G713R2	444764
			1600	G716R1	444590	G716R3	444605	G716R2	444765
B		S type Non automatic lcv 50kA	400	GJ04S1	407378	GJ04S3	407379	GJ04S2	408610
			630	GJ07S1	407398	GJ07S3	407399	GJ07S2	408614
			800	GJ08S1	407418	GJ08S3	407419	GJ08S2	408618
			1000	GJ10S1	407438	GJ10S3	407439	GJ10S2	408625
			1250	GJ13S1	407458	GJ13S3	407459	GJ13S2	408629
			1600	GJ16S1	407478	GJ16S3	407479	GJ16S2	408637
			2000	GJ20S1	407498	GJ20S3	407499	GJ20S2	408641
			2500	GJ25S1	410674	GJ25S3	410672		
C		N type Non automatic lcv 65kA	400	GW04N1	407374	GW04N3	407375	GW04N2	408611
			630	GW07N1	407394	GW07N3	407395	GW07N2	408615
			800	GW08N1	407414	GW08N3	407415	GW08N2	408619
			1000	GW10N1	407434	GW10N3	407435	GW10N2	408626
			1250	GW13N1	407454	GW13N3	407455	GW13N2	408630
			1600	GW16N1	407474	GW16N3	407475	GW16N2	408638
			2000	GW20N1	407494	GW20N3	407495	GW20N2	408642
			2500	GW25F1	410670	GW25F3	410671		
			2500	GJ25N1	407518	GJ25N3	407519	GJ25N2	408680
			3200	GJ32N1	407537	GJ32N3	407538	GJ32N2	408686
D		F type Non automatic lcv 65kA	2500	GW25F1	410670	GW25F3	410671	GW25F2	410689
E		M type Non automatic lcv 85kA	400	GW04M1	408400	GW04M3	408401	GW04M2	408710
			630	GW07M1	408402	GW07M3	408403	GW07M2	408714
			800	GW08M1	408404	GW08M3	408405	GW08M2	408653
			1000	GW10M1	408406	GW10M3	408407	GW10M2	408657
			1250	GW13M1	408408	GW13M3	408409	GW13M2	408666
			1600	GW16M1	408410	GW16M3	408411	GW16M2	408670
			2000	GW20M1	408412	GW20M3	408413	GW20M2	408674
			2500	GW25M1	408414	GW25M3	408415	GW25M2	408682
F		L type Non automatic lcv 100kA	3200	GJ32L1	407533	GJ32L3	407534	GJ32L2	408720
			4000	GJ40L1	407554	GJ40L3	407555	GJ40L2	408722
X			5000	GJ50L1	407565	GJ50L3	407566	GJ50L2	408724
			6400	GJ64L1	407575	GJ64L3	407576	GJ64L2	408726



**Isolators or non automatic breakers in a draw-out pattern:  
"limited derating types"**

- Draw-out patterns with no or very limited derating when used enclosed
- With aux. contact block equipped with 3 NO and 3 NC contacts
- A cassette with vertical clusters is needed, please refer to page A.14 for options

**Draw-out pattern, vertical clusters; moving portion only**



	Rating (A)	3 pole		4 pole	
		Cat. No.	Ref. No.	Cat. No.	Ref. No.
<b>N type</b> Non automatic Icw 65kA	3200	3 pole		4 pole left neutral	
		GK32N1	407591	GK32N3	407592
	4000	GK40N1	407595	GK40N3	407596
		<b>H type</b> Non automatic Icw 85kA			
3200	GZ32H1	407589	GZ32H3	407590	
	4000	GZ40H1	407593	GZ40H3	407594

Draw-out pattern; moving portion

Intro

A

B

C

D

E

F

X



## Cassettes for use with breakers and Isolators in draw-out pattern - Factory mounted

- References apply for cassettes supplied in one packaging with breakers or isolators (for separate cassettes see page A.27)
- With connection modes as indicated in left column
- Each cassette is supplied with safety shutters

### Cassettes for draw-out pattern; fixed portion only

Universal rear connections		3 pole		4 pole	
Rating (A)	Suited for use with EntelliGuard G types	Cat. No.	Ref. No.	Cat. No.	Ref. No.
<i>Cassette for frame T</i>					
400 - 1600A	GT type R & K and G7 type R	GT16K2UXXXXM	444691	GT16K5UXXXXM	444694
<i>Cassette for frame 1</i>					
400 - 1600A	GG & GJ type S	GG16S2UXXXXM	407616	GG16S5UXXXXM	407618
1600A	GG, GJ & GW type N & H	GG16H2UXXXXM	408202	GG16H5UXXXXM	408205
2000A	GG, GJ & GW type S, N & H	GG20H2UXXXXM	408212	GG20H5UXXXXM	408215
2500A <sup>(1)</sup>	GG, GJ & GW type S & F	GG25H2UXXXXM	410677	GG25H5UXXXXM	410678
<i>Cassette for frame 2</i>					
400 - 2000A	GG, GJ & GW type N, E & M	GG20M2UXXXXM	408224	GG20M5UXXXXM	408227
2500A	GG, GJ & GW type N, H & M	GG25M2UXXXXM	408236	GG25M5UXXXXM	408239
3200A <sup>(2)</sup>	GG, GJ & GW type N, H & M	GG32M2UXXXXM	408247	GG32M5UXXXXM	408251
4000A <sup>(2)</sup>	GG, GJ & GW type N, H & M	GG40M2UXXXXM	408259	GG40M5UXXXXM	408263
<i>Remark: each cassette is supplied with connection pads that can be rotated and used for vertical or horizontal connections.</i>					
<i>Cassette for frame 3<sup>(3)</sup></i>					
3200 - 6400A <sup>(4)</sup>	GG & GJ type G, M & L	GG64L2UXXXXM	408281	GG64L5UXXXXM	408283
<i>Horizontal rear connections</i>					
<i>Cassette for frame T</i>					
400 - 1600A	GT type R & K and G7 type R	GT16K2HXXXXM	444692	GT16K5HXXXXM	444695
<i>Vertical rear connections</i>					
<i>Connection pad for limited derating frame 1</i>					
2500A	GG, GJ & GW type S & F	GG25F2VXXXXM	410675	GG25F5VXXXXM	407676
<i>Cassette with dual vertical clusters and connection pads for limited derating frame 2</i>					
3200A	GH, GK, GJ & GZ type N, H & M	GH32M2VXXXXM	408292	GH32M5VXXXXM	408293
4000A <sup>(2)</sup>	GH, GK, GJ & GZ type N, H & M	GH40M2VXXXXM	408294	GH40M5VXXXXM	408295
<i>Rear terminals</i>					
<i>To be ordered along with cassettes with NO rear terminals</i>					
1600A	Adapter connection frame 1 - 3P/4P - S	G16H1UNIR <sup>(5)</sup>	410699		
400A-2000A	Adapter connection frame 2 - 3P/4P - E, N, H & M	G32M1UNIR <sup>(5)</sup>	410701		
2500A	Adapter connection frame 2 - 3P/4P - N, H & M	G32M1UNIR <sup>(5)</sup>	410701		
3200A	Adapter connection frame 2 - 3P/4P - N, H & M	G32M1UNIR <sup>(5)</sup>	410701		
4000A	Adapter connection frame 2 - 3P/4P - N, H & M	G40M1RVIR <sup>(5)(6)</sup>	410702		
3200-6400A	Adapter connection frame 3 - 3P/4P - G, M & L	G64L1UNIR <sup>(5)</sup>	410704		
400A-1600A	Adapter connection frame T - 3P - G, M & L	GT16H3UNIR <sup>(7)</sup>	410705		
400A-1600A	Adapter connection frame T - 4P - G, M & L	GT16H7UNIR <sup>(7)</sup>	410706		

(1) Cassettes for frame 1 are limited to a current of 2000A when connected in vertical mode. Connected in vertical mode a 2500A rating is achieved  
 (2) Cassettes for frame 2 are limited to a current of 3200A when connected in horizontal mode. Connected in vertical mode a 4000A rating is achieved  
 (3) The cassette for frame 3 is limited to a current of 5000A when connected in horizontal mode.  
 Connected in vertical mode it has a rating of 6400A. This cassette type is NOT depicted here  
 (4) 4th pole on left  
 (5) For 3 pole order 3 sets, for 4 pole order 4 sets  
 (6) Only connected in vertical mode, 4000A rating is achieved  
 (7) For 3 pole/4 pole order 1 set



**Cassettes for draw-out pattern; fixed portion only**

Front access connections		3 pole		4 pole	
Rating (A)	Suited for use with EntelliGuard G types	Cat. No.	Ref. No.	Cat. No.	Ref. No.
<i>Cassette for frame T</i>					
400 - 1600A	GT type R & K and G7 type R	GT16K2FXXXXM	444690	GT16K5FXXXXM	444693
<i>Cassette for frame 1</i>					
400 - 1600A	GG & GJ type S	GG16S2FXXXXM	407626	GG16S5FXXXXM	407628
1600A	Type N: GG & GW; Type H: GG	GG16H2FXXXXM	408200	GG16H5FXXXXM	408203
2000A	Type S: GG & GJ; Type N: GG & GW; Type H: GG	GG20H2FXXXXM	408210	GG20H5FXXXXM	408213
2500A	GG, GJ & GW type S & F	GG25H2FXXXXM	410679	GG25H5FXXXXM	410680
<i>Cassette for frame 2</i>					
400 - 2000A	GG, GJ & GW type E, N, H & M	GG20M2FXXXXM	408222	GG20M5FXXXXM	408225
2500A	GG, GJ & GW type N, H & M	GG25M2FXXXXM	408234	GG25M5FXXXXM	408237
3200A	GG, GJ & GW type N, H & M	GG32M2FXXXXM	408245	GG32M5FXXXXM	408249
4000A	GG, GJ & GW type N, H & M	GG40M2FXXXXM	408257	GG40M5FXXXXM	408261
<i>No rear copper terminals</i>					
<i>Cassette for frame T</i>					
400 - 1600A	GT type R & K and G7 typ R	GT16K2XXXXXM	444512	GT16K5XXXXXM	444514
<i>Cassette for frame 1</i>					
400 - 1600A	GG & GJ type S	GG16S2XXXXXM	410627	GG16S5XXXXXM	410629
1600A	GG & GJ type H	GG16H2XXXXXM	410623	GG16H5XXXXXM	410625
2000A	Type S: GG & GJ; Type N: GG & GW; Type H: GG	GG20H2XXXXXM	410631	GG20H5XXXXXM	410633
<i>Cassette for frame 2</i>					
400 - 2000A	GG, GJ & GW type E, N, H & M	GG20M2XXXXXM	410635	GG20M5XXXXXM	410637
2500A	GG, GJ & GW type N, H & M	GG25M2XXXXXM	410639	GG25M5XXXXXM	410641
3200A	GG, GJ & GW type N, H & M	GG32M2XXXXXM	410643	GG32M5XXXXXM	410645
4000A	GG, GJ & GW type N, H & M	GG40M2XXXXXM	410647	GG40M5XXXXXM	410648
<i>Cassette for frame 3<sup>(1)</sup></i>					
3200 - 6400A <sup>(1)</sup>	GG & GW type G, M & L	GG64L2XXXXXM	410651	GG64L5XXXXXM	410653

(1) The cassette for frame 3 is limited to a current of 5000A when connected in horizontal mode. Connected in vertical mode it has a rating of 6400A. This cassette type is NOT depicted here

Intro

A

B

C

D







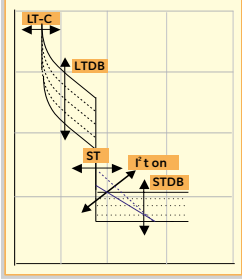

E

F

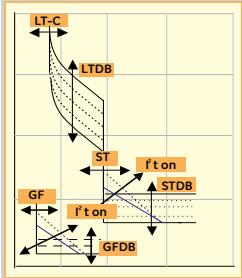
X

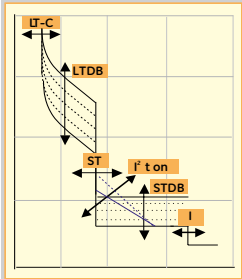

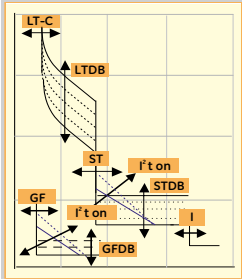
## Trip units - Factory mounted

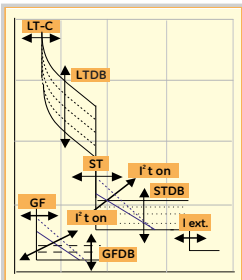
	GT-E Basic functionality	Designation	Extended functionality	Cat. No.	Ref. No.
		<b>GT-E trip unit with:</b>	None	GTG00K1XXSFXXXX	408800
		LT-C 0.2-1 x In = Ir LTDB ST I <sup>2</sup> T ON or OFF STDB			
		<b>GT-rating plug</b>	Required for all types	GTPUNI	408860
		<b>GT-E trip unit with:</b>	None	GTG00K2XXSFXXXX	408801
		LT-C 0.2 -1 x In = Ir LTDB ST I <sup>2</sup> T ON or OFF STDB GF I <sup>2</sup> T ON or OFF GFDB			
		<b>GT-rating plug</b>	Required for all types	GTPUNI	408860
		<b>GT-S trip unit with:</b>	None	GTG00K9XXSFXXXX	408803
		LT-C 0.2 -1 x In = Ir LTDB ST I <sup>2</sup> T ON or OFF STDB I			
		<b>GT-rating plug</b>	Required for all types	GTPUNI	408860
		<b>GT-S trip unit with:</b>	None	GTG00K3XXSFXXXX	408805
		LT-C 0.2 -1 x In = Ir LTDB ST I <sup>2</sup> T ON or OFF STDB GF I <sup>2</sup> T ON or OFF GFDB	+ Modbus communication	GTG00K3X2SFXXXX	408807
		<b>GT-rating plug</b>	Required for all types	GTPUNI	408860
		<b>GT-S trip unit with:</b>	None	GTG00K4XXSFXXXX	408806
		LT-C 0.2 -1 x In = Ir LTDB ST I <sup>2</sup> T ON or OFF STDB GF I <sup>2</sup> T ON or OFF GFDB I ext.	+ Modbus communication	GTG00K4X2SFXXXX	408808
		<b>GT-rating plug</b>	Required for all types	GTPUNI	408860

A special version of trip unit with magnetic only. Version available with ordering code GTG00K5XXSFXXXX. For details, please contact nearest sales office

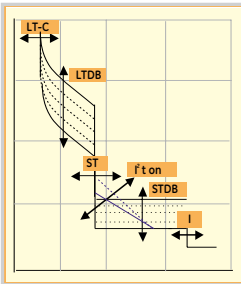
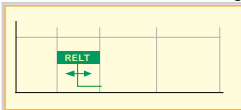
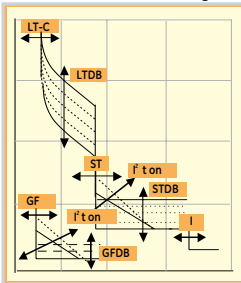
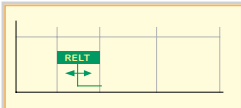
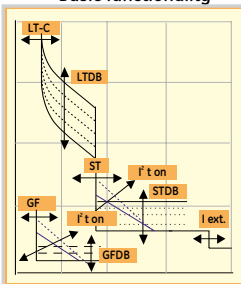
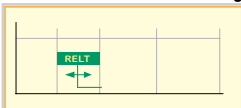

Trip Units - Factory mounted

GT- N	Basic functionality	Designation	Extended functionality	Cat. No.	Ref. No.
		<b>GT-N Trip Unit with:</b> LT-C 0.2 -1 x In = Ir LTDB ST I <sup>2</sup> T ON or OFF STDB I RELT	Measurement unit <sup>(1)</sup> RELT instantaneous	GTG00K9X4SFXXXX	408813
	Extended functionality 	<b>GT-rating plug</b>	Required for all types	GTPUNI	408860
	Basic functionality 	<b>GT-N Trip Unit with:</b> LT-C 0.2 -1 x In = Ir LTDB ST I <sup>2</sup> T ON or OFF GF I <sup>2</sup> T ON or OFF GFDB I RELT	Measurement unit <sup>(1)</sup> RELT instantaneous + Modbus communication + zone selective interlock on I, ST & GF functions	GTG00K3X4SFXXXX	408815
	Extended functionality 	<b>GT-rating plug</b>	Required for all types	GTPUNI	408860
	Basic functionality 	<b>GT-N Trip Unit with:</b> LT-C 0.2 -1 x In = Ir LTDB ST I <sup>2</sup> T ON or OFF STDB GF I <sup>2</sup> T ON or OFF GFDB I ext. RELT	Measurement unit <sup>(1)</sup> RELT instantaneous + Modbus communication + zone selective interlock on I, ST & GF functions	GTG00K4X4SFXXXX	408816
	Extended functionality 	<b>GT-rating plug</b>	Required for all types	GTPUNI	408860

(1) An auxiliary power conditioner is obligatory when a fully functioning measurement is required see page A.26  
 A special version of trip unit with magnetic only. Version available with ordering code GTG00KSX4SFXXXX. For details, please contact nearest sales office



## Trip units - Factory mounted

Order codes



**Remark:**  
The GT-H type offers five overload (LT) band choices:

- 1) **LTC** (Bimetal equivalent shape)
- 2) **LTF** (Fuse equivalent shape)
- 3) **I** (Inverse shape)
- 4) **VI** (Very inverse shape)
- 5) **XI** (Extremely inverse shape)

**GT-H Basic functionality**

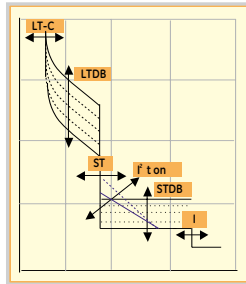

**Extended functionality**

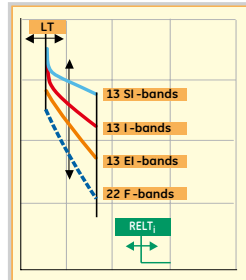

**Basic functionality**

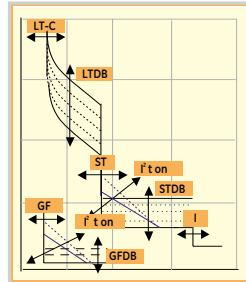

**Extended functionality**

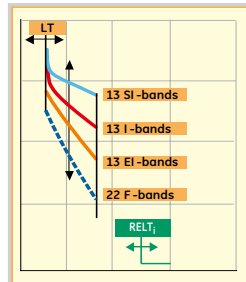

Designation	Extended functionality	Cat. No.	Ref. No.
<b>GT-H trip unit with:</b> LT 0,2 - 1 x In =Ir Curve shapes: LT-C, LT-F, LT-I, LT-EI & LT-XI LTDB ST I <sup>2</sup> T ON (3 bands) or OFF STDB I RELT LT, ST and I functions can be switched ON or OFF	A choice of FIVE LT band shapes Measurement unit <sup>(1)</sup> Relay functionality RELT instantaneous	GTG00N9X5SFXXXX	408823
	A choice of FIVE LT band shapes Measurement unit <sup>(1)</sup> Data acquisition & Relay functionality RELT instantaneous Modbus communication Relay functionality & Wave form cap.	GTG00N9X8SFXXXX	408863
	A choice of FIVE LT band shapes Measurement unit <sup>(1)</sup> Relay functionality RELT instantaneous Profibus communication	GTG00N9X9SFXXXX	408865
<b>GT-rating plug</b>	Required for all types	GTPUNI	408860
<b>GT-H trip unit with:</b> LT 0,2 - 1 x In =Ir Curve shapes: LT-C, LT-F, LT-I, LT-EI & LT-XI LTDB ST I <sup>2</sup> T ON (3 bands) or OFF STDB GF sum I <sup>2</sup> T ON (3 bands) or OFF GF CT I <sup>2</sup> T ON (3 bands) or OFF GFDB (on CT & Sum) I RELT LT, ST, I and GF functions can be switched ON or OFF	A choice of FIVE LT band shapes Dual GF protection (Res/Sum or CT) Measurement unit <sup>(1)</sup> Relay functionality RELT instantaneous	GTG00N5X5SFXXXX	408825
	A choice of FIVE LT band shapes Dual GF protection (Res/Sum or CT) Measurement unit <sup>(1)</sup> Relay functionality & Wave form cap. RELT instantaneous Modbus communication	GTG00N5X8SFXXXX	408833
	A choice of FIVE LT band shapes Dual GF protection (Res/Sum or CT) Profibus communication	GTG00N5X9SFXXXX	408841
	A choice of FIVE LT band shapes Dual GF protection (Res/Sum or CT) Zone selective interlock on ST, I & GF Measurement unit <sup>(1)</sup> Relay functionality RELT instantaneous	GTG00N5T5SFXXXX	408829
	A choice of FIVE LT band shapes Dual GF protection (Res/Sum or CT) Zone selective interlock on ST, I & GF Measurement unit <sup>(1)</sup> Relay functionality & Wave form cap. RELT instantaneous Modbus communication	GTG00N5T8SFXXXX	408837
	A choice of FIVE LT band shapes Dual GF protection (Res/Sum or CT) Zone selective interlock on ST, I & GF Measurement unit <sup>(1)</sup> Relay functionality RELT instantaneous Profibus communication	GTG00N5T9SFXXXX	408845
<b>GT-rating plug</b>	Required for all types	GTPUNI	408860

(1) An auxiliary power conditioner is obligatory when a fully functioning measurement is required see page A.26  
A special version of trip unit with magnetic only. Version available with ordering code GTG00KSXXSFXXXX. For details, please contact nearest sales office





## Trip units - Factory mounted



**Remark:**  
The GT-H type offers five overload (LT) band choices:

- 1) **LTC** (Bimetal equivalent shape)
- 2) **LTF** (Fuse equivalent shape)
- 3) **I** (Inverse shape)
- 4) **VI** (Very inverse shape)
- 5) **XI** (Extremely inverse shape)

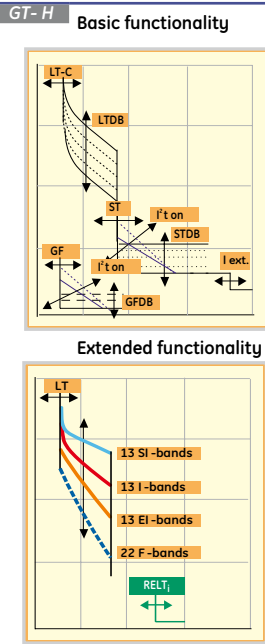

Designation	Extended functionality	Cat. No.	Ref. No.
<b>GT-H trip unit with:</b>	A choice of FIVE LT band shapes	GTG00N6X5SFXXXX	<b>408826</b>
LT 0.2 - 1 x In =Ir	GFsum(+A) and GFct (+A) protection		
Curve shapes: LT-C, LT-F, LT-I, LT-EI & LT-XI	Measurement unit <sup>(1)</sup>		
	Relay functionality		
LTDB	RELT instantaneous		
ST I <sup>2</sup> T ON (3 bands) or OFF	With standard instantaneous		
STDB	<i>Idem with extended instantaneous</i>	GTG00N8X5SFXXXX	<b>408828</b>
GF sum I <sup>2</sup> T ON (3 bands) or OFF	A choice of FIVE LT band shapes	GTG00N6X8SFXXXX	<b>408834</b>
With alarm function <sup>(2)</sup>	GFsum(+A) and GFct (+A) protection		
GF CT I <sup>2</sup> T ON (3 bands) or OFF	Measurement unit <sup>(1)</sup>		
With alarm function <sup>(2)</sup>	Relay functionality & Wave form cap.		
GFDB (on CT & Sum)	RELT instantaneous		
I <sub>1</sub> or I <sub>ext.</sub>	Modbus communication		
RELT	With standard instantaneous		
LT, ST, I, Gfsum, GFct and the alarm functions can be switched ON or OFF	<i>Idem with extended instantaneous</i>	GTG00N8X8SFXXXX	<b>408836</b>
	A choice of FIVE LT band shapes	GTG00N6X9SFXXXX	<b>408842</b>
	GFsum(+A) and GFct (+A) protection		
	Measurement unit <sup>(1)</sup>		
	Relay functionality		
	RELT instantaneous		
	Profibus communication		
	With standard instantaneous		
	<i>Idem with extended instantaneous</i>	GTG00N8X9SFXXXX	<b>408844</b>
	A choice of FIVE LT band shapes	GTG00N6T5SFXXXX	<b>408830</b>
	GFsum(+A) and GFct (+A) protection		
	Zone selective interlock on ST, I & GF		
	Measurement unit <sup>(1)</sup>		
	Relay functionality		
	RELT instantaneous		
	With standard instantaneous		
	<i>Idem with extended instantaneous</i>	GTG00N8T5SFXXXX	<b>408832</b>
	A choice of FIVE LT band shapes	GTG00N6T8SFXXXX	<b>408838</b>
	GFsum(+A) and GFct (+A) protection		
	Zone selective interlock on ST, I & GF		
	Measurement unit <sup>(1)</sup>		
	Relay functionality & Wave form cap.		
	RELT instantaneous		
	Modbus communication		
	With standard instantaneous		
	<i>Idem with extended instantaneous</i>	GTG00N8T8SFXXXX	<b>408840</b>
	A choice of FIVE LT band shapes	GTG00N6T9SFXXXX	<b>408846</b>
	GFsum(+A) and GFct (+A) protection		
	Zone selective interlock on ST, I & GF		
	Measurement unit <sup>(1)</sup>		
	Relay functionality		
	RELT instantaneous		
	Profibus communication		
	With standard instantaneous		
	<i>Idem with extended instantaneous</i>	GTG00N8T9SFXXXX	<b>408848</b>
<b>GT-rating plug</b>	Required for all types	GTPUNI	<b>408860</b>

(1) An auxiliary power conditioner is obligatory when a fully functioning measurement is required see page A.26

(2) Closes a contact for use as an alarm signal

A special version of trip unit with magnetic only. Version available with ordering code GTG00KSXXSFXXXX. For details, please contact nearest sales office

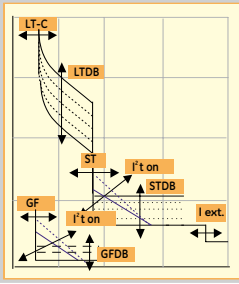
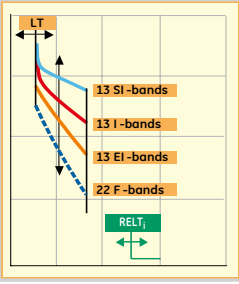

Trip Units - Factory mounted

GT-HE Basic functionality		Designation	Extended functionality	Cat. No.	Ref. No.
		<b>GT-HE trip unit with:</b>	A choice of FIVE LT band shapes	GTG00NDX5SFXXXX	408755
		LT 0.2 - 1 x In =Ir	EF protection (UEF, SEF & REF)		
		Curve shapes: LT-C, LT-F, LT-I, LT-EI & LT-XI	Measurement unit <sup>(1)</sup>		
		LTDB	Relay functionality		
		ST I <sup>2</sup> T ON or OFF	RELT instantaneous		
		STDB	With standard instantaneous	GTG00NFx5SFXXXX	408763
		EF-(UEF & SEF) I <sup>2</sup> T ON or OFF	<i>Idem with Extended Instantaneous</i>		
		EFDB on UEF & SEF	A choice of FIVE LT band shapes	GTG00NDX8SFXXXX	408756
		EF-REF (instantaneous only)	EF protection (UEF, SEF & REF)		
		I or I ext.	Measurement unit <sup>(1)</sup>		
		RELT	Relay functionality & Wave form cap.		
		LT, ST, I and EF functions can be switched ON or OFF	RELT instantaneous		
		Multiple UEF, REF and SEF combinations possible.	Modbus communication		
			With standard instantaneous	GTG00NFx8SFXXXX	408764
			A choice of FIVE LT band shapes	GTG00NDX9SFXXXX	408757
			EF protection (UEF, SEF & REF)		
			Measurement unit <sup>(1)</sup>		
			Relay functionality		
			RELT instantaneous		
			Profibus communication		
			With standard instantaneous	GTG00NFx9SFXXXX	408765
			<i>Idem with extended instantaneous</i>		
			LT Band shape Choice (LTC or LTF)	GTG00NDT5SFXXXX	408750
			Dual GF protection (Res./Sum or CT)		
			Zone selective interlock on ST, I & GF		
			Measurement unit <sup>(1)</sup>		
			Relay functionality		
			RELT instantaneous		
			With standard instantaneous	GTG00NFT5SFXXXX	408758
			<i>Idem with extended instantaneous</i>		
			A choice of FIVE LT band shapes	GTG00NDT8SFXXXX	408751
			EF protection (UEF, SEF & REF)		
			Zone selective interlock on ST, I & GF		
			Measurement unit <sup>(1)</sup>		
			Relay functionality & Wave form cap.		
			RELT instantaneous		
			Modbus communication		
			With standard instantaneous	GTG00NFT8SFXXXX	408759
			<i>Idem with extended instantaneous</i>		
			A choice of FIVE LT band shapes	GTG00NDT9SFXXXX	408753
			EF protection (UEF, SEF & REF)		
			Zone selective interlock on ST, I & GF		
			Measurement unit <sup>(1)</sup>		
			Relay functionality		
			RELT instantaneous		
			Profibus communication		
			With standard instantaneous	GTG00NFT9SFXXXX	408761
			<i>Idem with extended instantaneous</i>		
		<b>GT-rating plug</b>	Required for all types	GTPUNI	408860





**Remark:**  
The GT-HE type offers five overload (LT) band choices:

- 1) LTC (Bimetal equivalent shape)
- 2) LTF (Fuse equivalent shape)
- 3) I (Inverse shape)
- 4) VI (Very inverse shape)
- 5) XI (Extremely inverse shape)

(1) An auxiliary power conditioner is obligatory when a fully functioning measurement is required see page A.26  
A special version of trip unit with magnetic only. Version available with ordering code GTG00KSXXSFXXXX. For details, please contact nearest sales office

## Internal accessories - Factory mounted

For field mounted variants see page A.24 and A.25

Motor operators <sup>(1)</sup>		Motor operator Type T		Motor operator Type 1		Motor operator Type 2 & 3			
		Cat. No.	Ref. No.	Cat. No.	Ref. No.	Cat. No.	Ref. No.		
	24V DC	GMT0024D	444630	GM01024D	407700	GM02024D	407725		
	48V DC	GMT0048D	444631	GM01048D	407702	GM02048D	407727		
	60V DC	GMT0060D	444248	GM01060D	407704	GM02060D	407729		
	110-130V DC	GMT0110D	444249	GM01110D	407706	GM02110D	407731		
	220V DC	GMT0220D	444251	GM01220D	407720	GM02220D	407722		
	250V DC	GMT0250D	444252	GM01250D	407708	GM02250D	407733		
	48V AC	GMT0048A	444247	GM01048A	407710	GM02048A	407735		
	110-130V AC	GMT0120A	444250	GM01120A	407712	GM02120A	407737		
	220-240V AC	GMT0240A	444638	GM01240A	407714	GM02240A	407739		
	380-415V AC	GMT0400A	444639	GM01400A	407716	GM02400A	407741		
	440V AC	GMT0440A	444640	GM01440A	407718	GM02440A	407743		
Closing coils		Closing coil				Comm. closing coil <sup>(2)</sup>			
	24V DC	GCCN024D	407861			GCCC024D	407836		
	48V AC-DC	GCCN048	407863			GCCC048	407838		
	60V DC	GCCN060D	407865			GCCC060D	407840		
	110-130V AC-DC	GCCN120	407867			GCCC120	407842		
	220-240V AC-DC	GCCN240	407869			GCCC240	407844		
	277V AC, 250V DC	GCCN277	407870			GCCC277	407849		
	380-415V AC	GCCN400A	407877			GCCC400A	407852		
	440V AC	GCCN440A	407878			GCCC440A	407853		
Releases		Undervoltage		Continuously rated / Shunt		Command Oper. Shunt		Impulse rated Shunt <sup>(3)</sup>	
	24V DC	GUVT024D	407795	GSTR024D	407770	GCSST024D	GSST024	407789	
	30V DC			GSTR030D	407786	GCSST030D			
	48V AC-DC	GUVT048	407797	GSTR048	407772	GCSST048			
	60V DC	GUVT060D	407799	GSTR060D	407774	GCSST060D			
	110-130V AC-DC	GUVT120	407801	GSTR120	407776	GCSST120	GSST120	407791	
	220-240V AC-DC (std)	GUVT240	407803	GSTR240	407778	GCSST240	GSST240	407793	
	220-240V AC-DC (60ms)	GUVR240	407811						
	277V AC, 250V DC	GUVT277	407805	GSTR277	407780	GCSST277			
	380-415V AC	GUVT400A	407807	GSTR400A	407782	GCSST400A			
	440V AC	GUVT440A	407809	GSTR440A	407784	GCSST440A			
Other coils		Remote reset coil <sup>(4)</sup>				Network interlock <sup>(5)(6)</sup>			
	24V DC	GRRC024D	407760						
	110V AC-DC	GRRC110	407762			GNTK120	407753		
	230V AC-DC	GRRC230	407764			GNTK240	407754		
Auxiliary contacts		Auxiliary contacts Type T		Auxiliary contacts Type 1/2/3					
	Power rated 3NO & 3NC Delivered as standard option in all EntelliGuard breakers and isolators	GTAS3	444655	GAS3	407885				
	Power rated 4NO & 4NC	GTAS4	444656						
	Power rated 8NO & 8NC			GAS6	407887				
	Power rated 3NO & 3NC + signal rated 2NO & 2NC			GAS5	407886				
	Power rated 4NO & 4NC + signal rated 4NO & 4NC			GAS8	407888				
Bell alarm contacts		Bell alarm Type T		Bell alarm Type 1/2/3					
	Power rated 1 changeover	GTBAT1	444660	GBAT1	407891				
	Signal rated 1 changeover	GTBATS1	444661	GBATS1	407890				
Indication contacts		Power rated wired through sec. discon.		Signal rated wired through sec. discon.		Signal rated wired trip unit (comm.)			
	CC/CCC/UVT/STR	GCSP1	407895			GCSP2	407896		
	Release indicator 1NO Breaker ready to close indic. <sup>(6)</sup> 1NO	GRTC1	407897	GRTC2	407899	GRTC3	407894		
	Breaker ready to close indic. <sup>(6)</sup> 1NC	GRTC4	407908	GRTC5	407909	GRTC6	407910		
Position indication contacts cassette		Cassette indication Type T		Cassette indication Type 1/2/3					
	1 changeover power rated 1NO/1NC	GTCPS1	444790	GCPS1	407922				
	2 changeover power rated 2NO/2NC	GTCPS2	444792	GCPS2	407923				
	2 changeover power rated 1NO/1NC & signal rated 1NO/1NC	GTCPSA	444794	GCPSA	407055				

(1) Motor spring charged indication contact supplied with motor operator  
 (2) The command closing coil is only available in the combination with 3NO and 3NC auxiliary contacts for frame T  
 Optionally the command closing coil can be accessed via the trip unit (communication bus)

(3) Must be used with an auxiliary contact  
 (4) The remote reset coil is not available in frame T, and not available as field mountable accessory for frames 1/2/3  
 (5) The network interlock is not available in frame T  
 (6) Not available as field mountable accessory



## Internal accessories - Factory mounted

For field mounted variants see page A.25



	Frame	Ronis/flat-shaped		Castell		Profalux/star-shaped	
		Cat. No.	Ref. No.	Cat. No.	Ref. No.	Cat. No.	Ref. No.
only provision	Mechanism mounted on Cassette						
	T	GTCRON	444669	NA	NA	GTCPRO	444668
	1						
	2	GCRON	407976	NA	NA	GCPRO	407980
	3						
	Mechanism mounted on Breaker						
T	GTBRON	444666	NA	NA	GTBPRO	444665	
2	GBRON	407971	GBCAS	407970	GBPRO	407978	
3							
provision + cylinder	Mechanism mounted on Cassette						
	T						
	1						
	2						
	3						
	Mechanism mounted on Breaker						
T	GBRON	407971	NA	NA	GBPRO	407978	
1	+	+	+	+	+	+	
2	GRON	410609	NA	NA	GPRO	407987	
3							
Locks with keys having random numbers (to be ordered separately)		GRON	410609	GCAS	407986	GPRO	407987

Pre-assembled interlocks for cables<sup>(2)</sup>

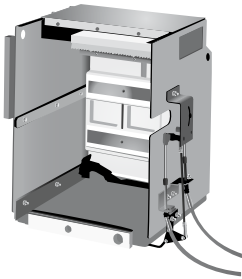

Type	Interlock scheme			Fixed pattern		Draw-out		
	Brk. 1	Brk. 2	Brk. 3	Cat. No.	Ref. No.	Cat. No.	Ref. No.	
Frame T <sup>(3)</sup>	A	OFF	OFF		For each breaker		For each breaker	
		ON	OFF		GT12FAD	444675	GT12WAD	444676
		OFF	ON					
	B	OFF	OFF	OFF	For each breaker		For each breaker	
		ON	OFF	OFF	GT13FB	444677	GT13WB	444678
		OFF	ON	OFF				
	C	OFF	OFF	ON	For each breaker		For each breaker	
		ON	ON	OFF	GT13FC	444679	GT13WC	444680
		OFF	ON	ON				
	D	ON	OFF	ON	For Brk. 1 & 3		For Brk. 1 & 3	
		ON	OFF	OFF	GT12FAD	444675	GT12WAD	444676
		OFF	OFF	ON	For Brk. 2		For Brk. 2	
Frames 1/2/3	A	OFF	OFF		For each breaker		For each breaker	
		ON	OFF		G12FAD	407900	G12WAD	407901
		OFF	ON					
	B	OFF	OFF	OFF	For each breaker		For each breaker	
		ON	OFF	OFF	G13FB	407902	G13WB	407903
		OFF	ON	OFF				
	C	OFF	OFF	ON	For each breaker		For each breaker	
		ON	ON	OFF	G13FC	407904	G13WC	407905
		OFF	ON	ON				
	D	ON	OFF	ON	For Brk. 1 & 3		For Brk. 1 & 3	
		ON	OFF	OFF	G12FAD	407900	G12WAD	407901
		OFF	OFF	ON	For Brk. 2		For Brk. 2	
	ON	OFF	ON	G13FDT	407906	G13WDT	407907	
	OFF	ON	OFF					

(1) For the separately available locks see page A.25, Kirk Lock version available on request

(2) The kits must be ordered complete with a breaker. To allow for installation and transport each kit is supplied as a field mountable unit customized for use with the ordered draw-out breaker cassette or a fixed pattern breaker. For the associated cables see page A.26

(3) For frame T, only the combination in the same frame size can be interlocked

NOTE: front fascia of breaker for frame 1/2/3 GPBD = 408040 (FIELD MOUNTED), 444782 = FACTORY MOUNTED

## Internal accessories - Factory mounted

Maximum amount of installable internal accessories







See page A.25



## Internal accessories - Field mountable

For factory mounted variants see page A.22 and A.23

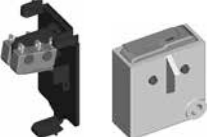
Order codes

Motor operators <sup>(1)</sup>		Motor operator Type T		Motor operator Type 1		Motor operator Type 2 & 3		
		Cat. No.	Ref. No.	Cat. No.	Ref. No.	Cat. No.	Ref. No.	
	24V DC	GMT0024DR	444641	GM01024DR	407701	GM02024DR	407726	
	48V DC	GMT0048DR	444642	GM01048DR	407703	GM02048DR	407728	
	60V DC	GMT0060DR	444643	GM01060DR	407705	GM02060DR	407730	
	110-130V DC	GMT0110DR	444644	GM01110DR	407707	GM02110DR	407732	
	220V DC	GMT0220DR	444645	GM01220DR	407721	GM02220DR	407723	
	250V DC	GMT0250DR	444646	GM01250DR	407709	GM02250DR	407734	
	48V AC	GMT0048AR	444647	GM01048DR	407711	GM02048DR	407736	
	110-130V AC	GMT0120AR	444648	GM01120AR	407713	GM02120AR	407738	
	220-240V AC	GMT0240AR	444649	GM01240AR	407715	GM02240AR	407740	
	380-415V AC	GMT0400AR	444650	GM01400AR	407717	GM02400AR	407742	
	440V AC	GMT0440AR	444651	GM01440AR	407719	GM02440AR	407744	
	Closing coils		Closing coil		Comm. closing coil <sup>(2)</sup>			
		24V DC	GCCN024DR	407860	GCC024DR		407835	
48V AC-DC		GCCN048R	407862	GCC048R		407837		
60V DC		GCCN060DR	407864	GCC060DR		407839		
110-130V AC-DC		GCCN120R	407866	GCC120R		407841		
220-240V AC-DC		GCCN240R	407868	GCC240R		407843		
277V AC, 250V DC		GCCN277R	407871	GCC277R		407850		
380-415V AC		GCCN400AR	407876	GCC400AR		407851		
440V AC		GCCN440AR	407879	GCC440AR		407854		
Releases		Undervoltage		Continuously rated / Shunt		Command Oper. Shunt		
	24V DC	GUVT024DR	407796	GSTR024DR	407771	GCSST024D	GSST024R 407790	
	30V DC			GSTR030DR	407787	GCSST030D		
	48V AC-DC	GUVT048R	407798	GSTR048R	407773	GCSST048		
	60V DC	GUVT060DR	407800	GSTR060DR	407775	GCSST060D		
	110-130V AC-DC	GUVT120R	407802	GSTR120R	407777	GCSST120	GSST120R 407792	
	220-240V AC-DC (std)	GUVT240R	407804	GSTR240R	407779	GCSST240	GSST240R 407794	
	220-240V AC-DC (60ms)	GUVR240R	407812					
	277V AC, 250V DC	GUVT277R	407806	GSTR277R	407781	GCSST277		
	380-415V AC	GUVT400AR	407808	GSTR400AR	407783	GCSST400A		
	440V AC	GUVT440AR	407810	GSTR440AR	407785	GCSST440A		
Auxiliary contacts		Auxiliary contacts Type T		Auxiliary contacts Type 1/2/3				
	Power Rated 3NO & 3NC (delivered as standard option in all EntelliGuard breakers & Isolators)	GTAS3R	444658	GAS3R	407880			
	Power rated 4NO & 4NC	GTAS4R	444659					
	Power rated 8NO & 8NC			GAS6R	407882			
	Power rated 3NO & 3NC + signal rated 2NO & 2NC			GAS5R	407881			
	Power rated 4NO & 4NC + signal rated 4NO & 4NC			GAS8R	407883			
Bell alarm contacts		Bell alarm Type T		Bell alarm Type 1/2/3				
	Power rated 1 changeover	GBAT1R	444672	GBAT1R	407889			
	Signal rated 1 changeover	GBATS1R	444673					
	Power rated 2 changeover			GBAT2R	-			
Indication contacts		Power rated wired through sec. discon.		Signal rated wired trip unit (comm.)				
	CC/CCC/UVT/STR release indicator 1NO	GCSP1R	407915	GCSP2R		407916		
	Position indication contacts cassette		Cassette indication Type T		Cassette indication Type 1/2/3			
	1 changeover power rated 1NO/1NC	GTCPS1R	444791	GCPS1R	407924			
	2 changeover power rated 2NO/2NC	GTCPS2R	444793	GCPS2R	407925			
	2 changeover power rated 1NO/1NC & signal rated 1NO/1NC	GTCPSAR	444795	GCPSAR	407056			
	4NO+4NC power rated			GCPS5R	407088			

(1) Motor spring charged indication contact supplied with motor operator

(2) The command closing coil is only available in the combination with 3NO and 3NC auxiliary contacts for frame T

The command closing coil does not come with push-button for EntelliGuard T frame

Optionally the command closing coil can be accessed via the trip unit (communication bus)

(3) Must be used with an auxiliary contact

NOTE: front fascia of breaker for frame 1/2/3 GPBD = 408040







## Internal accessories - Field mountable

Not available in a factory mounted variant

Field mountable cables for interlocking of breakers<sup>(1)</sup>



	Interlock Scheme		Cat. No.	Ref. No.
	No. of Cables Needed			
A	1 cable per breaker, choose length as indicated			
B	2 cables per breaker, choose length as indicated		Cable length 1 meter	GCB1 407990
			Cable length 1.5 meter	GCB2 407991
			Cable length 2 meter	GCB3 407992
C	2 cables per breaker, choose length as indicated		Cable length 2.5 meter	GCB4 407993
			Cable length 3 meter	GCB5 407994
			Cable length 3.5 meter	GCB6 407995
D	Brk's 1 and 3: 1 cable per breaker, choose length as indicated		Cable length 4 meter	GCB7 407996
	Brk. 2: 2 cables per breaker, choose length as indicated			

Time delay module for UVR release (TDM)



	Cat. No.	Ref. No.
60V DC	GTDM060D	407817
110-130V DC	GTDM120D	407819
220-240V DC	GTDM240D	407821
250V DC	GTDM250D	407823
48V AC	GTDM048A	407816
110-130V AC	GTDM120A	407818
220-240V AC	GTDM240A	407820
250-277V AC	GTDM277A	407822
380-415V AC	GTDM400A	407824
440V AC	GTDM440A	407825

Breaker earthing device for service

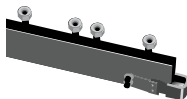

	3 pole		4 pole	
	Designation	Cat. No.	Designation	Ref. No.
EntelliGuard type 1	Maximum 1600A	G16H4ED 407930	G16H6ED	407931
	Maximum 2000A	G20H4ED 407932	G20H6ED	407933
EntelliGuard type 2	Maximum 4000A	G40M4ED 407934	G40M6ED	407935
	Maximum 6400A	G64M4ED 407936	G64M6ED	407937

GT- Accessories



Designation	Cat. No.	Ref. No.
Voltage conditioning unit 1 phase 220-230V	GMPU1	408790
Voltage conditioning unit 1 phase 380-400V	GMPU2	408791
Voltage conditioning unit 1 phase 240-250/277-290/415V <sup>(2)</sup>	GMPU3	408792
Voltage conditioning unit 690V <sup>(2)</sup>	GMPU4	408793
<b>CATALOG SOURCE VOLTAGE</b>		
<b>Position 1</b>	<b>Position 2</b>	<b>Position 3</b>
230	208	120
340	277	340
600	480	400
		GMPU5
		GMPU6
		GMPU7



Power Supply - Input 100-240V AC <sup>(2)</sup> or 100-353V DC - Output 24V DC 0.6 Amps <sup>(3)</sup>	GAPU	408789
--	------	--------

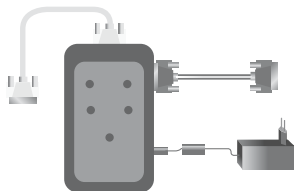

Trip unit, sealable transparent front cover	GTUS	408046
---	------	--------

Trip unit battery tester	GTUTK20	407999
--------------------------	---------	--------

Associated, setting and test software can be downloaded at [ex.geindustrial.com](http://ex.geindustrial.com)

Reduced energy let through switch	GTURSK	408780
Conversion kit to switch to manual reset TU lockout kit	GLKMR	-
Conversion kit to switch to automatic reset TU lockout kit	GLKAR	-

Wall mounting brackets



Wall mounting brackets for Env. 1 & 2	GFMTG	408085
---------------------------------------	-------	--------





(1) See for associated breaker and or cassette mounted kits page A.23

(2) 24V DC required for communications, earth fault, extended GF, date and time added to event log, RELT, and display turning on below 20% load

(3) For GF settings below 0.2 x In 24V DC aux. supply required

## Installation accessories

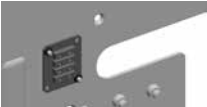
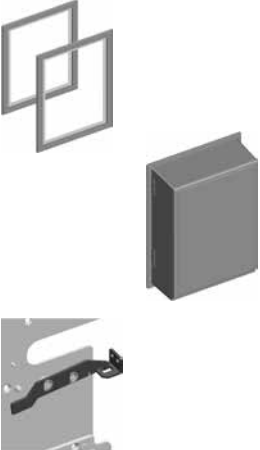
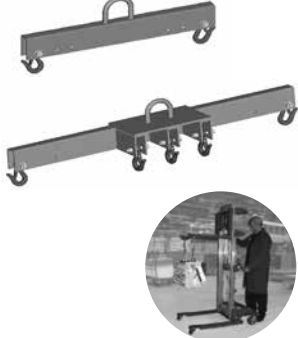
Not available in a factory mounted variant

Operation		Cat. No.	Ref. No.	
	<b>Front fascia of breaker</b> Padlocking device for push-buttons frame T	GTPBD	444667	
		<b>Operation indicators</b> Contact wear indicator env. 1-3	GCNTW	408036
			<b>Cassette</b> Mis insertion device frame T	GTREPM
Mis insertion device frames 1/2/3	GREPM		408041	
	<b>Door flange fixed frame T<sup>(1)</sup></b>	GTPRF	444805	
	Door flange fixed frames 1/2/3 <sup>(1)</sup>	GDPFR	408025	
	<b>Door flange draw-out frame T<sup>(1)</sup></b>	GTPRW	444806	
	Door flange draw-out frames 1/2/3 <sup>(1)</sup>	GDPRW	408026	
	<b>Door escutcheon IP54</b> EntelliGuard G fixed and draw-out frames 1/2/3	GGDEFD	287030	
	EntelliGuard G draw-out frame T	GTDEDT	287031	
	EntelliGuard G fixed frame T	GTDEFD	287032	
	<b>Door interlock</b> Door interlock frames 1/2/3	GLHDR	408039	
	Door interlock frames 1/2/3	GRHDR	408042	
	Door interlock on LEFT frame T	GTLHDR	444256	
Door interlock on RIGHT frame T	GTRHDR	444257		
	Breaker lifting beams suitable for 3P frame T, 1 & 2	GLD3F12	-	
	Breaker lifting beams suitable for 3P frame 3	GLD3F3	-	
	Breaker lifting beams suitable for 4P frame T, 1 & 2	GLD4F12	-	
	Breaker lifting beams suitable for 4P frame 3	GLD4F3	-	
	Lifting truck	GE-1000 <sup>(3)</sup>	-	
	Set of 9 phase separators for frames 1 & 2 (Needed for 1000V applications)	GJP	408057	
	Set of 9 phase separators for frame T	GTJP	444255	

(1) Is a spare, these devices are always supplied with the standard devices

(2) Designed for use with commercially available lifting equipment

The frame T is supplied with lifting handles

(3) To be procured from Burlington Plant

## Sensors for all GT type trip units

For use with ground fault residual (sum) protection  
Rogowski coils:



	Frames T & 1		Frame 2		Frame 3	
	Cat. No.	Ref. No.	Cat. No.	Ref. No.	Cat. No.	Ref. No.
400A	G04HNRC	408000	G04HNRC	408000		
630A	G07HNRC	408001	G07HNRC	408001		
800A	G08HNRC	408002	G08HNRC	408002		
1000A	G10HNRC	408003	G10HNRC	408003		
1250A	G13HNRC	408004	G13HNRC	408004		
1600A	G16HNRC	408005	G16HNRC	408005		
2000A	G20HNRC	408006	G20HNRC	408006		
2500A	G25HNRC	408007	G25MNRC	408162		
3200A			G32LNRC	408186	G32LNRC	408186
4000A			G40LNRC	408187	G40LNRC	408187
5000A					G50LNRC	408188
6400A					G64LNRC	408189

Order codes

## Sensors for GT-H and GT-HE type trip units

For use with ground fault protection, source ground return method  
Earth leg current transformers

- Kit includes 1 current transformer. An interposing current transformer is also required (supplied with trip unit)



	Frames T & 1		Frame 2		Frame 3	
	Cat. No.	Ref. No.	Cat. No.	Ref. No.	Cat. No.	Ref. No.
400A	G04HNCT	408300	G04HNCT	408300		
630A	G07HNCT	408301	G07HNCT	408301		
800A	G08HNCT	408302	G08HNCT	408302		
1000A	G10HNCT	408303	G10HNCT	408303		
1250A	G13HNCT	408304	G13HNCT	408304		
1600A	G16HNCT	408305	G16HNCT	408305		
2000A	G20HNCT	408306	G20HNCT	408306		
2500A			G25MNCT	408322		
3200A			G32LNCT	408331	G32LNCT	408331
4000A			G40LNCT	408332	G40LNCT	408332
5000A					G50LNCT	408333
6400A					G64LNCT	408334

A

B

C

D

E

F

X

## Cassettes for use with breakers and Isolators in draw-out pattern - Field mountable

- References apply for cassettes separately supplied for use with breakers or isolator
- With connection modes as indicated in left column
- Each cassette is supplied with safety shutters

### Cassettes for draw-out pattern; fixed portion only (continued)

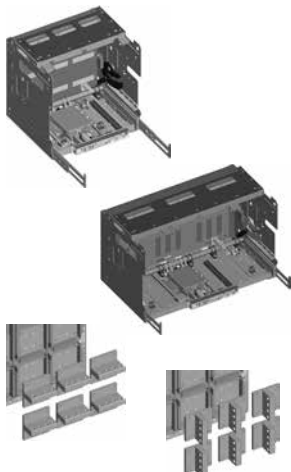
Universal rear connections	Suited for use with EntelliGuard G types	3 pole		4 pole <sup>(1)</sup>		
		Rating (A)	Cat. No.	Ref. No.	Cat. No.	Ref. No.
	<b>Cassette for frame T</b>					
	400 - 1600A	GT type R & K and G7 type R	GT16K2UXXXXR	444701	GT16K5UXXXXR	444704
	<b>Cassette for frame 1</b>					
	400 - 1600A	GG, GJ & GW type S	GG16S2UXXXXR	407617	GG16S5UXXXXR	407619
	1600A	GG, GJ & GW type N & H	GG16H2UXXXXR	407612	GG16H5UXXXXR	407615
	2000A	GG, GJ & GW type S, N & H	GG20H2UXXXXR	407622	GG20H5UXXXXR	407625
	2500A	GG, GJ & GW type S & F <sup>(2)</sup>	GG25H2UXXXXR	410681	GG25H5UXXXXR	410682
	<b>Cassette for frame 2<sup>(3)</sup></b>					
	400 - 2000A	GG, GJ & GW type N, E & M	GG20M2UXXXXR	407632	GG20M5UXXXXR	407635
	2500A	GG, GJ & GW type N, H & M	GG25M2UXXXXR	407642	GG25M5UXXXXR	407645
	3200A	GG, GJ & GW type N, H & M	GG32M2UXXXXR	407652	GG32M5UXXXXR	407656
	4000A	GG, GJ & GW type N, H & M	GG40M2UXXXXR	407666	GG40M5UXXXXR	407670
	Remark: each cassette is supplied with connection pads that can be rotated and used for vertical or horizontal connections.					
<b>Cassette for frame 3<sup>(4)</sup></b>						
3200 - 6400A <sup>(1)</sup>	GG & GJ type G, M & L	GG64L2UXXXXR	407686	GG64L5UXXXXR	407688	
<b>Horizontal rear connections</b>						
<b>Cassette for frame T</b>						
400 - 1600A	GT type R & K and G7 type R	GT16K2HXXXXR	444702	GT16K5HXXXXR	444705	
<b>Vertical rear connections</b>						
Cassette with dual vertical clusters and connection pads for limited derating frame 2.						
2500A	GG type F	GG25F2VXXXXR	410685	GG25F5VXXXXR	410686	
3200A	GH, GK, GJ & GZ type N, H & M	GH32M2VXXXXR	408254	GH32M5VXXXXR	408255	
4000A	GH, GK, GJ & GZ type N, H & M	GH40M2VXXXXR	408267	GH40M5VXXXXR	408268	
<b>Front access connections</b>						
<b>Cassette for frame T</b>						
400 - 1600A	GT type R & K and G7 type R	GT16K2FXXXXR	444700	GT16K5FXXXXR	444703	
<b>Cassette for frame 1</b>						
400 - 1600A	GG, GJ & GW type S	GG16S2FXXXXR	407627	GG16S5FXXXXR	407629	
1600A	GG, GJ & GW type N & H	GG16H2FXXXXR	407610	GG16H5FXXXXR	407613	
2000A	GG, GJ & GW type S, N & H	GG20H2FXXXXR	407620	GG20H5FXXXXR	407623	
2500A	GG, GJ & GW type S & F	GG25H2FXXXXR	410683	GG25H5FXXXXR	410684	
<b>Cassette for frame 2</b>						
400 - 2000A	GG, GJ & GW type E, N, H & M	GG20M2FXXXXR	407630	GG20M5FXXXXR	407633	
2500A	GG, GJ & GW type N, H & M	GG25M2FXXXXR	407640	GG25M5FXXXXR	407643	
3200A	GG, GJ & GW type N, H & M	GG32M2FXXXXR	407650	GG32M5FXXXXR	407654	
4000A	GG, GJ & GW type N, H & M	GG40M2FXXXXR	407658	GG40M5FXXXXR	407668	
<b>No Rear Copper</b>						
<b>Cassette for frame T</b>						
400 - 1600A	GT type R & K and G7 type R	GT16K2XXXXXR	444513	GT16K5XXXXXR	444515	
<b>Cassette for frame 1</b>						
400 - 1600A	GG, GJ & GW type S	GT16K2XXXXXR	444513	GT16K5XXXXXR	410630	
1600A	Type N: GG & GW; Type H: GG	GG16H2XXXXXR	410624	GG16H5XXXXXR	410626	
2000A	GG, GJ & GW type S, N & H	GG20H2XXXXXR	410632	GG20H5XXXXXR	410634	
<b>Cassette for frame 2<sup>(3)</sup></b>						
400 - 2000A	GG, GJ & GW type N, E & M	GG20M2XXXXXR	410636	GG20M5XXXXXR	410638	
2500A	GG, GJ & GW type N, H & M	GG25M2XXXXXR	410640	GG25M5XXXXXR	410642	
3200A	GG, GJ & GW type N, H & M	GG32M2XXXXXR	410644	GG32M5XXXXXR	410646	
4000A	GG, GJ & GW type N, H & M	GG40M2XXXXXR	410649	GG40M5XXXXXR	410650	
<b>Cassette for frame 3<sup>(4)</sup></b>						
3200 - 6400A <sup>(1)</sup>	GG & GJ type G, M & L	GG64L2XXXXXR	410652	GG64L5XXXXXR	410654	

(1) 4th pole on left

(2) Only connected in vertical mode, 2500A rating achieved

(3) Cassettes for frame 2 are limited to a current of **3200A when connected in horizontal mode**. Connected in vertical mode a 4000A rating is achieved

(4) The cassette for frame 3 is limited to a current of **5000A when connected in horizontal mode**

Connected in vertical mode it has a rating of 6400A. This cassette type is NOT depicted here

In Order to achieve temperature rise according to IEC standards, please ensure adequate size of busbar is used and a temperature rise test as per IEC standards is conducted inside Equipment



## Cassettes for draw-out pattern; fixed portion only

Rear Terminals		3 pole	
Rating (A)	Suited for use with EntelliGuard -G types	Cat. No.	Ref. No.
<i>To be ordered along with cassettes with NO rear terminals</i>			
400 - 1600A	Adapter connection frame 1 - 3P/4P - S & H	G20H1UNIR <sup>(1)</sup>	-
1600A	Adapter connection frame 1 - 3P/4P - S	G16H1UNIR <sup>(1)</sup>	-
2000A	Adapter connection frame 1 - 3P/4P - S, N & H	G20H1UNIR <sup>(1)</sup>	-
400A-2000A	Adapter connection frame 2 - 3P/4P - E,N,H&M	G32M1UNIR <sup>(1)</sup>	-
2500A	Adapter connection frame 2 - 3P/4P - N, H&M	G32M1UNIR <sup>(1)</sup>	-
3200A	Adapter connection frame 2 - 3P/4P - N, H&M	G32M1UNIR <sup>(1)</sup>	-
4000A	Adapter connection frame 2 - 3P/4P - N, H&M	G40M1RVIR <sup>(1)(2)</sup>	-
3200-6400A	Adapter connection frame 3 - 3P/4P - G, M & L	G64L1UNIR <sup>(1)</sup>	-
400A-1600A	Adapter connection frame T - 3P - G, M & L	GT16H3UNIR <sup>(3)</sup>	-
400A-1600A	Adapter connection frame T - 4P - G, M & L	GT16H7UNIR <sup>(3)</sup>	-

- (1) For 3 pole order 3 sets, for 4 pole order 4 sets
- (2) Only connected in vertical mode, 4000A rating is achieved
- (3) For 3 pole/4 pole order 1 set

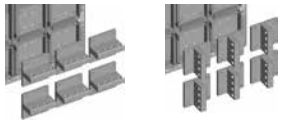

Intro

A

B

C

D





E

F

X

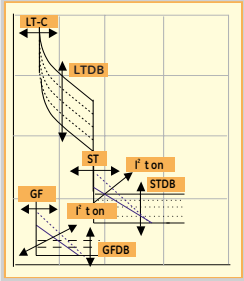

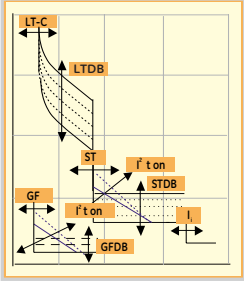
Field mounted (spare) trip units

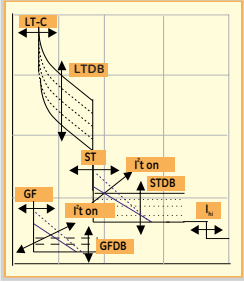
	Basic functionality	Designation	Extended functionality	Cat. No.	Ref. No.
		<b>GT-E trip unit with:</b> LT 0.2 - 1 x In = Ir LTDB ST I-T ON (3 bands) or OFF STDB GF sum I-T ON (3 bands) or OFF GFDB (on CT & Sum)	None	GTG00K2XXSRXXXX	408802
		<b>GT-rating plug</b>	Required for all T types	GTPUNI	408860
		<b>GT-S trip unit</b> LT 0.2 - 1 x In = Ir LTDB ST I-T ON (3 bands) or OFF STDB GF sum I-T ON (3 bands) or OFF GFDB (on CT & Sum)	Modbus communication	GTG00K4XX2XXXSR	408809
		<b>GT-rating plug</b>	Required for all types	GTPUNIVU0000	408860
		<b>GT-N trip unit</b> LT 0.2 - 1 x In = Ir LTDB ST I-T ON (3 bands) or OFF STDB GF sum I-T ON (3 bands) or OFF GFDB (on CT & Sum)	Measurement unit <sup>(1)</sup> Modbus communication Zone selective interlock on ST, I & GF	GTG00K4T6XXXXSR	408819
		<b>GT-rating plug</b>	Required for all types	GTPUNIVU0000	408860

(1) An auxiliary power conditioner is obligatory when a fully functioning measurement is required see page A.26  
 Note: GT-rating Plug required for all types GTPUNIR

## Field mounted (spare) trip units

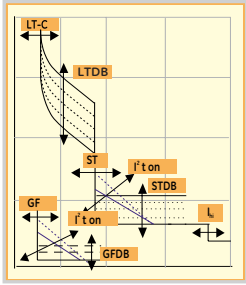
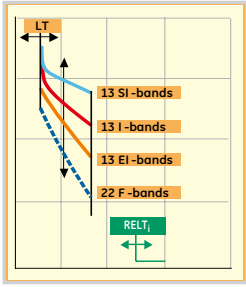
GT-H	Basic functionality	Designation	Extended functionality	Cat. No.	Ref. No.
		<b>GT-H trip unit with:</b>			
		LT 0.2 - 1 x In = Ir	A choice of FIVE LT band shapes	GTG00N5T8XXXXSR	408849
	Curve shapes: LT-C, LT-F, LT-I, LT-EI & LT-XI	Dual GF protection (Res/Sum or CT)	Zone selective interlock on ST, I & GF		
	LTDB	Measurement unit <sup>(1)</sup>	Relay functionality & Wave form cap.		
	ST I <sup>2</sup> T ON (3 bands) or OFF	REL instantaneous	Modbus communication		
	STDB	With standard instantaneous	Idem with extended instantaneous	GTG00N7T8XXXXSR	408851
	GF sum I <sup>2</sup> T ON (3 bands) or OFF	With/without alarm function <sup>(2)</sup>	A choice of FIVE LT band shapes	GTG00N5T9XXXXSR	408853
	With/without alarm function <sup>(2)</sup>	Dual GF protection (Res/Sum or CT)	Zone selective interlock on ST, I & GF		
	GFDB (on CT & Sum)	Measurement unit <sup>(1)</sup>	Relay functionality		
	I <sub>i</sub> or I ext.	REL instantaneous	Profibus communication		
REL	LT, ST, I, Gfsum, GFct and the alarm functions can be switched ON or OFF	With standard instantaneous	Idem with extended instantaneous	GTG00N7T9XXXXSR	408855
	A choice of FIVE LT band shapes		GTG00N6T8XXXXSR	408850	
	GFsum(+A) and GFct(+A) protection		Zone selective interlock on ST, I & GF		
	Measurement unit <sup>(1)</sup>		Relay functionality & Wave form cap.		
	REL instantaneous		Modbus communication		
With standard instantaneous		Idem with extended instantaneous	GTG00N8T8XXXXSR	408852	
A choice of FIVE LT band shapes		GFsum(+A) and GFct(+A) protection	GTG00N6T9XXXXSR	408854	
Zone selective interlock on ST, I & GF		Measurement unit <sup>(1)</sup>			
Relay functionality		REL instantaneous			
Profibus communication		With standard instantaneous	Idem with extended instantaneous	GTG00N8T9XXXXSR	408856
<b>GT-rating plug</b>		Required for all types	GTPUNIVU0000	408860	
<b>GT trip unit with NO protection</b>		For use with non automatic types with MCR	G3G00KAXXXXXSR	408796	

(1) An auxiliary power conditioner is obligatory when a fully functioning measurement is required see page A.26

(2) Closes a contact for use as an alarm signal









**Note: GT-rating Plug required for all types GTPUNIR**





Spare parts

Shutter Interlocks

14 <sup>th</sup> digit in Cat. Code	Shutter interlock		EntelliGuard G Frame T Cassette							
	T	Without lock cylinder - FLAT key	GTCRONS1	444670						
U	Without lock cylinder - STAR key	GTCPONS1	444671							
M	With lock cylinder - FLAT key	GTCRONS1	444670	GRON	410609					
N	With lock cylinder - STAR key	GTCPONS1	444671	GPRO	407987					
			EntelliGuard G Frame 1 Cassette							
T	Without lock cylinder - FLAT key	GCPRONS1 / GCPRONS2		407982						
U	Without lock cylinder - STAR key	GCPRONS1 / GCPRONS2		407982						
M	With lock cylinder - FLAT key	GCPRONS1 / GCPRONS2		407982		GRON	410609			
N	With lock cylinder - STAR key	GCPRONS1 / GCPRONS2		407982		GPRO	407987			
Breaker arc chutes										
			Frame T		Frame 1		Frame 2		Frame 3	
			Cat. No.	Ref. No.	Cat. No.	Ref. No.	Cat. No.	Ref. No.	Cat. No.	Ref. No.
	Arc chute for 1 pole	GT16KCHT	444801	G20HCHT	408102	G40MCHT	408131	G64LCHT	408144	
Breaker fixed arcing contacts										
	Set for 1 pole R & K types	GT16KARC	444802							
	Set for 1 pole S & N types			G20NARC	408104					
	Set for 1 pole H type			G20HARC	408098					
	Set for 1 pole E & N types					G40NARC	408172			
	Set for 1 pole H & M types					G40MARC	408169			
	Set for 1 pole L type							G64LARC	408193	
Cassette shutters										
	System with interlock 3 pole	GT16N2SSL	444253	G20H2SSL	407606	G40M2SSL	407636	G64L2SSL	407679	
	System with interlock 4 pole	GT16N5SSL	444254	G20H5SSL	407607	G40M5SSL	407637	G64L5SSL	407680	
Cassette racking handle										
	Spare racking handle	GTRHN	444803	GRHN	408043	GRHN	408043	GRHN	408043	
Breaker front facia part <sup>(1)</sup>										
	Front facia	GTFAL	444804	GFA4	408028	GFA4	408028	GFA4	408028	
	Set of 4 spare lock cams for use with Ronis 1104 locks			GRONCS	407984	GRONCS	407984	GRONCS	407984	
Cassette cluster contacts										
	<b>Sets per pole</b>									
	Current rating 400-1600A	GT16KCLS	444800							
	Current rating 400-1250A			G13HCLS	408097					
	Current rating 1600A			G16HCLS	408100					
	Current rating 2000-2500A			G20HCLS	408103					
	Current rating ≥2000A					G20MCLS	408106			
	Current rating 2500A					G25MCLS	408109			
	Current rating 3200A					G32MCLS	408117			
	Current rating 4000A					G40MCLS	408120			
	Current rating 4000-5000A							G50LCLS	408145	
Current rating 6400A							G64LCLS	408148		
Set of universal cluster pliers	GUNI	408047	GUNI	408047	GUNI	408047	GUNI	408047		
										
Breakers and cassette spare auxiliary disconnect plugs										
	For fixed breaker	GTSDFTR	444258	GSDFTR1	408052	GSDFTR1	408052	GSDFTR1	408052	
	1 39 pole "Block A"									
	For fixed Breaker			GSDFTR2	408030	GSDFTR2	408030	GSDFTR2	408030	
	1 78 pole "Block A and B"									
	For draw-out breaker	GTSDWTR	444259	GSDWTR	408054	GSDWTR	408054	GSDWTR	408054	
	1 39 pole set "Block A or B" <sup>(2)</sup>									
	For fixed breaker	GTHDTUF	444710							
	1 16 pole "Block C"									
For draw-out breaker	GTHDTUD	444711								
1 16 pole "Block C"										

(1) The original breaker serial number must be indicated on ordering

(2) Frames 1, 2 and 3 - two can be mounted

Frame T - one can be mounted

For a factory test report, please place ORDER an additional code of 403733



## Global catalogue number structure - Breaker

- Codes built in the indicated manner can be used as an alternative ordering method
- The breaker and its operation mode (manual or electrical)

Order codes

A

B

C

D

E

F

X

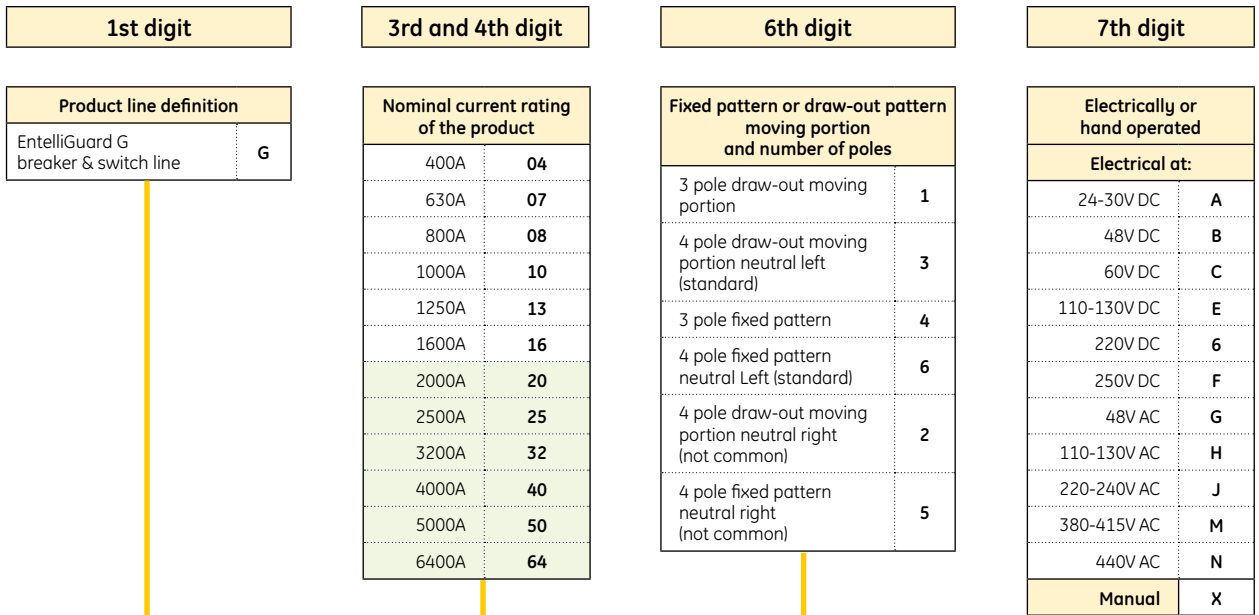

**G G 1 3 H 4 X X**

Product Type		Interruption / short-circuit withstand rating of the product				Voltage Rating		Standard closing coil	Command Closing coil <sup>(1)</sup>
		Icu = Ics	Icw	Code	Remarks				
Circuit breaker EntelliGuard G frame 1, 2 or 3	<b>G</b>					24V DC	<b>A</b>	<b>M</b>	
Circuit breaker EntelliGuard G frame T	<b>T</b>	50kA	42kA	<b>R</b>	Env. T	30V DC	<b>B</b>	<b>N</b>	
Circuit breaker EntelliGuard G with "limited derating"	<b>H</b>	50kA	50kA	<b>S</b>	Env. 1	48V AC-DC	<b>C</b>	<b>P</b>	
Non automatic (switch) EntelliGuard G frame 1, 2 or 3 with <b>NO MCR</b> <sup>(2)</sup>	<b>J</b>	65kA	50kA	<b>K</b>	Env. T	60V DC	<b>D</b>	<b>Q</b>	
Non automatic (switch) EntelliGuard G frame T with <b>NO MCR</b> <sup>(2)</sup>	<b>7</b>	65kA	65kA	<b>N</b>	Env. 1 & 2	110-130V AC-DC	<b>E</b>	<b>R</b>	
Non automatic (switch) EntelliGuard G frame 1, 2 or 3 <b>WITH MCR</b> <sup>(2)</sup>	<b>K</b>	85kA	65kA	<b>H</b>	Env. 1	220-240V AC-DC	<b>G</b>	<b>T</b>	
Non automatic (switch) EntelliGuard G with "limited derating" frame 1, 2 or 3 <b>WITH MCR</b> <sup>(2)</sup>	<b>W</b>	85kA	85kA	<b>E</b> <sup>(3)</sup>	Env. 2	250V DC 240-277V AC	<b>H</b>	<b>U</b>	
Non automatic (switch) EntelliGuard G with "limited derating" frame 1, 2 or 3 <b>WITH MCR</b> <sup>(2)</sup>	<b>Z</b>	85kA	85kA	<b>H</b> <sup>(3)</sup>	Env. 2	380-415V AC	<b>K</b>	<b>W</b>	
		100kA	85kA	<b>M</b>	Env. 2	440V AC	<b>L</b>	<b>Y</b>	
		100kA	100kA	<b>G</b>	Env. 3	<b>None</b>	<b>X</b>	<b>X</b>	
		150kA	100kA	<b>L</b>	Env. 3	If electrically operated add 1 closing coil by indicating voltage rating code. If manual use an X as indicated.			

Frame 1/2/3 only  
Frame T only

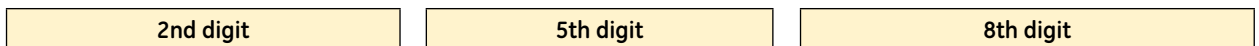

(1) Is supplied with a push-button for local breaker operation (fits on breaker front facia)  
 (2) MCR = Making Current Release; device that enhances the switches performance  
 (3) E used by devices ≤2000A, the H is used by devices of 2500, 3200 and 4000A



## Global catalogue number structure - Breaker

- Codes built in the indicated manner can be used as an alternative ordering method
- Breaker mounted accessories and trip unit

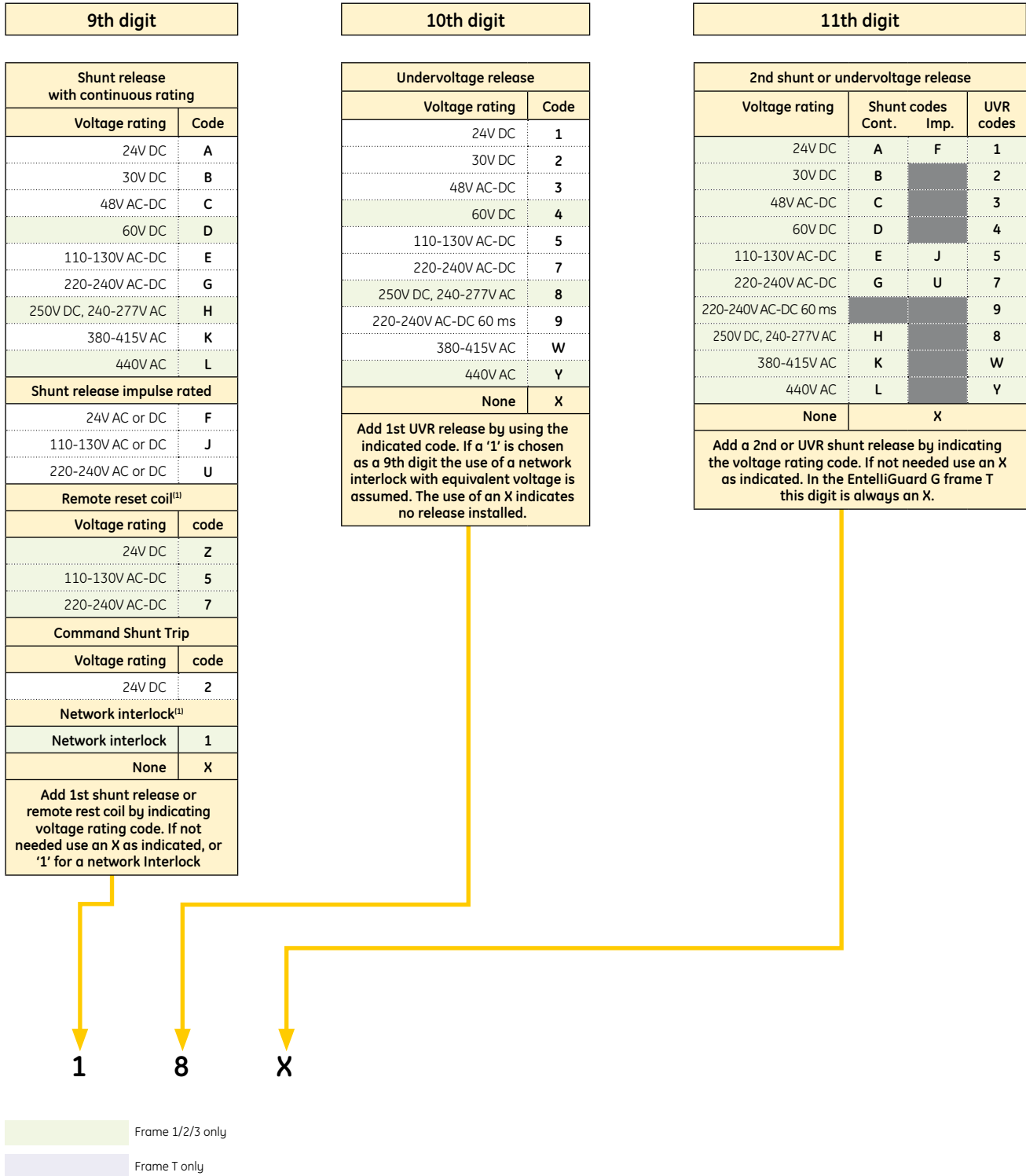

- A
- B
- C
- D
- E
- F
- X



## Global catalogue number structure - Breaker

- Codes built in the indicated manner can be used as an alternative ordering method
- The breaker and its operation mode (manual or electrical)

Order codes

Intro

A

B

C

D

E

F

X

12th digit												14th digit		
<b>Auxiliary switches &amp; configuration</b>												<b>Factory installed provision to mount a key lock on the breakers</b>		
Type	Code to be added <sup>(1)</sup>													
3NO+3NC (power rated) <sup>(2)</sup>	2	A	B	C	D	E	F	G	H	S	T	For Profalux key lock	P	
4NO+4NC (power rated)	3											For Ronis key lock	R	
8NO+8NC (power rated)	4											For large Castell type key lock	C	
3NO/3NC (power rated) + 2NO/2NC (signal)	6	J	K	L	M	N	P	Q	R	U	V	Push-button padlock device	L	
4NO/4NC (power rated) + 4NO/4NC (signal)	8											Large Castell key interlock and push-button padlock device	1	
<b>No other contacts installed</b> Coil signaling contact power (1 NO on secondary disconnect) - Close coil or command close coil Coil signaling contact high fidelity through trip unit - Close coil or command close coil Coil signaling contact power (1 NO on secondary disconnect) - 1st Shunt Coil signaling contact high fidelity through trip unit - 1st Shunt Coil signaling contact power (1 NO on secondary disconnect) - 1st UVR Coil signaling contact high fidelity through trip unit - 1st UVR Coil signaling contact power (1 NO on secondary disconnect) - 2nd ST or 2nd UVR Coil signaling contact high fidelity through trip unit - 2nd ST or 2nd UVR Coil signaling contact power (1 NO on secondary disconnect) - All installed devices CC/CC, ST, or UVR Coil signaling contact high fidelity through trip unit - All installed devices: CC/CC, ST, or UVR												Ronis key interlock and push-button padlock device	3	
												Profalux key interlock and push-button padlock device	4	
	<b>Factory mounted single key lock mounted on the breaker</b>													
													For Profalux key lock	Q
													For Ronis key lock	S
													Ronis key interlock and push-button padlock device	6
													Profalux key interlock and push-button padlock device	7
													No key lock or provision for one	X
<b>Designation</b>												<b>2 A X X</b>		
	<b>Code to be added<sup>(1)</sup></b>													
Bell alarm 1 NO power rated	A	D	E	F										
Bell alarm 1 NO signal rated	N	P	R	S										
Mechanical operations counter	B	K	L	M										
Bell alarm 1NO power rated & mechanical operations counter	C	G	H	J										
Bell alarm 1NO signal rated & mechanical operations counter	T	U	V	Y										
Ready to close contact 1 NO power rated on secondary terminals	1													
Ready to close contact 1 NO signal rated on secondary terminals	2													
Ready to close contact 1 NO signal rated connected through trip unit	3													
Ready to close contact 1 NC power rated on secondary terminals	4													
Ready to close contact 1 NC signal rated on secondary terminals	5													
Ready to close contact 1 NC signal rated connected through trip unit	6													
<b>None</b>	<b>X</b>													
<b>No other contacts installed</b> Ready to close contact 1 NO power rated on secondary terminals Ready to close contact 1 NO signal rated on Secondary terminals Ready to close contact 1 NO signal rated connected through trip unit														
<b>Factory installed provision to mount a cable interlock between breakers</b>														
												Mechanical interlock - Type A or D supply	1	
												Mechanical interlock type B all	2	
												Mechanical interlock type C all	3	
												Mechanical interlock type D tie only	4	
												No provision for breaker interlock	X	
												Factory installed provision to mount a cable interlock between breakers.		
<b>13th digit</b>												<b>15th digit</b>		

(1) Each standard breaker or Isolator is normally supplied with 3 NO+3 NC aux. contacts.



## Global catalogue number structure - Breaker

- Codes built in the indicated manner can be used as an alternative ordering method
- Breaker mounted accessories and trip unit

### 16th, 17th and 18th digit

Defines installed GT type electronic trip unit				Defines installed GT type electronic trip unit					
Basic type	Code	Functionality	Code	Basic type	Code	Functionality	Code		
GT-E with Ammeter	E	ST & STDB only	00	GT-H With measurement <sup>(1)</sup> RELT, Relaying and optional Modbus or Profibus communication	H	LT (CFI), LTDB, ST, STDB, I, GFsum, Gfct, GFDB + ZSI on ST, I, GFsum & GFct. + waveform capture + Modus rtu comm.	28		
		LT, LTDB, ST, STDB	01			LT (CFI), LTDB, ST, STDB, I, GFsum, Gfct, GFDB + ZSI on ST, I, GFsum & GFct. + Profibus DP communication.	29		
		LT, LTDB, ST, STDB, GF, GFDB	02			LT (CFI), LTDB, ST, STDB, I, GFsum (+A), Gfct (+A), GFDB	30		
GT-S with Ammeter and Optional Modbus communication	S	LT, LTDB, ST, STDB, I	06			LT (CFI), LTDB, ST, STDB, I, GFsum (+A), Gfct (+A), GFDB + waveform capture + Modus rtu comm.	31	LT (CFI), LTDB, ST, STDB, I, GFsum (+A), Gfct (+A), GFDB + waveform capture + Modus rtu comm.	32
		LT, LTDB, ST, STDB, I, GF, GFDB	07			LT (CFI), LTDB, ST, STDB, I, GFsum (+A), Gfct (+A), GFDB + ZSI on ST, I, GFsum & GFct.	33	LT (CFI), LTDB, ST, STDB, I, GFsum (+A), Gfct (+A), GFDB + ZSI on ST, I, GFsum & GFct. + Profibus DP communication	34
		LT, LTDB, ST, STDB, I, GF, GFDB + Modbus rtu communication	09			LT (CFI), LTDB, ST, STDB, I, GFsum (+A), Gfct (+A), GFDB + ZSI on ST, I, GFsum & GFct.	35	LT (CFI), LTDB, ST, STDB, I, + waveform capture + Modus rtu comm.	36
		LT, LTDB, ST, STDB, lext., GF, GFDB	03			LT (CFI), LTDB, ST, STDB, I, + Profibus DP communication	37	LT (CFI), LTDB, ST, STDB, I, GFsum, Gfct, GFDB + ZSI on ST, I, GFsum & GFct.	38
		LT, LTDB, ST, STDB, lext., GF, GFDB + Modbus rtu communication	05			LT (CFI), LTDB, ST, STDB, I, GFsum, Gfct, GFDB + ZSI on ST, I, GFsum & GFct. + Profibus DP communication	39	LT (CFI), LTDB, ST, STDB, I, UEf, SEf & REF + waveform capture + Modus rtu comm.	51
GT-N With measurement <sup>(2)</sup> RELT and optional Modbus communication	N	LT, LTDB, ST, STDB, I	08			LT (CFI), LTDB, ST, STDB, I, UEf, SEf & REF + waveform capture + Modus rtu comm.	55	LT (CFI), LTDB, ST, STDB, I, UEf, SEf & REF + Profibus DP communication	59
		LT, LTDB, ST, STDB, I, GF, GFDB	10			LT (CFI), LTDB, ST, STDB, I, UEf, SEf & REF + waveform capture + Modus rtu comm.	52	LT (CFI), LTDB, ST, STDB, I, UEf, SEf & REF + ZSI on ST, I, UEf	60
		LT, LTDB, ST, STDB, I, GF, GFDB + waveform capture	11			LT (CFI), LTDB, ST, STDB, I, UEf, SEf & REF + waveform capture + Modus rtu comm.	56	LT (CFI), LTDB, ST, STDB, I, UEf, SEf & REF + ZSI on ST, I, UEf	62
		LT, LTDB, ST, STDB, lext., GF, GFDB	04			LT (CFI), LTDB, ST, STDB, I, UEf, SEf & REF + waveform capture + Modus rtu comm.	53	LT (CFI), LTDB, ST, STDB, I, UEf, SEf & REF + ZSI on ST, I, UEf	
		LT, LTDB, ST, STDB, lext. GF, GFDB + ZSI on ST and GF + waveform capture + Modbus rtu comm.	12			LT (CFI), LTDB, ST, STDB, I, UEf, SEf & REF + waveform capture + Modus rtu comm.	57	LT (CFI), LTDB, ST, STDB, I, UEf, SEf & REF + ZSI on ST, I, UEf	
		LT, LTDB, ST, STDB, I, GFsum, Gfct, GFDB	13			LT (CFI), LTDB, ST, STDB, I, UEf, SEf & REF + waveform capture + Modus rtu comm.	61	LT (CFI), LTDB, ST, STDB, I, UEf, SEf & REF + ZSI on ST, I, UEf	
GT-H With measurement <sup>(2)</sup> RELT, Relaying and optional Modbus or Profibus communication	H	LT (CFI), LTDB, ST, STDB, lext, GFsum, Gfct, GFDB + waveform capture + Modus rtu comm.	14			LT (CFI), LTDB, ST, STDB, I, UEf, SEf & REF + waveform capture + Modus rtu comm.	58	LT (CFI), LTDB, ST, STDB, I, UEf, SEf & REF + ZSI on ST, I, UEf	
		LT (CFI), LTDB, ST, STDB, lext, GFsum, Gfct, GFDB	15			LT (CFI), LTDB, ST, STDB, I, UEf, SEf & REF + waveform capture + Modus rtu comm.	62		
		LT (CFI), LTDB, ST, STDB, lext, GFsum, Gfct, GFDB + Profibus DP communication	16						
		LT (CFI), LTDB, ST, STDB, lext, GFsum, Gfct, GFDB + ZSI on ST, lext. GFsum & GFct.	17						
		LT (CFI), LTDB, ST, STDB, lext, GFsum, Gfct, GFDB + ZSI on ST, lext. GFsum & GFct. + waveform capture + Modus rtu comm.	18						
		LT (CFI), LTDB, ST, STDB, lext, GFsum (+A), Gfct (+A), GFDB	19						
		LT (CFI), LTDB, ST, STDB, lext, GFsum (+A), Gfct (+A), GFDB + waveform capture + Modus rtu comm.	20						
		LT (CFI), LTDB, ST, STDB, lext, GFsum (+A), Gfct (+A), GFDB + Profibus DP comm.	21						
		LT (CFI), LTDB, ST, STDB, lext, GFsum (+A), Gfct (+A), GFDB + ZSI on ST, lext. GFsum & GFct.	22						
		LT (CFI), LTDB, ST, STDB, lext, GFsum (+A), Gfct (+A), GFDB + ZSI on ST, lext. GFsum & GFct. + waveform capture + Modus rtu comm.	23						
		LT (CFI), LTDB, ST, STDB, I	24						
		LT (CFI), LTDB, ST, STDB, I, GFsum, Gfct, GFDB	25						
		LT (CFI), LTDB, ST, STDB, I, GFsum, Gfct, GFDB + waveform capture + Modus rtu comm.	26						
		LT (CFI), LTDB, ST, STDB, I, GFsum, Gfct, GFDB + Profibus DP communication	27						

Remarks on global catalogue number: the 18 digit catalogue number covers an assembled and packed Power Circuit Breaker with a tri lingual User Manual.  
 For more information, you can visit our website.  
 United Kingdom: uk.geindustrial.com  
 Middle East: ex.geindustrial.com

#### Remarks on installed trip unit types:

- when instantaneous (I) or extended instantaneous (HI) is present in any of the trip unit variants it is always switchable (can be switched off)
- in the Trip unit variants GT-L, GT-E, GT-S and GT-N all other protection devices (LT, ST, GF) are non switchable (cannot be switched off)
- in the Trip unit variants GT-H and GT-HE and extended LT protection device is included (Breaker, Fuse and three Inverse curve shapes)
- all protection devices (LT+, ST, GFsum, GFsumA, Gfct, GFctA, I, HI) are switchable (can be switched off)



## Global catalogue number structure - Cassette

- Codes built in the indicated manner can be used as an alternative ordering method
- Cassettes supplied together with the breaker

Order codes

Intro

A

B

C

D

E

F

X

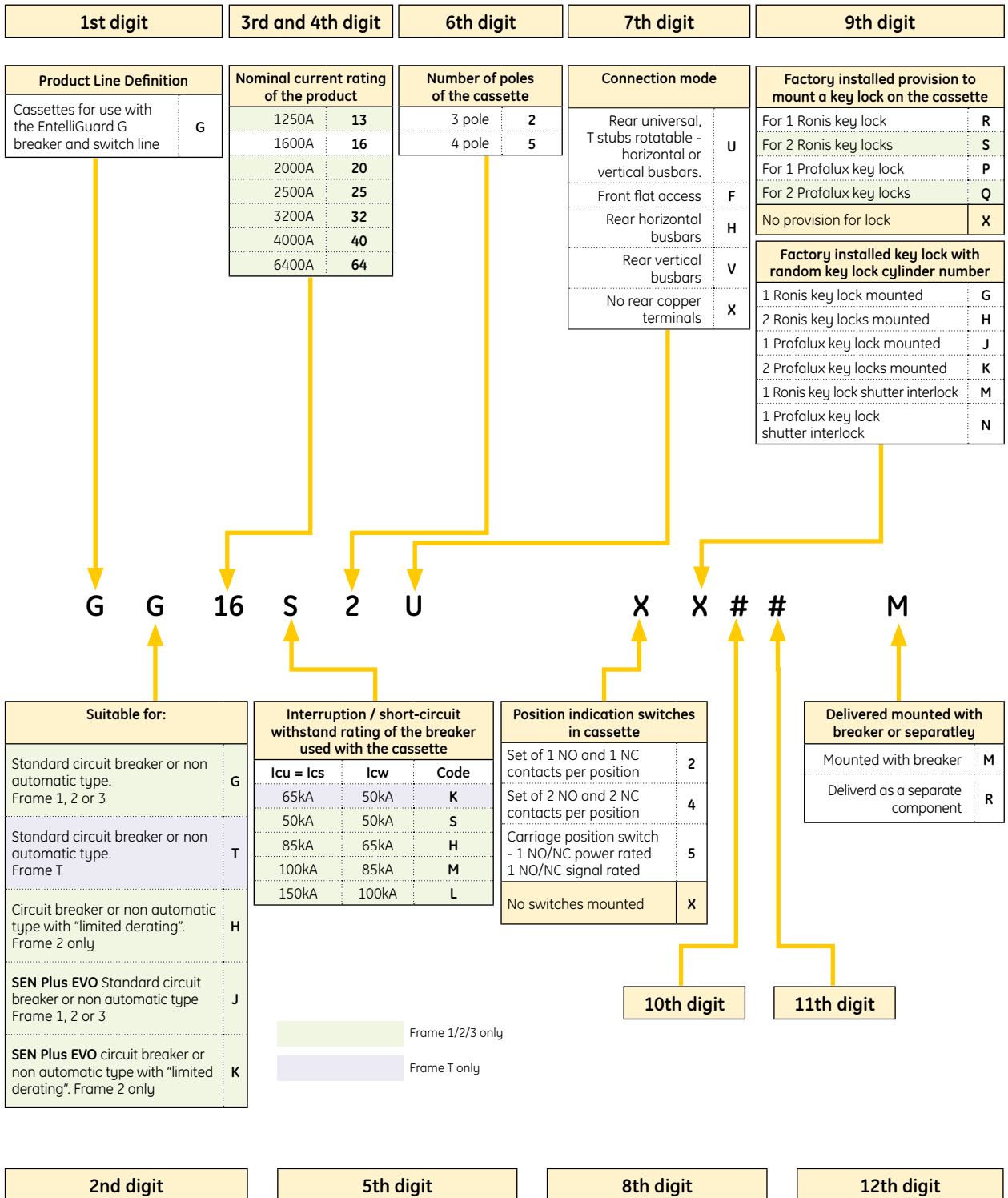

## Valid catalogue number combinations - 3 pole breakers

3 pole breakers - Fixed mounting pattern and draw-out pattern.

3 pole - Fixed mounting pattern					
Cat. No	Ref. No.	Page	Cat. No	Ref. No.	Page
GT04R4	444542	A.4	GG16M4	407160	A.5
GT07R4	444543	A.4	GG20M4	407200	A.5
GT08R4	444544	A.4	GG25M4	407236	A.5
GT10R4	444545	A.4	GG32M4	407262	A.5
GT13R4	444546	A.4	GG40M4	407288	A.5
GT16R4	444547	A.4	GG32G4	407252	A.5
GG04S4	407019	A.4	GG40G4	407270	A.5
GG07S4	407048	A.4	GG50M4	407306	A.5
GG08S4	407078	A.4	GG64M4	407326	A.5
GG10S4	407108	A.4	GG32L4	407254	A.5
GG13S4	407138	A.4	GG40L4	407284	A.5
GG16S4	407168	A.4	GG50L4	407302	A.5
GG20S4	407208	A.4	GG64L4	407322	A.5
GG25S4	410655	A.4	G704R4	444616	A.6
GT04K4	444548	A.4	G707R4	444617	A.6
GT07K4	444549	A.4	G708R4	444618	A.6
GT08K4	444550	A.4	G710R4	444619	A.6
GT10K4	444551	A.4	G713R4	444620	A.6
GT13K4	444552	A.4	G716R4	444621	A.6
GT16K4	444553	A.4	GJ04S4	407380	A.6
GG25F4	410658	A.4	GJ07S4	407400	A.6
GG04N4	407015	A.4	GJ08S4	407420	A.6
GG07N4	407044	A.4	GJ10S4	407440	A.6
GG08N4	407074	A.4	GJ13S4	407460	A.6
GG10N4	407104	A.4	GJ16S4	407480	A.6
GG13N4	407134	A.4	GJ20S4	407500	A.6
GG16N4	407164	A.4	GJ25S4	410673	A.6
GG20N4	407204	A.4	GW04N4	407376	A.6
GG25N4	407240	A.4	GW07N4	407396	A.6
GG32N4	407266	A.4	GW08N4	407416	A.6
GG40N4	407292	A.4	GW10N4	407436	A.6
GG04H4	407007	A.4	GW13N4	407456	A.6
GG07H4	407036	A.4	GW16N4	407476	A.6
GG08H4	407066	A.4	GW20N4	407496	A.6
GG10H4	407096	A.4	GJ25N4	407520	A.6
GG13H4	407126	A.4	GJ32N4	407539	A.6
GG16H4	407156	A.4	GJ40N4	407560	A.6
GG20H4	407196	A.4	GW04M4	408350	A.6
GG04E4	407003	A.4	GW07M4	408352	A.6
GG07E4	407032	A.4	GW08M4	408354	A.6
GG08E4	407062	A.4	GW10M4	408356	A.6
GG10E4	407092	A.4	GW13M4	408358	A.6
GG13E4	407122	A.4	GW16M4	408360	A.6
GG16E4	407152	A.4	GW20M4	408362	A.6
GG20E4	407192	A.4	GW25M4	408364	A.6
GG25H4	407232	A.4	GW32M4	408366	A.6
GG32H4	407244	A.4	GW40M4	408368	A.6
GG40H4	407280	A.4	GW25F4	410661	A.6
GG04M4	407011	A.5	GJ32L4	407535	A.6
GG07M4	407040	A.5	GJ40L4	407556	A.6
GG08M4	407070	A.5	GJ50L4	407567	A.6
GG10M4	407100	A.5	GJ64L4	407577	A.6
GG13M4	407130	A.5			

3 pole - Draw-out pattern					
Cat. No	Ref. No.	Page	Cat. No	Ref. No.	Page
GT04R1	444500	A.9	GG32G1	407250	A.10
GT07R1	444501	A.9	GG40G1	407268	A.10
GT08R1	444502	A.9	GG50M1	407304	A.10
GT10R1	444503	A.9	GG64M1	407324	A.10
GT13R1	444504	A.9	GG32L1	407248	A.10
GT16R1	444505	A.9	GG40L1	407282	A.10
GG04S1	407017	A.9	GG50L1	407300	A.10
GG07S1	407046	A.9	GG64L1	407320	A.10
GG08S1	407076	A.9	GH32N1	407350	A.11
GG10S1	407106	A.9	GH40N1	407356	A.11
GG13S1	407136	A.9	GH32H1	407346	A.11
GG16S1	407166	A.9	GH40H1	407352	A.11
GG20S1	407206	A.9	GH32M1	407348	A.11
GG25S1	410664	A.9	GH40M1	407354	A.11
GT04K1	444506	A.9	G704R1	444585	A.12
GT07K1	444507	A.9	G707R1	444586	A.12
GT08K1	444508	A.9	G708R1	444587	A.12
GT10K1	444509	A.9	G710R1	444588	A.12
GT13K1	444510	A.9	G713R1	444589	A.12
GT16K1	444511	A.9	G716R1	444590	A.12
GG04N1	407013	A.9	GJ04S1	407378	A.12
GG07N1	407042	A.9	GJ07S1	407398	A.12
GG08N1	407072	A.9	GJ08S1	407418	A.12
GG10N1	407102	A.9	GJ10S1	407438	A.12
GG13N1	407132	A.9	GJ13S1	407458	A.12
GG16N1	407162	A.9	GJ16S1	407478	A.12
GG20N1	407202	A.9	GJ20S1	407498	A.12
GG25N1	407238	A.9	GJ25S1	410674	A.12
GG32N1	407264	A.9	GW04N1	407374	A.12
GG40N1	407290	A.9	GW07N1	407394	A.12
GG25F1	410667	A.9	GW08N1	407414	A.12
GG04H1	407005	A.9	GW10N1	407434	A.12
GG07H1	407034	A.9	GW13N1	407454	A.12
GG08H1	407064	A.9	GW16N1	407474	A.12
GG10H1	407094	A.9	GW20N1	407494	A.12
GG13H1	407124	A.9	GW25F1	410670	A.12
GG16H1	407154	A.9	GJ25N1	407518	A.12
GG20H1	407194	A.9	GJ32N1	407537	A.12
GG04E1	407001	A.9	GJ40N1	407558	A.12
GG07E1	407030	A.9	GW04M1	408400	A.12
GG08E1	407060	A.9	GW07M1	408402	A.12
GG10E1	407090	A.9	GW08M1	408404	A.12
GG13E1	407120	A.9	GW10M1	408406	A.12
GG16E1	407150	A.9	GW13M1	408408	A.12
GG20E1	407190	A.9	GW16M1	408410	A.12
GG25H1	407230	A.9	GW20M1	408412	A.12
GG32H1	407242	A.9	GW25M1	408414	A.12
GG40H1	407278	A.9	GW32M1	408416	A.12
GG04M1	407009	A.10	GW40M1	408418	A.12
GG07M1	407038	A.10	GW25F1	410670	A.12
GG08M1	407068	A.10	GJ32L1	407533	A.12
GG10M1	407098	A.10	GJ40L1	407554	A.12
GG13M1	407128	A.10	GJ50L1	407565	A.12
GG16M1	407158	A.10	GJ64L1	407575	A.12
GG20M1	407198	A.10	GK32N1	407591	A.13
GG25M1	407234	A.10	GK40N1	407595	A.13
GG32M1	407260	A.10	GZ32H1	407589	A.13
GG40M1	407286	A.10	GZ40H1	407593	A.13



## Valid catalogue number combinations

4 pole breakers - Fixed mounting pattern.

Order codes

Intro

A

B

C

D

E

F

X

4 pole - Fixed mounting pattern - Left Neutral					
Cat. No	Ref. No.	Page	Cat. No	Ref. No.	Page
GT04R6	444563	A.4	GG16M6	407161	A.5
GT07R6	444564	A.4	GG20M6	407201	A.5
GT08R6	444565	A.4	GG25M6	407237	A.5
GT10R6	444566	A.4	GG32M6	407263	A.5
GT13R6	444567	A.4	GG40M6	407289	A.5
GT16R6	444568	A.4	GG32G6	407253	A.5
GG04S6	407020	A.4	GG40G6	407271	A.5
GG07S6	407049	A.4	GG50M6	407307	A.5
GG08S6	407079	A.4	GG64M6	407327	A.5
GG10S6	407109	A.4	GG32L6	407255	A.5
GG13S6	407139	A.4	GG40L6	407285	A.5
GG16S6	407169	A.4	GG50L6	407303	A.5
GG20S6	407209	A.4	GG64L6	407323	A.5
GG25S6	410657	A.4	G704R6	444632	A.6
GT04K6	444569	A.4	G707R6	444633	A.6
GT07K6	444570	A.4	G708R6	444634	A.6
GT08K6	444571	A.4	G710R6	444635	A.6
GT10K6	444572	A.4	G713R6	444636	A.6
GT13K6	444573	A.4	G716R6	444637	A.6
GT16K6	444574	A.4	GJ04S6	407381	A.6
GG04N6	407016	A.4	GJ07S6	407401	A.6
GG07N6	407045	A.4	GJ08S6	407421	A.6
GG08N6	407075	A.4	GJ10S6	407441	A.6
GG10N6	407105	A.4	GJ13S6	407461	A.6
GG13N6	407135	A.4	GJ16S6	407481	A.6
GG16N6	407165	A.4	GJ20S6	407501	A.6
GG20N6	407205	A.4	GJ25S6	410662	A.6
GG25N6	407241	A.4	GW04N6	407377	A.6
GG32N6	407267	A.4	GW07N6	407397	A.6
GG40N6	407293	A.4	GW08N6	407417	A.6
GG04H6	407008	A.4	GW10N6	407437	A.6
GG07H6	407037	A.4	GW13N6	407457	A.6
GG08H6	407067	A.4	GW16N6	407477	A.6
GG10H6	407097	A.4	GW20N6	407497	A.6
GG13H6	407127	A.4	GJ25N6	407521	A.6
GG16H6	407157	A.4	GJ32N6	407540	A.6
GG20H6	407197	A.4	GJ40N6	407561	A.6
GG04E6	407004	A.4	GW04M6	408351	A.6
GG07E6	407033	A.4	GW07M6	408353	A.6
GG08E6	407063	A.4	GW08M6	408355	A.6
GG10E6	407093	A.4	GW10M6	408357	A.6
GG13E6	407123	A.4	GW13M6	408359	A.6
GG16E6	407153	A.4	GW16M6	408361	A.6
GG20E6	407193	A.4	GW20M6	408363	A.6
GG25H6	407233	A.4	GW25M6	408365	A.6
GG32H6	407245	A.4	GW32M6	408367	A.6
GG40H6	407281	A.4	GW40M6	408369	A.6
GG04M6	407012	A.5	GW25F6	410663	A.6
GG07M6	407041	A.5	GJ32L6	407536	A.6
GG08M6	407071	A.5	GJ40L6	407557	A.6
GG10M6	407101	A.5	GJ50L6	407568	A.6
GG13M6	407131	A.5	GJ64L6	407578	A.6

4 pole - Fixed mounting pattern - Right Neutral					
Cat. No	Ref. No.	Page	Cat. No	Ref. No.	Page
GT04R5	444740	A.4	GG16M5	408495	A.5
GT07R5	444741	A.4	GG20M5	408515	A.5
GT08R5	444742	A.4	GG25M5	408528	A.5
GT10R5	444743	A.4	GG32M5	408547	A.5
GT13R5	444744	A.4	GG40M5	408567	A.5
GT16R5	444745	A.4	GG32G5	408541	A.5
GG04S5	408379	A.4	GG40G5	408561	A.5
GG07S5	408399	A.4	GG50M5	408583	A.5
GG08S5	408439	A.4	GG64M5	408587	A.5
GG10S5	408449	A.4	GG32L5	408545	A.5
GG13S5	408459	A.4	GG40L5	408565	A.5
GG16S5	408499	A.4	GG50L5	408581	A.5
GG20S5	408519	A.4	GG64L5	408585	A.5
GG25S5	410656	A.4	G704R5	444775	A.6
GT04K5	444746	A.4	G707R5	444776	A.6
GT07K5	444747	A.4	G708R5	444777	A.6
GT08K5	444748	A.4	G710R5	444778	A.6
GT10K5	444749	A.4	G713R5	444779	A.6
GT13K5	444750	A.4	G716R5	444780	A.6
GT16K5	444751	A.4	GJ04S5	408612	A.6
GG04N5	408377	A.4	GJ07S5	408616	A.6
GG07N5	408397	A.4	GJ08S5	408620	A.6
GG08N5	408437	A.4	GJ10S5	408627	A.6
GG10N5	408447	A.4	GJ13S5	408635	A.6
GG13N5	408457	A.4	GJ16S5	408639	A.6
GG16N5	408497	A.4	GJ20S5	408643	A.6
GG20N5	408517	A.4	GW04N5	408613	A.6
GG25N5	408530	A.4	GW07N5	408617	A.6
GG32N5	408549	A.4	GW08N5	408621	A.6
GG40N5	408569	A.4	GW10N5	408628	A.6
GG04H5	408373	A.4	GW13N5	408636	A.6
GG07H5	408393	A.4	GW16N5	408640	A.6
GG08H5	408433	A.4	GW20N5	408644	A.6
GG10H5	408443	A.4	GW04M5	408712	A.6
GG13H5	408453	A.4	GW07M5	408651	A.6
GG16H5	408493	A.4	GW08M5	408655	A.6
GG20H5	408513	A.4	GW10M5	408659	A.6
GG04E5	408371	A.4	GW13M5	408668	A.6
GG07E5	408391	A.4	GW16M5	408672	A.6
GG08E5	408431	A.4	GW20M5	408676	A.6
GG10E5	408441	A.4	GW25M5	408685	A.6
GG13E5	408451	A.4	GW32M5	408691	A.6
GG16E5	408491	A.4	GW40M5	408697	A.6
GG20E5	408511	A.4	GJ32L5	408721	A.6
GG25H5	408526	A.4	GJ40L5	408723	A.6
GG32H5	408543	A.4	GJ50L5	408725	A.6
GG40H5	408563	A.4	GJ64L5	408727	A.6
GG04M5	408375	A.5	GJ25N5	408683	A.6
GG07M5	408395	A.5	GJ32N5	408689	A.6
GG08M5	408435	A.5	GJ40N5	408695	A.6
GG10M5	408445	A.5	GW25F5	410690	A.6
GG13M5	408455	A.5			





## Valid catalogue number combinations

4 pole breakers - Draw-out pattern.

4 pole - Draw-out pattern - Left Neutral					
Cat. No	Ref. No.	Page	Cat. No	Ref. No.	Page
GT04R3	444520	A.9	GG32G3	407251	A.10
GT07R3	444521	A.9	GG40G3	407269	A.10
GT08R3	444522	A.9	GG50M3	407305	A.10
GT10R3	444523	A.9	GG64M3	407325	A.10
GT13R3	444524	A.9	GG32L3	407249	A.10
GT16R3	444525	A.9	GG40L3	407283	A.10
GG04S3	407018	A.9	GG50L3	407301	A.10
GG07S3	407047	A.9	GG64L3	407321	A.10
GG08S3	407077	A.9	GH32N3	407351	A.11
GG10S3	407107	A.9	GH40N3	407357	A.11
GG13S3	407137	A.9	GH32H3	407347	A.11
GG16S3	407167	A.9	GH40H3	407353	A.11
GG20S3	407207	A.9	GH32M3	407349	A.11
GG25S3	410666	A.9	GH40M3	407355	A.11
GT04K3	444526	A.9	G704R3	444600	A.12
GT07K3	444527	A.9	G707R3	444601	A.12
GT08K3	444528	A.9	G708R3	444602	A.12
GT10K3	444529	A.9	G710R3	444603	A.12
GT13K3	444530	A.9	G713R3	444604	A.12
GT16K3	444531	A.9	G716R3	444605	A.12
GG04N3	407014	A.9	GJ04S3	407379	A.12
GG07N3	407043	A.9	GJ07S3	407399	A.12
GG08N3	407073	A.9	GJ08S3	407419	A.12
GG10N3	407103	A.9	GJ10S3	407439	A.12
GG13N3	407133	A.9	GJ13S3	407459	A.12
GG16N3	407163	A.9	GJ16S3	407479	A.12
GG20N3	407203	A.9	GJ20S3	407499	A.12
GG25N3	407239	A.9	GJ25S3	410672	A.12
GG32N3	407265	A.9	GW04N3	407375	A.12
GG40N3	407291	A.9	GW07N3	407395	A.12
GG25F3	410669	A.9	GW08N3	407415	A.12
GG04H3	407006	A.9	GW10N3	407435	A.12
GG07H3	407035	A.9	GW13N3	407455	A.12
GG08H3	407065	A.9	GW16N3	407475	A.12
GG10H3	407095	A.9	GW20N3	407495	A.12
GG13H3	407125	A.9	GW25F3	410671	A.12
GG16H3	407155	A.9	GJ25N3	407519	A.12
GG20H3	407195	A.9	GJ32N3	407538	A.12
GG04E3	407002	A.9	GJ40N3	407559	A.12
GG07E3	407031	A.9	GW04M3	408401	A.12
GG08E3	407061	A.9	GW07M3	408403	A.12
GG10E3	407091	A.9	GW08M3	408405	A.12
GG13E3	407121	A.9	GW10M3	408407	A.12
GG16E3	407151	A.9	GW13M3	408409	A.12
GG20E3	407191	A.9	GW16M3	408411	A.12
GG25H3	407231	A.9	GW20M3	408413	A.12
GG32H3	407273	A.9	GW25M3	408415	A.12
GG40H3	407279	A.9	GW32M3	408417	A.12
GG04M3	407010	A.10	GW40M3	408419	A.12
GG07M3	407039	A.10	GW25F3	410671	A.12
GG08M3	407069	A.10	GJ32L3	407534	A.12
GG10M3	407099	A.10	GJ40L3	407555	A.12
GG13M3	407129	A.10	GJ50L3	407566	A.12
GG16M3	407159	A.10	GJ64L3	407576	A.12
GG20M3	407199	A.10	GK32N3	407592	A.13
GG25M3	407235	A.10	GK40N3	407596	A.13
GG32M3	407261	A.10	GZ32H3	407590	A.13
GG40M3	407287	A.10	GZ40H3	407594	A.13

4 pole - Draw-out pattern - Right Neutral					
Cat. No	Ref. No.	Page	Cat. No	Ref. No.	Page
GT04R2	444720	A.9	GG25M2	408527	A.10
GT07R2	444721	A.9	GG32M2	408546	A.10
GT08R2	444722	A.9	GG40M2	408566	A.10
GT10R2	444723	A.9	GG32G2	408540	A.10
GT13R2	444724	A.9	GG40G2	408560	A.10
GT16R2	444725	A.9	GG50M2	408582	A.10
GG04S2	408378	A.9	GG64M2	408586	A.10
GG07S2	408398	A.9	GG32L2	408544	A.10
GG08S2	408438	A.9	GG40L2	408564	A.10
GG10S2	408448	A.9	GG50L2	408580	A.10
GG13S2	408458	A.9	GG64L2	408584	A.10
GG16S2	408498	A.9	G704R2	444720	A.12
GG20S2	408518	A.9	G707R2	444721	A.12
GG25S2	410665	A.9	G708R2	444722	A.12
GT04K2	444726	A.9	G710R2	444723	A.12
GT07K2	444727	A.9	G713R2	444724	A.12
GT08K2	444728	A.9	G716R2	444725	A.12
GT10K2	444729	A.9	GJ04S2	408610	A.12
GT13K2	444730	A.9	GJ07S2	408614	A.12
GT16K2	444731	A.9	GJ08S2	408618	A.12
GG04N2	408376	A.9	GJ10S2	408625	A.12
GG07N2	408396	A.9	GJ13S2	408629	A.12
GG08N2	408436	A.9	GJ16S2	408637	A.12
GG10N2	408446	A.9	GJ20S2	408641	A.12
GG13N2	408456	A.9	GW04N2	408611	A.12
GG16N2	408496	A.9	GW07N2	408615	A.12
GG20N2	408516	A.9	GW08N2	408619	A.12
GG25N2	408529	A.9	GW10N2	408626	A.12
GG32N2	408548	A.9	GW13N2	408630	A.12
GG40N2	408568	A.9	GW16N2	408638	A.12
GG25F2	410668	A.9	GW20N2	408642	A.12
GG04H2	408372	A.9	GJ25N2	408680	A.12
GG07H2	408392	A.9	GJ32N2	408686	A.12
GG08H2	408432	A.9	GJ40N2	408692	A.12
GG10H2	408442	A.9	GW04M2	408710	A.12
GG13H2	408452	A.9	GW07M2	408714	A.12
GG16H2	408492	A.9	GW08M2	408653	A.12
GG20H2	408512	A.9	GW10M2	408657	A.12
GG04E2	408370	A.9	GW13M2	408666	A.12
GG07E2	408390	A.9	GW16M2	408670	A.12
GG08E2	408430	A.9	GW20M2	408674	A.12
GG10E2	408440	A.9	GW25M2	408682	A.12
GG13E2	408450	A.9	GW32M2	408688	A.12
GG16E2	408490	A.9	GW40M2	408694	A.12
GG20E2	408510	A.9	GJ32L2	408720	A.12
GG25H5	408526	A.9	GJ40L2	408722	A.12
GG32H5	408543	A.9	GJ50L2	408724	A.12
GG40H5	408563	A.9	GJ64L2	408726	A.12
GG04M2	408374	A.10	G704R2	444760	A.12
GG07M2	408394	A.10	G707R2	444761	A.12
GG08M2	408434	A.10	G708R2	444762	A.12
GG10M2	408444	A.10	G710R2	444763	A.12
GG13M2	408454	A.10	G713R2	444764	A.12
GG16M2	408494	A.10	G716R2	444765	A.12
GG20M2	408514	A.10	GW25F2	410689	A.12



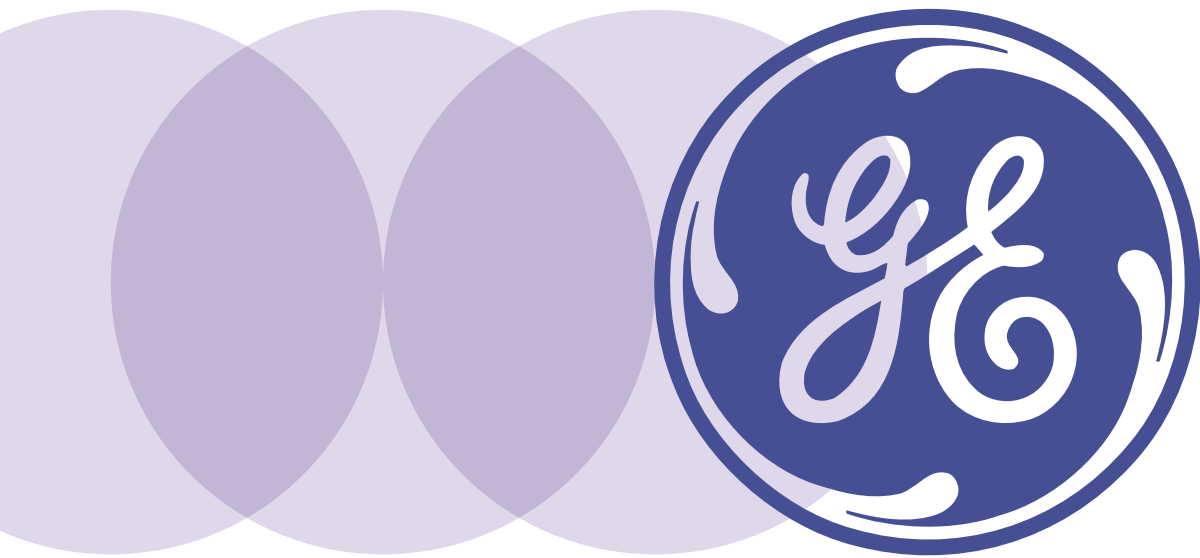

**Electronic trip units**

- B.2 Electronic trip units layout and main menu
- B.3 Overload protection LT-C and LTD
- B.4 Overload protection LT-F and LTD
- B.5 LT-inverse, very inverse and extremely inverse protection
- B.6 Table indicating available Long Time settings
- B.7 Short-circuit protection ST and STDB
- B.8 Short-circuit protection ST and I<sup>2</sup>T slope
- B.9 Short-circuit protection; instantaneous (I)
- B.11 Short-circuit protection temporary reduced I (RELT)
- B.12 Setting limitations of short-circuit devices - Short-circuit protection: HSIOC, MCR
- B.13 Ground fault protection: GF and GFD (Residual type)
- B.14 Ground fault protection: GF and I<sup>2</sup>t slope
- B.15 Ground fault protection
- B.16 Zone selective interlock, load shedding and trip indication
- B.17 Measurement functions and power supplies
- B.18 Protective relaying functions; relay and trip unit inputs wave form capture option
- B.19 Communications neutral protection, reset choice rating plug and test kit
- B.20 Overview of GT electronic trip unit functionality

The breaker

Order codes

**Electronic trip units**

**Time current curves (cold state)**

- B.21 LT protection device
- B.22 LT protection device
- B.23 LT and ST protection device
- B.24 ST protection device
- B.26 ST and I protection device
- B.27 HSIOC and GF protection device
- B.28 GF protection device
- B.29 Terminology
- B.30 Example of full time current curve

Breaker accessories

Application guide

Wiring diagrams

Dimensions

Numerical index

Intro

A

B

C

D

E

F

X



## Electronic trip units layout and main menu



### State of the art electronic trip unit

All EntelliGuard power circuit breakers are equipped with a digital electronic trip unit, available in four basic versions E, S, N and H. Each has a common design that comes with a screen providing an ammeter and allowing a simple and accurate menu driven adjustment of the breaker parameters across a broad current range.

All functionality is menu driven accessed by using 4 setting and one enter key thus allowing a fast and accurate setting of the device. These have the following functionality:

- ↑ UP: scroll up, increment value
- ↓ DOWN: scroll down, decrement value
- NEXT function, next page
- ← PREVIOUS function, previous page
- ↵ SAVE setting into memory

After inserting the universal rating plug, the device can be adjusted and the installed options set. In situations where the installation is not yet connected to the power supply, the use of the separately available TESTER with Power Pack is advised (Cat No. GTUTK20).

During normal operation the trip unit is powered either from current flow in the circuit breaker's internal current transformers or from an external DC supply. When neither of these sources is available it is still possible to review and modify settings or view events in the trip unit using power from the internal battery. Depressing any key on the face of the trip unit powers the unit from its internal battery. Battery power is maintained for 20 seconds after the last key is pressed. All normal setup, meter, and status functions can be performed with battery power. In Power On situations the trip unit display is only functional when the breaker is carrying at least 20% of its nominal current value (Single phase).

### SET UP MENU

To enter this option begin the process by pressing the UP or DOWN key until SETUP is selected on the screen. Pressing the NEXT or PREVIOUS key allows one to enter the setup mode. After selecting this mode, all functions can be chosen by depressing the NEXT or PREVIOUS key. Within the setup menu all breaker protection values, trip unit parameters, relaying functions in and outputs, communication and trip unit access codes are set. Each EntelliGuard electronic trip units provides long-time over-current protection (LT), long-time delay (LTD) and some form of short-circuit over-current protection (ST and/or I, H, RELT). Depending on the chosen trip unit tier or type and the selected options a, host of other protection, metering relaying functions and a wave form capture option are available. In the following pages each of these functions are described in detail. A set of tabs placed below each description indicate in which trip unit tier the described function is present.

### METER

To enter this option begin the process by pressing the UP or DOWN key until METER is selected on the screen. Pressing the NEXT or PREVIOUS key allows one to view various groups of measurements as current, voltage, real, apparent and reactive power for the electrical system protected by the device. Both currents and voltages are computed as true rms values. All EntelliGuard trip units are equipped with an Ammeter. The full measurement package is offered in the GT-N and GT-H variants. The ammeter and other measurement options are only available when the trip unit is powered by the distribution system, the internal trip unit batteries or the external Test/Battery pack. The full measurement package requires the use of a separately available 3 phase instrument transformer and Power Conditioner pack.

### STATUS

To enter this option begin the process by pressing the UP or DOWN key until STATUS is selected on the screen. The status option indicates the present status and settings of the trip unit and circuit breaker.

### EVENTS

To enter this option begin the process by pressing the UP or DOWN key until EVENTS is selected on the screen. Pressing the NEXT or PREVIOUS key allows one to access events. Here a total of 10 events with data as event type and event magnitude are stored. The connection of a 24V DC auxiliary supply to the trip unit will expand this option to include a time stamp of each event.

Tripping events as LT, ST, I GF, overload trip imminent (pre alarm) or any other, release or relay trip event are visualized with the associated levels. It is possible to clear this so called "trip register" locally. If the trip unit is equipped with this option, a history of up to 256 tripping occurrences with data as event type and event magnitude are stored.

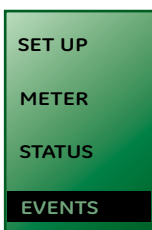
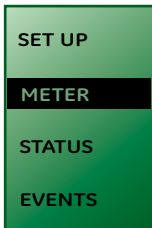
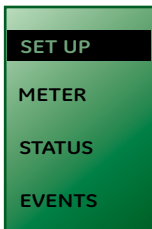

## Overload protection LT-C and LTD

### Overload (LT-C) protection

The EntelliGuard electronic trip has an extremely accurate and easy to set overload or Long Time (LT-C) Protection. It is designed to pick up overloads that exceed 112% of the set value within two hours with a tolerance of 10%<sup>[1]</sup>. The available 66 different current adjustments (see page B.4) result in an extremely broad setting range of 0.2 to 1 times the chosen breaker rating (In).

The LT-C type is designed to be used in association with down- and upstream circuit breakers and has a so called I<sup>2</sup>t shape producing a curve form similar to standard industrial thermal magnetic protection devices.

The time-current protection curve depicted here is drawn in cold state. A thermal model in the device corrects for the heating of the connected lines and equipment. This device continues to track cooling even when disconnected in 'thermal memory'. The reconnection of power to over-heated lines and equipment thus being prevented. Thermal memory tracks events after power disconnection for up to 12 minutes.

In order to allow an accurate adjustment to the thermal properties of the protected equipment and to finely match the curve with those of upstream and downstream devices 22 LTD time bands are available.

The table indicates the minimum delay time and maximum total interruption times for 3 frequently used reference points on the curve of each band.

The graph portrays the LT behaviour for the time-current bands C-4, C- 8, C-13 and C-22.

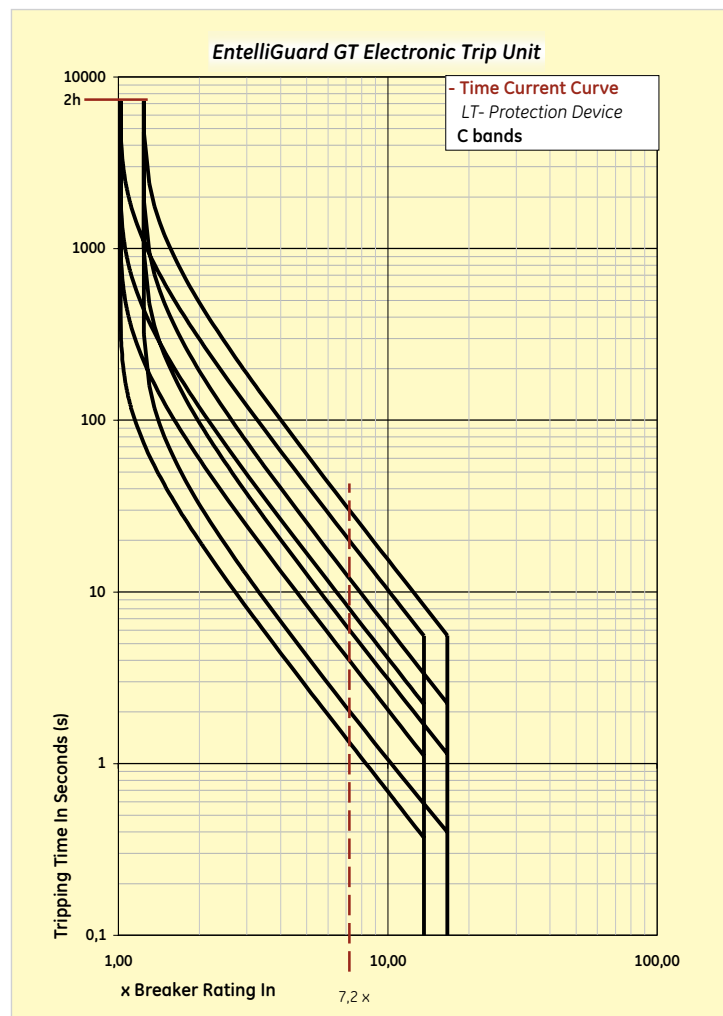
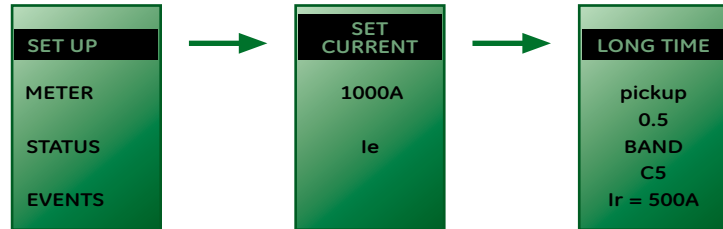

Overload tripping times at indicated overload levels per selected LTD band, in seconds

x Ir	Cmin	C-2	C-3	C-4	C-5	C-6	C-7	C-8	C-9	C-10	C-11	C-12	C-13	C-14	C-15	C-16	C-17	C-18	C-19	C-20	C-21	Cmax	
1.5	Max.	7.8	23.4	46.7	62.3	93.4	125	156	187	218	249	280	311	374	436	498	560	623	685	747	810	872	934
	Min.	4.0	12.0	24.0	32.0	48.0	64.1	80.1	96.1	112	128	144	160	192	224	256	288	320	352	384	416	448	480
3	Max.	1.3	3.86	7.73	10.3	15.5	20.6	25.8	30.9	36.1	41.2	46.4	51.5	61.8	72.1	82.4	92.7	103	113	124	134	144	155
	Min.	0.80	2.41	4.82	6.43	9.64	12.9	16.1	19.3	22.5	25.7	28.9	32.1	38.6	45.0	51.4	57.8	64.3	70.7	77.1	83.6	90.0	96.4
7.2	Max.	0.21	0.62	1.24	1.66	2.49	3.32	4.15	4.98	5.81	6.64	7.47	8.30	9.96	11.6	13.3	14.9	16.6	18.3	19.9	21.6	23.2	24.9
	Min.	0.13	0.40	0.81	1.07	1.61	2.15	2.69	3.22	3.76	4.30	4.83	5.37	6.45	7.52	8.60	9.67	10.7	11.8	12.9	14.0	15.0	16.1
Motor protection class to IEC 947-4		10b						10				20				30				40			

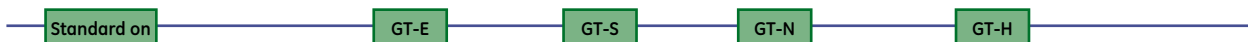

[1] Meeting the requirements of IEC 90647-2 and IEC 90647-4



## Overload protection LT-F and LTD

### Overload (LT-F) protection

A second type of overload protection is available. Designed to pick up overloads that exceed 112% of the set value within two hours, with a tolerance of 10%<sup>(1)</sup>, it has the same 66 different current adjustments as the standard type thus offering an extremely broad setting range of 0.2 to 1 times the chosen breaker rating.

The time-current protection curve depicted here is drawn in cold state. A thermal model in the device corrects for the heating of the connected lines and equipment. This device continues to track cooling even when disconnected in 'thermal memory'.

The reconnection of power to over-heated lines and equipment thus being prevented. Thermal memory tracks events after power disconnection for up to 12 minutes.

The LT-F device is designed to be used in association with down- and upstream Fuses and produces a curve form similar to those of standard industrial fuses. A total of 22 LTD time bands are available, thus extending the total number of bands to 44. The table indicates the minimum delay time and maximum total interruption times for 3 frequently used reference points on the curve of each band.

The graph portrays the LT behaviour for the time-current bands F-4, F-9, F-15 and F-22.

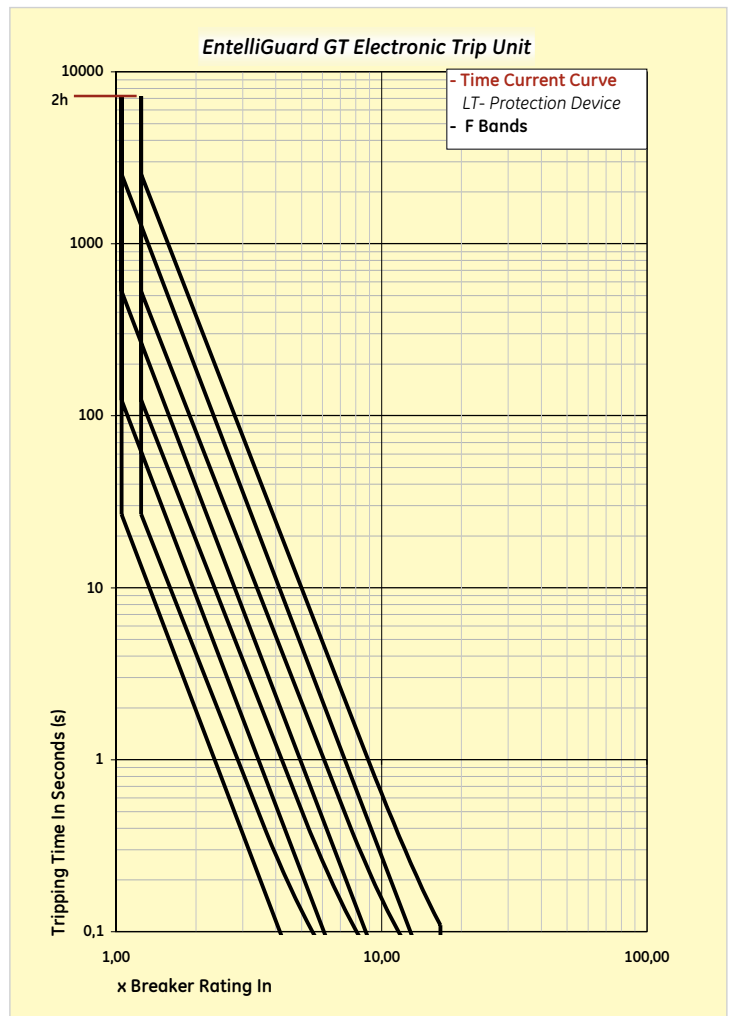
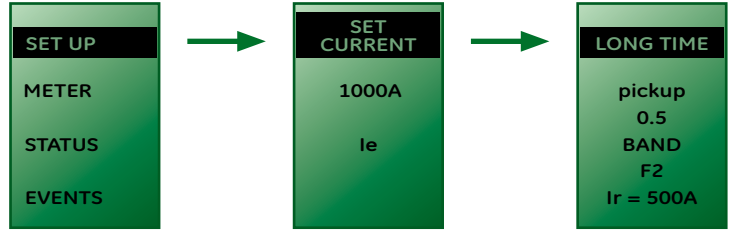

Overload tripping times at indicated overload levels per selected LTD band, in seconds

x Ir	Fmin	F-2	F-3	F-4	F-5	F-6	F-7	F-8	F-9	F-10	F-11	F-12	F-13	F-14	F-15	F-16	F-17	F-18	F-19	F-20	F-21	Fmax	
1.5	Max.	1.44	4.19	7.62	11.9	17.2	23.9	32.3	42.8	56	72	93	118	150	190	239	302	380	477	600	752	942	1153
	Min.	0.64	1.87	3.39	5.30	7.67	10.7	14.4	19.0	25	32	41	53	67	85	107	135	169	213	267	335	419	514
3	Max.	0.09	0.26	0.48	0.74	1.08	1.50	2.01	2.67	3.49	4.51	5.80	7.39	9.39	11.9	15.0	18.9	23.8	29.9	37.5	47.0	58.9	72.1
	Min.	0.04	0.12	0.21	0.33	0.48	0.67	0.90	1.19	1.55	2.01	2.57	3.29	4.18	5.29	6.68	8.41	10.6	13.3	16.7	20.9	26.2	32.1
7.2	Max.				0.03	0.05	0.06	0.08	0.11	0.14	0.18	0.22	0.28	0.36	0.45	0.57	0.72	0.90	1.13	1.42	1.78	2.18	
	Min.				0.01	0.02	0.03	0.04	0.05	0.06	0.08	0.10	0.13	0.16	0.20	0.25	0.32	0.40	0.50	0.63	0.79	1.03	



(1) Meeting the requirements of IEC 90647-2 and IEC 90647-4



## LT-Inverse, very inverse and extremely inverse protection

### Overload (LT-inverse) protection

The EntelliGuard electronic trip has an extremely accurate and easy to set overload or Long Time (LT-inverse) protection. It is designed to pick up overloads that exceed 112% of the set value within two hours with a tolerance of 10%<sup>(1)</sup>. The available 66 different current adjustments (see page B.6) result in an extremely broad setting range of 0.2 to 1 times the chosen breaker rating (In). The LT-inverses band types are designed to be used in association with down- and upstream devices meeting the industrial IEC 60255 standard. The time-current protection curves depicted here are drawn in cold state. A thermal model in the device corrects for the heating of the connected lines and equipment. This device continues to track cooling even when disconnected in 'thermal memory'. The reconnection of power to over-heated lines and equipment thus being prevented. Thermal memory tracks events after power disconnection for up to 12 minutes. In order to allow an accurate adjustment to the thermal properties of the protected equipment and to finely match the curve with those of upstream & downstream devices 13 LTD time bands are available in three standardised shapes (inverse, very inverse & extremely inverse). The tables indicates the minimum delay time and maximum total interruption times for 3 frequently used reference points on the curve of each band. The graph portrays the LT behaviour for the inverse, very inverse & extremely inverse band shapes.

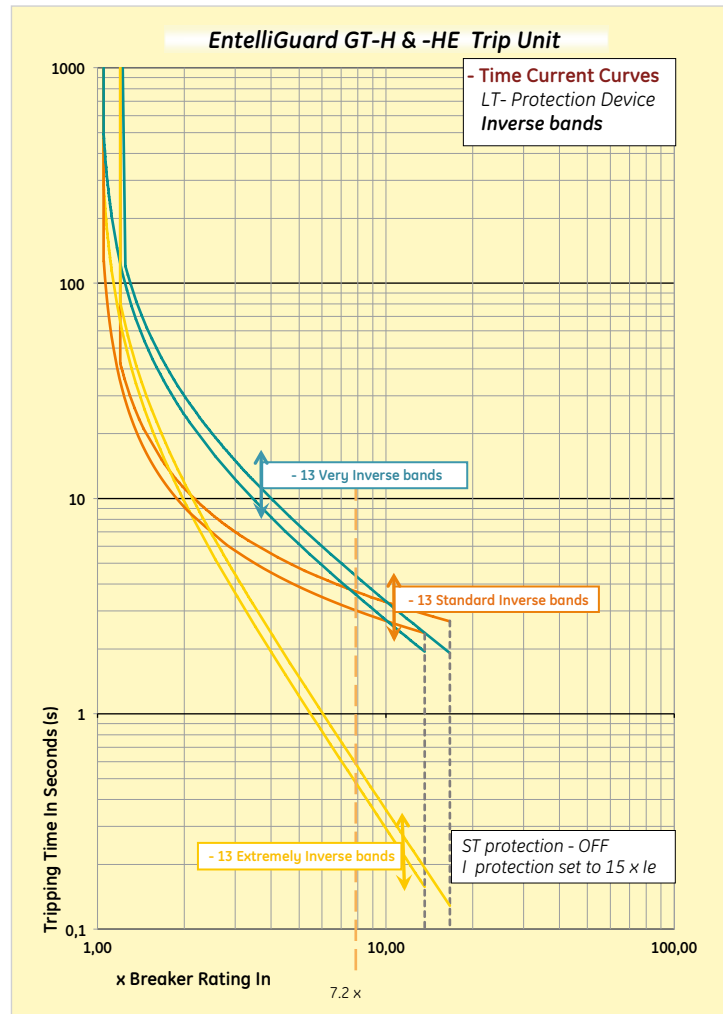

#### Inverse curves

x Ir	L-0.5	L-1	L-2	L-3	L-4	L-5	L-6	L-7	L-8	L-9	L-10	L-15	L-20	
1.5	Max.	1.02	2.05	4.09	6.14	8.18	10.23	12.27	14.32	16.36	18.41	20.45	30.7	40.9
	Min.	0.76	1.51	3.03	4.54	6.06	7.57	9.09	10.60	12.12	13.63	15.15	22.72	30.3
3	Max.	0.32	0.64	1.28	1.91	2.55	3.19	3.83	4.47	5.11	5.74	6.38	9.6	12.8
	Min.	0.31	0.63	1.26	1.88	2.51	3.14	3.77	4.40	5.02	5.65	6.28	9.42	12.6
7.2	Max.	0.18	0.37	0.73	1.10	1.47	1.83	2.20	2.56	2.93	3.30	3.66	5.49	7.33
	Min.	0.17	0.33	0.66	1.00	1.33	1.66	1.99	2.33	2.66	2.99	3.32	4.99	6.65

#### Very inverse curves

x Ir	L-0.5	L-1	L-2	L-3	L-4	L-5	L-6	L-7	L-8	L-9	L-10	L-15	L-20	
1.5	Max.	1.69	3.38	6.75	10.13	13.50	16.88	20.25	23.63	27.00	30.38	33.75	50.6	67.5
	Min.	1.13	2.25	4.50	6.75	9.00	11.25	13.50	15.75	18.00	20.25	22.50	33.75	45.0
3	Max.	0.36	0.71	1.42	2.13	2.84	3.55	4.26	4.97	5.68	6.39	7.11	10.7	14.2
	Min.	0.32	0.64	1.29	1.93	2.57	3.21	3.84	4.48	5.12	5.76	6.40	9.6	12.8
7.2	Max.	0.11	0.22	0.44	0.66	0.89	1.11	1.33	1.55	1.77	1.99	2.21	3.32	4.43
	Min.	0.11	0.21	0.43	0.64	0.86	1.07	1.29	1.50	1.71	1.93	2.14	3.21	4.29

#### Extremely inverse curves

x Ir	L-0.5	L-1	L-2	L-3	L-4	L-5	L-6	L-7	L-8	L-9	L-10	L-15	L-20	
1.5	Max.	4.23	8.46	16.92	25.38	33.85	42.31	50.77	59.23	67.69	76.15	84.62	126.9	169.2
	Min.	2.50	5.00	10.00	15.00	20.00	25.00	30.00	35.00	40.00	45.00	50.00	75.00	100.0
3	Max.	0.56	1.13	2.26	3.39	4.52	5.65	6.78	7.91	9.04	10.17	11.30	16.9	22.6
	Min.	0.44	0.88	1.76	2.64	3.52	4.40	5.27	6.15	7.03	7.91	8.79	13.19	17.6
7.2	Max.	0.09	0.17	0.35	0.52	0.70	0.87	1.04	1.22	1.39	1.56	1.74	2.61	3.48
	Min.	0.07	0.14	0.28	0.42	0.56	0.71	0.85	0.99	1.13	1.27	1.41	2.12	2.82

Standard on

GT-H

(1) Meeting the requirements of IEC 90647-2 and IEC 90647-4



Table indicating available Long Time settings

Per chosen breaker rating (In) 66 current values (Ir) can be set

Electronic trip units

Breaker rating	Multip.	Primary setting Ie values in Amps					
		Secondary setting Ir values in Amps					
400	1	400	390	385	380	180	160
	0.95	380	371	366	361	171	152
	0.9	360	351	347	342	162	144
	0.85	340	332	327	323	153	136
	0.8	320	312	308	304	144	128
	0.75	300	293	289	285	135	120
	0.7	280	273	270	266	126	112
	0.65	260	254	250	247	117	104
	0.6	240	234	231	228	108	96
	0.55	220	215	212	209	99	88
630	0.5	200	195	193	190	90	80
	1	630	615	610	605	280	250
	0.95	599	584	580	575	266	238
	0.9	567	554	549	545	252	225
	0.85	536	523	519	514	238	213
	0.8	504	492	488	484	224	200
	0.75	473	461	458	454	210	188
	0.7	441	431	427	424	196	175
	0.65	410	400	397	393	182	163
	0.6	378	369	366	363	168	150
800	0.55	347	338	336	333	154	138
	0.5	315	308	305	303	140	125
	1	800	784	776	768	350	315
	0.95	760	745	737	730	333	299
	0.9	720	706	698	691	315	284
	0.85	680	666	660	653	298	268
	0.8	640	627	621	614	280	252
	0.75	600	588	582	576	263	236
	0.7	560	549	543	538	245	221
	0.65	520	510	504	499	228	205
1000	0.6	480	470	466	461	210	189
	0.55	440	431	427	422	193	173
	0.5	400	392	388	384	175	158
	1	1000	980	970	960	450	400
	0.95	950	931	922	912	428	380
	0.9	900	882	873	864	405	360
	0.85	850	833	825	816	383	340
	0.8	800	784	776	768	360	320
	0.75	750	735	728	720	338	300
	0.7	700	686	679	672	315	280
1250	0.65	650	637	631	624	293	260
	0.6	600	588	582	576	270	240
	0.55	550	539	534	528	248	220
	0.5	500	490	485	480	225	200
	1	1250	1225	1210	1196	560	500
	0.95	1188	1164	1150	1136	532	475
	0.9	1125	1103	1089	1076	504	450
	0.85	1063	1041	1029	1017	476	425
	0.8	1000	980	968	957	448	400
	0.75	938	919	908	897	420	375
1600	0.7	875	858	847	837	392	350
	0.65	813	796	787	777	364	325
	0.6	750	735	726	718	336	300
	0.55	688	674	666	658	308	275
	0.5	625	613	605	598	280	250
	1	1600	1568	1552	1536	720	630
	0.95	1520	1490	1474	1459	684	599
	0.9	1440	1411	1397	1382	648	567
	0.85	1360	1333	1319	1306	612	536
	0.8	1280	1254	1242	1229	576	504
630	0.75	1200	1176	1164	1152	540	473
	0.7	1120	1098	1086	1075	504	441
	0.65	1040	1019	1009	998	468	410
	0.6	960	941	931	922	432	378
	0.55	880	862	854	845	396	347
	0.5	800	784	776	768	360	315

Breaker rating	Multip.	Primary setting Ie values in Amps					
		Secondary setting Ir values in Amps					
2000	1	2000	1960	1940	1920	900	800
	0.95	1900	1862	1843	1824	855	760
	0.9	1800	1764	1746	1728	810	720
	0.85	1700	1666	1649	1632	765	680
	0.8	1600	1568	1552	1536	720	640
	0.75	1500	1470	1455	1440	675	600
	0.7	1400	1372	1358	1344	630	560
	0.65	1300	1274	1261	1248	585	520
	0.6	1200	1176	1164	1152	540	480
	0.55	1100	1078	1067	1056	495	440
2500	0.5	1000	980	970	960	450	400
	1	2500	2450	2425	2400	1125	1000
	0.95	2375	2328	2304	2280	1069	950
	0.9	2250	2205	2183	2160	1013	900
	0.85	2125	2083	2061	2040	956	850
	0.8	2000	1960	1940	1920	900	800
	0.75	1875	1838	1819	1800	844	750
	0.7	1750	1715	1698	1680	788	700
	0.65	1625	1593	1576	1560	731	650
	0.6	1500	1470	1455	1440	675	600
3200	0.55	1375	1348	1334	1320	619	550
	0.5	1250	1225	1213	1200	563	500
	1	3200	3136	3104	3072	1440	1280
	0.95	3040	2979	2949	2918	1368	1216
	0.9	2880	2822	2794	2765	1296	1152
	0.85	2720	2666	2638	2611	1224	1088
	0.8	2560	2509	2483	2458	1152	1024
	0.75	2400	2352	2328	2304	1080	960
	0.7	2240	2195	2173	2150	1008	896
	0.65	2080	2038	2018	1997	936	832
4000	0.6	1920	1882	1862	1843	864	768
	0.55	1760	1725	1707	1690	792	704
	0.5	1600	1568	1552	1536	720	640
	1	4000	3920	3880	3840	1800	1600
	0.95	3800	3724	3686	3648	1710	1520
	0.9	3600	3528	3492	3456	1620	1440
	0.85	3400	3332	3298	3264	1530	1360
	0.8	3200	3136	3104	3072	1440	1280
	0.75	3000	2940	2910	2880	1350	1200
	0.7	2800	2744	2716	2688	1260	1120
5000	0.65	2600	2548	2522	2496	1170	1040
	0.6	2400	2352	2328	2304	1080	960
	0.55	2200	2156	2134	2112	990	880
	0.5	2000	1960	1940	1920	900	800
	1	5000	4900	4850	4800	2250	2000
	0.95	4750	4655	4608	4560	2138	1900
	0.9	4500	4410	4365	4320	2025	1800
	0.85	4250	4165	4123	4080	1913	1700
	0.8	4000	3920	3880	3840	1800	1600
	0.75	3750	3675	3638	3600	1688	1500
6400	0.7	3500	3430	3395	3360	1575	1400
	0.65	3250	3185	3153	3120	1463	1300
	0.6	3000	2940	2910	2880	1350	1200
	0.55	2750	2695	2668	2640	1238	1100
	0.5	2500	2450	2425	2400	1125	1000
	1	6400	6272	6208	6144	2880	2560
	0.95	6080	5958	5898	5837	2736	2432
	0.9	5760	5645	5587	5530	2592	2304
	0.85	5440	5331	5277	5222	2448	2176
	0.8	5120	5018	4966	4915	2304	2048
630	0.75	4800	4704	4656	4608	2160	1920
	0.7	4480	4390	4346	4301	2016	1792
	0.65	4160	4077	4035	3994	1872	1664
	0.6	3840	3763	3725	3686	1728	1536
	0.55	3520	3450	3414	3379	1584	1408
	0.5	3200	3136	3104	3072	1440	1280





## Short-circuit protection ST and STDB

### Overcurrent protection against short-circuit: ST, STDB

The EntelliGuard electronic trip unit and breaker combination can be equipped with a number of different Short-circuit protection devices each with their own distinctive properties and field of application.

The timed short-circuit protection device is designed to offer selectivity over a defined current range and offers a unique combination of multiple time bands and current settings.

To allow selectivity with a wide range of different downstream devices whilst not unnecessarily sacrificing clearing time, 17 different time bands are available. The device has an adjustment range of 1.5 to 12<sup>(1)</sup> ( $\pm 10\%$ ) times the chosen Long Time current value (I<sub>r</sub>) in steps of 0.5 (pick up setting).

The graph indicates 6 of the available 17 time bands across the full adjustment range. The table contains the minimum delay time and the maximum total interruption times for all time band settings.

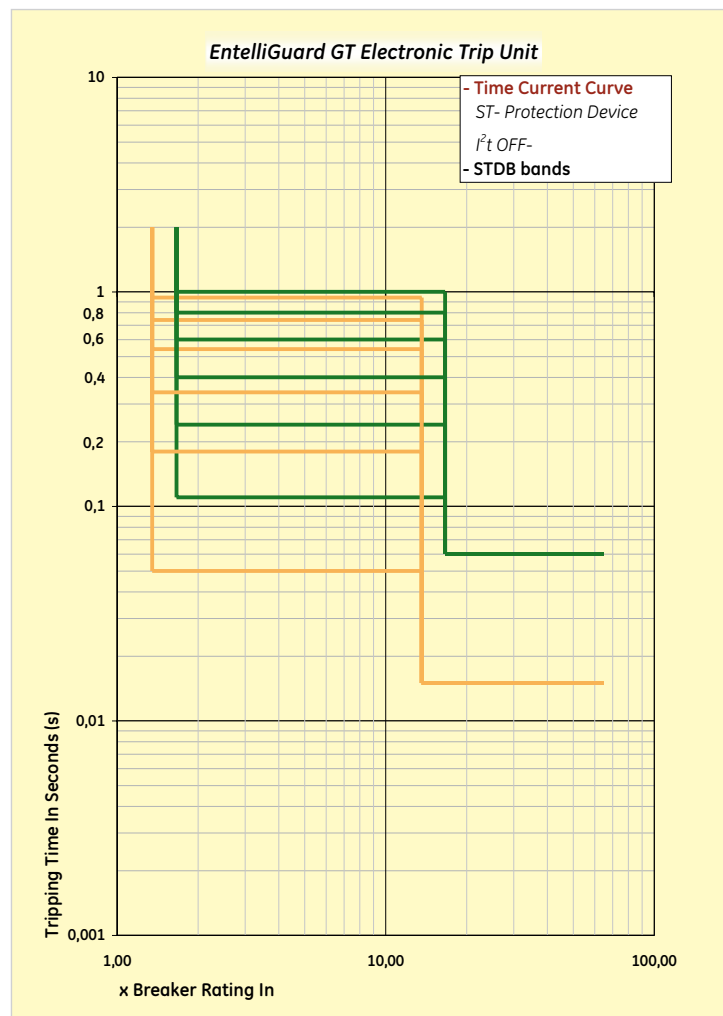
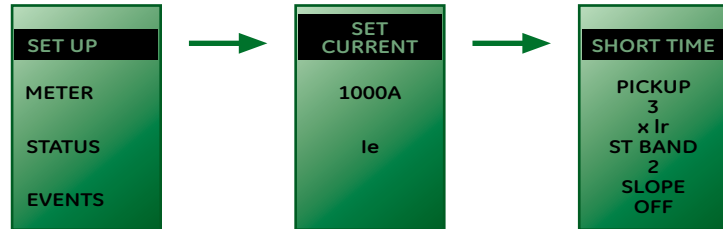

Short time tripping times at indicated levels per selected STDB band - I<sup>2</sup>t OFF, in milliseconds

	x I <sub>r</sub>	Min	2	3	4	5	6	7	8	9	10	11	12	13	14	15	16	Max
1.5 x ±10%	Max	90	100	110	120	170	190	240	270	300	340	400	450	600	700	800	900	1000
	Min	30	40	50	60	110	130	180	210	240	280	340	390	540	640	740	840	940
12 x ±10%	Max	90	100	110	120	170	190	240	270	300	340	400	450	600	700	800	900	1000
	Min	30	40	50	60	110	130	180	210	240	280	340	390	540	640	740	840	940

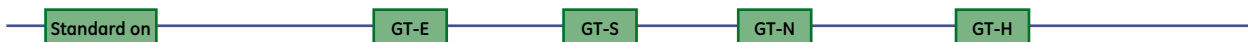

(1) I<sub>s</sub> is limited to lower values in certain cases, please refer to page B.11



## Short-circuit protection ST and I<sup>2</sup>T slope

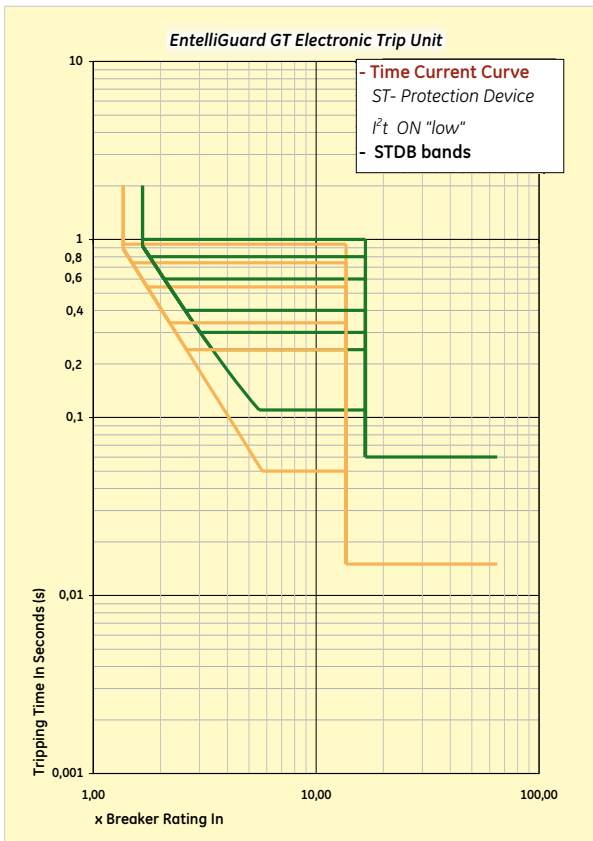

### Timed short-circuit (ST) protection I<sup>2</sup>T bands (slope)<sup>(1)</sup>

The ST device can also be set to an I<sup>2</sup>T slope value. The available multiple I<sup>2</sup>T slopes are normally used to achieve selectivity with downstream fuses or to improve selectivity with downstream circuit breakers.

The device has an adjustment range of 1.5 to 12<sup>(1)</sup> (±10%) times the chosen Long Time current value (I<sub>r</sub>) in steps of 0.5 (pick up setting) and 17 time bands.

The three graphs depict the available I<sup>2</sup>T slopes (low, med. or high) and their intersection with a selection of the available 17 time bands across the full adjustment range.

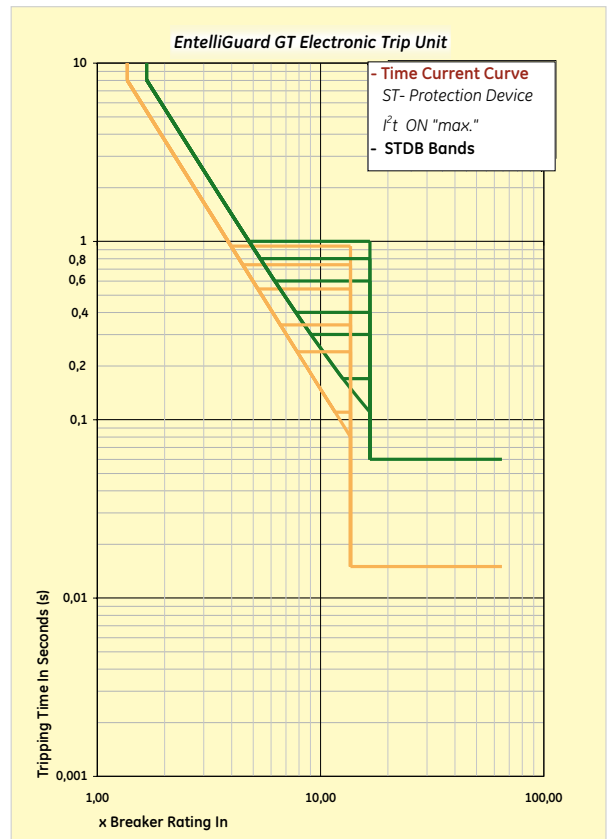
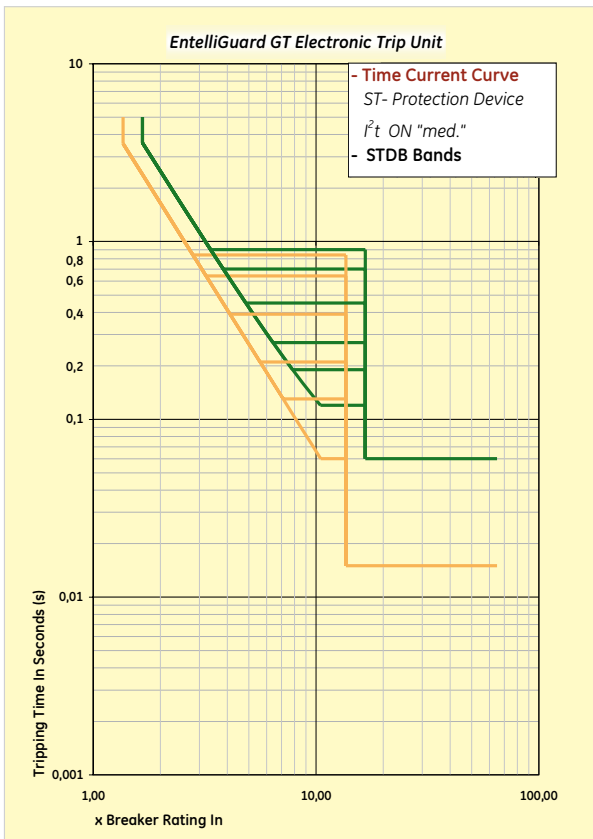
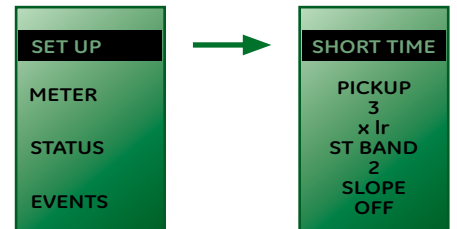

Standard on

GT-E

GT-S

GT-N

GT-H

(1) When the LT fuse band option is selected (22 F bands) the I<sup>2</sup>T slope functions of this device are disabled



## Short-circuit protection; instantaneous (I)

### Instantaneous short-circuit (I) protection

A user settable device that allows a high speed fault interruption at a pre-determined current level. This device can be used with the short time delayed (ST) short-circuit protection device or as replacement thereof. The device has a current adjustment of 2 to 15 ( $\pm 10\%$ ) times the chosen primary current value ( $I_e$ ) in steps of 0.5. The device can also be switched OFF. On breakers with a rating of more than 4000A the maximum setting of 15 x is in some cases limited to a lower value due to the breaker current rating and its short-circuit withstand value (see page B.12). The instantaneous tripping system used in the EntelliGuard electronic trip unit has a unique programming feature that waits for the downstream device to trip before reacting to an overcurrent fault. This providing the user with a unique combination of **Speed** and **Selectivity**.

*The graph indicates the maximum interruption time and non tripping time across the full current setting band and the transition to the HSIOC protection device (see page B.12).*

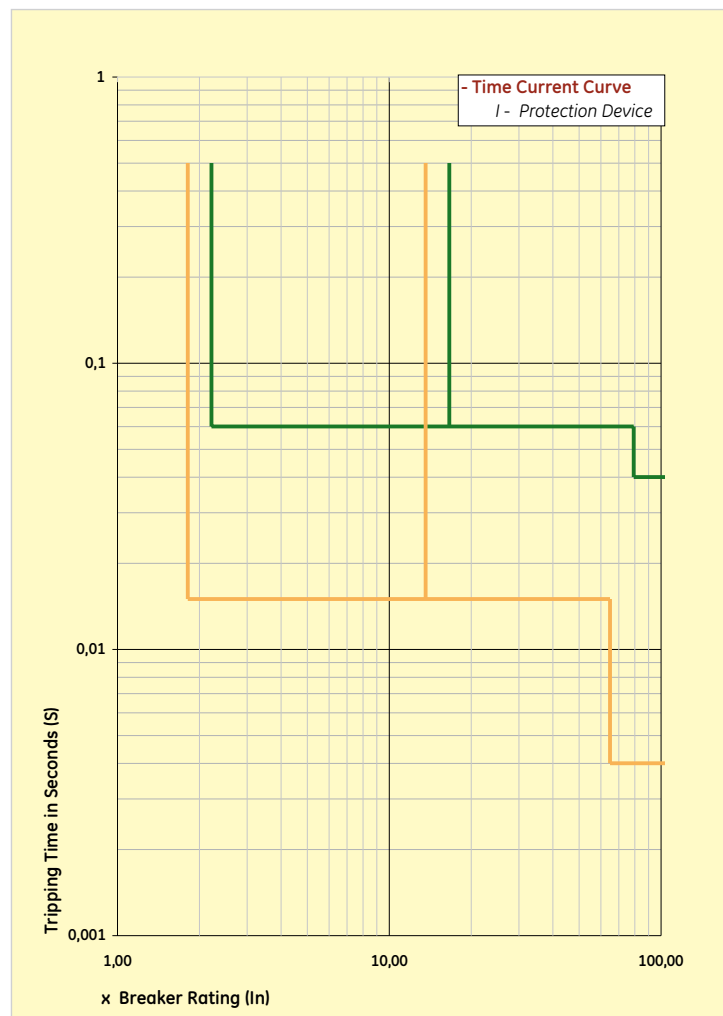
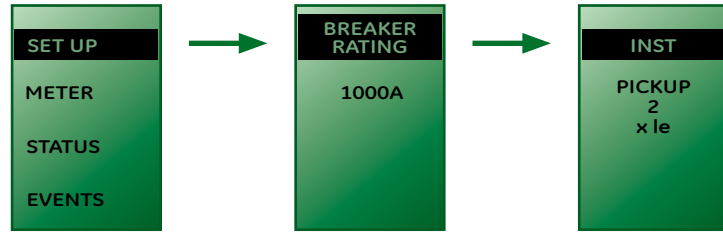

- Intro
- A
- B**
- C
- D
- E
- F
- X

## Short-circuit protection; instantaneous (I ext.)

### Extended range instantaneous protection

Derived from, and based on the same principles as the standard Instantaneous protection but with and extended current adjustment range.

This high-level instantaneous device extends the standard range from 2 - 15 to 2 - 30 ( $\pm 10\%$ ) times the chosen primary current value ( $I_e$ ). Until  $15 \times I_e$  in steps of 0.5 and for the extended setting (above  $15 \times I_e$ ) in steps of 1. The device can also be switched OFF.

On breakers with a rating of more than 2000A the maximum setting of  $30 \times$  is in some cases limited to a lower value due to the breaker current rating and its short-circuit withstand value (see page B.12).

As with the standard Instantaneous tripping system the device has a unique programming feature that waits for the downstream device to trip before reacting to an overcurrent fault. This providing the user with a unique combination of **Speed** and **Selectivity**.

*The graph indicates the maximum interruption time and non tripping time across the full current setting band and the transition to the HSIOC protection device (see page B.12).*

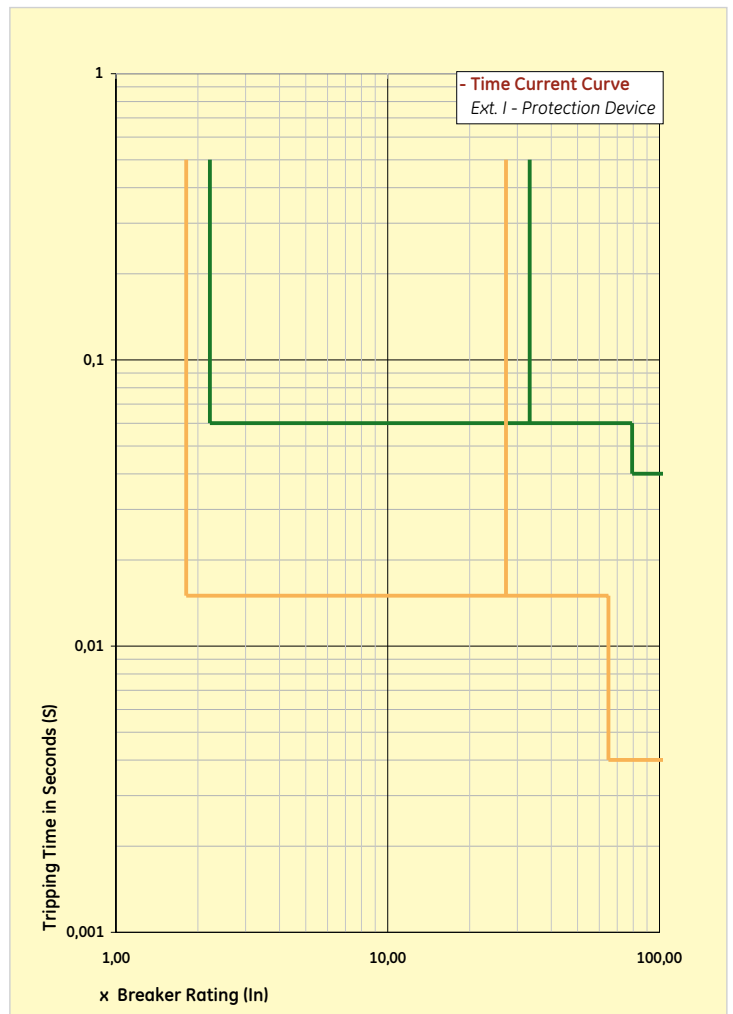
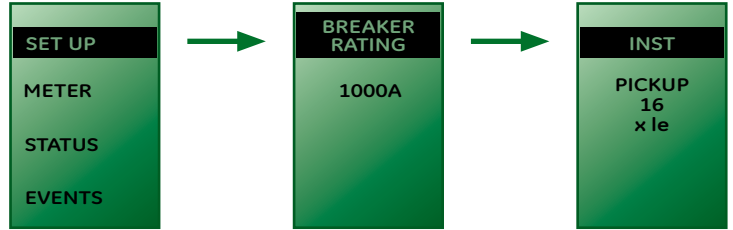

Optional on

GT-S

GT-N

GT-H

## Short-circuit protection temporary reduced I (RELT)

### Temporary reduced setting of instantaneous short-circuit device (RELT)

When a short-circuit event takes place, large amount of electrical energy is released that can be hazardous to users in the direct vicinity of such an occurrence.

Reducing the levels of arc flash incident energy during such events is possible by limiting both the events current level and time span.

The EntelliGuard G electronic trip unit can be equipped with a device that temporarily limits both the events current level and time span: **RELT**

The RELT device can be turned ON by accessing input one of the trip unit<sup>(1)</sup>. When the device is switched ON relay output one<sup>(1)</sup> changes position and reverts to it's standard position when RELT is OFF.

The RELT device can be adjusted from 1.5 to 15 (±10%) times the chosen primary current value (Ie) in steps of 0.5 (pick up setting). The device will trip the breaker within 50 milliseconds.

An optional accessory, GTURSK, can be ordered which has a LED illuminated 3 position selector switch. This accessory can be mounted on the front of switchgear and wired to the secondary disconnect of the breaker.

A user then has the ability to select either ON, OFF or TEST.

- ON** Activates RELT, and selector switch is illuminated indicating that RELT is active
- OFF** RELT is inactive and selector switch is not illuminated
- TEST** RELT is not activated, but selector switch is illuminated to indicate positive connection

*The graph indicates the maximum interruption time and non tripping time across the full current setting band and the transition to the HSIOC protection device (see page B.12).*

*Information on how to set this device can be found in IEEE standard 1548.*

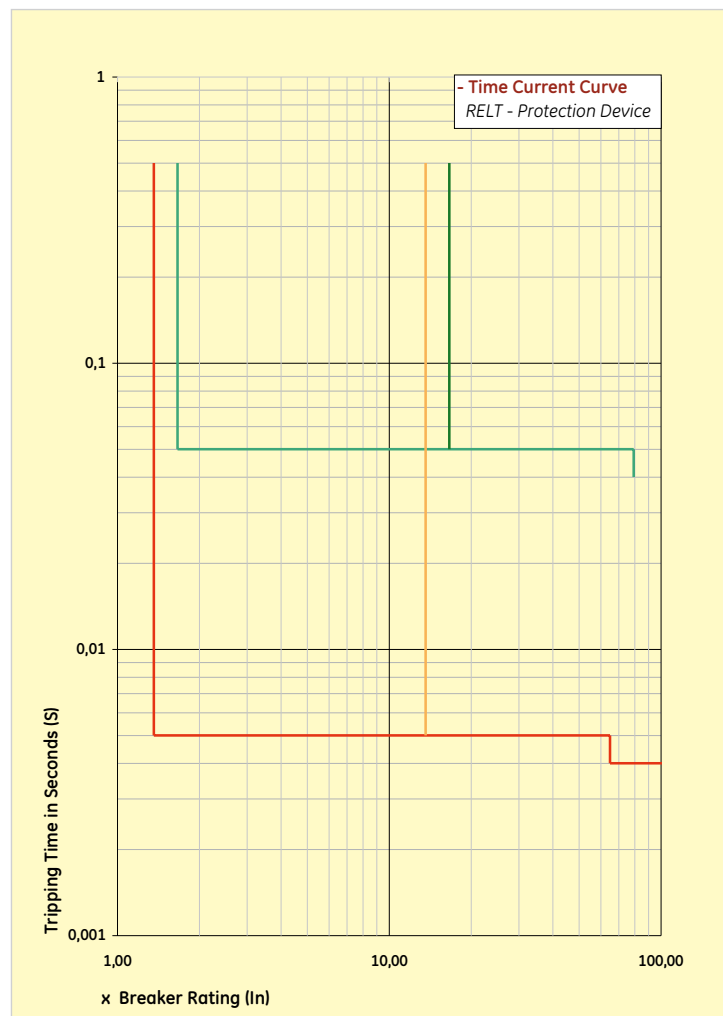
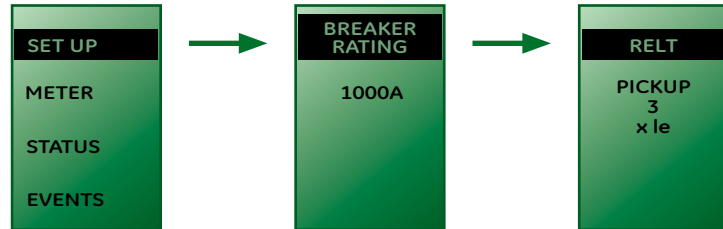

Standard on

GT-N

GT-H

(1) See section on electronic inputs and relay outputs on page B.18



## Setting limitations of short-circuit devices Short-circuit protection: HSIOC, MCR

### Setting limitations of short-circuit devices.

To prevent damage to the EntelliGuard breaker due to currents that exceed its design parameters, the maximum setting values of the ST & I devices are in some cases limited to a lower level.

These values are indicated in the adjacent table.

Breaker rating In	Primary setting current Ie	Breaker Icw rating				
		42kA	50kA	65kA	85kA	100kA
5000A	5000A				10x	10x
6400A	6400A				10x	10x
		Maximum ST setting (x Ie) <sup>(1)</sup>				
1600A	1600A	15x				
2000A	2000A		24x			
2500A	2500A			30x	30x	30x
3200A	3200A			25x	30x	30x
4000A	4000A			19x	25x	30x
4000A	4000A			15x	20x	24x
5000A	5000A				15x	19x
6400A	6400A				13x	15x

Breaker type is not available

### HSIOC protection device

To prevent very high level short-circuit currents causing damage to their electrical installation and their components EntelliGuard power circuit breaker are equipped with a HSIOC protection device.

This high-level short-circuit device is installed in all EntelliGuard breakers and is designed to trip the breaker at the specified Icw value of the device<sup>(3)</sup>. The device interrupts and thus limits the duration of these high level short-circuits to 40 milliseconds.

The HSIOC device is normally set at a value that is slightly higher than the specified 1 second Icw of the breaker in which it is installed. This to warranty selectivity at the specified 1 second level taking system tolerances into account<sup>(2)</sup>.

### Making current (MCR) protection device

If a breaker is closed onto a short-circuit current it is mandatory that the device interrupts before the electrical installation and its components incur any damage.

An MCR device is present in all EntelliGuard power circuit breakers<sup>(3)</sup> specifically designed to trip the breaker when closing onto a fault.

Overview of installed HSIOC devices in automatic types:	Set value (rms)
<b>Frame T</b>	
GT04R to GT16R	42000A
GT04K to GT16K	50000A
<b>Frame 1</b>	
GG25S	42000A
GG04S to GG25S	50000A
GG04N to GG20N	65000A
GG04H to GG20H	65000A
GG25F	65000A
<b>Frame 2</b>	
GG25N to GG40N	65000A
GH32N and GH40N	65000A
GG04E to GG20E	85000A
GG25H to GG40H	85000A
GH32H and GH40H	85000A
GH32M and GH40M	85000A
<b>Frame 3</b>	
GG32G to GG40G	100000A
GG40M to GG64M	100000A
GG40L to GG64L	100000A

Overview of installed MCR devices in automatic types:	Set value (rms)
<b>Frame T</b>	
GT04R to GT16R	32800A
GT04K to GT16K	32800A
<b>Frame 1</b>	
GG04S to GG20S	42000A
GG20S to GG25S	50000A
GG04N to GG20N	65000A
GG04H to GG20H	65000A
GG25F	65000A
<b>Frame 2</b>	
GG25N to GG40N	65000A
GH32N and GH40N	65000A
GG04E to GG20E	85000A
GG25H to GG40H	85000A
GH32H and GH40H	85000A
GH32M and GH40M	85000A
<b>Frame 3</b>	
GG32G to GG40G	100000A
GG40M to GG64M	100000A
GG40L to GG64L	100000A

Overview of installed MCR devices in non automatic types:	Set value (rms)
<b>Frame 1</b>	
GW04N to GW20N	65000A
GW25F	50000A
<b>Frame 2</b>	
GW04M to GW40M	85000A
GZ32H and GZ40H	85000A

Note: GJ & G7 non automatic types do not have MCR.

(1) If the short time device (ST) is turned OFF the highest instantaneous or extended instantaneous setting is reduced to 15 x Ie for all types ≤ 4000A and to 10 x Ie for the 5000 and 6400A types

(2) If the breaker is not equipped with an Instantaneous protection device (I or Hi) or in cases where device is set to off the HSIOC device current threshold is automatically reduced by 10%

(3) Only included in selected non automatic types



## Ground fault protection

### Ground fault protection (GFsum)

To protect an installation or a part thereof against indirect contact, protection devices can be used to automatically disconnect the power supply when a fault to earth is detected. The HD384 installation standard requires that the mentioned device senses the fault and then interrupts the supply within a specified time frame.

A short-circuit device as an EntelliGuard power circuit breaker can be used to meet this requirement. However these short-circuit protection devices are normally set at values that are too high to detect normally occurring faults to earth.

The optionally available ground fault protection feature is specifically designed to detect lower currents than a standard short-circuit device and operates by residually summing the current in the phases and neutral. When a fault to Earth creates an unbalance in the system the resulting Fault is detected and the associated circuit breaker tripped, thus disconnecting the circuit. Variants with or without alarm contact option exist.

The EntelliGuard ground fault device has an adjustment range of 0.2 to 1<sup>(1)</sup> ( $\pm 15\%$ ) times the chosen breaker rating (In) and can be set in steps of 0.01 (pick up setting). To allow selectivity with other downstream protection devices there are 14 different time band settings available.

The graph indicates a number of the available 14 time bands across the full adjustment range. The table contains the minimum delay time and the maximum total interruption times for all time band settings.

The ground fault device must monitor the current in all phases and the neutral. When a 3 pole device is used in a 4 wire (3 phase + neutral) system a 4th sensor must be placed in the neutral<sup>(2)</sup>. On use of a 4 pole EntelliGuard breaker the sensor is already present in the neutral pole.

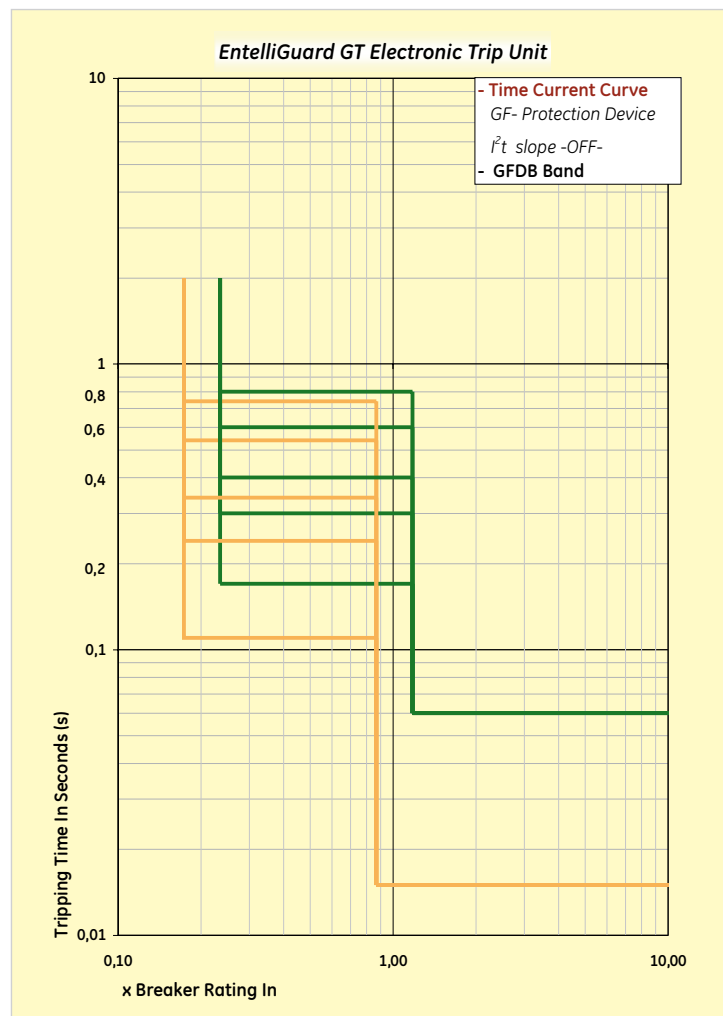
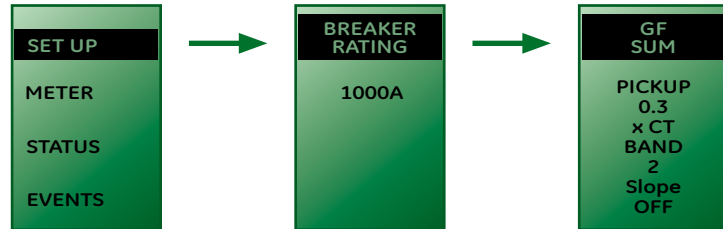

Ground fault tripping times at indicated levels per selected GFDB band -I<sup>2</sup>t slope OFF, in milliseconds

x Ir	1	2	3	4	5	6	7	8	9	10	11	12	13	14
0.2 x Max	110	120	140	170	190	240	270	340	400	450	600	700	800	900
±10% Min	50	60	80	110	130	180	210	280	340	390	540	640	740	840
0.6 x Max	110	120	140	170	190	240	270	340	400	450	600	700	800	900
±10% Min	50	60	80	110	130	180	210	280	340	390	540	640	740	840

(1) When an auxiliary supply is connected (24V DC) an extra setting range of 0.1 to 0.2 becomes available.

(2) Use a Rogowski coil of the appropriate rating, distance to breaker limited to 10 meters.



## Ground fault protection

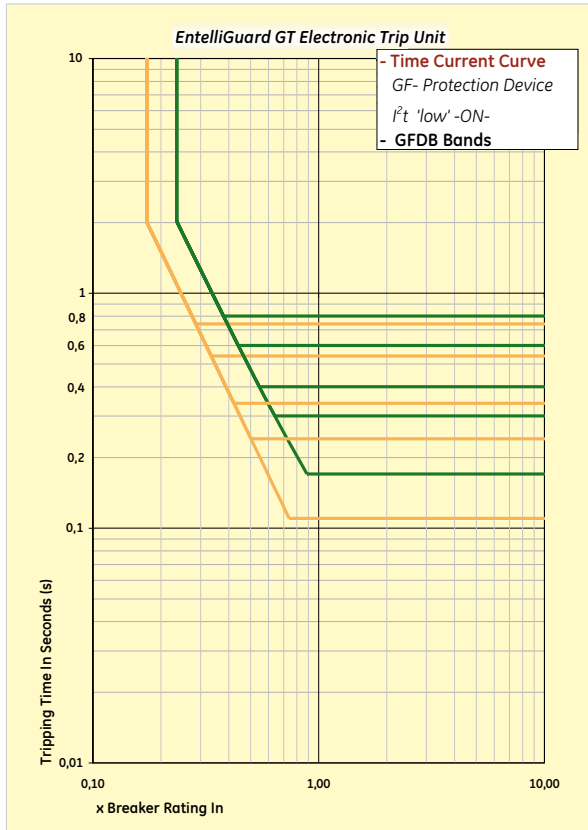

### Ground fault protection $I^2t$ bands (slope)

The GF device can also be set to a slope value. The available multiple  $I^2t$  slopes are normally used to achieve selectivity with downstream fuses or to improve selectivity with downstream circuit breakers.

The user has the possibility to choose a current adjustment of 0.2 to 1<sup>(1)</sup> times the chosen breaker rating (In) in steps of 0.01 (pick up setting) and one of 14 time bands.

The three graphs depict the available  $I^2t$  slopes (Set at position Low, Med. or High) and their intersection with several of the available 14 time bands across the full adjustment range.

**GF SUM**

PICKUP  
0.3  
x CT  
BAND  
2  
Slope  
Med.

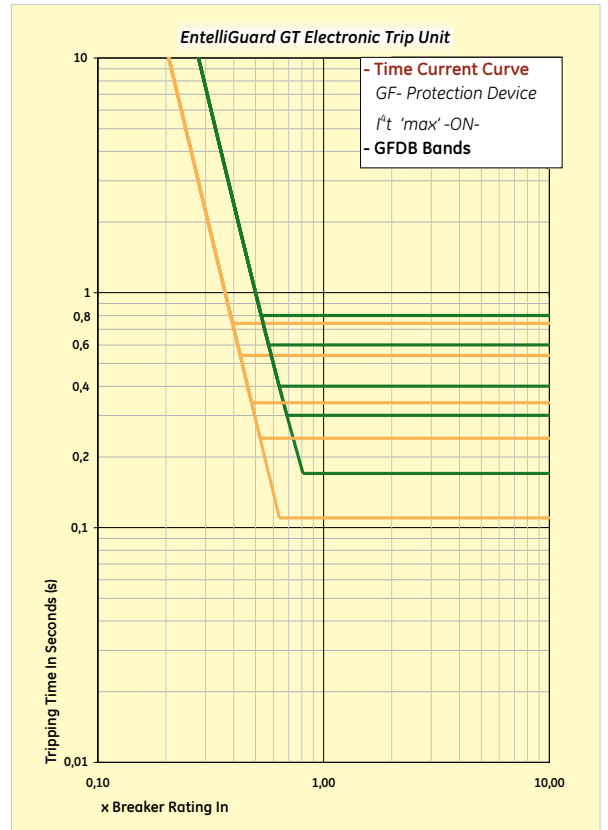
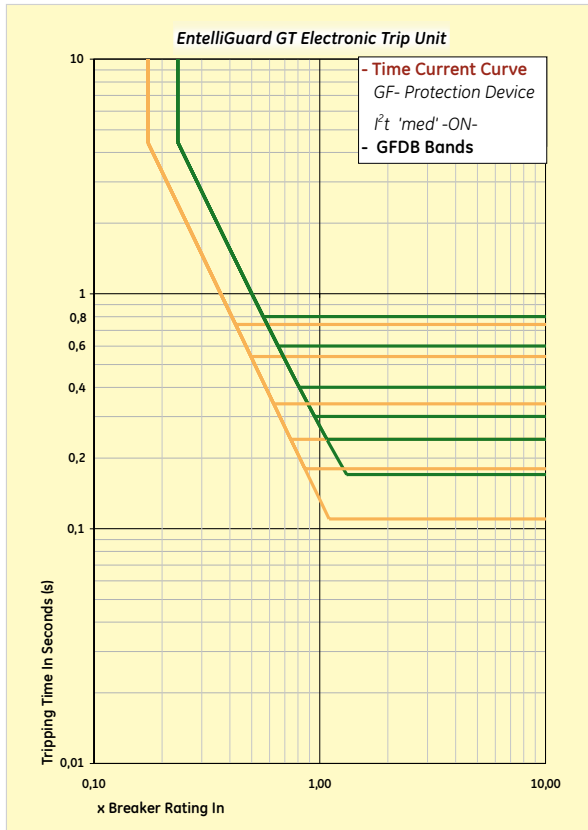

Optional on

GT-E

GT-S

GT-N

GT-H

(1) When an auxiliary supply is connected (24V DC) an extra setting range of 0.1 to 0.2 becomes available





## Ground fault protection

### Ground fault protection (GF CT)

Optionally the EntelliGuard electronic trip unit can be used with an alternative groundfault protection scheme in which the neutral to earth current is measured by an 'Earthleakage Leg Sensor' placed in the neutral and earth link of the system.

This option requires the use of an auxiliary power supply of 24V DC and the electronic trip unit needs to be set to the option CT input. An earth leg C must be placed in the near vicinity of the breaker<sup>(1)</sup> and an interposing CT needs to be mounted within the breaker. When the sensor detects a fault current the EntelliGuard trip unit trips the associated circuit breaker thus disconnecting the circuit. Variants with or without alarm contact option exist.

The EntelliGuard device has an adjustment range of 0.2 to 1<sup>(2)</sup> (+/-15%) times the chosen breaker rating (In) and can be set in steps of 0.01 (pick up setting). To allow selectivity with other downstream protection devices there are 14 different time band settings available and three I<sup>2</sup>T slope settings (same setting data and curves apply as on the standard GF residual (sum) protection).

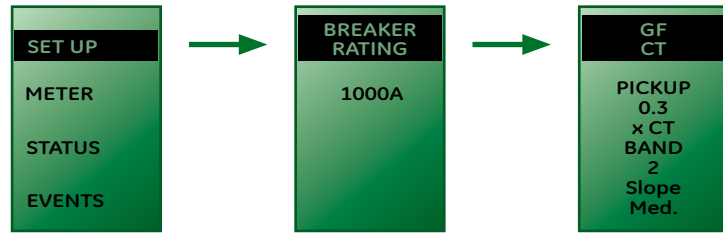

4 wire system

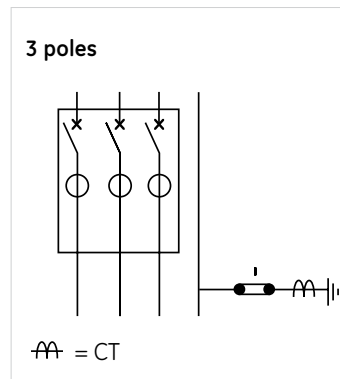

4 wire system

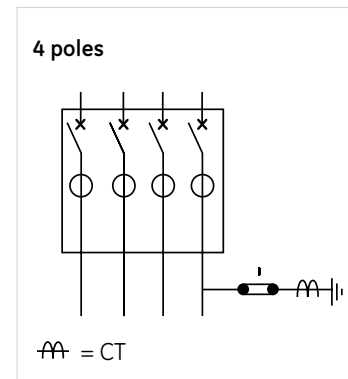

Ground fault protection

Intro

A

B

C

D

E

F

X

Optional on

GT-H

### Dual groundfault protection

#### (Residual or sum & source ground return or CT)

The EntelliGuard electronic trip unit allows the user to combine the functionality of both the GF sum and GF CT systems thus creating a sophisticated Dual Ground Fault Protection system.

Based on the chosen breaker configuration and the network configuration in which the device is used devices as indicated in the adjacent table are required. In all configurations a breaker mounted interposing current transformer is required. It is supplied as a part of the standard factory mounted assembly.

A variant of the dual ground fault protection system, trip unit types allowing unrestricted, restricted and standby earthfault protection is also available

These GT-HE trip units have an option allowing the user to choose between:

**UEF, UEF+REF, UEF+SEF, UEF+SEF+REF or SEF+REF**

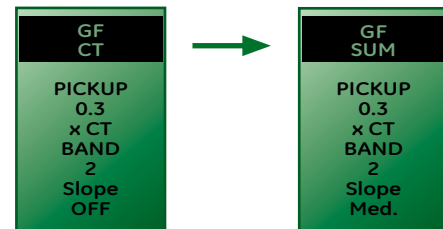

Network	EntelliGuard nr. of poles	GF residual (SUM)	GF source return (CT)	GF sum PLUS GF CT
3 wire (3 phase)	3		4th CT Int. CT	4th CT Int. CT
4 wire (3 phase + neutral)	3	4th Rg	4th CT Int. CT	4th CT Int. CT
	4		4th CT Int. CT	4th Rg 4th CT Int. CT

Optional on

GT-H

(1) Distance to breaker limited to 50 meters

(2) When an auxiliary supply is connected (24V DC) an extra setting range of 0.1 to 0.2 becomes available



## Zone selective interlock, load shedding and trip indication

Zone selective interlock  
Load shedding function (current alarm)  
Trip reason indicators (event logging) & trip operation counter.

### Zone Selective Interlock (ZSI)

This optional device has been specifically designed to combine:

- **Speed:** thus enhancing safety by reducing the hazards of arc flash incident energy. GE's instantaneous ZSI (Arcwatch\*) allows the use of the standard instantaneous switched "ON" to achieve **Speed**.

- **Full selectivity:** thus enhancing reliability. GE's instantaneous ZSI (Arcwatch) allows for **full selectivity** without switching the standard instantaneous device "OFF"

ArcWatch enabled solutions resolve the contradiction between



the speed required for safety purposes (Arc Flash Incidents) and the timing required for full selectivity.

It requires one or two simple 2 core wire to connect the ZSI inputs and outputs between two or more Electronic trip units.

If a breaker detects a fault it will send a signal to the upstream breaker to move its present time setting to another predefined higher level. If the short-circuit protection device has NO time setting band (Instantaneous), it simply gets a signal to wait another 5 half cycles before tripping. The breaker that originally detects the faults only trips after transmitting the indicated signals.

The EntelliGuard electronic trip unit uniquely offers this function on the following protection devices:

- Time delayed short-circuit protection (ST..STDB)
- Standard and source return Ground Fault protection (GF, GFDB)
- Instantaneous ( $I_l$  and  $I_{nl}$ )

When a ZSI input is received the breaker changes its time band from the standard device setting to the ZSI setting. Both of these settings are user definable and can be set independently.

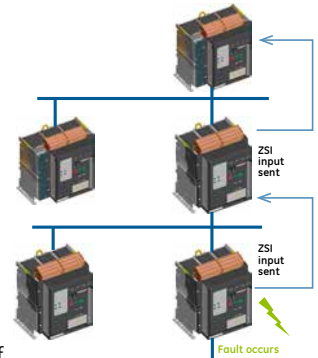

Optional on

GT-N

GT-H



### Load shedding alarm output

(Current alarm 1 & 2, see relay outputs on B.18)

The load shedding device has been designed to allow the user to switch off NON priority loads before the LT functions trips the breaker due to an overload.

It can also be used to verify the current consumption in the circuit which the EntelliGuard breaker protects and preventing it exceeding a certain pre-determined value.

The device monitors the current in the circuit and provides an alarm signal if the load in one phase of

the protected circuit exceeds a pre-defined value. The associated channel can be set ON or OFF and be adjusted in current values from 0.5 to 1 x the breaker rating ( $I_n$ ) in steps of 0.05.

When the highest measured phase current exceeds the 'ON' value set for longer than 60 seconds an output is provided to indicate that 'load shedding' may prevent an overload tripping event. When the highest measured phase current drops below the 'OFF' setting for longer than 60 seconds, the output is stopped<sup>(1)</sup>.

Standard on

GT-H

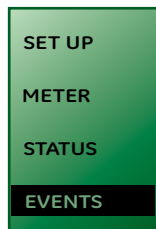

### Trip reason indicators (event logging)

Trip Operations counter

The Electronic trip unit keeps track of data indicating why the associated breaker has tripped and on how many occurrences have taken place. Accessible under the 'EVENTS' menu the trip reason indicator keeps track of a maximum of 10 events that have caused the EntelliGuard breaker to trip. The device stores the voltage, the phase's involved, the current value, the reason of the trip and the trip number (see counter). When an auxiliary voltage is connected, the time and date of the event are also stored. The trip reason indicator registers events for the following devices.

### Overcurrent (LT, ST, I GF)

Relaying functions (see page B.13)

Shunt or undervoltage release (if the associated contacts are connected via the trip unit)

Accessible under the 'STATUS' menu the trip operations counter registers a maximum of 255 overcurrent faults with their reason (LT, ST, I or GF-EF). The data can be viewed and reset through the STATUS menu pickup status option.



Standard on

GT-E

GT-S

GT-N

GT-H

(1) See section on relay outputs on page B.18

## Measurement functions and power supplies

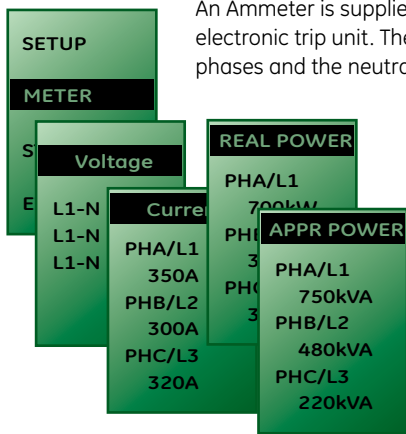

An Ammeter is supplied with each EntelliGuard electronic trip unit. The current in each of the three phases and the neutral can be viewed.

The device has an accuracy of 2% when viewed at the nominal current of the breaker and an accuracy of 5% when viewed when the breaker is running at 50 - 85% of its full load.

Parameter	Measured	Units	Resolution	Accuracy at 100% of breaker rating
Current	L1, L2, L3, N	A	0000	2%

Standard on

GT-E

GT-S

GT-N

GT-H

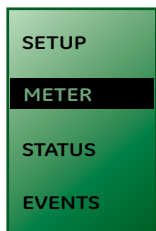

### Full measurement package (Power conditioners needed)

GT-N & GT-H type electronic trip units have an advanced measurement facility that provides the user with a comprehensive overview of all relevant electrical parameters and their values. The adjacent table indicates the available parameters, the units used and their accuracy.

A peak power demand calculation is available for real power (KW) only. Here the data is stored and when necessary renewed at a user definable pre-set time interval.

When the new peak demand value exceeds the previous stored value the new value replaces the old in memory.

The electronic trip unit has an option to reset this value.

When the option for display (meter) is opened, a calculation is initiated that calculates each value based on a one second time frame.

The device also calculates the sum of the used power in kWh, KVAh and KVAh as a total for all 3 phases. These values are kept and re-calculated every second. The electronic trip unit has an option to allow these summations to be reset.

Based on the same one second calculation method, a power demand value is determined for real (KW), apparent (KVA) and reactive (KVAR) power. If the power supply has a neutral the values are calculated per phase and as a total of all three phases.

Parameter	Measured	Units	Resolution	Accuracy at 100% of breaker rating
Current	L1, L2, L3, N	A	0000	2%
Voltage	L1, L2, L3	V	0000	2%
Power Factor	L1, L2, L3	%	00	4%
Frequency	L1, L2, L3, N	Hz	00	1 cycle
Apparent Power	L1, L2, L3	kVA	000.000	4%
Real Power	L1, L2, L3	kW	000.000	4%
Reactive Power	L1, L2, L3	KVAR	000.000	4%
Average Power demand	L1, L2, L3	kVA	000.000	4%
Energy	L1, L2, L3	KWh	000.000	4%
Peak Power Demand	L1, L2, L3	KW	000.000	4%

Standard on

GT-N

GT-H

### Power conditioners and auxiliary power supply

To use the above mentioned comprehensive measurement facilities, it is necessary to track the 3 phase and neutral network voltages and to input these values into the electronic trip unit. For this purpose the EntelliGuard line includes a number of 'Power Conditioners' that transform and condition a standard network power supply to a signal that the trip unit can safely use and read. When optioning the measurement facility for the 1st time, the electronic trip unit will require the user to set the primary voltage values.

A number of advanced trip unit options require an auxiliary supply of 24V DC. A unit that transforms and conditions a standard network power supply to 24V DC is available for this purpose. The auxiliary supply also improves the speed of the trip unit setup function at low circuit loads (<20%) and when no standard power supply is present.

A separately available Test Box Kit can also be used as a temporary power supply.

This device has a battery pack and includes a 24V DC auxiliary power supply.

Accessory for

GT-S

GT-N

GT-H



## Protective relaying functions; relay and trip unit inputs Wave form capture option

- SET UP
- METER
- STATUS
- EVENTS

**Protective relaying functions**  
The GT-H Electronic trip unit has five protective relay functions. These can be switched ON or OFF and when active produce an alarm signal that is added to the event Log and transmitted through the communication bus. Each relay function can be configured to trip the breaker or/ and to send an alarm signal via a relay output.

Protective relay	Adjustability	Steps	Accur.	Trips breaker
<b>Overvoltage</b>	110% -115% of line voltage	1%	2%	ON or OFF
Overvoltage delay	1 to 15 seconds	1sec	± 0.1 s	
<b>Undervoltage</b>	30% - 85% of line voltage	1%	2%	ON or OFF
Undervoltage delay	1 to 15 seconds	1sec	± 0.1 s	
<b>Voltage unbalance</b>	10% -50% difference between highest and lowest phase when compared to average	1%	2%	ON or OFF
Voltage unbal. delay	1 to 15 seconds	1sec	± 0.1 s	
<b>Power direc. reversal</b>	Line-to-load OR load-to-line			ON or OFF
Power reversal setting	From 10 to 990kW	10kW	2%	
<b>Current unbalance</b>	10% -50% difference between highest and lowest phase when compared to average	1%	2%	ON or OFF
Current unbal. delay	1 to 15 seconds	1sec	± 0.1 s	

Standard on

GT-H

- SET UP
- METER
- STATUS
- EVENTS

**Relay outputs**  
There are two programmable relay outputs available rated at 1A 30V AC or DC. The first is dedicated to the reduced instantaneous device whilst the second can be assigned to single functions, a group of functions or to the protective relays functions mentioned above. Accessible under the 'SETUP' the output is wired out through the secondary terminals of the breaker as indicated on page E.7.

**Relay output reset (group 2, 3, & 8)**

If a 24 V DC power supply is present and the event associated with the relay closure causes the breaker to trip the contacts will not change position. A breaker re-set and re-closure will reset the contacts to their original open position.

Function	Group
GF alarm <sup>(1)</sup>	Assigned to group 1
Over-current trips (LT, ST, INST, GF)	Assigned to group 2
Protective relays	Assigned to group 3
Current alarm 1	Assigned to group 4
Current alarm 2	Assigned to group 5
Health status	Assigned to group 6
GF alarm and GF trip indication	Assigned to group 8

(1) Only works when a trip unit has the ground fault alarm installed.

**Relay output reset (group 1, 4, 5 & 6)**  
If the reason of the contact closure is removed the contact will re-open. This typically occurring when a health status warning is produced or when a current alarm drops below it's threshold. If the breaker trips whilst the relay contacts are activated the contacts will be reset and revert to their original open position.

Optional

GT-E

GT-S

GT-N

GT-H

- SET UP
- METER
- STATUS
- EVENTS

**Electronic trip unit INPUTS**  
There is a total of 2 programmable inputs available. The first is dedicated to switch the reduced instantaneous ON. The second can be used to trip the breaker. The inputs are suitable for voltages up to 24V AC or 30V DC. Accessible under the 'SETUP' the outputs are wired out through the secondary terminals of the breaker as indicated on page E.7.

Optional

GT-E

GT-S

GT-N

GT-H

- SET UP
- METER
- STATUS
- EVENTS

**Wave form capture option**  
When a fault has taken place, it can be of importance to visualize the event. The wave form capture option included in the GT-H type electronic trip unit can track and visualize any fault event. The device tracks 8 cycles, 4 before and 4 after the event with resolution of 48 samples per cycle at 50Hz and stores the results in memory. It registers

events in all three phases and the neutral. After the event, the waveform event is stored and can be accessed by using the waveform client module of the Enervista software. When the upload into this software is complete, the Trip Unit will reset this function and be available to register the next event. The trip unit toolkit software can also be used to access the Waveform capture feature.

Standard on

GT-H



Communications

Neutral protection, reset choice, rating plug and test kit

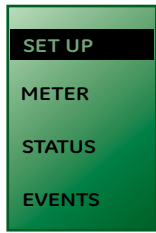

Communications

A number of the GT electronic trip unit types can be optioned to allow the breaker & trip unit combination to communicate data bi-directionally through Modbus or Profibus. The communication option needs a 24 V auxiliary voltage input capable of supplying 90mA for the Modbus option and 240mA for the Profibus option.

For frame T, the Modbus and Profibus need to be connected with the communication modular for operation. In frame 1/2/3, Modbus and Profibus can be directly connected to the trip unit without the use of any interfaces. In combination with communications the use of the specifically designed command closing coil and auxiliary contacts with signal ratings are required.

Trip unit parameters as over current settings, protective relay functions, alarm settings etc. can

be accessed through communications. A locking password is provided that prevents unauthorized changes through communication or the keypad.

The Modbus variant is fully compliant with the Modbus protocol and uses 2 a wire 485 connection. The device is configured to stay on one fixed baud rate, or to cycle through the baud rates until communication is established. The link host can operate at baud rates between 300 and 19.200.

The Profibus protocol is integrated in specific models of the GT-H trip unit and uses a four wire RS 485 connection. Profibus DP is supported in A-cyclic and cyclic mode. For the cyclic mode the associated gsd file is available on request.

A communication register can be supplied for both versions.

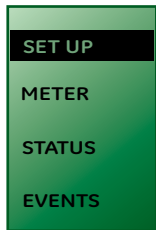
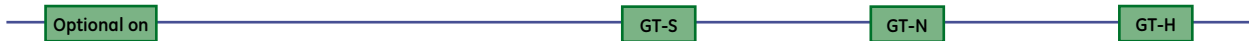

Neutral protection

When inserted into a 4 pole breaker the EntelliGuard electronic trip unit senses that the breaker in which the device is installed has a neutral pole. Via the set Up menu, a neutral setting option then becomes available in which the LT, ST and I protection device can be jointly set to one of the following values:

0%, 50%, 63% or 100%. x the values set for the phase protection device.

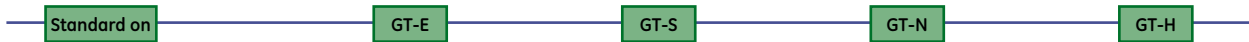

Reset choice function

When a fault has occurred the trip unit trips the associated breaker. It is then deemed normal installation practise to verify the reason of the fault before reconnecting power by resetting and switching the breaker on. The advanced options included in the EntelliGuard trip unit provide the user with the fault reason, magnitude and location, thus allowing the user to easily establish the required corrective actions. To follow this procedure trip unit reset function should be set to MANUAL.

However, in some cases it is required that the breaker resets itself automatically. If this functionality is required, the reset function should be set to AUTOMATIC. Or if the reset function needs to be controlled from remote location, the selector switch on the trip unit front shall be chosen to manual reset mode, and the remote reset coil is required together for functionality. A selector switch on the trip unit front face allows the user this choice<sup>(1)</sup>.



Full range rating plug

Each EntelliGuard electronic trip unit must be equipped with a separately available rating plug to allow it to function correctly. The full range rating

plug is plugged in to a jack on the trip unit front face. When this device is not installed, the trip unit will revert to its minimum setting, which has as value of 16-18% of the breaker rating in.

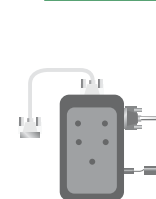

Test and set-up kit

To verify that the electronic trip unit is interfacing correctly with the Breaker and to establish if the circuitry in the trip unit is functioning correctly, a test kit is available. The device has a battery pack and a 24V auxiliary supply to allow its use in a secondary function as power supply of the Trip unit. The device can be plugged into a jack on the trip unit

front face. For more advanced functionality a FREE software is available for download that allows users to customize, set, monitor, and test trip units using the comfort of a laptop. Downloadable from: [ex.geindustrial.com](http://ex.geindustrial.com)

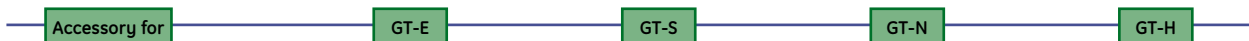

(1) Kits are available that allow the user to block the switch in one of either position (see page A.26)



## Overview of GT electronic trip unit functionality

		GT-E	GT-S	GT-N	GT-H	Remarks
Setting interface	LCD screen allowing access to 4 distinct menus	X	X	X	X	--
	Touch pad adjustments	X	X	X	X	--
	Multilingual	X	X	X	X	--
	Adjustable manual or automatic RESET option	X	X	X	X	--
Long time or overload current protection	6 primary current settings with FULL RANGE rating plug <b>1; 0.975; 0.9625; 0.95; 0.45 &amp; 0.4</b> x breaker rating In	X	X	X	X	--
	11 secondary current settings Ir	X	X	X	X	--
	<b>1; 0.95; 0.9; 0.85; 0.8; 0.75; 0.7; 0.65; 0.6; 0.55; 0.5</b> x primary setting Ie	X	X	X	X	--
	Resulting setting Range <b>0.2 to 1</b> with <b>66</b> set points	X	X	X	X	--
	Possibility to switch OFF	-	-	-	X	--
	22 thermal protection (C type) time bands available ranging from class 0.5 to 40 (bands at 7.2 x Ir)	X	X	X	X	--
	22 F type (fuse) time bands available	-	-	-	X	--
	13 standard inverse shape protection bands available (L = 0.5-20)	-	-	-	X	--
	13 very inverse shape protection bands available (L = 0.5-20)	-	-	-	X	--
	13 extremely inverse shape protection bands available (L = 0.5-20)	-	-	-	X	--
	Neutral protection 0-50%-63%-100%	X	X	X	X	--
Short time short-circuit current protection	Cooling function and thermal memory	X	X	X	X	--
	Setting RANGE from <b>1.5 to 12</b> x Ir (LT setting)	X	X	X	X	--
	Steps of 0.5 (A total of 22 settings)	X	X	X	X	--
	Possibility to switch OFF	-	-	-	X	--
Instantaneous short-circuit current protection	17 time delay settings (STDB) ranging from 30 to 940 milliseconds delay setting result in a 90 to 1000 milliseconds clearing time	X	X	X	X	--
	Clearance times to IEC 40979-1 and IEC 60364	X	X	X	X	--
	3 I <sup>2</sup> t protection time bands available	X	X	X	X	--
	I <sub>set</sub> setting RANGE from <b>2 to 15</b> x Ie (primary setting)	-	X	X	X	--
	Steps of 0.5 (a total of 28 settings)	-	X	X	X	--
	Possibility to switch OFF	-	X	X	X	--
	<b>Selective execution</b>	-	X	X	X	--
	Fixed instantaneous or HSIQC protection	X	X	X	X	--
	I <sub>set</sub> setting RANGE from <b>2 to 30</b> x Ie (primary setting)	-	O	O	O	--
	Possibility to switch OFF	-	O	O	O	--
	<b>Selective execution</b>	-	O	O	O	--
Ground or earth fault protection	Fixed instantaneous or HSIQC protection	X	X	X	X	--
	I setting RANGE from <b>1.5 to 15</b> x Ie (primary setting)	-	-	X	X	--
	Steps of 0.5 (A total of 29 settings)	-	-	X	X	--
	Possibility to switch OFF	-	-	X	X	--
	Remote and local ON and OFF with position indication signal	-	-	X	X	--
	Setting RANGE from <b>0.1 to 1</b> x In (breaker rating) <sup>(1)</sup>	O	O	O	O	--
	Steps of 0.01 (A total of 92 settings)	O	O	O	O	--
	Possibility to switch OFF	O	O	O	O	--
	14 time delay settings (GFDB) ranging from 50 to 840 milliseconds delay setting resulting in a 110 to 900 milliseconds clearing time	O	O	O	O	--
	Clearance times to IEC 40979-1 and IEC 60364	O	O	O	O	--
	3 I <sup>2</sup> t protection time bands available	O	O	O	O	--
Measurement package (for measurements using voltage power conditioners are needed)	Residual principle	O	O	O	O	--
	Source ground return principle <sup>(2)</sup>	-	-	-	O	N
	UEF, REF and SEF applications possible	-	-	-	O	N
	Combinations of UEF, REF and SEF applications possible	-	-	-	O	N
	Current (L1, L2, L3, N)	X	X	X	X	--
	Voltage (L1, L2, L3)	-	-	X	X	C
	Energy (kWh) total real	-	-	X	X	C
Protective relaying	Real power (L1, L2, L3, total)	-	-	X	X	C
	Apparent power (L1, L2, L3, total)	-	-	X	X	C
	Reactive power (L1, L2, L3, Total)	-	-	X	X	C
	Total power (L1, L2, L3, total)	-	-	X	X	C
	Power (kW) peak (total)	-	-	X	X	C
	Demand power (kW) (total)	-	-	X	X	C
	Frequency (L1, L2, L3)	-	-	X	X	--
	Voltage unbalance	-	-	-	X	N
	Undervoltage	-	-	-	X	N
	Overvoltage	-	-	-	X	N
	Profibus	-	-	-	X	N
Diagnosics & wave form capture	Load shedding (current alarm 1 & 2)	-	-	-	X	--
	Current unbalance	-	-	-	X	N
	Power reversal	-	-	-	X	N
	Trip target (trip reason indication)	X	X	X	X	--
	Trip info (magnitude / phase)	X	X	X	X	--
	Waveform capture	-	-	O	O	N
	Trip counter	X	X	X	X	--
	Event logger (trip events)	X	X	X	X	--
	Good and bad health indicator	X	X	X	X	--
	Watchdog	X	X	X	X	--
	Other	Zone selective interlock on ST, GF and I	-	-	O	O
Shunt trip status input (2 inputs)		-	-	-	O	--
UVR trip status input (2 inputs)		-	-	-	O	--
General relay outputs and electronic inputs		X	X	X	X	--
Communication 2 way <sup>(2)</sup>		-	O	O	O	N
Modbus <sup>(3)</sup>		-	O	O	O	N
Profibus <sup>(3)</sup>		-	-	-	O	N
24V DC auxiliary power supply		O	O	O	O	--
Text kit with power support function	O	O	O	O	--	

### Remarks

N indicates that a 24V auxiliary voltage supply is required

C indicates the need of a power conditioner

(1) Without a 24V auxiliary power supply, the lowest setting is 0.2

(2) With a UEF, SEF & REF option installed, RELT is unavailable

(3) Communication module is required for frame T breaker (extra plug & harness)

### Key

X - Present; O = Optional; - = Not possible



Time current curves (cold state)

LT protection device

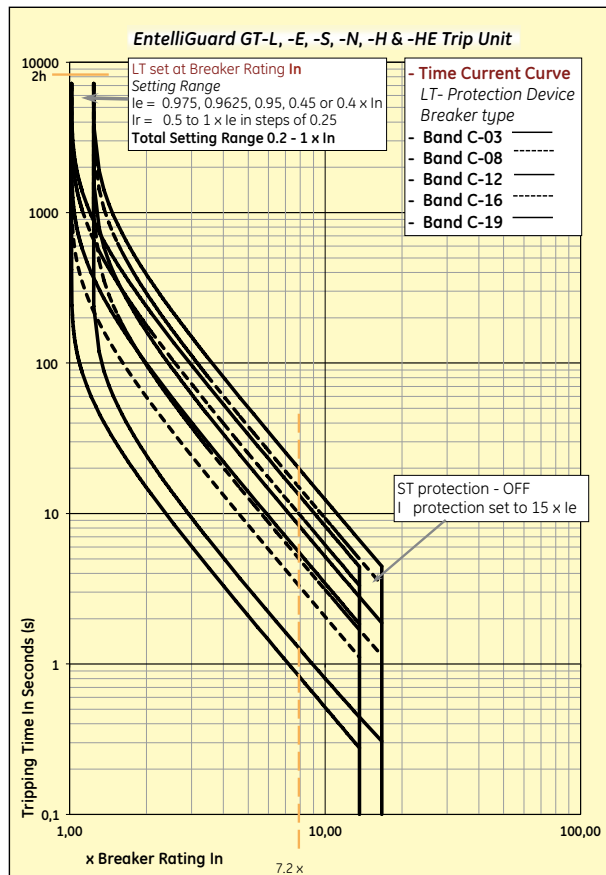
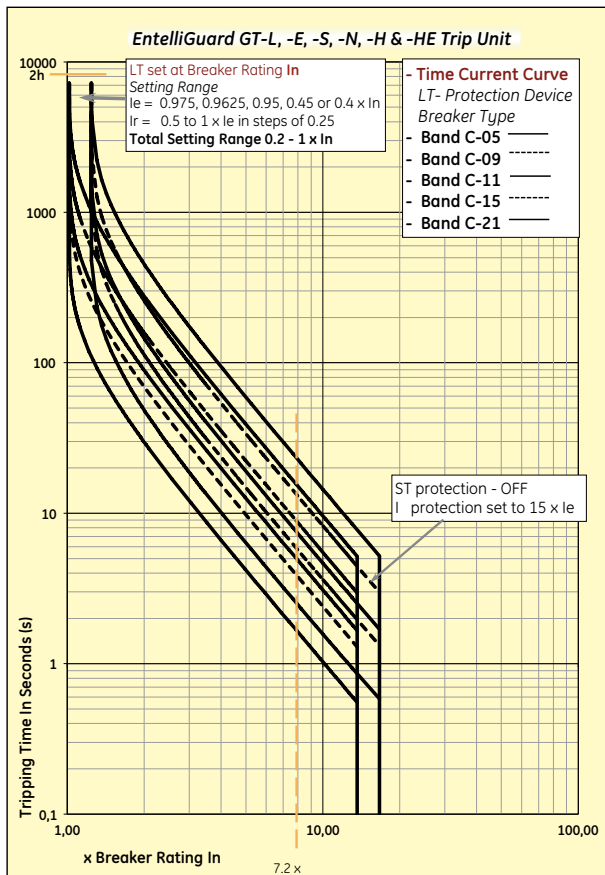
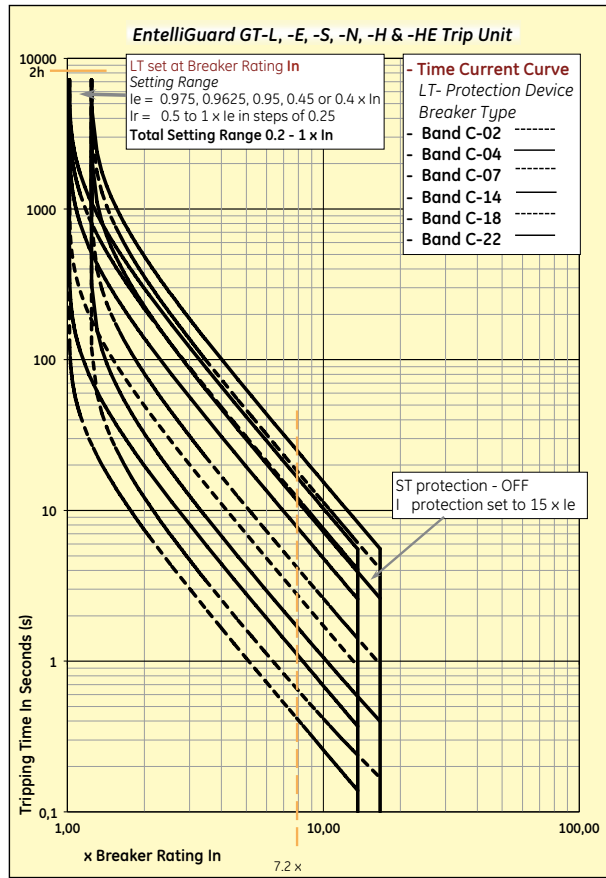
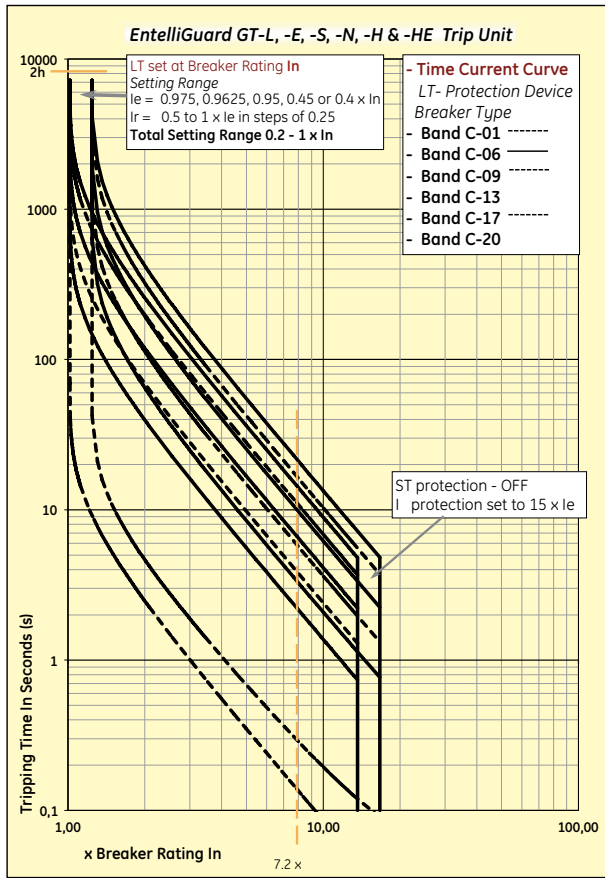

## Time current curves (cold state)

LT protection device

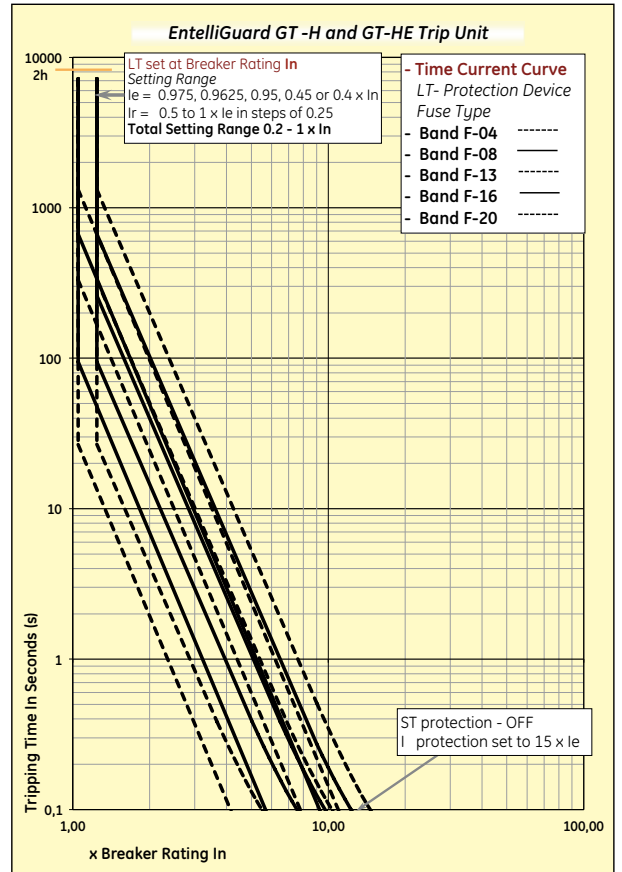
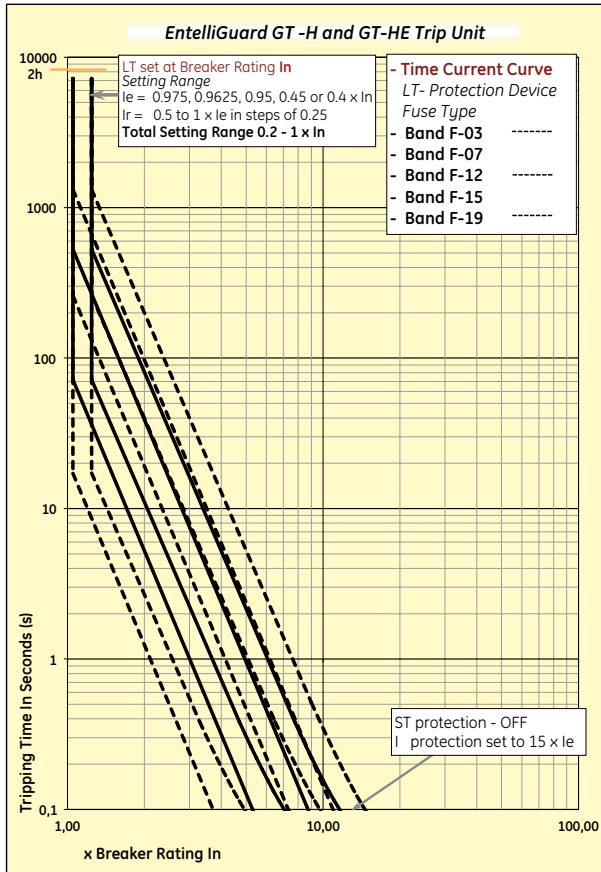
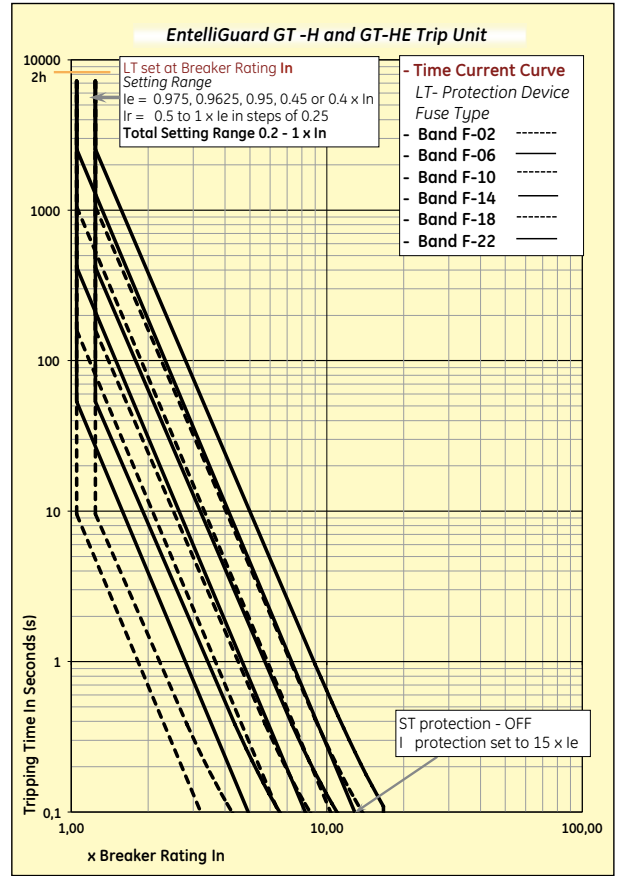
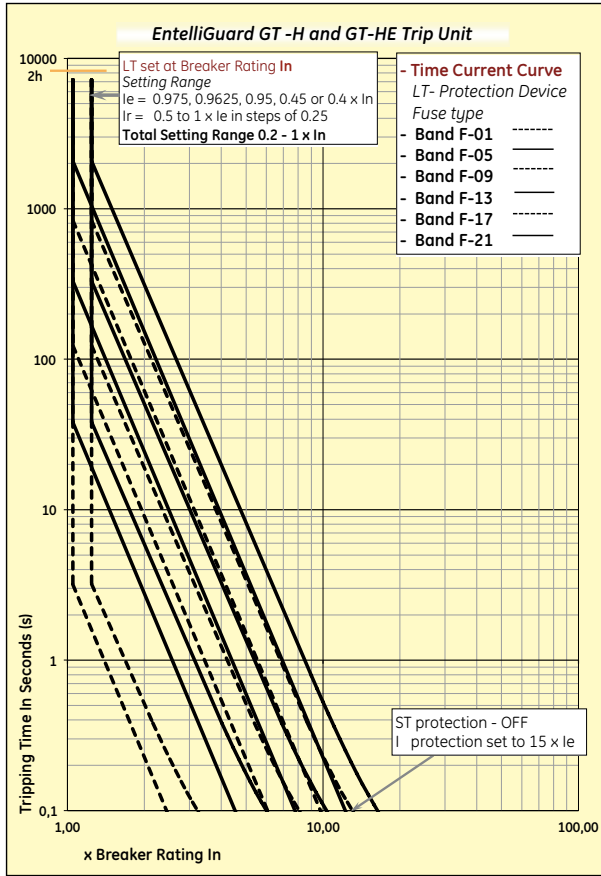



Time current curves (cold state)

LT & ST protection device

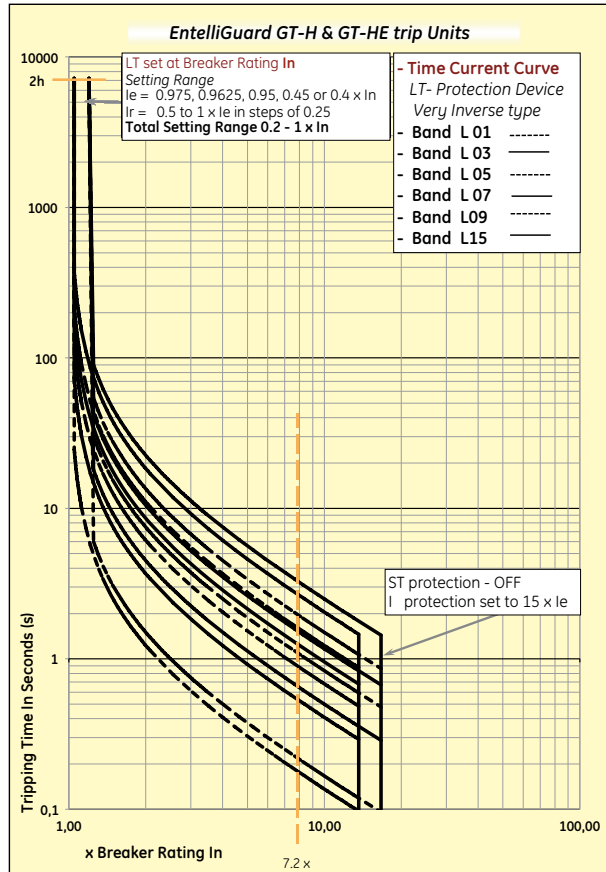
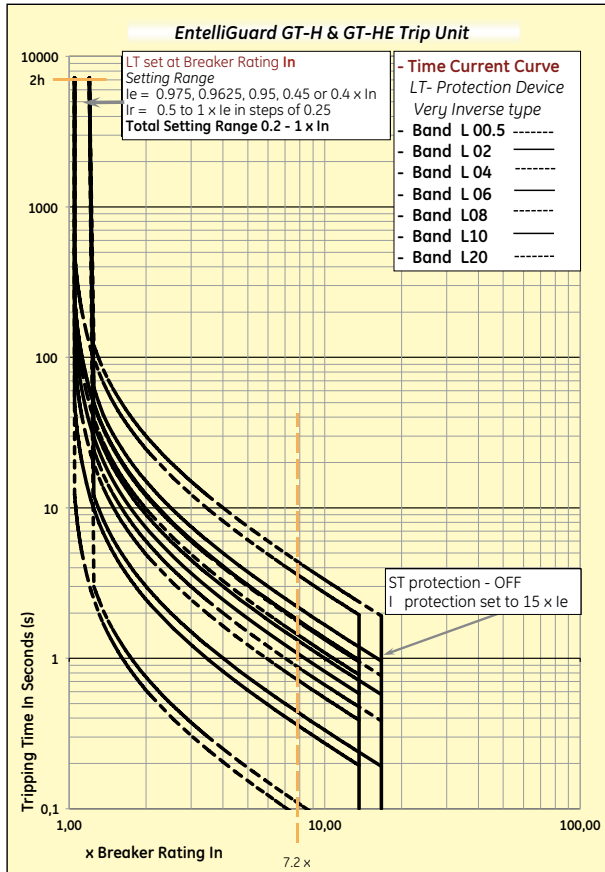
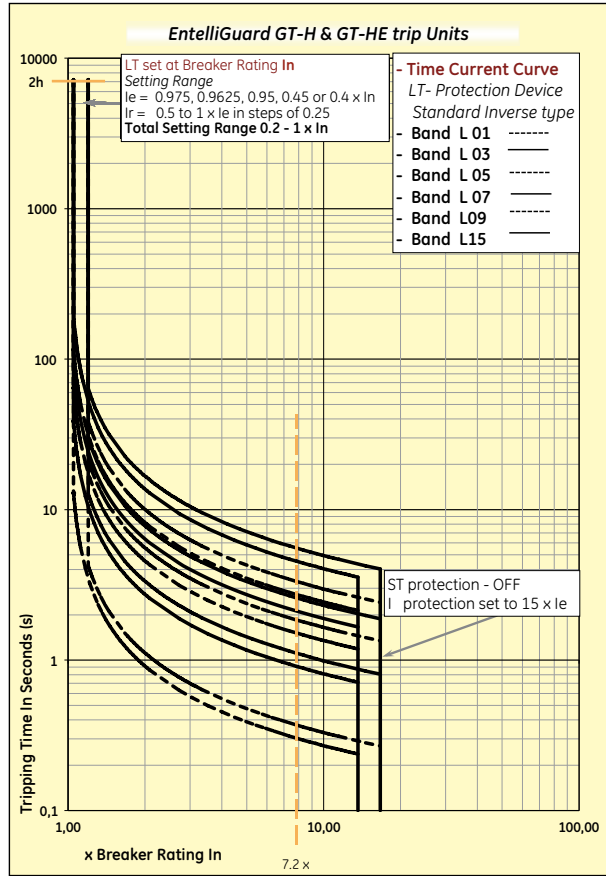
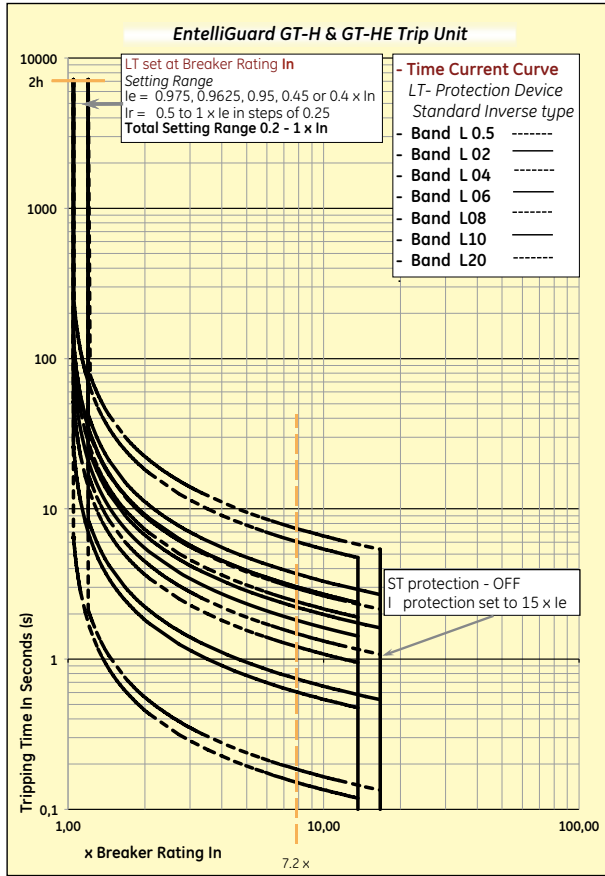

## Time current curves (cold state)

ST protection device

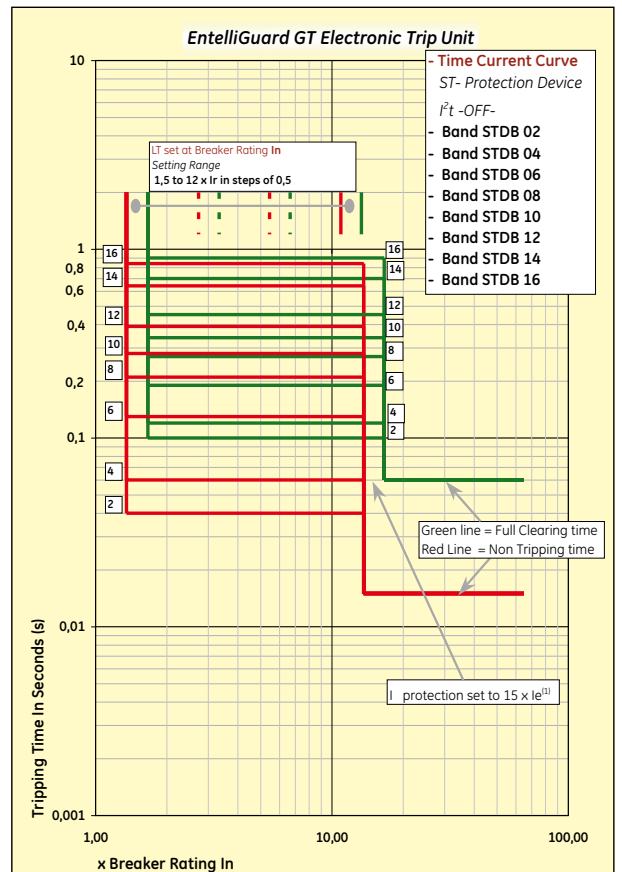
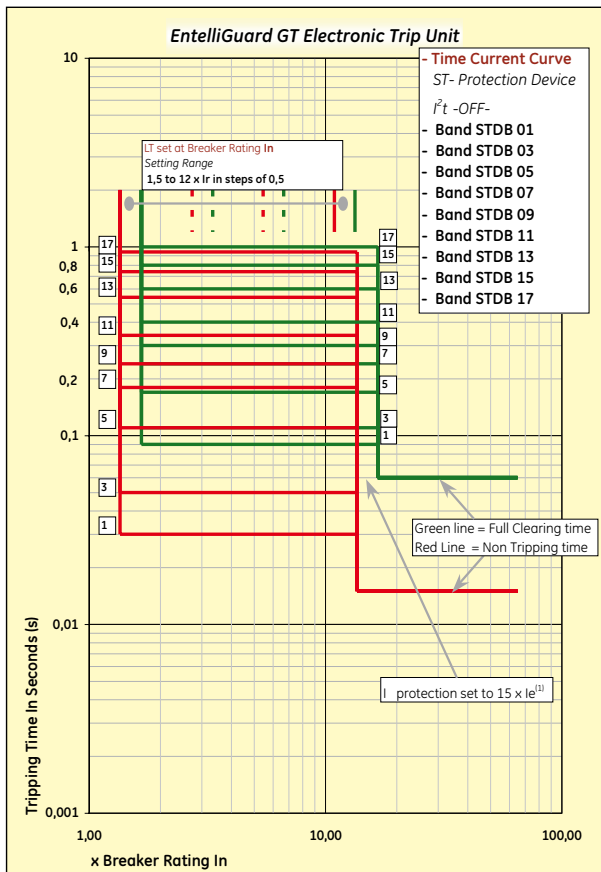
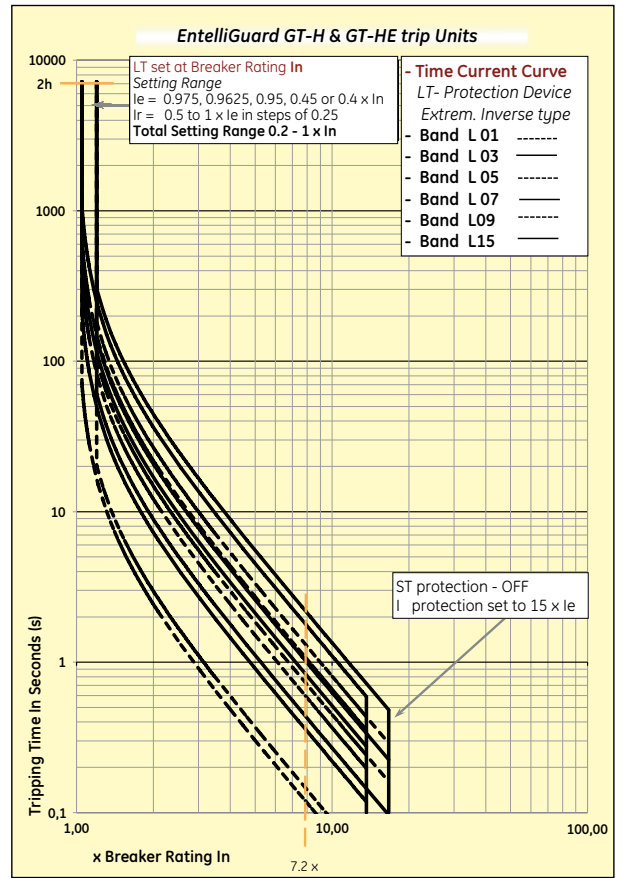
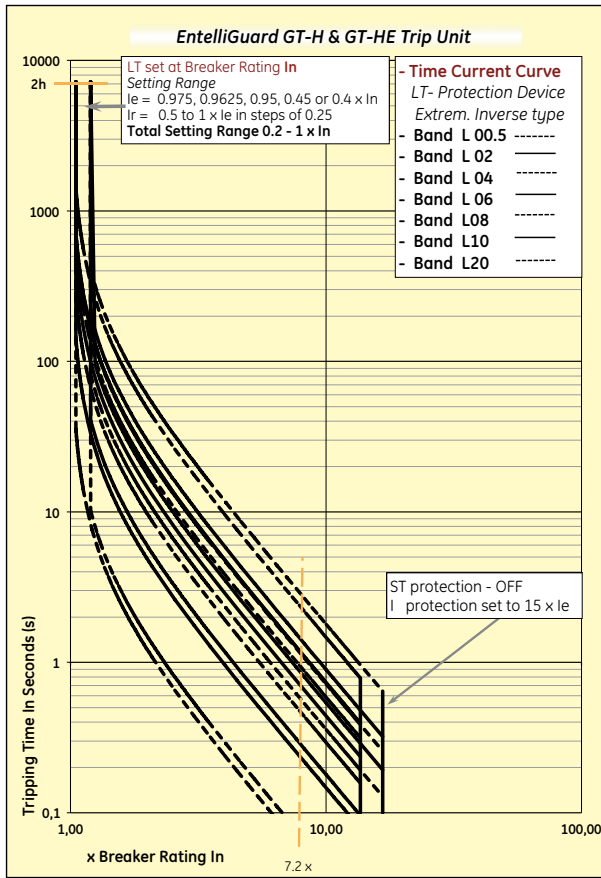

Time current curves (cold state)

ST protection device

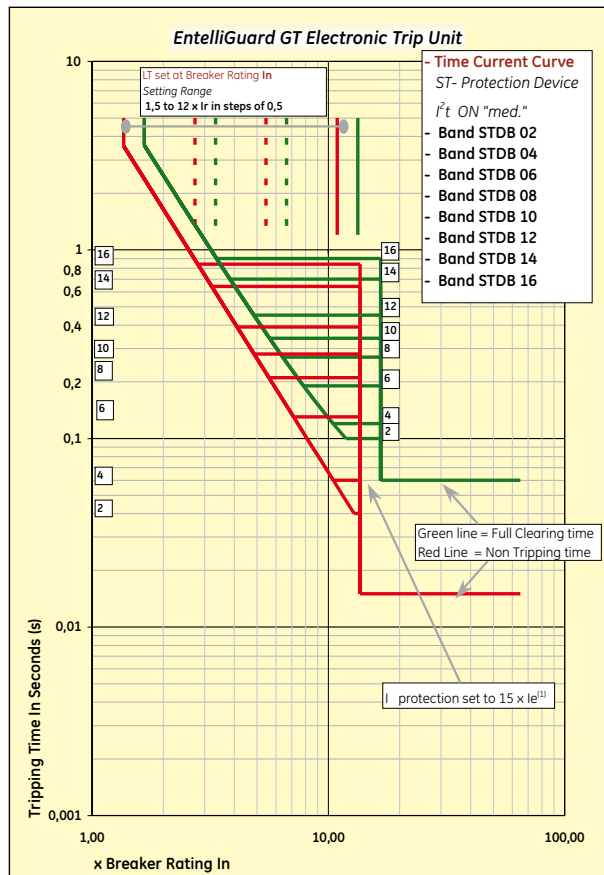
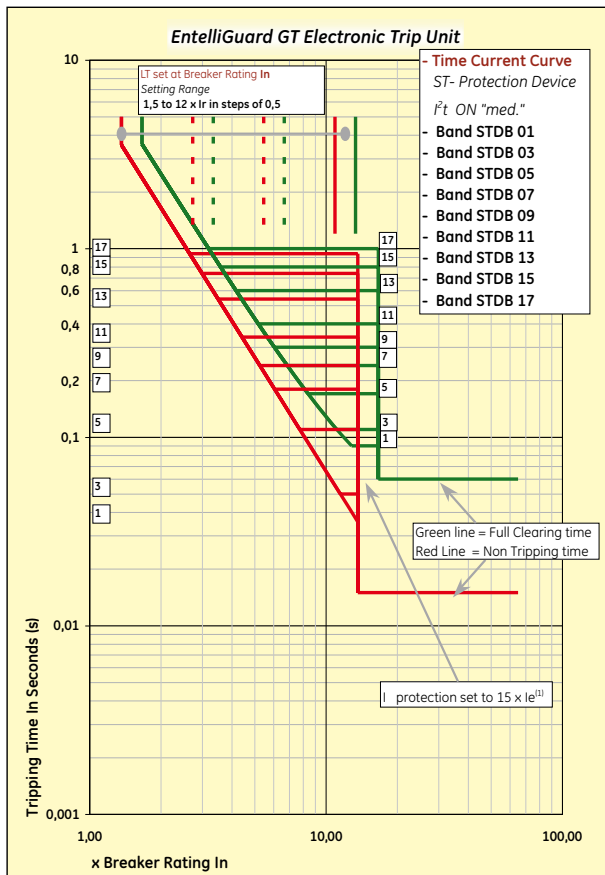
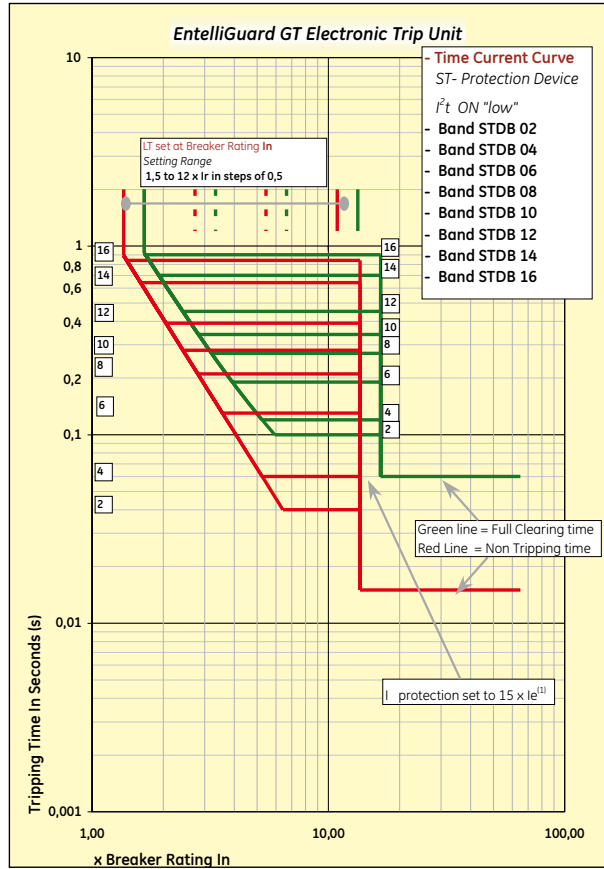
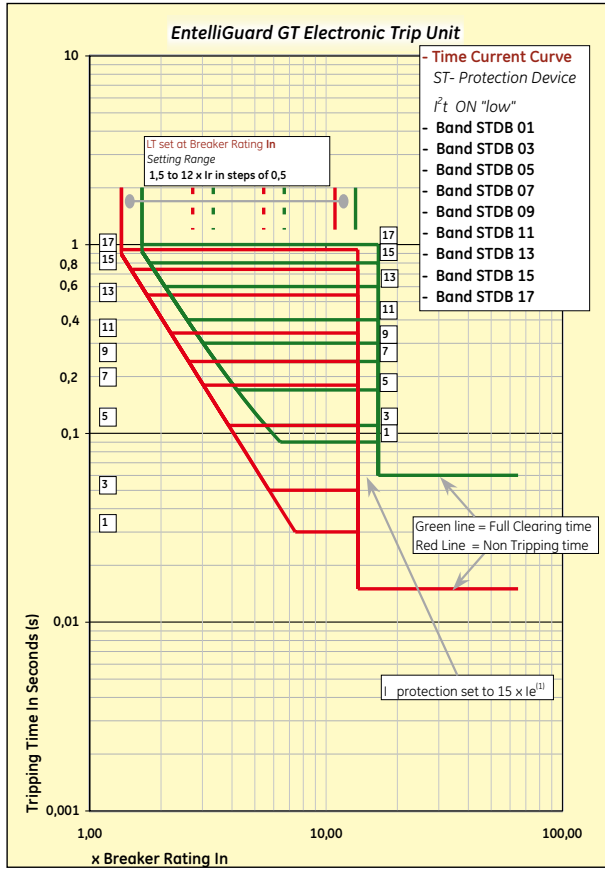

Time current curves

Intro

A

B

C

D

E

F

X



## Time current curves (cold state)

ST and I protection device

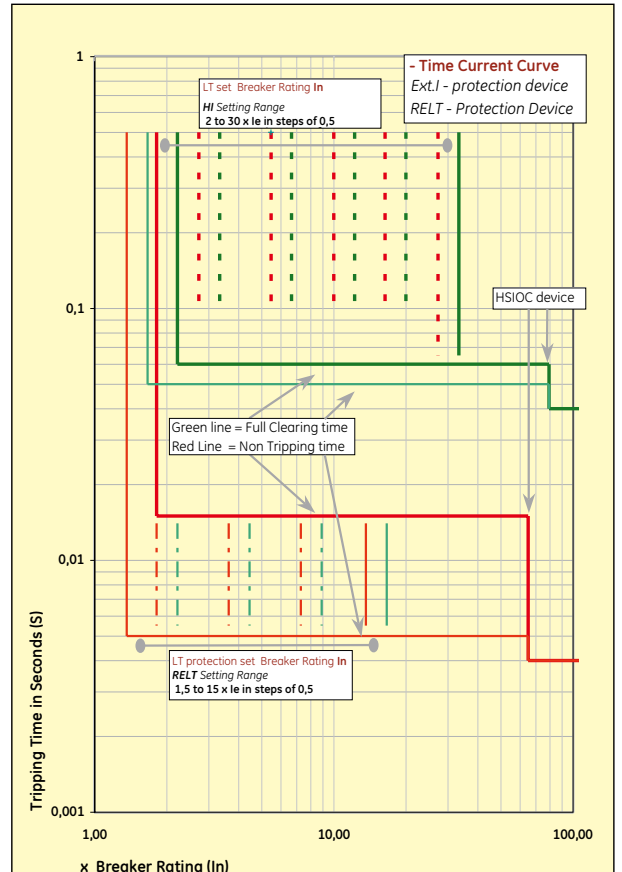
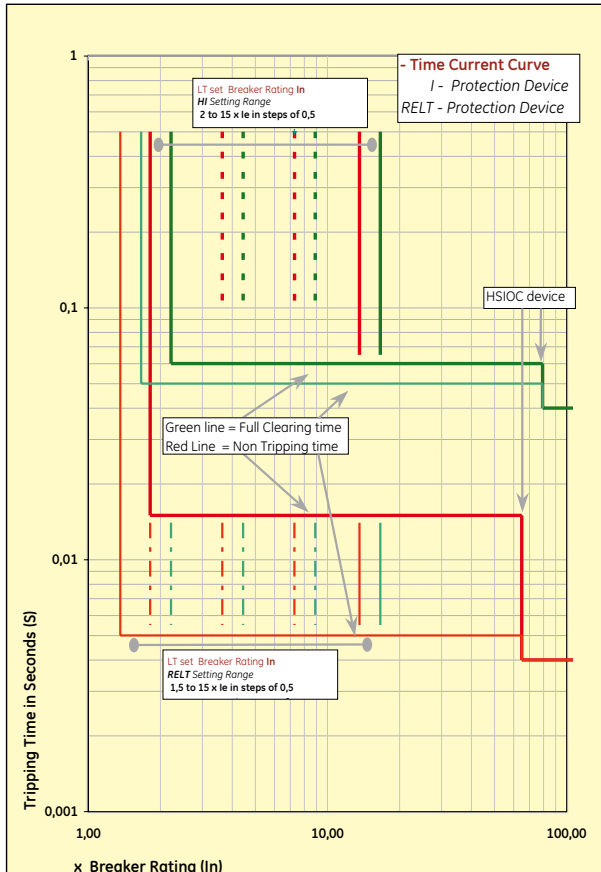
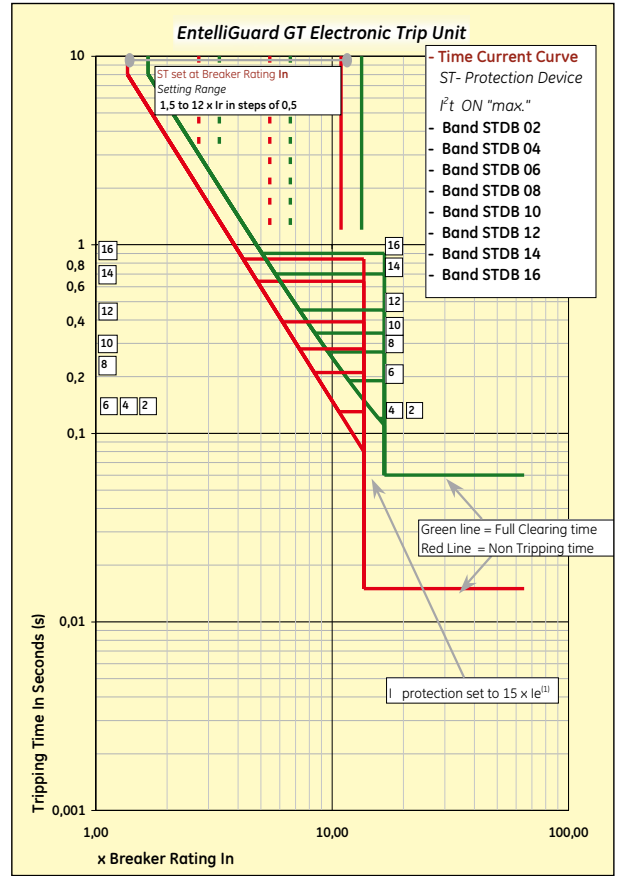
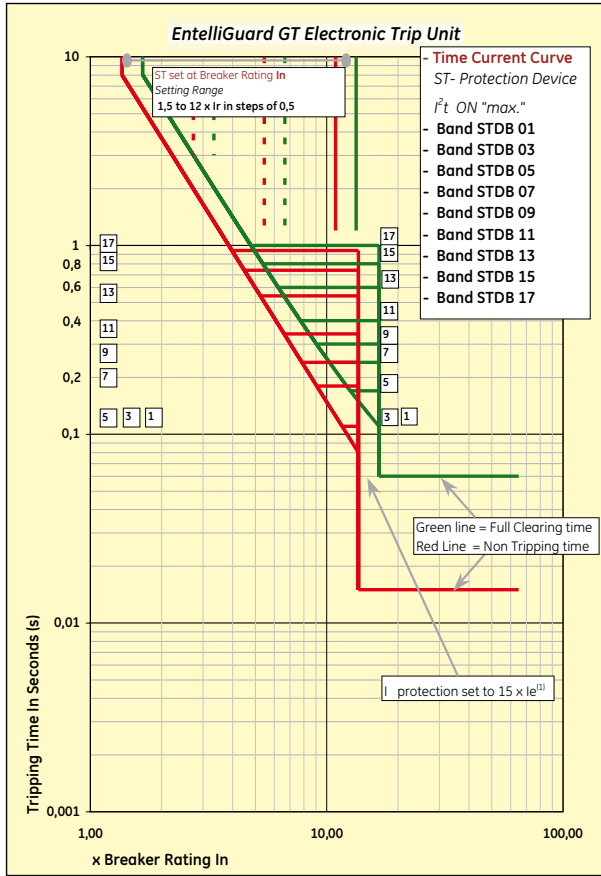

Time current curves (cold state)

HSIOC and GF protection device

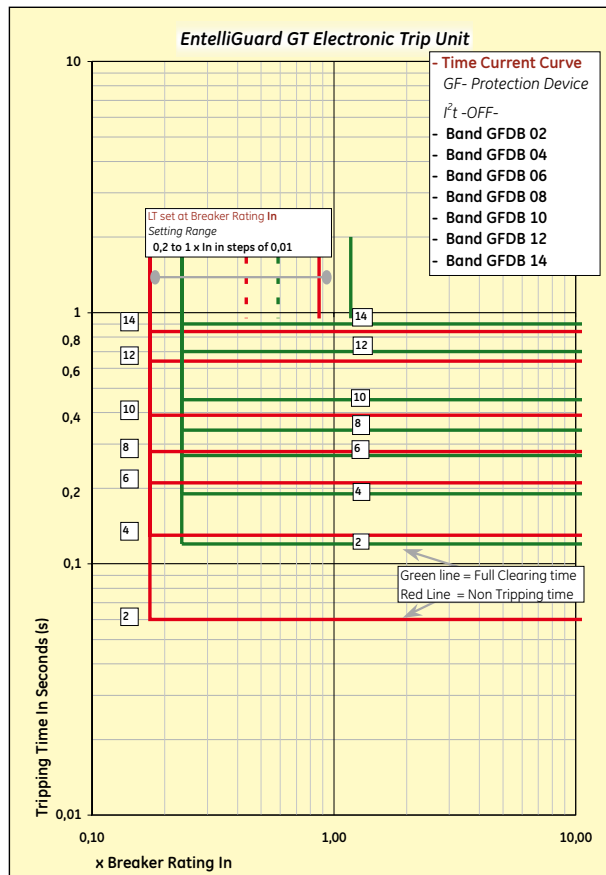
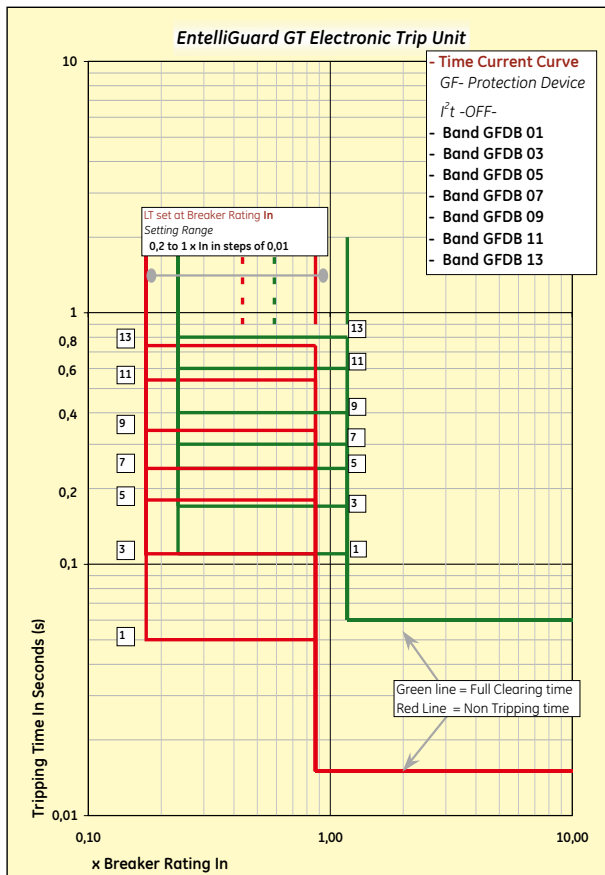
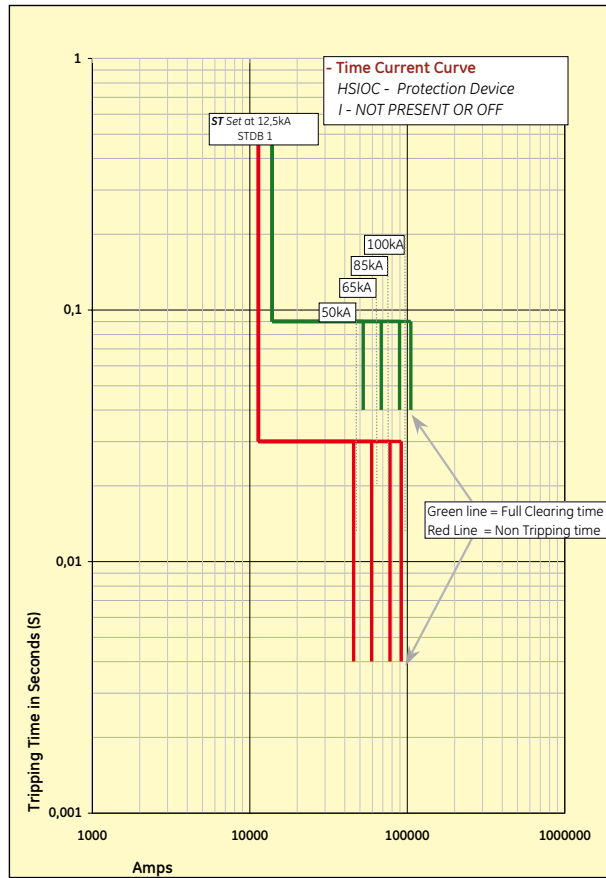
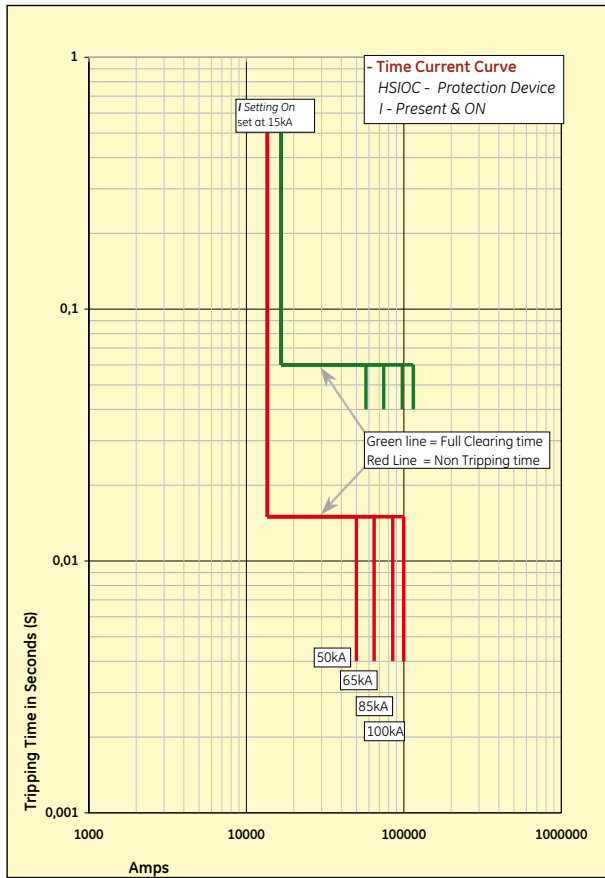

## Time current curves (cold state)

GF protection device

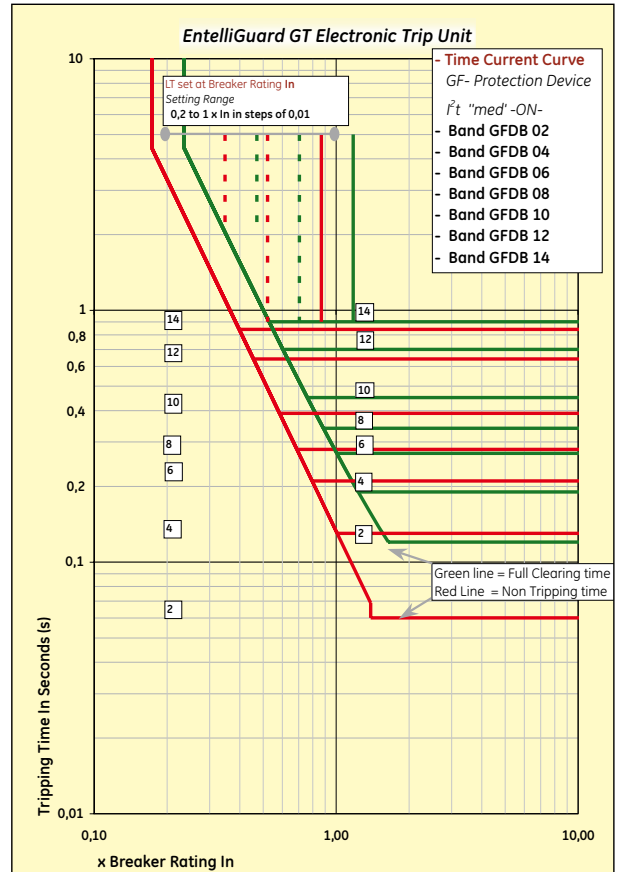
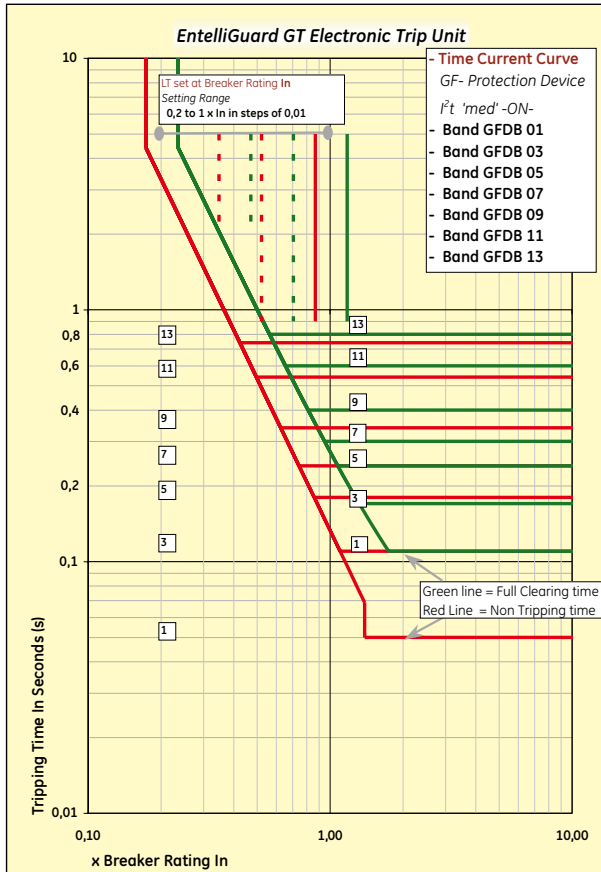
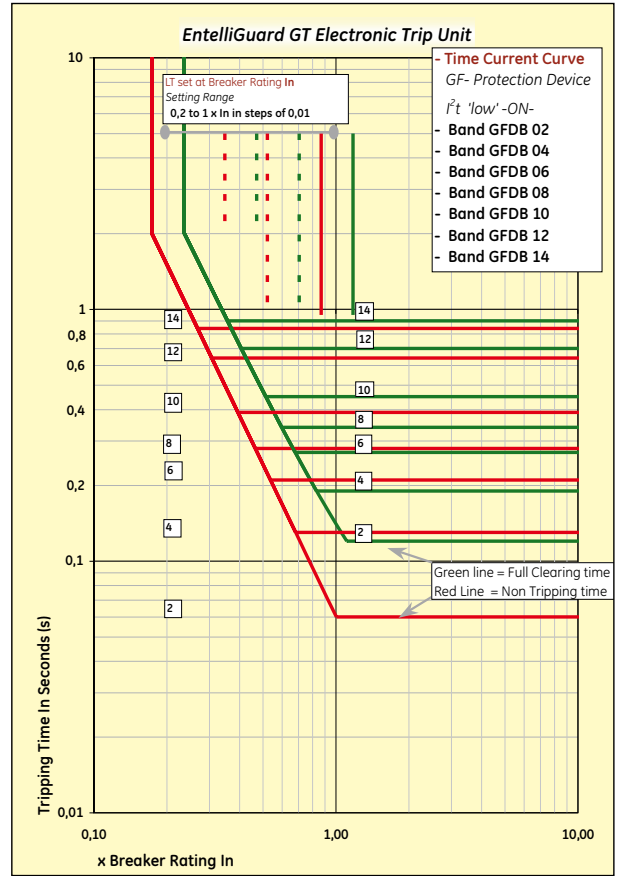
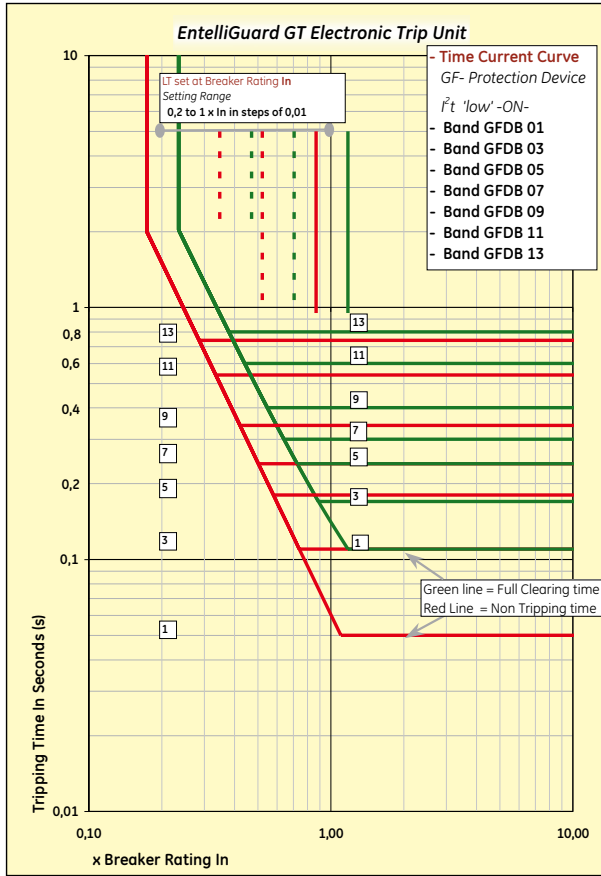

Time current curves (cold state)

Terminology

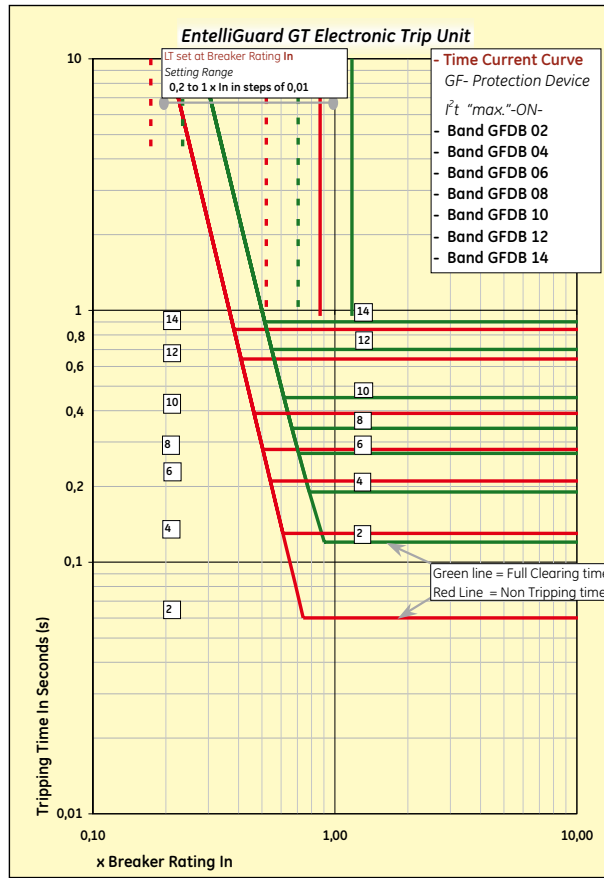
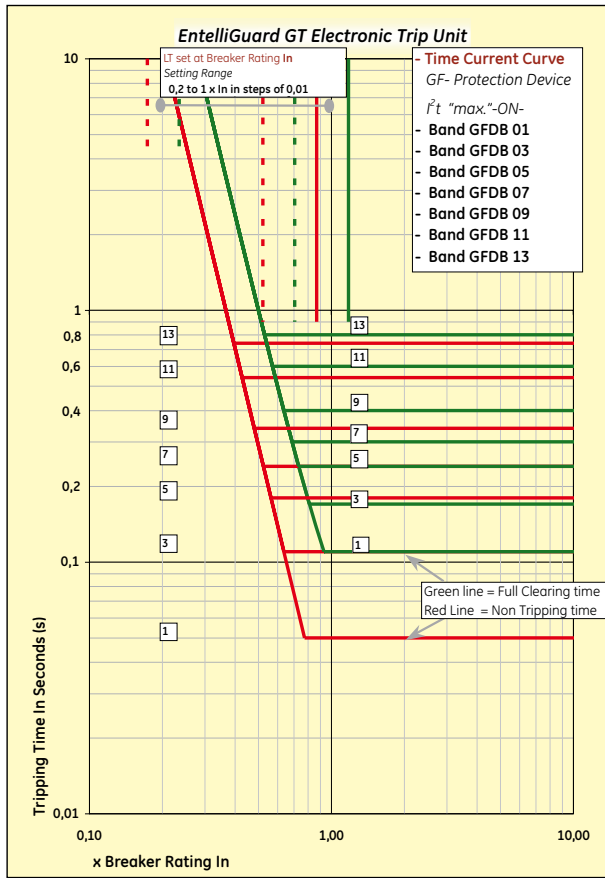

Denomination	Description
In	Current rating of breaker
Ie	Primary current setting
Iu	Maximum breaker user current (see section D)
LT	Long time or overload protection
ST	Short time or timed short-circuit current setting
I	Standard or extended instantaneous setting
GF	Groundfault
EF	Earthfault
Ir	LT or overload current setting
Ist	ST or timed short-circuit current setting
Ii	Instantaneous short-circuit current setting
Ig	Ground or earthfault current setting
LTDB	LT or overload time delay band (C = breaker type, F = fuse type)
STDB	ST or short-circuit time delay band
I <sub>t</sub>	'Slope' setting on ST or GF device
x LT	Multiple of LT or overload current setting
x Ie	Multiple of ST or timed short-circuit current setting
x In	Multiple of breaker current rating
x CT	Multiple of installed sensor rating (In IEC EntelliGuard types =In)
RELT	Reduced instantaneous
MCR	Making current release
HSIOC	Hi set instantaneous protection



## Time current curves (cold state)

Example of full time current curve

### Time current curve

The EntelliGuard electronic trip unit has many sophisticated setting features and an extremely broad setting range. On request we can provide complete time current curves covering all installed protection devices. The curves can be produced for any current setting within the range of the installed protection devices, for one or for a combination of two breakers. Please contact your local GE sales office for more information.

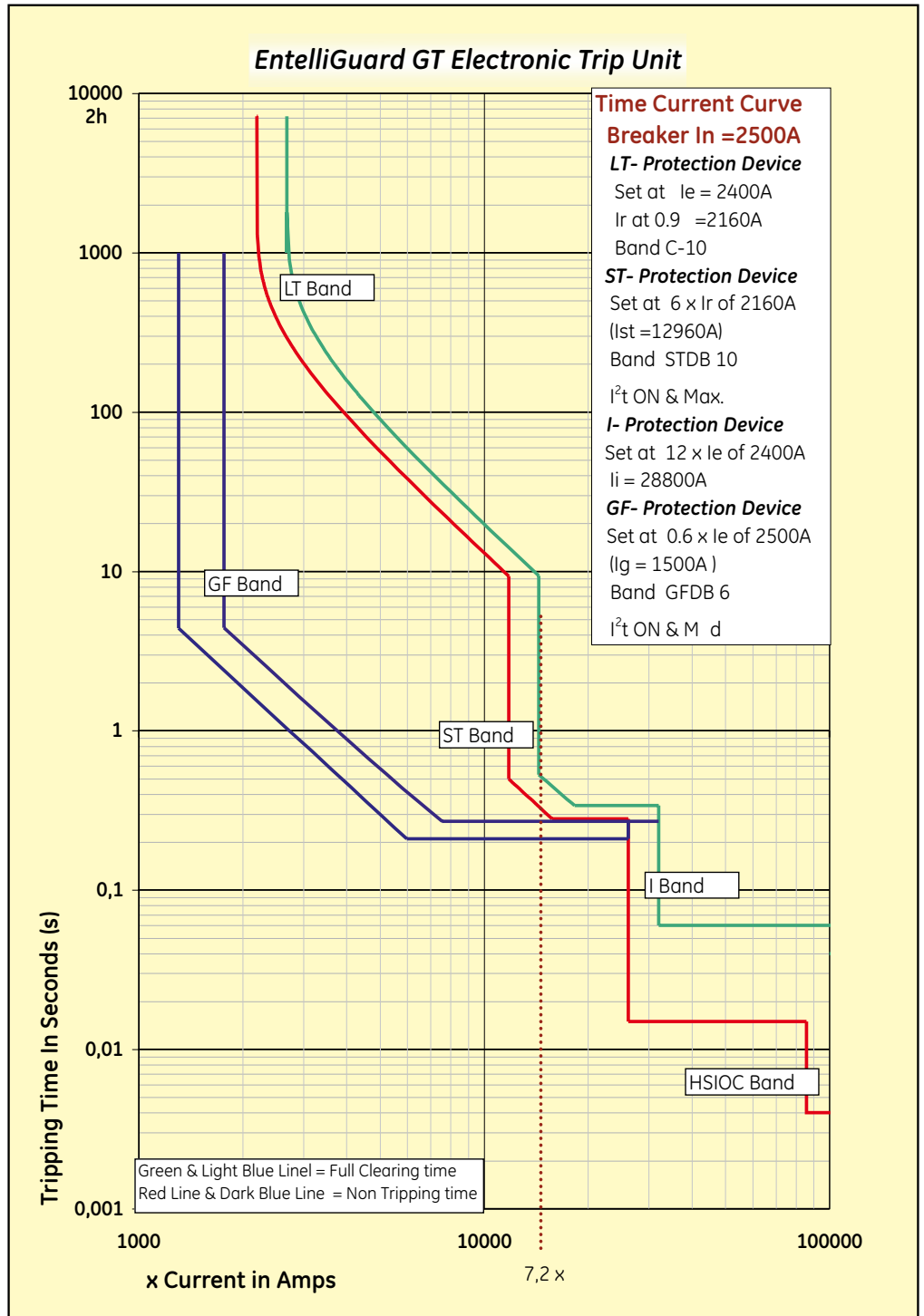



## Breaker accessories

- C.2 Breaker use and operation
- C.3 Electrical operation of breaker (motor operator)
- C.4 Shunt and undervoltage releases; time delay module for undervoltage release
- C.5 Interlock devices, indication contacts and number of devices
- C.6 Auxiliary contacts
- C.7 Bell alarm, cassette position, spring charged and ready to close indication contacts
- C.8 Mechanical Interlocking of multiple breakers
- C.9 Locking provisions for breaker and cassette door-interlock systems; misinsertion device
- C.10 Installation accessories
- C.11 Earthing device (maintenance accessory) spare parts

## Breaker accessories

Application guide

Wiring diagrams

Dimensions

Numerical index

The breaker

Order codes

Electronic trip units

Intro

A

B

C

D

E

F

X



## Breaker use and operation



Indicated Breaker is of a fixed pattern and equipped with Trip Unit

### A power circuit breaker

EntelliGuard is operated by a stored energy mechanism that can be charged either manually or electrically. To charge manually a handle ① is used to 'load' the springs in the mechanism, 10 pumping movements being required. During charging a spring status indicator ② clearly indicates if the breaker is CHARGED (red), CHARGING (yellow), or DIS-CHARGED (green).

After charging is complete, the ready to close indicator ③ indicates that the device can be turned ON and OFF<sup>(1)</sup> by the ON/OFF buttons (④ & ⑤) on the breaker front facia. On the frames 1, 2 & 3 a padlocking mechanism ⑥ is present for up to three locks to lock the breaker in "OFF" position.

On the frame T an accessory ⑪ is available that, when used, allows the of uses of two kinds of keylock or a padlock to lock the device in its 'OFF' position.

An electrical charging mechanism negates the need for loading the springs manually and allows remotely located push-buttons to be used to switch ON & OFF (see page C.3).

The contact position indicator ⑦ on the breaker front provides the user with the correct status of the breaker be it OFF or ON. This indicator is linked to the mechanism and contact system in a manner that allows the device to be used as a disconnecter and

to meet the 'Positive Contact Indication' requirements.

The breaker mechanism is of the trip free type and has an integrated anti-pumping system.

On the frames 1, 2 & 3 the front facia also includes room for an optional key interlock device ⑧ that prevents the breaker from being closed.

On the frame T an accessory ⑪ is available that, when used, allows the of uses of two kinds of keylock or a padlock to lock the device in its 'OFF' position.

The breaker can be equipped with up to four factory or field mountable releases, 1 x closing coil and a combination of shunt and undervoltage releases being possible. The presence of these releases is made visible on the facia by the use of 4 indicator windows ⑨.<sup>(2)</sup>

EntelliGuard power circuit breakers are available in two patterns, fixed and draw-out. A fixed device is bolted to a substructure or wall and the power connections are directly fixed to the breaker. A draw-out device has a cassette that is mounted and connected separately.

A fixed breaker requires the connection and fixation to be removed to replace the breaker.

A breaker in draw-out pattern is supplied as a moving portion, that easily slides in and out of the separately fixed and connected cassette.

*Each standard device is supplied with 3 NO and 3 NC potential free auxiliary contacts. A IP31 front panel with door escutcheon seal and a IP20 terminal strip or plug ⑩ with 39 connection points to wire out accessories.*

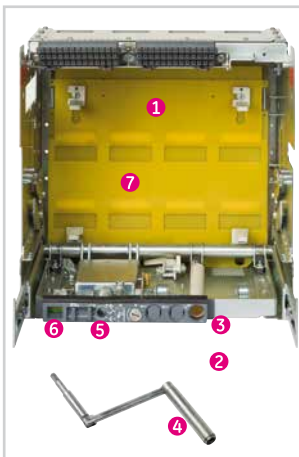

### Draw-out pattern cassette

To dismount a EntelliGuard in the fixed pattern it is required that the power supply is turned off and the connections are removed. A breaker in the draw-out pattern can be quickly and efficiently removed from the system without disconnecting the power supply or removing the connections.

The draw-out system allows easy and simple access to the breaker and its components and enables the user to fully

disconnect the power from the installation for maintenance purposes. Access to the breaker being required for periodic checks and some very limited maintenance allowing the device to be used over its full life span.

The cassette ① is mounted and connected separately and the EntelliGuard breaker is supplied as a moving portion that is easily inserted into the cassette. A racking handle ② is stored within an aperture ③ in the cassette. After removing and unfolding the racking handle and disengaging the blocking mechanism ④, the handle can be inserted into the 'racking' aperture ⑤.

By rotating the racking handle clockwise to move the moving portion inwards (connect) and anti-clockwise to move outwards, (disconnect) the breaker can be racked into one of three positions:

- CONNECTED** Breaker and cassette are fully operational all contacts are connected.
- TEST** The maincontacts are **not connected**. The auxiliary contacts are **connected**.
- DISCONNECTED** The main and auxiliary contacts are not connected. The breaker is still inside the cassette.

To remove the breaker from the cassette, the racking handle must be removed from the 'racking' aperture.

A position indicator ⑥ provides a positive mechanical indication of the indicated connected, test and disconnected positions. Each EntelliGuard cassette has integrated safety shutters ⑦ that automatically isolate the user from live parts when the moving portion is in disconnect or test position.

Multiple accessories as carriage position switches, mechanical interlocks, a miss-insertion device, IP54 front protection covers<sup>(3)</sup> and key lock devices are available (please refer to the relevant sections in this chapter).

*Each standard cassette is supplied with standard main connections, racking handle, safety shutters and a IP20 terminal socket system with 39 connection points to wire out accessories.*

(1) Independent of the breaker position (tripped or ON) the device always provides sufficient energy to switch the breaker 'OFF'

(2) Four is applicable for the frames 1, 2 & 3, frame T: Three.

(3) Not available on frame T

## Electrical operation of breaker

### Electrical charging mechanism (motor)

In order to charge the stored energy mechanism electrically a motor mechanism is available. The design allows factory or field mounting and is available for the full range of EntelliGuard breakers. It is easily fitted with just three bolts. When the circuit breaker is opened, the mechanism automatically recharges the springs and prepares the breaker for an almost instantaneous reclosure should the need arise. High speed recharging ensures that the springs are fully charged within four seconds. A "Spring Charged" contact that indicates the status of this device is always present. A 2nd 'ready to close' contact is available that indicates that the springs have been recharged and that the breaker can be closed.

The device is available in multiple AC & DC voltages and can be used in a operating frequency of up to two operations per minute. It has a life span equivalent to that of the breaker without maintenance. To switch the EntelliGuard breaker ON & OFF remotely a closing coil and shunt release is necessary.



### Connections

The charging mechanism connection points can be found on terminal A of both the fixed pattern and draw-out breaker types.

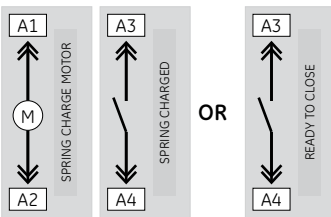

### Electrical characteristics

Control voltage	Motor operator Frame T	Motor operator Frame 1	Motor operator Frames 2 & 3
<b>Power Consumption</b>			
24-30V DC, 48V DC, 60V DC, 110-130V DC, 220 - 250V DC	300W	300W	480W
48V AC, 110-130V AC, 220-240V AC, 380-400V AC, 440V AC	350VA	350VA	560VA

### Closing coil

To switch the power circuit breaker ON remotely a closing coil is available that when energized releases the spring charged closing mechanism.

The device is available as a factory mounted component or as a field mountable device. It is an extremely easy-to-fit, clip-on unit, with simple plug-in connectors.

The coils have a life span equivalent to that of the full breaker life span.



### Command closing coil<sup>(1)</sup>

Alternatively a command closing coil type is available replacing the standard type. This device offers an extended functionality with all the features of the standard device. Additional connections allow this type to be wired out through the trip unit and to be accessed electrically through the communications bus. It is supplied with an extra 'ON' push-button that fits onto the breaker front facia. Fitting between the two existing ON and OFF buttons gives the user an extra electrical 'ON' option locally. The coils can be used in an operating frequency of up to two operations per minute and have a life span equivalent to that of the full breaker life span.

### Connections

The closing coils and command closing coils connection points can be found on terminal A of both the fixed pattern and draw-out breaker types.

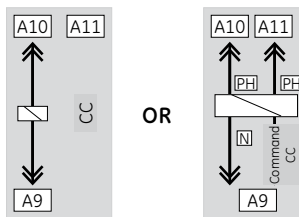

### Electrical characteristics

AC	DC	Power consumption
--	24V	350 VA Inrush
48V	48V	
--	60V	
110-130V	110-130V	
220-240V	220-240V	
277V	250V	
380-415V	--	
440V	--	

(1) The command closing coil is only available with 3NO and 3NC auxiliary contacts for frame T (4NO and 4NC not possible).

## Shunt and undervoltage releases

### Shunt release

A device designed to switch the power circuit breaker OFF remotely. When energized a shunt release instantaneously activates the circuit breaker mechanism thus ensuring a rapid disconnection of the main contacts (50msec).

EntelliGuard shunt releases are available as an impulse or as a continuously rated type. The continuously rated types are designed to be used as a closure prevention device when energized.

The impulse rated types must always be used with a breaker auxiliary contact.

It is possible to fit: a) 2 shunt releases in frame 1/2/3  
b) 1 shunt release in frame T

A third variant, the command shunt trip, allows operation via communications.

The device is available as a factory mounted component or as a field mountable device. It is an extremely easy-to-fit, clip-on unit, with simple plug-in connectors.

The individual devices have a wide voltage range, thus limiting the number of devices needed and have a life span equivalent to that of the full breaker life span.



### Remote reset coil

The remote reset coil is a standard continuously rated shunt release device mechanically linked to the reset mechanism of the breaker. (PMU base)

For resetting remotely using this accessory the knob on the front the trip unit should be set to the manual position.

The device is only available as a factory mounted component.

### Undervoltage release

A device designed to open the breaker contacts and to prevent the breaker from closing when in a 'no volt' condition. On a de-energization the undervoltage release activates the circuit breaker mechanism and ensures a rapid disconnection of the main contacts (50 milliseconds). When not re-energized in accordance to the conditions stated in the IEC 60947 the device prevents the power circuit breaker from closing. The EntelliGuard undervoltage releases are designed to react within a pre-defined voltage band, only reacting when the voltage supplying drops below the limits of this band. To prevent nuisance tripping due to short power interruptions or 'Brown Outs' the device has a built in delay of 50 milliseconds. In the frames 1, 2 & 3 two undervoltage releases can be fitted in the frame T one. A special version with no intentional delay is also available (GUVR240 & GUVR240R).

The device is available as a factory mounted component or as a field mountable device. It is an extremely easy-to-fit, clip-on unit, with simple plug-in connectors.

The individual devices have a wide voltage range, thus limiting the number of devices needed and can be used in an operating frequency of up to two operations per minute. The releases can have a life span equivalent to that of the full breakers life span.

### Connections

The connection points of both releases can be found on terminal A of both the fixed pattern and draw-out breaker types.

In frame T it is possible to mount 1 UVR and 1 ST release. In frames 1, 2 & 3 it is possible to mount a total of three releases, the third being a UVR OR shunt release.

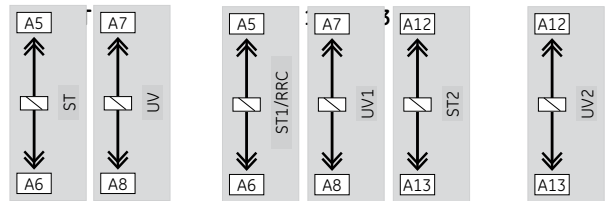

### Electrical characteristics releases

#### Continuously rated shunt releases and undervoltage releases

AC	DC	Power consumption
--	24V	350 VA / 350 W Inrush 60 VA / 50W Holding
48V	48V	
--	60V	
110-130V	110-130V	
220-240V	220-240V	
277V	250V	
380-415V	--	
440V	--	

#### Impulse rated shunt releases

AC	DC	Power consumption
24V	24V	480 VA / 480 W Inrush
110-130V	110-130V	
220-240V	220-240V	

### Time delay module

The de-energizing operation of the Undervoltage release can be delayed. This optional, externally mounted module has an adjustable time delay of zero to three seconds. The device can be implemented to prevent undesired breaker tripping due to momentary voltage interruptions and is connected in series with the undervoltage release.

Optionally, the EntelliGuard trip unit can be supplied with a three phase plus neutral undervoltage protection device that can



provide a power interruption alarm and/or initiate a breaker 'trip'.

### Electrical characteristics releases

AC	DC	Power consumption
48V	--	350 VA Inrush 60 VA Hold
--	48V	
--	60V	
110-130V	--	
--	110-130V	
220-240V	--	
--	250V	
250-277V	--	
380-415V	--	
440V	--	

## Interlock devices, indication contacts and number of devices

### Network interlock device<sup>(1)</sup>

When devices as the EntelliGuard power circuit breaker are used in automatic or manual power transfer systems, local access and operation of the device can be undesirable. The network interlock device is an optional mechanical lockout device that can be added to electrically operated circuit breakers. It is a logic driven interlock with two positions, LOCKOUT and RESET. The network interlock is locked out and reset by means of voltage pulse applied across respective terminals.<sup>(1)</sup>

Setting the network interlock to LOCKOUT when the breaker is closed causes the breaker to trip. In the LOCKOUT position, the network interlock holds the breaker mechanically trip free and also inhibits electrical closing. A command to reset the network interlock must be provided before the breaker can be closed manually or by control logic. Loss of control power does not cause the network interlock to reset. The network interlock can also RESET by pushing the reset button provided on the front face of accessory.

The device is available as a factory mounted component and has the volume of two releases (shunt/undervoltage).

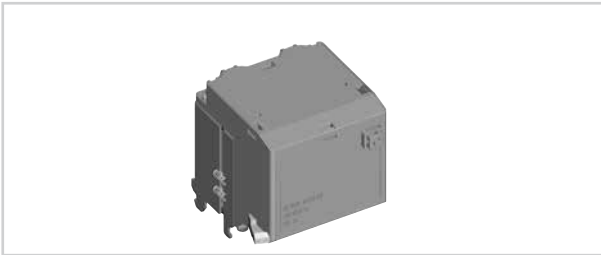

### Connections

The device replaces 1 shunt and 1 undervoltage release and is wired out to the same connection points located on terminal A of both the fixed pattern and draw-out breaker types.

### Number of devices

In frame T it is possible to mount 1 UVR and 1 ST release and one closing coil (in three locations).

In frames 1, 2 & 3 it is possible to mount a total of three releases, the third being a UVR **OR** shunt release, and one closing coil (in four locations).

Shunt release (shunt), closing and command closing coils (CC/CCC) and undervoltage releases (UVR) can be mounted in the following combinations. The network interlock device as described above takes 2 of the indicated 4 spaces.

### Frame T

Combination	Coil position on front facia, from left		
	1	2	3
A	Shunt	CC/CCC	UVR

### Frames 1, 2 and 3

Combination	Coil position on front facia, from left			
	1	2	3	4
A	Network	Interlock	CC/CCC	UVR
B	Shunt/RRC	UVR	CC/CCC	Shunt
C	Shunt/RRC	UVR	CC/CCC	UVR
D	Network	Interlock	CC/CCC	Shunt

### Release indication contacts<sup>(2)</sup>

To indicate, if a shunt or an undervoltage release initiation has resulted in a breaker, OFF or TRIP, a contact can be fitted to the releases. The contacts are available in two versions; one power rated for use in standard circuits and a second signal rated type for use with the electronic trip unit communication option.

The contacts are available as a factory mounted component or as a field mountable device. They are extremely easy-to-fit, clip-on units, with simple plug-in connectors.

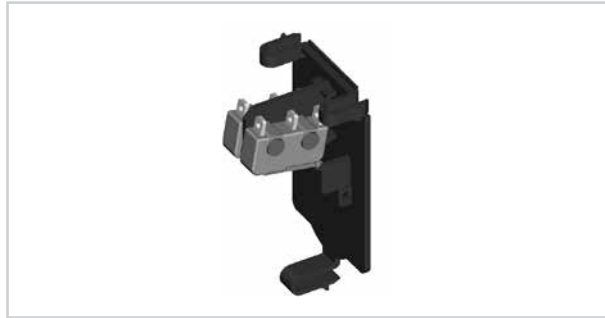

### Connections

The connection points of the power rated contacts can be found on terminal B of both the fixed pattern and draw-out breaker types<sup>(3)</sup>. The Signal rated types are connected to the electronic trip unit and are only accessible through the optional communication option.

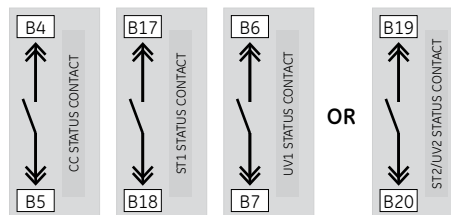

### Electrical characteristics

#### Power rated types

AC ratings		DC ratings	
Voltage	Amps	Voltage	Amps
250V	AC21-6A	125V	DC21-0.4A
		250V	DC21-0.2A

Minimum operating current 0.16 A at 5V DC

#### Signal rated, gold plated contact types

AC ratings		DC ratings	
Voltage	Amps	Voltage	Amps
125V	AC21-0.1A	8-30V	DC21-0.1A

Minimum operating current 1mA at 5V DC

(1) The network interlock device is only available in frames 1, 2 & 3

(2) The release indication contacts are only available in frames 1, 2 & 3

(3) The use of these devices limits the wiring out of some auxiliary contacts (see section E for full schematics)

## Auxiliary contacts

### Auxiliary contacts

Auxiliary contacts are designed to indicate the position of the power circuit breaker main contacts. Each EntelliGuard device is supplied with a standard package of 3 normally open (NO) and 3 normally closed (NC) contacts that operate simultaneously with the breakers main contacts. Optionally other packages are available that can be used to increase the number of available contacts by replacing the standard auxiliary contact block.

### Auxiliary contact packages

- Power rated contacts 4 NO & 4 NC<sup>(1)</sup>
- Power rated contacts 8 NO & 8 NC<sup>(2)</sup>
- Power rated contacts 3 NO & 3 NC plus  
Signal rated contacts 2 NO & 2 NC<sup>(2)</sup>
- Power rated contacts 4 NO & 4 NC plus  
Signal rated contacts 4 NO & 4 NC<sup>(2)</sup>

The devices are available as factory mounted components or as a field mountable device. Auxiliary contact packages are easy-to-fit, and have simple plug-in connectors.

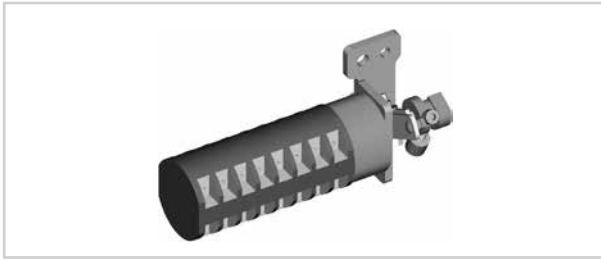

### Connections

The connection points of the auxiliary contacts can be found on the two terminals (A & B) of both the fixed pattern and draw-out breaker types.

### Electrical characteristics auxiliary contacts

#### Power rated types

AC ratings		DC ratings	
Voltage	Amps	Voltage	Amps
110-130V	AC21 - 15A	24V	DC21 - 15A
	AC23 - 10A		
220-240V	AC21 - 10A	110-130V <sup>(3)</sup>	DC21 - 10A
	AC23 - 5A		
380-440V	AC21 - 5A	250V <sup>(4)</sup>	DC21 - 5A
	AC23 - 2.5A		

Minimum operating current 0.1A at 8V DC

#### Signal rated, gold plated contact types

AC ratings		DC ratings	
Voltage	Amps	Voltage	Amps
250V	AC21-0.1A	8-30V	DC21-0.1A

Minimum operating current 10mA at 5V DC

- (1) The 4NO & 4NC auxiliary contacts are only available in frame T
- (2) These devices are only available in frames 1, 2 & 3, and limits the wiring
- (3) Three contacts in series
- (4) Six contacts in series
- (5) Cannot be used in combination with a command close coil

### Connections

The connection points of auxiliary contacts can be found on the auxiliary disconnect terminal of both the fixed pattern and draw-out breaker types.

#### Frames 1, 2 & 3

- Power rated contacts 3NO & 3NC
- Power rated contacts 8NO & 8NC
- Power rated contacts 3NO & 3NC (NO (or C) 1,2 & 3)  
plus signal rated contacts 2NO & 2NC (NO (or C) 4 & 5)
- Power rated contacts 4NO & 4NC (NO (or C) 1,2,3 & 4)  
plus signal rated contacts 4NO & 4NC (NO (or C) 5,6,7 & 8)

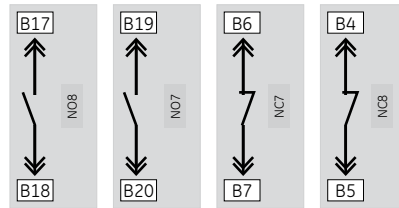
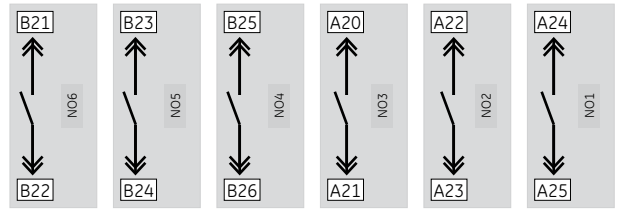
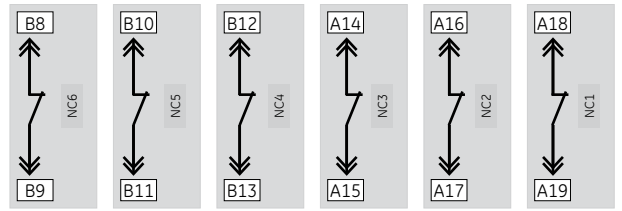

#### Frame T

- Power rated contacts 3NO & 3NC
- Power rated contacts 4NO & 4NC<sup>(5)</sup>

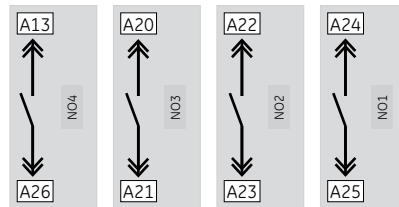
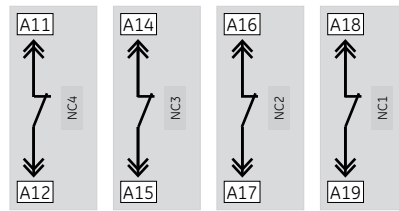

## Bell alarm, cassette position indication, spring charged and ready to close contacts

### Bell alarm contact

When an EntelliGuard power circuit breaker has tripped due to a fault detected by the tripunit, a bell alarm changeover contact is available to indicate this. The electronic trip units trip reason indicators and the optional release indication contacts then providing the reason of the 'trip'. The device is available with power rated or signal rated contacts and are available as a factory mounted component or as a field mountable device. The bell alarm contact is easy-to-fit, and has simple plug-in connectors. The contact can only be used when the knob on front of the trip unit is set to the manual position.

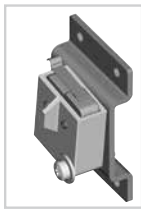
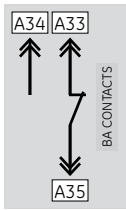

### Connections

The connection points of the bell alarm contact can be found on terminal A of both the fixed pattern and draw-out breaker types.

### Electrical characteristics bell alarm contact

AC ratings		DC ratings	
Voltage	Amps	Voltage	Amps
250V	AC21-6A	125V	DC21-0.4A
		250V	DC21-0.2A

Minimum operating current 0.1A at 8VDC

### Signal rated, gold plated contact types<sup>(1)</sup>

AC ratings		DC ratings	
Voltage	Amps	Voltage	Amps
125V	AC21-0.1A	8-30V	DC21-0.1A

Minimum operating current 0.1mA at 5V DC

### Cassette position indication contacts

A breaker in draw-out mode has a cassette that is used for mounting and connecting. The breaker, in its moving portion mode, can be inserted into the cassette and by use of the racking handle and it can be moved to one of three positions:

### Connected, Test, Disconnected or Withdrawn

To indicate in which position the EntelliGuard breaker is located within the cassette position is Indication contacts are available. The disconnected position is only being indicated when minimum isolating distances between contacts on both the main and auxiliary circuits have been achieved. The devices are available in two packages with 1 or 2 changeover contacts per position.



Commonly referred to as carriage switches they are available as a factory mounted component or as a field mountable device.

### Connections

The device is located in the left side of the cassette substructure and can be accessed and connected directly.

### Electrical characteristics position indication contacts

AC ratings		DC ratings	
Voltage	Amps	Voltage	Amps
250V	AC21-10A	125V	DC21-0.5A
		250V	DC21-0.25A

### Spring charged and Ready to close contacts

A breaker with electrical charging mechanism can be optionally equipped with one or two indication contacts. The first the Spring charged contact simply does as indicated and is supplied with the standard Motor Operating Mechanism. The second, the ready to close indication, optionally replaces the Spring charged contact. It only moves position when the following conditions are met:

- > The circuit breaker is open
- > The closing springs are charged
- > The circuit breaker is not locked/interlocked in open position
- > There is no standing closing order
- > There is no standing opening order

Both contacts are available in a 1NO configuration.

### Connections

The connection points of these contacts can be found on terminal A of both the fixed pattern and draw-out breaker types

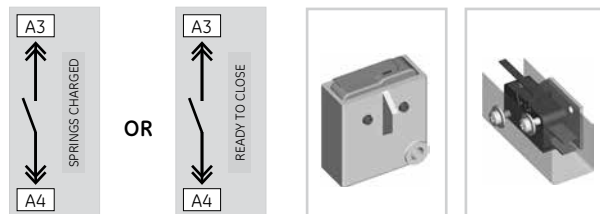

### Electrical characteristics

#### Power rated types

AC ratings		DC ratings	
Voltage	Amps	Voltage	Amps
250V	AC21-6A	125V	DC21-0.4A
		250V	DC21-0.2A

Minimum operating current 0.16A at 5V DC

#### Signal rated, gold plated contact types<sup>(1)</sup>

AC ratings		DC ratings	
Voltage	Amps	Voltage	Amps
125V	AC21-0.1A	8-30V	DC21-0.1A

Minimum operating current 1mA at 5V DC

(1) Spring charged contact NOT available in signal rated version



## Mechanical interlocking of multiple breakers

### Mechanically interlocked breakers<sup>(1)</sup>

Many low voltage installations have multiple power sources that are used in many different configurations. The power sources are required to supply the installation simultaneously, alternatively or in a certain logical combinations of both.

The EntelliGuard power circuit breaker can be used to protect these power supplies and be electrically and mechanically interlocked to provide the necessary logic. The mechanical interlocks are available for fixed and draw-out circuit breakers, enabling the direct interlocking of the breakers, mounted side by side or stacked.

The device has two parts; the first a kit customized for use with the breaker in fixed pattern or the cassette when a draw-out pattern is required (field mountable). Two or more specially designed field mountable cables available in lengths of 1.0; 1.6; 2.0; 2.5; 3.0; 3.5 and 4.0 meters being the second.



Any combination mode (fixed or draw-out), current rating, number of poles or frame size<sup>(1)</sup> can be interlocked. The interlocking systems are available in one configuration for 2 breakers and in three others for 3 breakers.

### Two Breaker Interlock

Interlock type A in which one of the two breakers (B1 or B2) can be switched ON. Each breaker must be equipped with a factory mounted interlock type A. Two cables are needed.

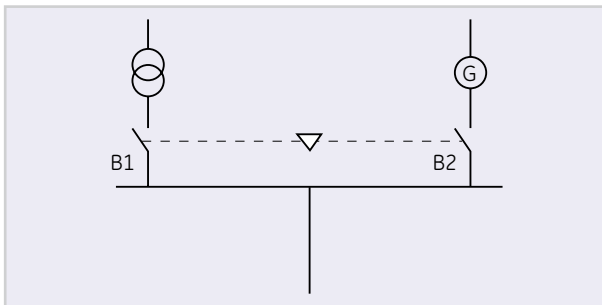

### Three breaker interlock type B

Interlock type B in which one of the three breakers (B1, B2 or B3) can be switched ON. Each breaker must be equipped with a factory mounted interlock type B. Six cables are needed.

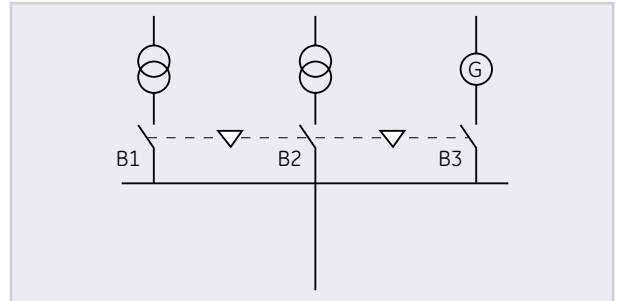

### Three breaker interlock type C

Interlock type C in which one or two of the three breakers can be switched ON in accordance with the inserted diagram. Each breaker must be equipped with a factory mounted interlock type C. Six cables are needed.

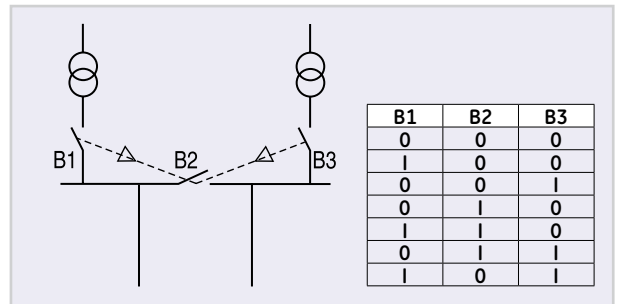

### Three Breaker Interlock type D

Interlock type D in which one or two of the three breakers can be switched ON in accordance with the inserted diagram. Breakers B1 & B3 must be equipped with a factory mounted interlock type A and B2 with a interlock type D. Four cables are needed.

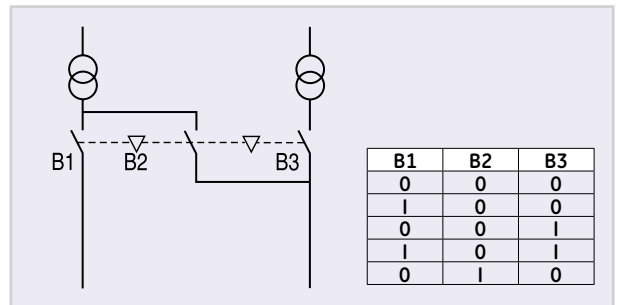

(1) For frame T, only the combination in the same frame size can be interlocked.



## Locking provisions for breaker and cassette door-interlock systems; misinsertion device

### Standard padlocking facilities Breaker and cassette

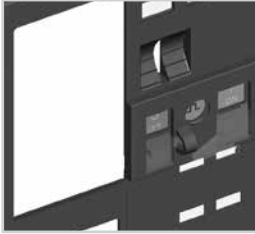

EntelliGuard power circuit EntelliGuard frames 1, 2 & 3 breakers in fixed and draw-out pattern have a standard padlocking facility. For one padlock of 5-8mm allowing the breaker to be locked in it's "OFF" position.

For the frame T an accessory is available allowing the breaker to be locked in it's "OFF" position. This by a keylock or padlock of 5-8mm.

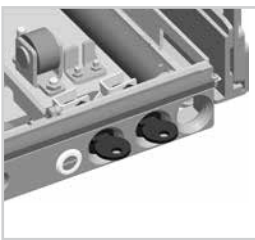

For all frames, the cassette supplied with the breakers in draw-out mode has three facilities for up to 3 padlocks<sup>(1)</sup> of 5-8 mm. Two of these can be found on the cassette euchenon and can be used for locking the shutters in closed position or closing and locking the racking

handle aperture. The third option is located on the breaker draw-out support slides and can be used to lock breaker and chassis combination in disconnected position.

### Facia push-button padlocking facilities



To prevent un-authorized access to both the ON and OFF push-buttons on the breakers front facia, a padlockable push-button cover can be fixed to the breaker front facia. 1 padlock of 5-8mm can be used.

### Breaker key lock facilities



A power circuit breaker can be equipped with key locks. The key lock system encompasses a device fitted in the front facia allowing the locks to be fitted and the separate locks. These devices ensure that a circuit breaker

cannot be closed unless the key has been inserted and secured within the lock.

For frames 1, 2 & 3 devices are available for 1 Castell or Kirk lock or 4 Ronis 1104 or 4 Profalux locks.

For frame T, devices are available for 1 padlock and one Ronis 1104 or Profalux lock.

The separate Ronis and Profalux locks are part of the EntelliGuard product offering, but padlocks and the Castell and Kirk locks must be acquired elsewhere.

(1) Shutter lock, maximum 1 padlock of 3-8mm.

(2) The frame T cassette can be equipped with maximum one Ronis or Profalux key locks

### Cassette key lock facilities<sup>(2)</sup>

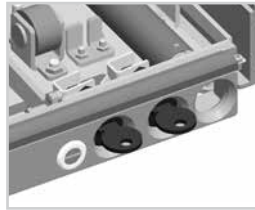

The cassette of a power circuit breaker can be equipped with up to two Ronis or Profalux key locks. The key lock system encompasses a device fitted to the cassette allowing the locks and the separate locks to be fitted. The device ensures that a

draw-out circuit breaker cannot be moved from the TEST or DISCONNECT position unless the key has been inserted and secured within the lock. The locks also prevent the breaker from (all positions) being switched on.

The device allows up to 2 Ronis 1104 or Profalux locks. The locks must be purchased as separate items.

### Door interlock



A device designed to prevent the door of the equipment in which the breaker is installed to be opened when the power circuit breaker is in connected position. It is available in two executions; one for a door opening to the left and one to the right.

### Misinsertion device

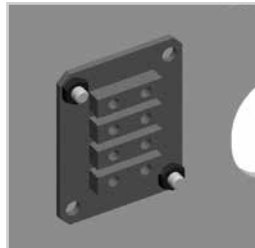

By incorporating this optional security interlock device into the draw-out cassette, an inadvertent insertion of an incorrect rated moving portion is prevented. Before using the interlocking system, the misinsertion logic needs to be set on both the breaker and the device.

## Installation accessories

### Operations counter

A simple and easy to install mechanical device that displays an accurate and cumulative record of the number of closing operation of the EntelliGuard power circuit breaker in which it is installed.



The mechanical and electrical life span of the breaker can be extended by limited periodic maintenance. The counter contains information that can assist in determining when.

### Contact wear indicator<sup>(1)</sup>



A second simple and easy to install mechanical device that can be used to ascertain when breaker maintenance is needed. Mounted above the contacts of a breaker in draw-out mode it allows the user to physically see the contacts and contains markers to determine their wear.

### Sensors, Rogowski coils

If the EntelliGuard electronic trip unit is configured to allow earth/ground fault protection an external neutral sensor can be required. Rogowski coils for this application are available as separate items and are supplied with a mounting kit.



For the correct sensor choice and application details see page B.13-B.15 of this catalogue.

### Sensors, current transformers

If the EntelliGuard electronic trip unit is configured to allow earth/ground fault protection an external neutral sensor can be required. In most standard applications a Rogowski coil suffices, however in some cases other sensors are needed. Current transformer are used for 'Source Ground' return earthfault applications. If combinations of earthfault options as UEF, REF & SEF are required multiple sensors could be required.

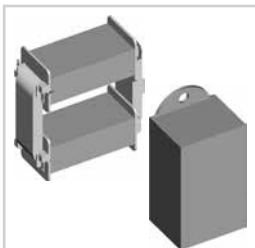

Current transformers for these application are available as separate item and are supplied with a mounting kit and an extra interposing current transformer needed in some specific cases. For the correct sensor(s) choice and application details see page B.13-B.15 of this catalogue.

(1) Not available in frame T.

### Wall mounting brackets<sup>(1)</sup>

EntelliGuard power circuit breakers are designed to be mounted within a frame inside a low voltage distribution or control panel. In some cases, specifically when the front connection option is used, wall mounting can be more expedient.



For this purpose wall mounting brackets are available for the breakers in fixed pattern, frames 1 and 2.

### Terminal block

Breakers in fixed pattern, cassettes and breakers in draw-out mode are always supplied with an auxiliary connection block suitable for 39 connection points (terminal A). When the number of factory installed accessories exceeds the available number of connection points needed, a 2nd connection block is automatically added.

- Frames 1, 2 & 3: 39 pole Block B
- Frame T: 16 pole Block C



For cases where the accessories are mounted in the field, separate auxiliary connection block are available.

- Frames 1, 2 & 3: A 78 block A plus B terminal for the fixed pattern and a 39 pole extra block B for breakers in draw-out pattern.
- Frame T: A 16 pole Block C for all patterns

### IP54 cover<sup>(1)</sup>



All power circuit breakers are supplied with a door flange/door frame that allows the user to finish the door cut-out professionally, simultaneously providing a protection degree of IP31. If a higher protection degree is required, an additional cover is available allowing IP54.

### Hoisting/lifting accessories



All EntelliGuard protection devices are equipped with a set of hoisting eyes (see page D.2). To use these hoisting eyes with standard lifting equipment specifically designed adaptors are available.

All EntelliGuard frame T types are supplied with handling racks. (see page D.2)  
For the frames 1, 2 & 3 lifting beams are available. One adaptor or beam is available for use with frames 1 & 2 (GLB1) and a second for use with the larger frame 3 breaker (GLB3).

## Earthing device (maintenance accessory) spare parts

### Earthing device<sup>(1)</sup>

To allow either the incoming cables or the busbar to be safely held at earthed potential and locked during system maintenance, all EntelliGuard power circuit breakers can be fitted with an earthing device. The device is available as a separate field mountable accessory and has a short-circuit rating equal to the short time withstand (Icw) of the breaker.

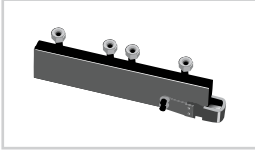

### Spare parts for general use

The EntelliGuard power circuit breaker uses components that are designed to last the full life span of the device. However, certain components can be damaged or break during operational use. For these specific cases, the following spare parts are available:

Cassette: moving portion racking handle **(A)**  
shutters **(B)**

Breaker **(C)**: front cover

Locking devices: set of 4 Ronis key interlock cams

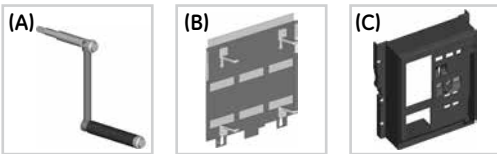

### Spare part for maintenance purposes

Air circuit breakers as the EntelliGuard power circuit breakers require periodic maintenance. Here, in some cases certain components critical to the devices functionality could need replacement.

Please contact our service department for specialist assistance in establishing which components need replacement and the physical replacement activities.

The following items are available:

Arc chutes **(A)**

Fixed arcing contacts **(B)**

Cassette cluster contacts **(C)**

Pliers to remove cassette cluster contacts **(D)**

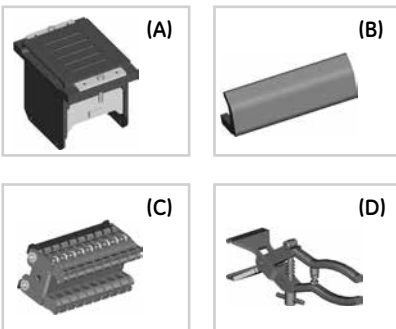

(1) Not available in frame T.

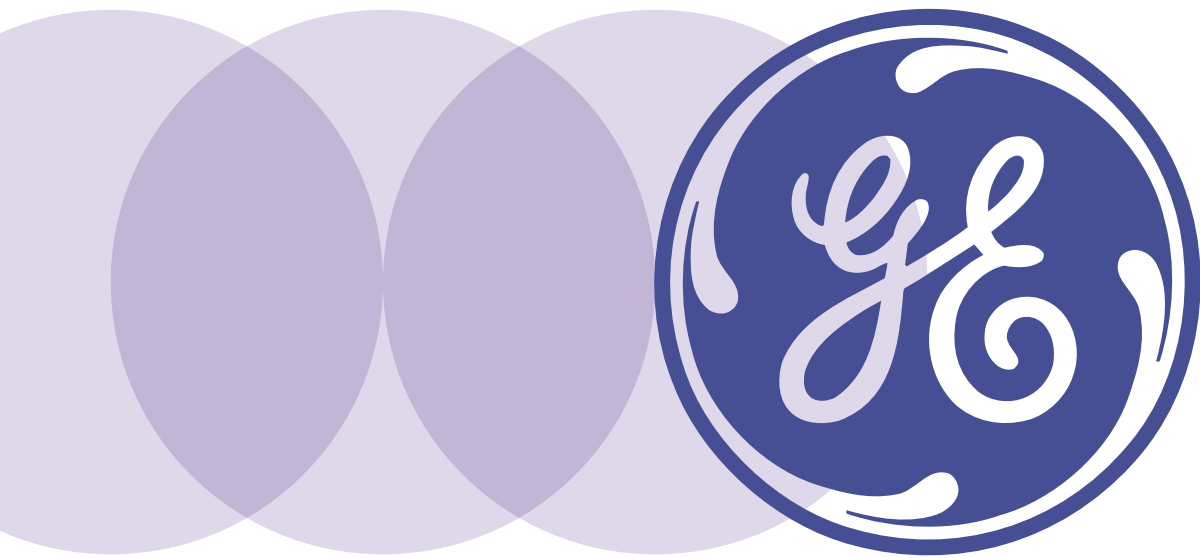

**Application guide**

- D.2 Handling, mounting and connecting
- D.4 Heat dissipation, Watt loss and current ratings at temperatures >50°C
- D.6 Selectivity/Discrimination
- D.7 Selectivity with downstream devices, tables
- D.8 Protection of standard circuits
- D.9 Applications
- D.10 Environmental considerations

The breaker

Order codes

Electronic trip units

Breaker accessories

**Application guide**

Wiring diagrams

Dimensions

Numerical index

Intro

A

B

C

**D**

E

F

X



## Handling, mounting and connecting

### Clearance distances

A modern circuit breaker is designed to interrupt high short-circuit currents in a very limited time frame. In doing so the breaker vents gas and a limited amount of conductive fragments.

EntelliGuard power circuit breakers have been designed to limit the venting phenomenon to a minimum, but certain clearances do need to be taken into account as indicated in the front and side views.

The maintenance of the fixed pattern devices requires access to the contacts and the removal of the arc chutes. A certain distance needs to be left above the breaker to allow for this as indicated in the front and side views.

### Front view fixed or draw-out pattern

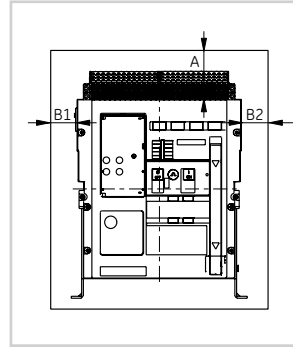

### Side view fixed pattern

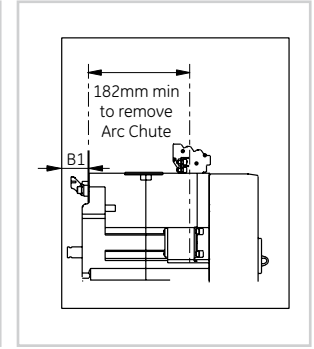

Minimum clearance distances on fixed pattern breaker from housing to:		
	Metal parts	Insulated parts
A <sup>(1)</sup>	160	160
B1	30	30
B2	30	30

Minimum clearance distances from draw-out cassette housing to:		
	Metal parts	Insulated parts
A	0	0
B1	30	30
B2	30	30

(1) Dimension allows for field arc chute replacements

### Handling

EntelliGuard frame T breakers in the fixed pattern and draw-out patterns are provided with the lifting racks.

To handle the breaker attach the racks between the 2 holes lifting eyes.

EntelliGuard frames 1, 2 & 3 breakers in the fixed pattern and draw-out portion have two retractable lifting eyes. One of these is located on the breaker right hand side and a 2nd on the left (see sketch).

The cassettes have four re-enforced tilting points with M10 screw thread.

### Frame T

#### Side view fixed or draw-out type



### Frames 1 & 2 & 3

#### Side view fixed or draw-out type

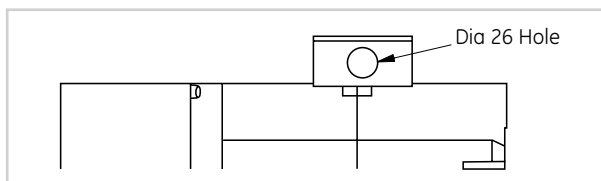

### Recommended connection cross sections

The adjacent table indicates the recommended bus bar dimensions to be used in connecting the EntelliGuard power circuit breaker. The current ratings of the devices with these recommended bus bar connection sizes are indicated on page D.3 & D.4.

Breaker type 'automatic'	Switch type 'non automatic'	Frame	In in A	Recommended copper busbar sizes
GT04R & K	G704R	T		2 x 30 x 5
GG04, S N & H	GJ04S & GW04N	1 or 2	400	1 x 40 x 10 or 1 x 80 x 5 or 2 x 40 x 5
GG04 E and M	GJ04H			
GT07R & K	G707R	T		2 x 40 x 5
GG07S, N & H	GJ07S & GW07N	1 or 2	630	1 x 50 x 10 or 1 x 100 x 5 or 2 x 50 x 5
GG07 E and M	GJ07H			
GT08R & K	G708R	T		2 x 40 x 5
GG08S N & H	GJ08S & GW08N	1 or 2	800	1 x 50 x 10 or 1 x 100 x 5 or 2 x 50 x 5
GG08 E and M	GJ08H			
GT10R & K	G710R	T		3 x 40 x 5
GG10S, N & H	GJ10S & GW10N	1 or 2	1000	1 x 50 x 10 or 2 x 60 x 5
GG10 E and M	GJ10H			
GT13R & K	G713, R & K	T		4 x 40 x 5
GG13S N & H	GJ13S & GW13N	1 or 2	1250	2 x 40 x 10 or 2 x 80 x 5
GG13 E and M	GJ13H			
GT16R & K	G716R	T		4 x 50 x 5
GG16S, N & H	GJ16S & GW16N	1	1600	2 x 50 x 10 or 2 x 100 x 5
GG16 E and M	GJ16H	2		
GG20, S N & H	GJ20S & GW20N	1	2000	3 x 50 x 10 or 3 x 100 x 5
GG20 E and M	GJ20H	2		
GG25N, H & M	GJ25N & GW25H	2	2500	4 x 50 x 10 or 4 x 100 x 5
GG25S & GG25F	GW25F & GJ25S	1	2500	4 x 50 x 10 / 4 x 100 x 5
GG32N, H & M	GJ32N & GW32H			
GH32N, H & M	GK32N & GZ32H	2 or 3	3200	4 x 100 x 10
GG32G & L	GJ32G			
GG40N, H & M	GJ40N & GW40H	2	4000	4 x 100 x 10 Plus 1 x 100 x 5
GH40N, H & M	GK40N & GZ40H			
GG40G & L	GJ40G	3	4000	4 x 100 x 10
GG50M & L	CJ50L	3	5000	5 x 120 x 10 or 6 x 100 x 10
GG64M & L	CJ64L	3	6400	7 x 120 x 10 or 8 x 100 x 10

## Handling, mounting and connecting

### Frame T connection modes and application

**Fixed pattern**

R&K type 400-1600A Rear horizontal

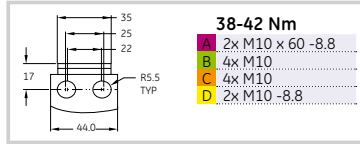

**Fixed pattern**

R&K type 400-1600A Rear vertical

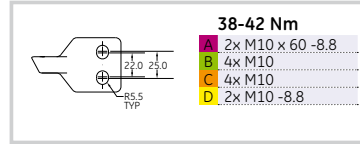

**Fixed pattern**

R&K type 400-1600A Front

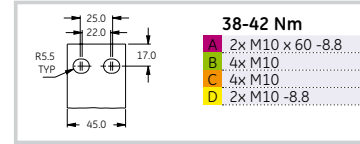

**Draw-out pattern**

R&K type 400-1600A Rear horizontal or vertical

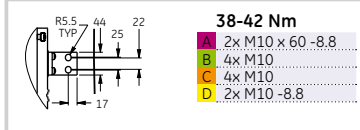

**Draw-out pattern**

R&K type 400-1600A Rear horizontal

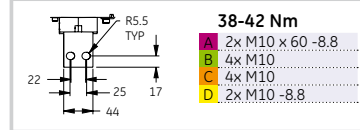

**Draw-out pattern**

R&K type 400-1600A Front

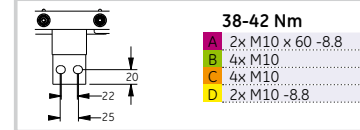

### Frame 1 connection modes and application

**Fixed pattern**

S type 400-1600A Rear horizontal

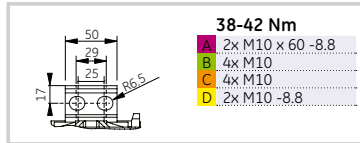

**Fixed pattern**

400-2000A Rear vertical

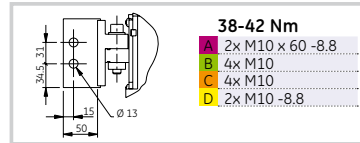

**Draw-out pattern**

S type 2000A, N & H 400-2000A

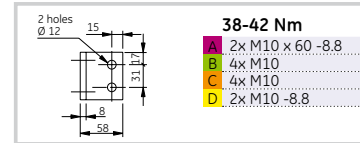

**Fixed pattern**

N & H type 400-1600A Rear horizontal

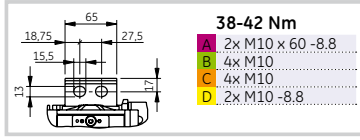

**Fixed pattern**

400-2000A Front

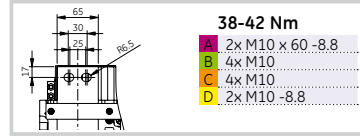

**Draw-out pattern**

400-1600A Front

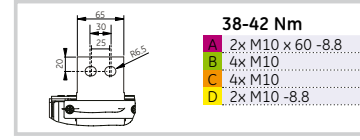

**Fixed pattern**

2000A Rear horizontal

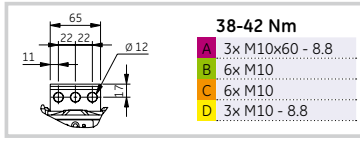

**Draw-out pattern**

S type 400-1600A Rear vertical or horizontal

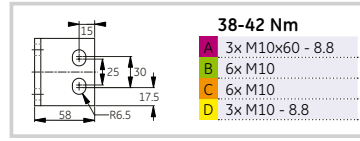

**Draw-out pattern**

2000A Front

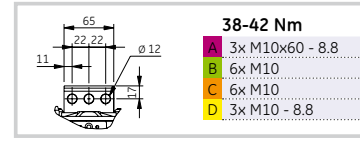

### Frame 2 connection modes and application

**Fixed pattern**

400-4000A Rear horizontal or vertical

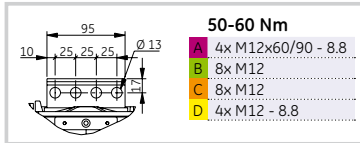

**Draw-out pattern**

400-3200A Rear vertical or horizontal

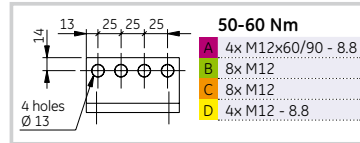

**Draw-out pattern**

400-4000A Front

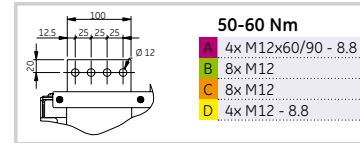

**Fixed pattern**

400-4000A Front

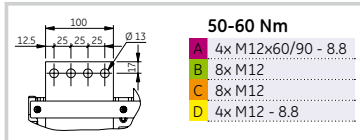

**Draw-out pattern**

4000A Rear vertical ONLY

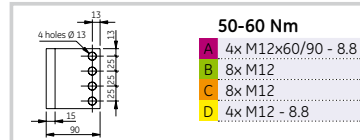

**Draw-out pattern - enhanced thermal rated version**

3200 & 4000A Rear vertical ONLY

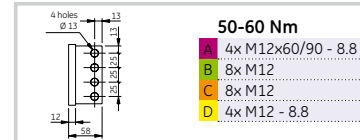

### Frame 3 connection modes and application

**Fixed pattern**

4000-5000A Rear horizontal

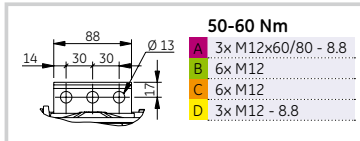

**Draw-out pattern**

4000-5000A Rear horizontal -OR- 4000-6400A Rear vertical<sup>(1)</sup>

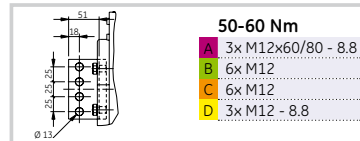

**Fixed pattern**

4000-6400A Rear vertical

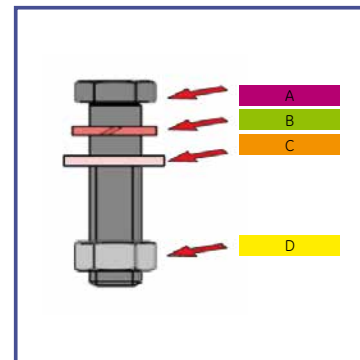
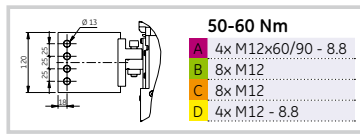

(1) The frame 3 draw-out pattern construction has two connection pads per connection point.

Use a torque of 40 Nm when putting terminals on rear of cassette



## Heat dissipation, Watt loss and current ratings at temperatures >50°C

### Use

An enclosure manufacturer can provide the exact data on the allowable power dissipation within a certain enclosure. The values depend on the enclosure type, the ventilation it offers and where the components are located within this enclosure.

For most recent heat dissipation values, please contact GE

### EntelliGuard power circuit breakers

The devices have been designed to offer the lowest, feasible heat dissipation value and the highest possible current ratings when enclosed. The tables here indicate the heat dissipation values and current ratings at temperatures within the direct vicinity of the breaker in free air. The values apply for breakers used with rear connections and the preferred vertical busbars. The recommended connection cross sections and busbar sizes can be found on page D.2.

Breaker type 'automatic'	Switch type 'non automatic'	Frame	In in A	Power loss at In per pole (W)	Temperature in the direct environment of the EntelliGuard				
					≤50°C	55°C	60°C	65°C	70°C
Maximum user Current le in A vertical connection mode: fixed pattern									
GT04R & K	G704R	T	400	4.6	400	400	400	400	400
GG04S N & H	GJ04S & GW04N	1	400	2.29	400	400	400	400	400
GG04 E and M	GJ04H	2	400	1.66	400	400	400	400	400
GT07R & K	G707R	T	630	11.8	630	630	630	630	630
GG07S N & H	GJ07S & GW07N	1	630	5.68	630	630	630	630	630
GG07 E and M	GJ07H	2	630	4.13	630	630	630	630	630
GT08K & R	G708R	T	800	19.2	800	800	800	800	800
GG08, S N & H	GJ08S & GW08N	1	800	9.15	800	800	800	800	800
GG08 E and M	GJ08H	2	800	6.66	800	800	800	800	800
GT10R & K	G710R	T	1000	30	1000	1000	1000	1000	1000
GG10S N & H	GJ10S & GW10N	1	1000	14.3	1000	1000	1000	1000	1000
GG10 E and M	GJ10H	2	1000	10.4	1000	1000	1000	1000	1000
GT13R & K	G713R	T	1250	46.9	1250	1250	1250	1250	1250
GG13, S N & H	GJ13S & GW13N	1	1250	22.3	1250	1250	1250	1250	1250
GG13 E and M	GJ13H	2	1250	16.3	1250	1250	1250	1250	1250
GT16R & K	G716R	T	1600	66.6	1600	1600	1600	1600	1600
GG16S N & H	GJ16S & GW16N	1	1600	36.6	1600	1600	1600	1600	1600
GG16 E and M	GJ16H	2	1600	26.6	1600	1600	1600	1600	1600
GG20, S N & H	GJ20S & GW20N	1	2000	57.2	2000	2000	2000	2000	2000
GG20 E and M	GJ20H	2	2000	41.6	2000	2000	2000	2000	2000
GG25N, H & M	GJ25N & GW25H	2	2500	65.0	2500	2500	2500	2500	2500
GG32N, H & M	GJ32N & GW32H	2	3200	106	3200	3200	3200	3150	3100
GG32G & L	GJ32G	3	3200	66.6	3200	3200	3200	3200	3200
GG40N, H & M	GJ40N & GW40H	2	4000	166	4000	3750	3600	3500	3400
GG40G & L	GJ40G	3	4000	104	4000	4000	4000	4000	4000
GG50M & L	GJ50L	3	5000	163	5000	5000	5000	4900	4800
GG64M & L	GJ64L	3	6400	266	6400	6300	6200	6100	6000
Maximum user current le in A vertical connection mode: draw-out types									
GT04R & K	G704R	T	400	8.8	400	400	400	400	400
GG04S N & H	GJ04S & GW04N	1	400	4.78	400	400	400	400	400
GG04 E and M	GJ04H	2	400	3.74	400	400	400	400	400
GT07R & K	G707R	T	630	21.8	630	630	630	630	630
GG07S N & H	GJ07S & GW07N	1	630	11.9	630	630	630	630	630
GG07 E and M	GJ07H	2	630	9.29	630	630	630	630	630
GT08R & K	G708R	T	800	35.2	800	800	800	800	800
GG08S N & H	GJ08S & GW08N	1	800	19.1	800	800	800	800	800
GG08 E and M	GJ08H	2	800	15.0	800	800	800	800	800
GT10R & K	G710R	T	1000	55	1000	1000	1000	1000	1000
GG10S N & H	GJ10S & GW10N	1	1000	29.9	1000	1000	1000	1000	1000
GG10 E and M	GJ10H	2	1000	23.4	1000	1000	1000	1000	1000
GT13R & K	G713R	T	1250	85.9	1250	1250	1250	1250	1250
GG13S N & H	GJ13S & GW13N	1	1250	46.7	1250	1250	1250	1250	1250
GG13 E and M	GJ13H	2	1250	36.6	1250	1250	1250	1250	1250
GT16R & K	G716R	T	1600	128	1600	1500	1450	1400	1350
GG16S N & H	GJ16S & GW16N	1	1600	76.5	1600	1600	1600	1600	1600
GG16 E and M	GJ16H	2	1600	59.9	1600	1600	1600	1600	1600
GG20S N & H	GJ20S & GW20N	1	2000	120	2000	2000	2000	2000	2000
GG20 E and M	GJ20H	2	2000	93.6	2000	2000	2000	2000	2000
GG25N, H & M	GJ25N & GW25H	2	2500	146	2500	2500	2500	2500	2500
GG32N, H & M	GJ32N & GW32H	2	3200	240	3200	3200	3200	3100	3000
GH32N, H & M	GK32N & GZ32H	2	3200	186	3200	3200	3200	3200	3200
GG32G & L	GJ32G	3	3200	106	3200	3200	3200	3200	3200
GG40N, H & M	GJ40N & GW40H	2	4000	374	3800	3700	3600	3500	3400
GH40N, H & M	GK40N & GZ40H	2	4000	291	4000	3950	3900	3835	3750
GG40G & L	GJ40G	3	4000	166	4000	4000	4000	4000	4000
GG50M & L	GJ50L	3	5000	260	5000	5000	5000	4900	4800
GG64M & L	GJ64L	3	6400	426	6400	6300	6200	6100	6000





## Heat dissipation, Watt loss and current ratings at temperatures >50°C

### EntelliGuard power circuit breakers

Other connection modes as rear connection with horizontal busbars and connection from the breaker front are possible. The tables here indicate the heat dissipation values and current ratings at temperatures within the direct vicinity of the breaker in free air.

The values apply for breakers used in rear connection mode with horizontal busbar connection and for devices with front connection.

The recommended connection cross sections and busbar sizes can be found on page D.2.

Breaker type 'automatic'	Switch type 'non automatic'	Frame	In in A	Power loss at In per pole (W)	Temperature in the direct environment of the EntelliGuard				
					≤50°C	55°C	60°C	65°C	70°C
Maximum user current Ie in A Horizontal or front <sup>(2)</sup> connection mode: fixed pattern									
GT04R & K	G704R	T	400	4.6	400	400	400	400	400
GG04S N & H	GJ04S & GW04N	1	400	2.29	400	400	400	400	400
GG04 E and M	GJ04H	2	400	1.66	400	400	400	400	400
GT07R & K	G707R	T	630	11.8	630	630	630	630	630
GG07S N & H	GJ07S & GW07N	1	630	5.68	630	630	630	630	630
GG07 E and M	GJ07H	2	630	4.13	630	630	630	630	630
GT08R & K	G708R	T	800	19.2	800	800	800	800	800
GG08S N & H	GJ08S & GW08N	1	800	9.15	800	800	800	800	800
GG08 E and M	GJ08H	2	800	6.66	800	800	800	800	800
GT10R & K	G710R	T	1000	30	1000	1000	1000	1000	1000
GG10S N & H	GJ10S & GW10N	1	1000	14.3	1000	1000	1000	1000	1000
GG10 E and M	GJ10H	2	1000	10.4	1000	1000	1000	1000	1000
GT13R & K	G713R	T	1250	46.9	1250	1250	1250	1250	1250
GG13, S N & H	GJ13S & GW13N	1	1250	22.3	1250	1250	1250	1250	1250
GG13 E and M	GJ13H	2	1250	16.3	1250	1250	1250	1250	1250
GT16R & K	G716R	T	1600	66.6	1600	1500	1450	1400	1350
GG16S N & H	GJ16S & GW16N	1	1600	36.6	1600	1600	1600	1600	1600
GG16 E and M	GJ16H	2	1600	26.6	1600	1600	1600	1600	1600
GG20, S N & H	GJ20S & GW20N	1	2000	57.2	2000	2000	2000	2000	2000
GG20 E and M	GJ20H	2	2000	41.6	2000	2000	2000	2000	2000
GG25N, H & M	GJ25N & GW25H	2	2500	65.0	2500	2500	2500	2500	2500
GG32N, H & M	GJ32N & GW32H	2	3200	106	3200	3200	3100	3050	3000
GG32G & L	GJ32G	3	3200	66.6	3200	3200	3200	3200	3200
GG40N, H & M -RH	GJ40N & GW40H-RH	2	(1)	(1)	(1)	(1)	(1)	(1)	(1)
GG40N, H & M-FC	GJ40N & GW40H-FC	2	4000	166	4000	3700	3400	3200	3000
GG40G & L	GJ40G	3	4000	104	4000	4000	4000	4000	4000
GG50M & L	GJ50L	3	5000	163	5000	5000	5000	4875	4750
GG64M & L	GJ64L	3	(1)	(1)	(1)	(1)	(1)	(1)	(1)
Maximum user current Ie in A Horizontal or front <sup>(2)</sup> connection mode: draw-out types									
GT04R & K	G704R	T	400	8.8	400	400	400	400	400
GG04S N & H	GJ04S & GW04N	1	400	4.8	400	400	400	400	400
GG04 E and M	GJ04H	2	400	3.74	400	400	400	400	400
GT07K	G707R	T	630	21.8	630	630	630	630	630
GG07S N & H	GJ07S & GW07N	1	630	11.9	630	630	630	630	630
GG07 E and M	GJ07H	2	630	9.3	630	630	630	630	630
GT08R & K	G708R	T	800	35.2	800	800	800	800	800
GG08S N & H	GJ08S & GW08N	1	800	19.1	800	800	800	800	800
GG08 E and M	GJ08H	2	800	15.0	800	800	800	800	800
GT10R & K	G710R	T	1000	55	1000	1000	1000	1000	1000
GG10S N & H	GJ10S & GW10N	1	1000	29.9	1000	1000	1000	1000	1000
GG10 E and M	GJ10H	2	1000	23.4	1000	1000	1000	1000	1000
GT13R & K	G713R	T	1250	85.9	1250	1250	1250	1250	1250
GG13S N & H	GJ13S & GW13N	1	1250	47	1250	1250	1250	1250	1250
GG13 E and M	GJ13H	2	1250	36.6	1250	1250	1250	1250	1250
GT16R & K	G716R	T	1600	128	1600	1500	1400	1350	1250
GG16S N & H	GJ16S & GW16N	1	1600	77	1600	1600	1600	1600	1600
GG16 E and M	GJ16H	2	1600	60	1600	1600	1600	1600	1600
GG20S N & H	GJ20S & GW20N	1	2000	120	2000	2000	2000	2000	2000
GG20 E and M	GJ20H	2	2000	94	2000	2000	2000	2000	2000
GG25N, H & M	GJ25N & GW25H	2	2500	146	2500	2500	2500	2500	2500
GG32N, H & M	GJ32N & GW32H	2	3200	240	3200	3200	3200	3200	2900
GH32N, H & M	GK32N & GZ32H	2	3200	186	3200	3200	3200	3200	3000
GG32G & L	GJ32G	3	3200	106	3200	3200	3200	3200	3200
GG40N, H & M -RH	GJ40N & GW40H-RH	2	(1)	(1)	(1)	(1)	(1)	(1)	(1)
GG40N, H & M-FC	GJ40N & GW40H-FC	2	4000	374	4000	3700	3400	3200	3000
GH40N, H & M	GK40N & GZ40H	2	(1)	(1)	(1)	(1)	(1)	(1)	(1)
GG40G & L	GJ40G	3	4000	166	4000	4000	4000	4000	4000
GG50M & L	GJ50L	3	5000	260	5000	5000	5000	4850	4700
GG64M & L	GJ64L	3	(1)	(1)	(1)	(1)	(1)	(1)	(1)

(1) Rear horizontal connections cannot be used at this current rating

(2) Front connections are available for the standard frame 1 and frame 2 types (not available for GH,GK and GZ types)



## Selectivity/Discrimination

### Selectivity - Discrimination

In a low voltage distribution network it is necessary that on a fault the protection device nearest to the fault reacts whilst all others remain closed.

This capability is called discrimination (UK) or Selectivity (USA and Europe).

If this requirement is not met a fault in one arm of the distribution system could cause a number of upstream protection devices to react and open. A relatively minor fault in one arm of a complete distribution will then cause a power interruption across a major part of the installation.

### EntelliGuard power circuit breakers

A combination of the high precision and multiple bands of the EntelliGuard electronic trip unit allow full selectivity to be achieved between closely rated devices over multiple levels. The table included here indicates the recommended settings of the downstream protection devices and the upstream EntelliGuard breaker.

A second table on page D.7 indicates the discrimination / selectivity that can be achieved with these settings.

The tables can replace the complex and time consuming method of comparing multiple time current curves across many levels.

Downstream device	Trip unit	Setting denomination	Settings determining selectivity	Recommended EntelliGuard settings				
				I <sub>r</sub> or I <sub>e</sub> setting Ratio	LTDB setting band	I <sub>st</sub> setting Ratio	STDB setting band	I setting
<i>Record Plus</i>								
FD & FE frame	LTMD	I <sub>r</sub>	Ratio & Band	1.6 x	C22			
		I <sub>m</sub>	Ratio & Band			1.6 x	Band 2	
FD & FE frame	GTM	I <sub>r</sub>	Ratio & Band	1.6 x	C22			Minimum setting 5kA - FD160, 7kA - FE160, 9kA - FE250 or I = 'OFF'
		I <sub>m</sub>	Ratio & Band			1.6 x	Band 2	
FE frame	PremEon	LTD line	Band		C8			
		LTD Motor	Band		C14			
		I <sub>st</sub>	Ratio & Band			1.35 x	Band 2	
FG frame	PremEon	LTD line	Band		C8			
		LTD Motor	Band		C14			
		I <sub>st</sub>	Ratio & Band			1.35 x	Band 3	
		I <sub>r</sub>	Ratio	1.3 x				Minimum setting 14kA - FG400, 18kA - FG630 or use ZSI or I = 'OFF'
		LTD cl. 1.25	Band		C3			
		LTD cl. 2.5	Band		C5			
		LTD cl. 5	Band		C8			
		LTD cl. 10	Band		C12			
		LTD cl. 20	Band		C16			
		LTD cl. 30	Band		C18			
		I <sub>st</sub>	Ratio			1.35 x		
		STD = 420ms	Band				Band 13	
		STD = 310ms	Band				Band 11	
		STD = 210ms	Band				Band 9	
		STD = 120ms	Band				Band 6	
		STD = 40ms	Band				Band 3	
FK frame	SMR1e	I <sub>r</sub>	Ratio & Band	1.4 x	C8			Minimum setting
		I <sub>st</sub>	Ratio			1.35 x		
		STD	Band				Band 7	
		I <sub>r</sub>	Ratio	1.4 x				Minimum setting 18kA - FK800 20kA - FK1000 20kA - FK1250 28kA - FK1600 or use ZSI or I = 'OFF'
		LTD cl. 5	Band		C8			
		LTD cl. 10	Band		C12			
		LTD cl. 20	Band		C19			
		LTD cl. 30	Band		C22			
		I <sub>st</sub>	Ratio					
		STD = 300ms	Band				Band 12	
		STD = 200ms	Band				Band 10	
		STD = 100ms	Band				Band 7	
EntelliGuard	GT-E	I <sub>r</sub>	Ratio	1.25 x				Use ZSI or I = 'OFF'
		LTD class	Band		2 higher			
		I <sub>st</sub>	Ratio			1.25 x		
		STD band min. until 11	Band				2 higher	
		STD band ≤12	Band				1 higher	
		I <sub>r</sub>	Ratio	1.25 x				
		LTD class	Band		2 higher			
		I <sub>st</sub>	Ratio			1.25 x		
		STD band min. until 11	Band				2 higher	
		STD band ≤12	Band				1 higher	
Industrial fuses GL/Gg type	---	Current rating	Ratio & Band	2 x	F20	ST = 8 x I <sub>r</sub> , STDB band 5 and I = 12 x I <sub>e</sub>		



Selectivity with downstream devices, tables

Downstream device	Trip unit	Upstream EntelliGuard device and selectivity limit Is <sup>(1)</sup>										
		GT04R to GT16R	GT04K to GT16K	GG04S to GG20S	GG04N to GG20N	GG25N to GG40N	GG04E to GG20E	GG(H)25H to GG(H)40H	GG(H)25M to GG(H)40M	GG32G to GG40G	GG40M to GG64M	GG40L to GG64L
<b>ElfaPlus MCBs</b> EP30, 45, 60, 100 & 250, CP30, 45 & 60, DME60, DPE100, DPA160, DPA100 & DPT100	All	T	T	T	T	T	T	T	T	T	T	T
<b>ElfaPlus MCBs</b> HTI & S90 C curve	All	T	T	T	T	T	T	T	T	T	T	T
<b>Surion manual motor starters</b> GPS1BS ≤ 10A GPS1MH ≤ 12.5A GPS2BS 10A, GPS2MH 10A	All	T	T	T	T	T	T	T	T	T	T	T
<b>Surion manual motor starters</b> GPS1BS, GPS1MS 12.5kA, GPS1MH > 12.5A GPS2MH > 10A	All	T	T	T	T	T	T	T	T	T	T	T
<b>Surion manual motor starters</b> GPS1BS, GPS1MS ≥ 16A, GPS2BS > 10A	All	T	T	T	T	T	T	T	T	T	T	T
<b>Record Plus</b> FD & FE frame C, E, V, S tiers	All	T	T	T	T	T	T	T	T	T	T	T
FD & FE frame N tier	All	T	T	T	T	T	T	T	T	T	T	T
FD & FE frame H tier	All	T	T	T	T	T	T	T	T	T	T	T
FD & FE frame L tier	All	T	T	T	T	T	T	T	T	T	T	T
FG frame N tier	All	T	T	T	T	T	T	T	T	T	T	T
FG frame H tier	All	T	T	T	T	T	T	T	T	T	T	T
FG frame L tier	All	T	T	T	T	T	T	T	T	T	T	T
FK frame N tier	All	T	T	T	T	T	T	T	T	T	T	T
FK frame H tier	All	T	T	T	T	T	T	T	T	T	T	T
FK frame L tier	All	T	T	T	T	T	T	T	T	T	T	T
<b>EntelliGuard</b> GT04R to GT16R	All	42kA <sup>(2)</sup>	T									
GT04K to GT16K	All	42kA <sup>(2)</sup>	50kA <sup>(2)</sup>									
GG04S to GG20S	All	--	--	50kA <sup>(2)</sup>	T	T	T	T	T	T	T	T
GG04N to GG20N	All	--	--	50kA <sup>(2)</sup>	65kA <sup>(2)</sup>	65kA <sup>(2)</sup>	T	T	T	T	T	T
GG04E to GG20E	All	--	--	50kA <sup>(2)</sup>	65kA <sup>(2)</sup>	65kA <sup>(2)</sup>	85kA <sup>(2)</sup>	85kA <sup>(2)</sup>	85kA <sup>(2)</sup>	T	T	T
GG(H)25H to GG(H)40H	All	--	--	--	--	65kA <sup>(2)</sup>	--	85kA <sup>(2)</sup>	85kA <sup>(2)</sup>	T	T	T
GG(H)25M to GG(H)40M	All	--	--	--	--	65kA <sup>(2)</sup>	--	85kA <sup>(2)</sup>	85kA <sup>(2)</sup>	T	T	T
GG(H)40M to GG(H)64M	All	--	--	--	--	--	--	--	--	--	100kA <sup>(2)</sup>	100kA <sup>(2)</sup>
GG(H)40L to GG(H)64L	All	--	--	--	--	--	--	--	--	--	100kA <sup>(2)</sup>	100kA <sup>(2)</sup>
<b>Industrial fuses</b> GL/Gg type	---	T	T	T	T	T	T	T	T	T	T	T

(1) T = Full selectivity until the Icu of the downstream or upstream device (the lowest of the two)  
 (2) Indicated values apply with I (Instantaneous) ON, if Off reduce by 10%



## Protection of standard circuits<sup>(1)</sup>

### Protection of standard circuits

Protection devices as the EntelliGuard power circuit breaker are used in a wide variety of environments to protect conductors, equipment and devices in low voltage distribution circuits. To use this product to its full potential it is necessary to verify that it functions correctly in the environment in which it is used, and that it meets the electrotechnical requirements of the circuit it protects.

### Environment

EntelliGuard will function well in almost any industrial environment and fully complies with the environmental requirements of the relevant EN 60 947-2 standard. For conditions other than the above mentioned, please refer to page D.10 of this section.

### Maximum short-circuit current

Each protective device must be capable of interrupting the maximum short-circuit current at the point where it is installed (see HD 384 standard). The interruption ratings (breaking capacities) of the EntelliGuard circuit breaker can be found on pages 2, 3 & 4 of this catalogue.

### Design current of a circuit

The equipment and devices in an electrical circuit determine its current load or design current  $I_b$ . A circuit breaker's overload or  $I_r$  setting is normally adjusted to a value equal to the design current.

### Weakest short-circuit current in a circuit

On a short-circuit event the total circuit impedance determines both the MAXIMUM and WEAKEST short-circuit current that can flow in the circuit. For the weakest short circuit current it is necessary to establish if the protection device trips before the electrical conductors reach their maximum temperature, this for operating times of 0.1 to 5 seconds.

### Fault currents

In the 2005 edition of the IEC 60364-4-41 the general terminology 'protection against electrical shock' has been adapted whilst two new terms have been introduced:

- 1) Protection under normal conditions now designated: **Basic protection**
- 2) Protection under fault conditions now designated: **Fault protection**

Fault protection being provided by protective equipotential bonding and automatic disconnection of the supply. Under fault conditions, depending on the network an interruption time of 5 seconds (TN) or 1 second is required (TT) for circuits with a rating  $>32A$ . Depending on the configuration of the earthing system the 1 and 5 second disconnection time is also required for interruption of a second fault in IT systems.

### EntelliGuard power circuit breakers

To protect standard circuits, the breakers are equipped with a number of protection devices.

### Overload protection device

The first is a highly accurate menu driven overload protection device that has an adjustment range of 0.2 to 1 x the breaker rating. Six main current ratings ( $I_e$ ) are available. Each have a sub setting ( $I_r$ ) of 0.5 to 1 times the chosen  $I_e$  rating. This device is normally set to a value that is equal or closely matches the design current ( $I_b$ ).

### Timed short-circuit protection device

Set as a multiple of the overload adjustment. this device offers a broad adjustment range of 2 to 12. The setting of this device depends on several parameters as the inrush characteristics of the protected devices. a protection against the **weakest short-circuit current** and in some cases against fault currents to earth. 17 narrow and accurate time bands allow the EntelliGuard power circuit breaker to interrupt a fault within the timing required by the standards. to offer selectivity across multiple levels and allow the user to take inrush currents into account.

### Ground fault protection

It is possible to combine two devices in one. both designed to detect **Fault Currents** to earth. They can be set as a multiple of the value of the current sensors mounted in the breaker and have a broad adjustment range of 0.2 to 1 (0.1 -1 with an auxiliary power supply). The first is a residual device that takes the sum of the current in the three phases and neutral. If this is no longer equal to zero it sends an alarm or trips the breaker. The second allows the user to measure the return current running between the earth leg and neutral. On detecting a fault to earth the device sends an alarm, or trips the breaker. 14 narrow and accurate time bands allow the EntelliGuard G power circuit breaker to interrupt a fault within the timing required by the standards and offer selectivity across multiple levels.

### Instantaneous short-circuit protection

Set as a multiple of the primary overload adjustment  $I_e$  this device offers a broad adjustment range of 2 to 15 (2-30 on request). This device is normally used to limit the time that higher short-circuit currents can run in the protected circuit. Whilst the timed short-circuit protection device waits for a set time, the instantaneous device immediately trips the breaker once the set value is reached. The device used in the EntelliGuard power circuit breaker maintains selectivity by only reacting to the 2nd half wave of a short-circuit current and uniquely allows the use of the 'Zone Selective Interlock' feature (see section B).

(1) For more details see section E of the 2010 edition of the Record Plus catalogue.



## Applications

### Protection of generator sets, motors, capacitor banks and transformers

#### Use of EntelliGuard breakers in Automatic Power transfer Systems (ATS)

#### Introduction

The Electronic trip unit used in the EntelliGuard power circuit breaker offers many additional protection devices, a full description of which can be found in section B. Here a number of the possible applications of these devices is described briefly.

#### Protection of generator sets

The overload and short-circuit devices used to protect a generator need to react quicker and at lower current levels than those used to protect other devices.

After establishing the capabilities of the generator set under overload and short-circuit conditions, the protection devices need to be adjusted accordingly.

On a power circuit breaker use of the 'faster' overload protection bands (LTDB set between minimum and the C6 band) and a low setting of the timed short-circuit protection ( $2.5 \times I_r$ ) is recommended. The optional 3 phase undervoltage protection available in the GT-H trip unit can also be considered.

#### Protection of motors

On starting electrical motors draw more current than when running under normal conditions. These starting currents differ strongly per type and should not cause tripping of the device protecting the circuit.

The IEC 60947-4 has defined four different 'operational' or 'Trip' classes:

Trip class	Required tripping times at		
	$1.2 \times I_n$	$1.5 \times I_n$	$7.2 \times I_n$
10A	$t < 2$ hours	$t < 2$ min	$2 \leq t < 10$ sec.
10	$t < 2$ hours	$t < 4$ min.	$4 \leq t \leq 10$ sec.
20	$t < 2$ hours	$t < 8$ min.	$6 \leq t \leq 20$ sec.
30	$t < 2$ hours	$t < 12$ min.	$9 \leq t \leq 30$ sec.

This table is in some cases extended to include a 'trip class 40' (assumed to be a 15-40 second band at  $7.2 \times I_n$ ).

On a power circuit breaker, use of the 'slower' protection bands that closely match the indicated classes is recommended (LTDB set between the C-8 to the C-22 band).

Switching on a motor also produces a high but very short inrush peak current which could activate the short-circuit protection of a breaker and cause unexpected tripping. Here the timed short-circuit device of a power circuit breaker must be set to at least  $12 \times I_r$  with a time delay of 50 milliseconds (STDB band 3). If an instantaneous protection device is present and switched on, a setting of at least  $12 \times I_e$  is recommended.

After an overload event the motor and wiring are still warm, immediate re-energization of the electrical circuit could result in damage of the electrical circuit and the motor.

The overload protection device must incorporate a thermal memory device that prevents re-energization before a certain cooling time has elapsed.

#### Remark

For an overview of the used abbreviations (as LTDB and STDB) see page B.22.

Furthermore, the prevention of anomalies as the motor losing a phase or a motor with blocked rotor need to be prevented and require additional protection devices.

Next to the 'standard' protection devices the EntelliGuard electronic trip unit has a thermal memory function, an optional 3 phase undervoltage relay and current unbalance device thus providing comprehensive motor protection.

#### Protection of capacitor banks

Power circuit breakers are designed to offer high making and breaking capacities under adverse conditions: the switching of capacitor banks has little to no effect on the breaker, its characteristics as a protective device or on its lifespan.

However the current flowing in the circuit can trip a circuit breaker and a capacitor load does display certain anomalies. Here the current flowing in the circuit cannot be assumed to be the calculated capacitor current only. The effective current value is higher due to harmonic content (normally assumed as 30%) and an allowance must be made for tolerances in the capacitance of the units (10%). The protection devices of the power circuit breaker must be set accordingly.

#### Protection of LV/LV transformers

Transformers generally produce a very high inrush current. The crest values of the first half cycle may reach values of 15 to 25 time the normal rated current.

Manufactures data and tests have indicated that a protection device feeding a transformer must be capable of carrying the following current values without tripping.

Transformer value	imum crest inrush values		
	1st period	2nd period	After 3 periods
$< 50$ kVA	$25 \times I_n$	$12 \times I_n$	$5 \times I_n$
$\geq 50$ kVA	$15 \times I_n$	$8 \times I_n$	$3.5 \times I_n$

It is recommended that the timed short-circuit device of a power circuit breaker is set to at least  $8 \times I_r$  with a time delay of 30 milliseconds (STDB band 1). If an instantaneous protection device is present, the use of the extended adjustment range with setting of  $20 \times I_e$  is advisable ( $=15 \times I_n$  plus tolerances).

#### Automatic transfer systems

EntelliGuard power circuit breakers are available with mechanical interlocks for 2 to 3 breakers and have a unique electrical network interlocking system allowing the user to completely lock out one of more breakers.

The logical transfer of power from one source to another is thus strongly simplified whilst the high speed electrical closing and opening of the device allows their use in synchronization applications.

Here, numerous other EntelliGuard protection features can be used, one of which being the electronic trip units 3 phase undervoltage release. This to establish if voltage on a certain power source is present and if a generator set has reached its nominal voltage.



## Environmental considerations

### Ambient temperature

EntelliGuard power circuit breakers are designed to operate normally at temperatures of -5 degrees to +70°C. They can be used at temperatures down to -20°C with a reduced electrical and mechanical life span.

To prevent materials from reaching temperatures that have an adverse effect on their electrical and/or mechanical properties, derating factors must be applied when the device is used in ambient temperatures higher than 50°C.

### Storage temperature

Power circuit breakers can be stored at non operational temperatures of -40 degrees up to +70°C.

### Influence of altitude

Up to an altitude of 2000m above sea level no derating of breaker current or rated voltage is applicable. For altitudes above 2000m the following derating factors apply:

Altitude	Altitude correction factors		
	≤ 2000M	2500M	4000M
Voltage (Ue)	1	0.95	0.8
Current (In)	1	0.99	0.96

### Other atmospheric conditions

The EntelliGuard breaker line has been designed to operate at the temperatures and relative humidities defined in the EN 60947 clause 6.1.3.1.

They also meet the requirements of the following standards:

IEC 68-2-1	Cold
IEC 68-2-2	Dry heat
IEC 68-2-3	Damp heat
IEC 68-2-11	Salt
IEC 68-2-14	Change of temperature
IEC 68-2-30	Damp heat cyclic
IEC 721	Climatic

### Shock and vibration

Power circuit breakers meet the shock and vibration requirements of the Lloyd's Register of Shipping, the Germanischer Lloyd and the American Board of shipping.

They also meet the requirements of the following standards:

IEC 68-2-6	Vibration
IEC 68-2-27	Shock test
IEC 68-2-29	Bump
IEC 68-2-31	Drop test

### Other

All EntelliGuard devices meet the existing European ROHS directive and carry the CE mark.

### Electromagnetic compatibility

The EntelliGuard power circuit breaker and its electronic trip unit meet the most stringent requirements off the EN60947-2 and IEC 1004 standard. The following tests have been successfully completed.

### Harmonics, current dips, interruptions and power frequency variations

All EN 60947 Annex F, Sub-clause F4.1 through 3 requirements covering non sinusoidal currents resulting from harmonics are met. Testing covering the following elements:

- Wave forms consisting of a fundamental + 3rd harmonic component at 50 and 60Hz
- Wave forms consisting of a fundamental + 5th harmonic component at 50 and 60Hz
- Composite wave forms with a fundamental component + a 3rd, 5th and 7th harmonic at 50 and 60Hz
- Current dips and current interruptions
- Frequency variations from 45 to 65Hz in 1 Hz steps

### Electrostatic discharge

En 60947 Annex F, Sub-clause F and the IEC 1004-2

- Passed level 4, air discharge 15kV

### Radiated, radio frequency, electromagnetic field immunity test

EN 60947-2 Annex F, Sub-clause F7 and the IEC 1000-4-3 (basic standard)

- Passed higher than level 4 .... Field strength 30V/m

### Electrical fast transient/burst

EN 60947-2 Annex F, Sub-clause F5 and the IEC 1000-4-4 (basic standard)

- Passed level 4 burst peak voltage 4kV

### Surge immunity test

EN 60947-2 Annex F, Sub-clause F5 and the IEC 1000-4-5 (basic standard)

- Passed level 4 Voltage 1.2µs/50µs 6kV; current 8µs/20µs 3kA

### Dry heat test

EN 60947-2 Annex F, Sub-clause F8

- Passed all test requirements

### Thermal shock test

EN 60947-2 Annex F, Sub-clause F9

- No nuisance tripping within the 28-day temperature cycles

- Wiring diagrams**
- E.2 Breaker connection schemes Terminal A (all frames)
  - E.4 Breaker connection schemes Terminal A (all frames) and Terminal B (frames 1, 2 and 3 only)
  - E.5 Breaker connection schemes Terminal B (frames 1, 2 and 3 only)
  - E.6 Cassette and trip unit connection schemes (all frames)
  - E.7 Trip unit connection schemes (all frames)

The breaker

Order codes

Electronic trip units

Breaker accessories

Application guide

**Wiring diagrams**

Dimensions

Numerical index

Intro

A

B

C

D

**E**

F

X



## Breaker connection schemes

### Standard use of Terminal block A on frame T

One Terminal block A is supplied with each breaker

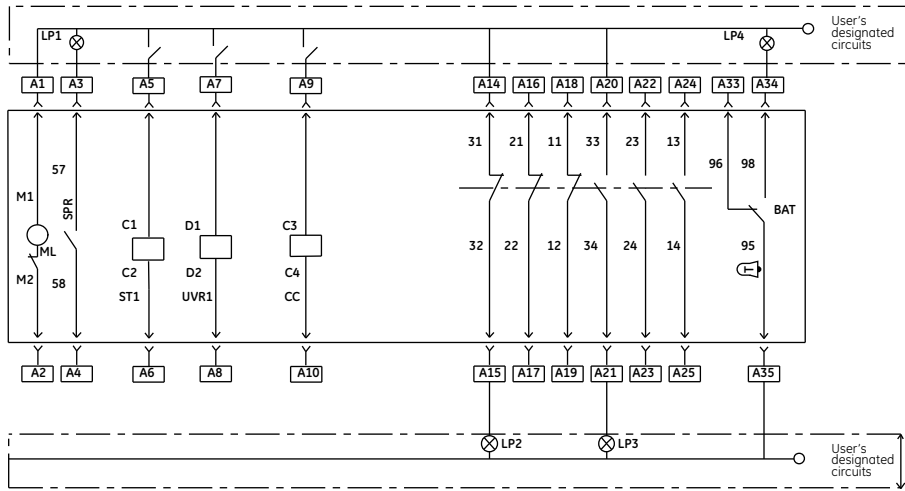

### Standard use of Terminal block A on frames 1, 2 & 3

One Terminal block A is supplied with each breaker

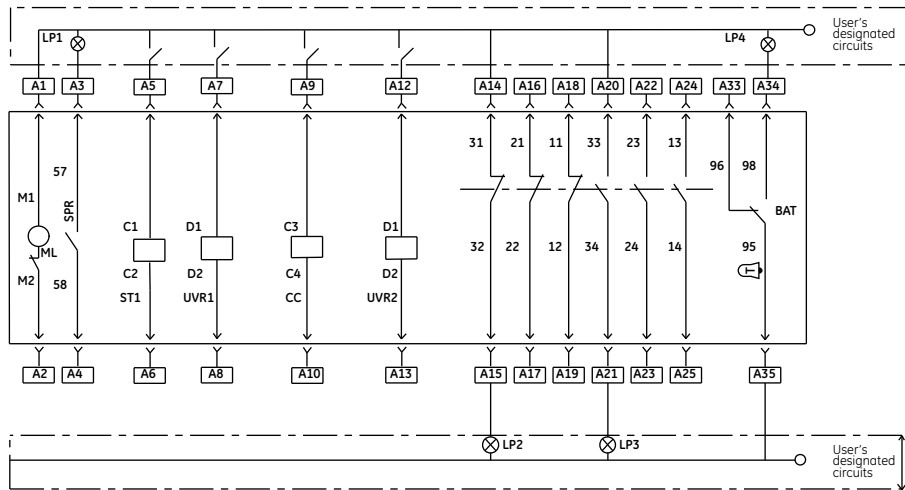



Breaker connection schemes

Extended use of Terminal block A on frame T

Used with 4NO & 4NC auxiliary contacts

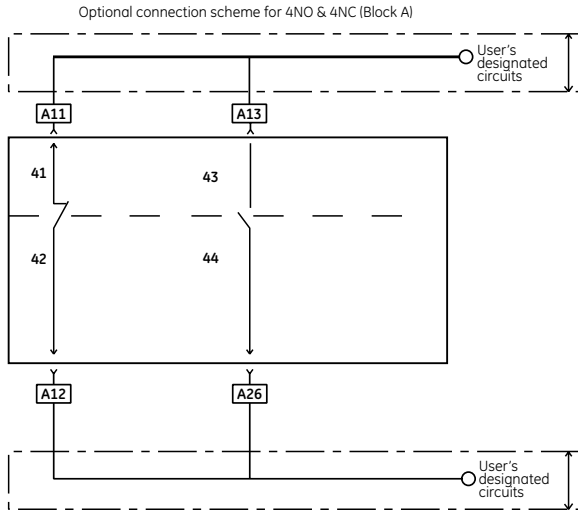

User designated circuits; indicators

- LP1: Spring charge status
- LP2: Breaker open
- LP3: Breaker closed
- LP4: Fault
- LP5: Breaker ready to close

Terminology

- CC: Close coil
- ST: Shunt release
- UVR: Undervoltage release
- SPR: Spring charge status
- RTC: Ready to close status
- M: Motor operator
- BAT: Bell alarm trip
- CCC: Comand close coil
- NI: Network interlock

Optional use of Terminal block A on ALL frames

Used with a command closing coil (CCC)

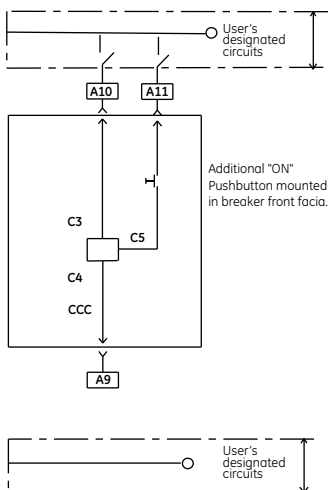

Used with a 2nd shunt release (Replacing 2nd UVR release)

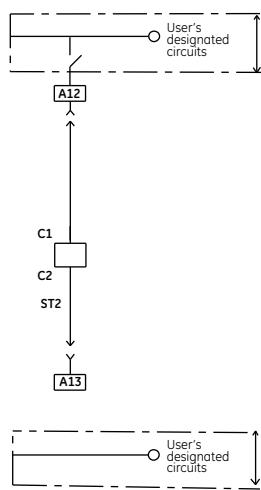

Used with a RTC contact (Replacing SPR contact)

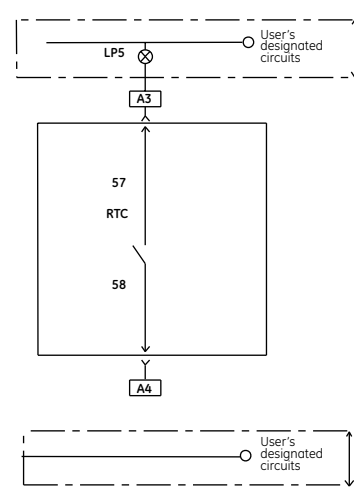

(1) Only possible on frame T with a set of 3NO plus 3NC auxiliary contacts  
 (2) Only possible on frames 1, 2 & 3 (Not on frame T)



## Breaker connection schemes

### Optional use of Terminal block A on frames 1, 2 & 3

Used with a remote reset coil (replacing shunt release coil)

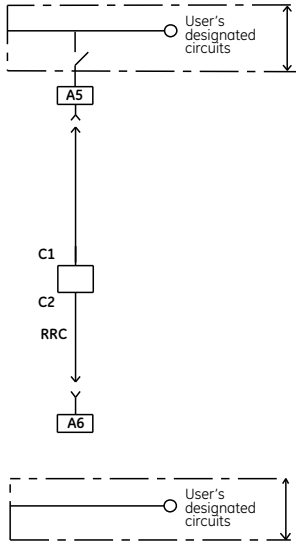

Used with a network interlock (NI) (replacing 1 UVR and 1 ST)

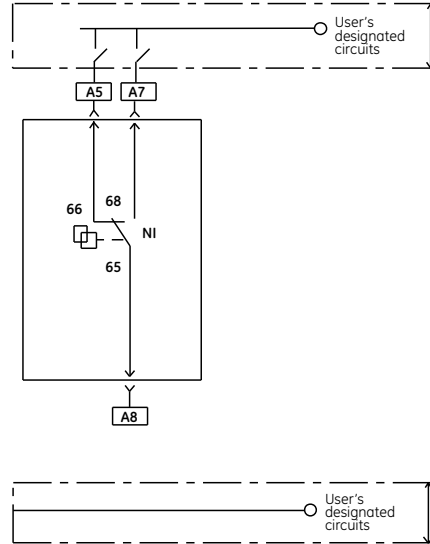

### Standard use of Terminal block B on frames 1, 2 & 3

Terminal block B is supplied with factory mounted breakers, when needed.

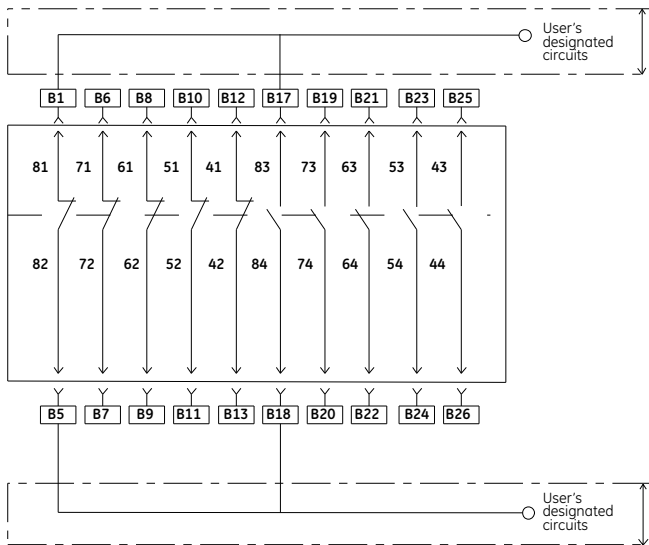

### Optional use of Terminal block B on frames 1, 2 & 3

Used with a network interlock (NI) (replacing 2 NO aux. contacts)

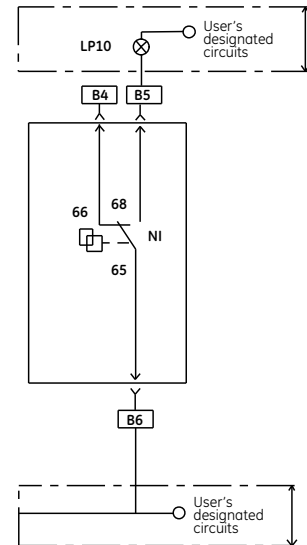

**Remark:**

When the auxiliary contact set contains TWO signal rated types these are connected to terminals: B10-B11, B12-B13, B23- B24 & B25-B26

When the auxiliary contact set contains FOUR signal rated types these are connected to terminals: B4-B5, B6-B7, B8-B9, B10-B11, B17-B18, B19-B20, B21-B22 & B23-B24



Breaker connection schemes

Optional use of Terminal block B on frames 1, 2 & 3

Used with coil indication contacts (replacing 2 NC and 1 NO aux. contact)

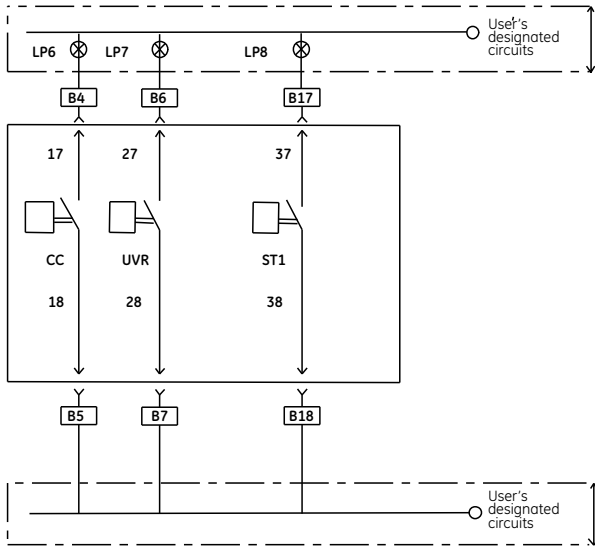

Used with coil indication contact (replacing 1NO aux. contact)

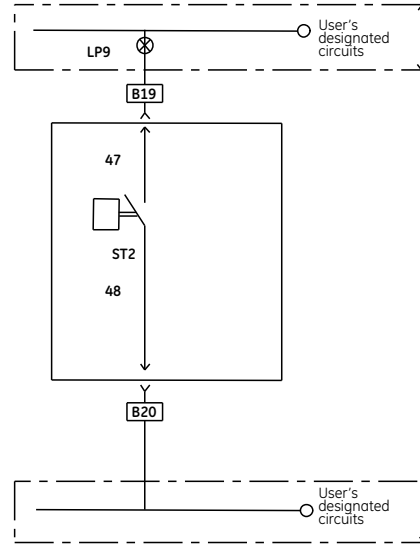

Optional use of Terminal block B on frames 1, 2 & 3

Used with coil indication contact (replacing 1 NO aux. contact)

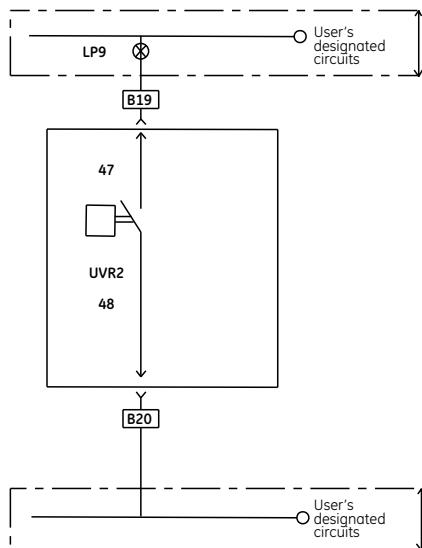

User designated circuits; indicators

- LP6: CC powered
- LP7: UVR not powered
- LP8: ST powered
- LP9: ST2 powered/UVR2 not powered
- LP10: Network interlock lockout

Terminology

- CC: Close coil
- ST: Shunt release
- UVR: Undervoltage release
- SPR: Spring change status
- NI: Network interlock



## Cassette & trip unit connection schemes

### Optional cassette indication switches valid for ALL frames

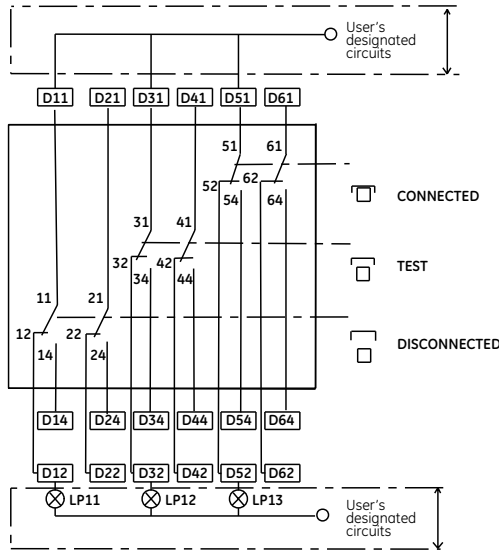

**User designated circuits; indicators**  
 LP11: Breaker in disconnected position  
 LP12: Breaker in test position  
 LP13: Breaker in connected position

### Trip unit type GT-E, valid for ALL frames

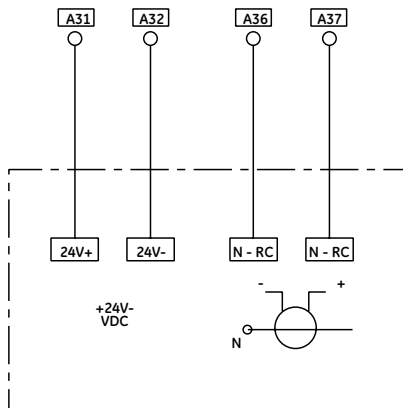

**Trip unit connection schemes**

**Trip unit type GT-S, valid for ALL frames**

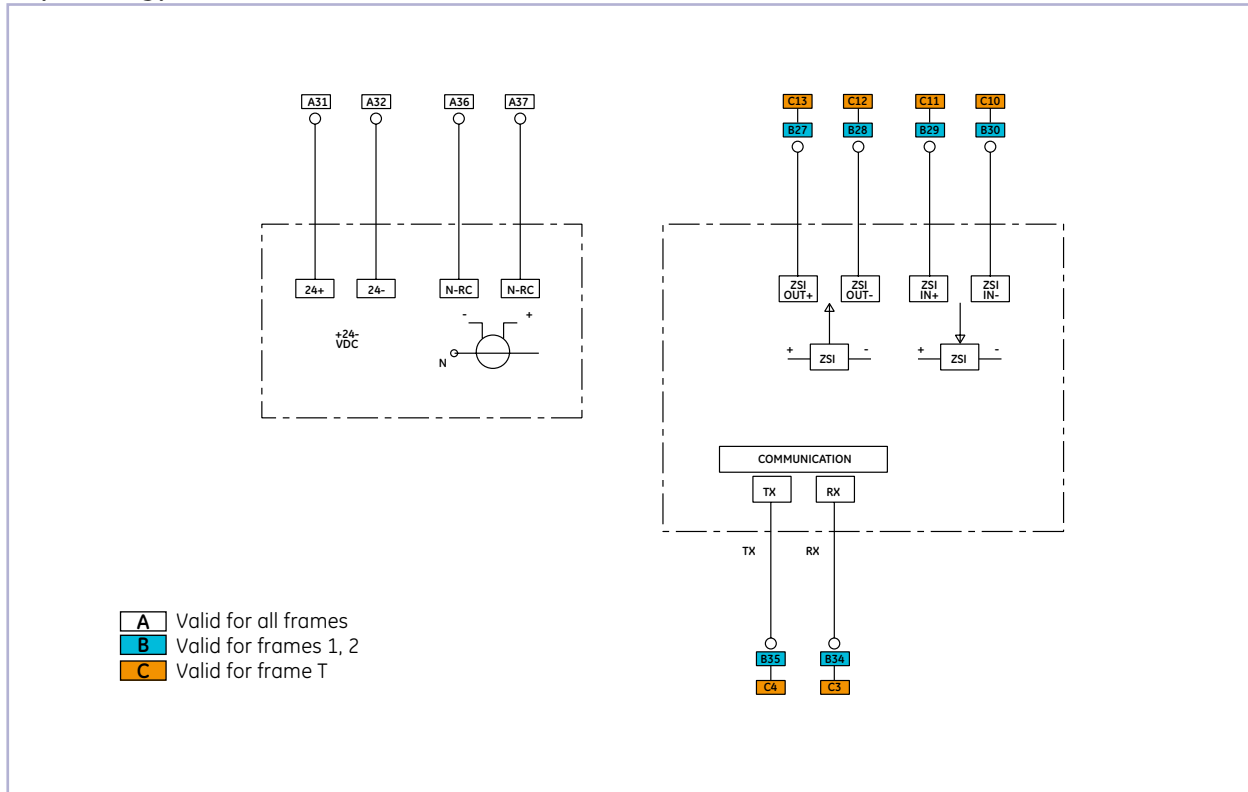

**Trip unit type GT-N, valid for ALL frames**

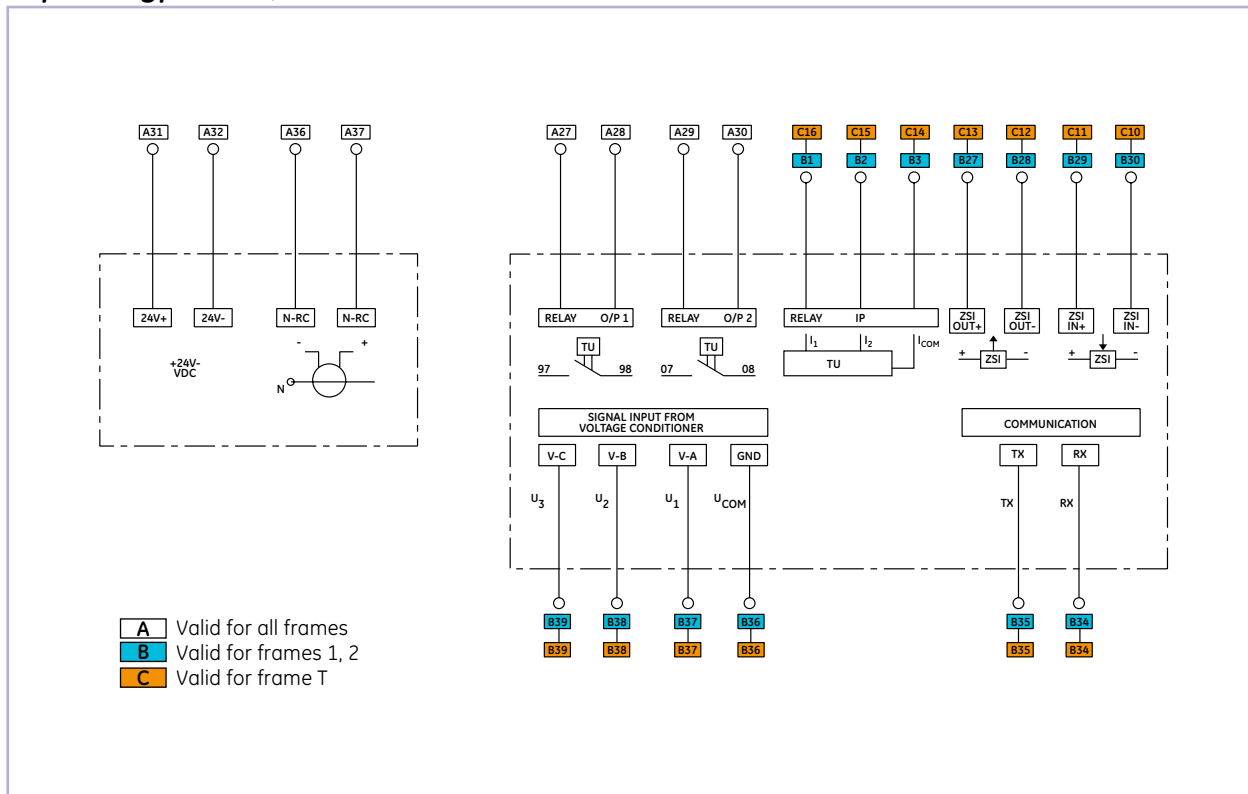

## Trip unit connection schemes

### Trip unit type GT-H, valid for ALL frames

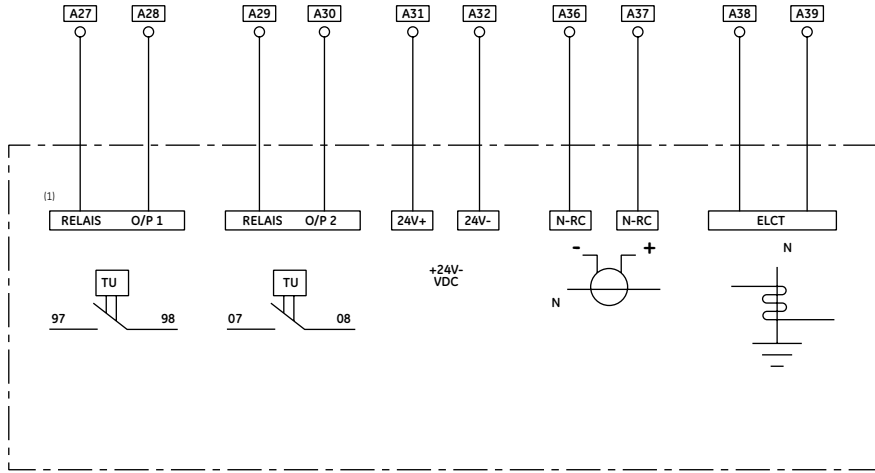

- A Valid for all frames
- B Valid for frames 1, 2
- C Valid for frame T

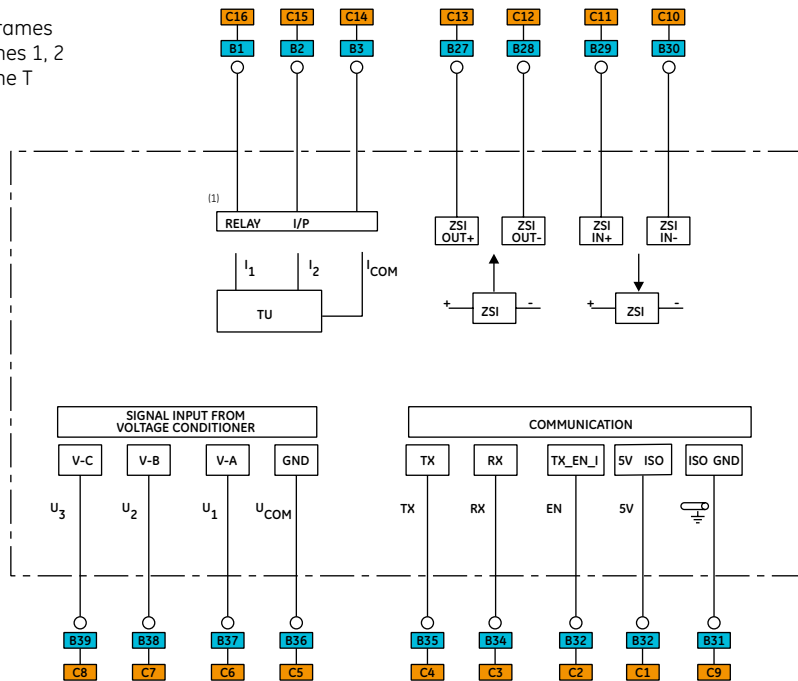

#### Terminology

- |            |                                     |                |                                       |
|------------|-------------------------------------|----------------|---------------------------------------|
| 24V+/24V-: | Auxiliary power supply to trip unit | ELCT:          | Earth leg CT                          |
| N-RC:      | Neutral Rogowski coil               | RELAY O/P:     | Relay OUT PUT                         |
| RXD:       | Modbus/Profibus communication       | RELAY I/P:     | Relay IN PUT                          |
| TXD:       | Modbus/Profibus communication       | V-A/V - B/V-C: | Signal input from voltage conditioner |
| TX_EN_I:   | Profibus communication              | GND:           | Ground for voltage                    |
| 5V ISO:    | Profibus communication              | ZSI OUT:       | Zone selective interlock OUT          |
| ISO GND:   | Profibus communication              | ZSI IN:        | Zone selective interlock IN           |

(1) Relay output one and electronic input one are assigned to RELT function.  
Note : When NRC is NOT connected to GTU , Please keep A36-A37 shorted



## Dimensions

- F.2 Frame T - Fixed type
- F.3 Frame T - Draw-out type
- F.5 Frame T - Optional connection modes
- F.6 Frame 1 - Fixed type
- F.7 Frame 1 - Draw-out type
- F.9 Frame 2 - Fixed type
- F.10 Frame 2 - Draw-out type
- F.11 Frame 2 - "Limited derating" draw-out type
- F.12 Frame 1 & 2 - Optional connection modes
- F.13 Frame 3 - Fixed type
- F.15 Frame 3 - Draw-out type
- F.18 IP54 Flange, time delay module UVR, 24V power supply
- F.19 Rogowski's, current transformers,  
door interlock system & wall mounting brackets
- F.20 Interlocking with cable systems, 2-way
- F.21 Interlocking with cable systems, 3-way

The breaker

Order codes

Electronic trip units

Breaker accessories

Application guide

Wiring diagrams

**Dimensions**

Numerical index

Intro

A

B

C

D

E

**F**

X



## Frame T – Fixed pattern

Front view 4 pole

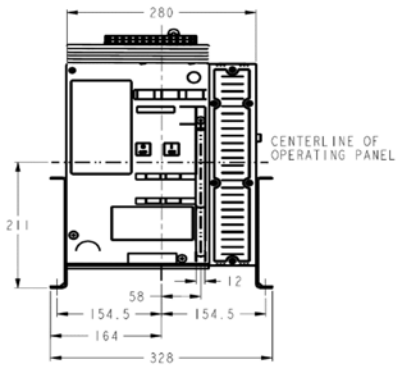

Front view 3 pole

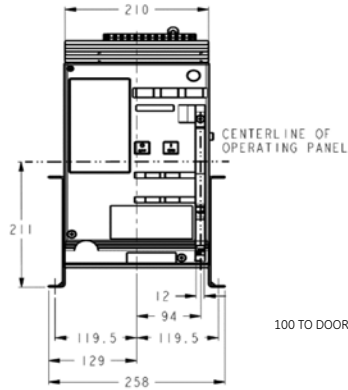

Side view

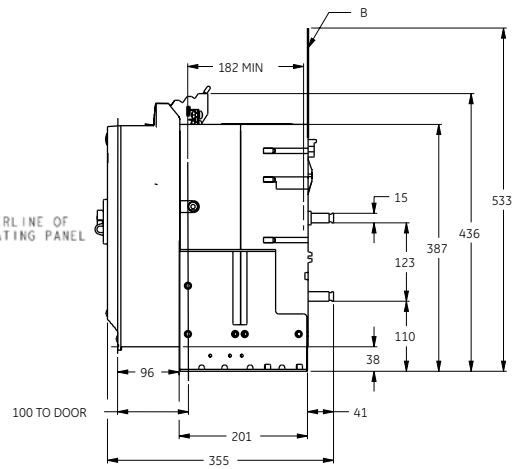

Top view 4 pole

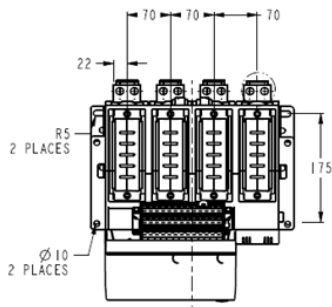

Top view 3 pole

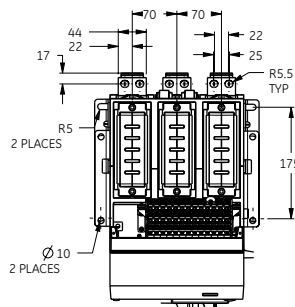

Door cut-out

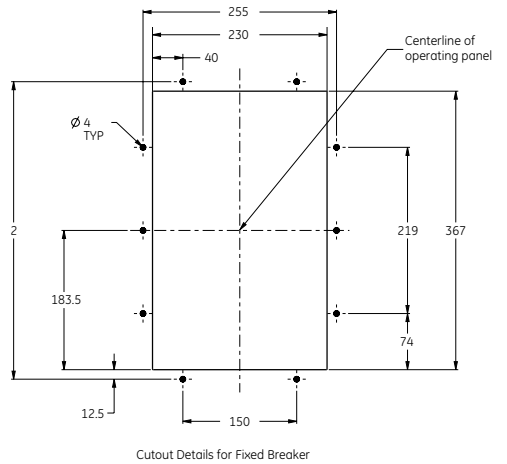

Standard connection Pads

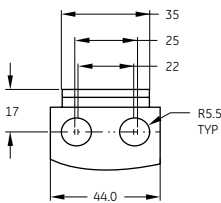

**Remarks:**

B – Minimum space to earth metal and for insulated metal or insulate sheet (30mm). The 182 min dimension is to allow for Arc Chute removal.

**Note:**

Copper work used to connect must be supported within 200mm of the breaker connections.  
Applicable for: busbar or cables.  
All busbar connections to be tightened to 50Nm torque.





Frame T – Draw-out pattern (universal)

Frame T

Front view 4 pole

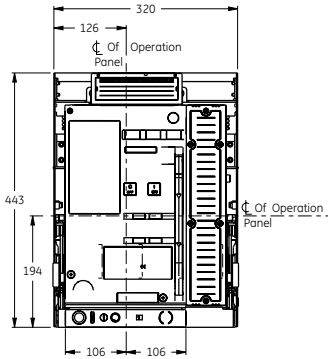

Front view 3 pole

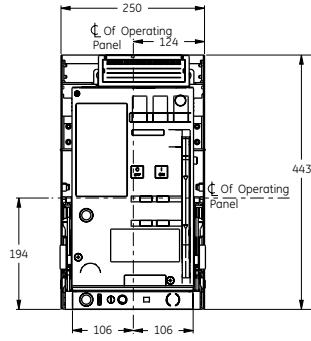

Side view

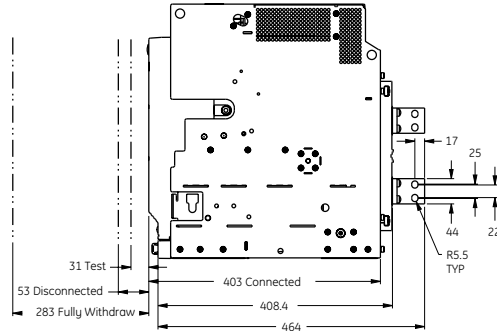

Bottom view 4 pole

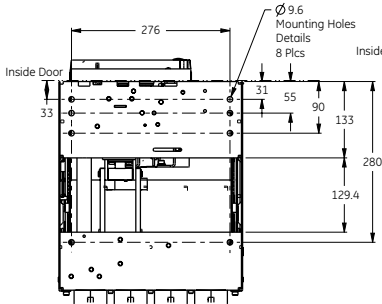

Bottom view 3 pole

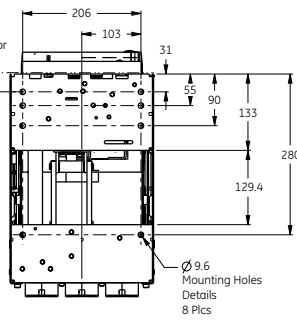

Door cut-out

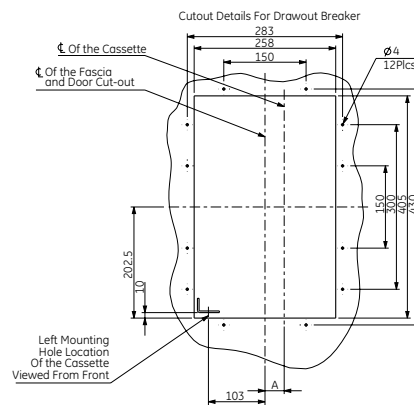

Universal connection pads  
Mounted horizontally or vertically

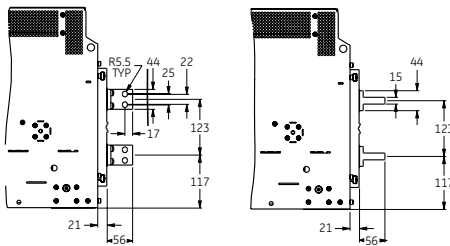

Breaker type	DIM "A"
Frame T 3 pole	0.0
Frame T 4 pole	35.0

Universal connection pads  
Details

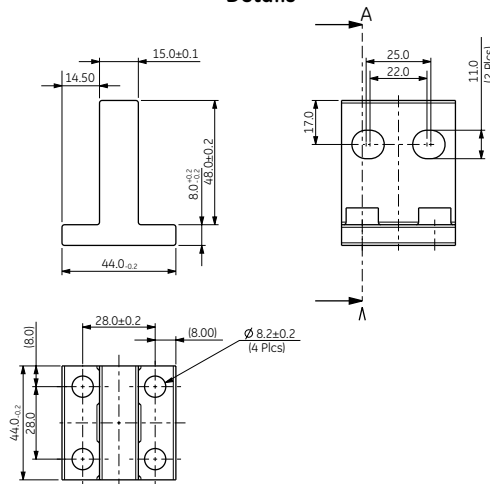

Remarks:

A – 6 mounting holes of 9.5mm

Note:

Copper work used to connect must be supported within 200mm of the breaker connections.  
Applicable for: busbar or cables.  
All busbar connections to be tightened to 50Nm torque.

Intro

A

B

C

D

E

F

X





Frame T – Alternate connection modes

Fixed vertical rear connection

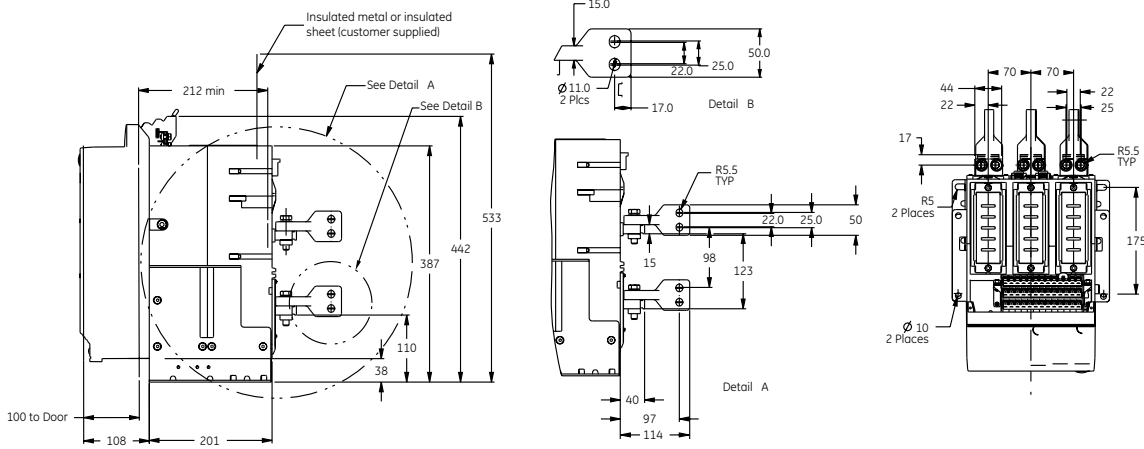

Fixed front connection

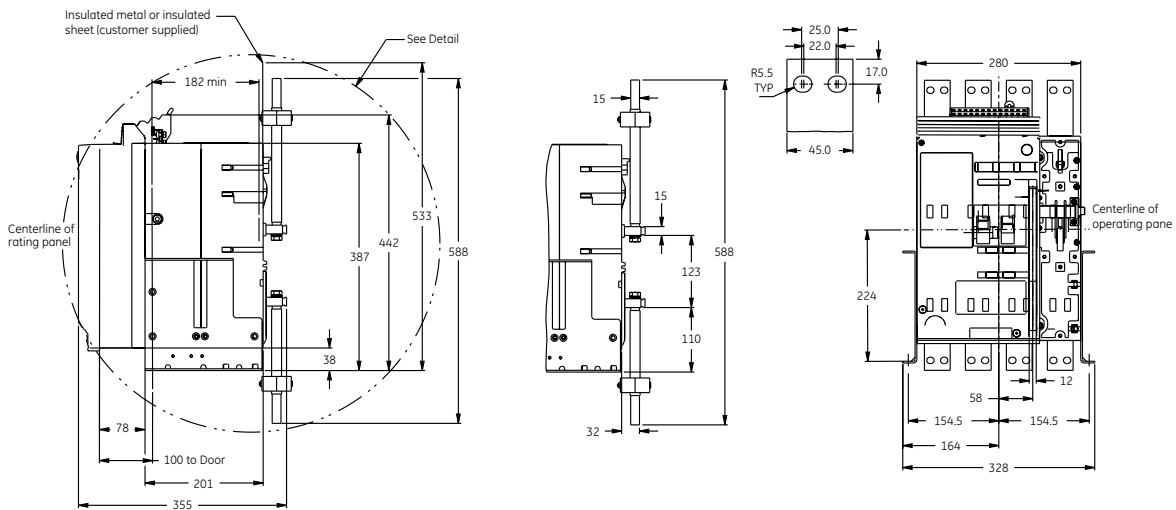

Draw-out front connection  
4 pole

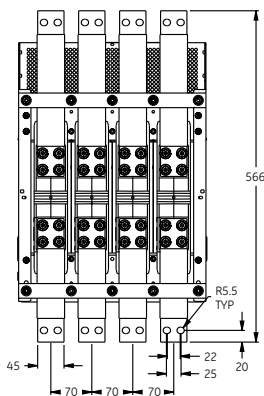

Draw-out front connection  
3 pole

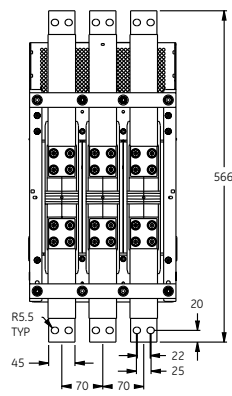

Draw-out front connection  
Side view

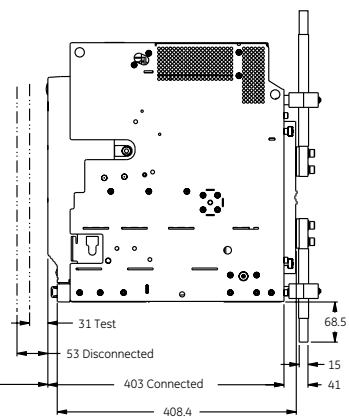

Frame T

Intro

A

B

C

D

E

F

X





Frame 1 - Draw-out pattern

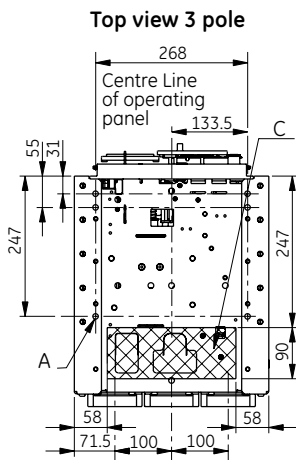
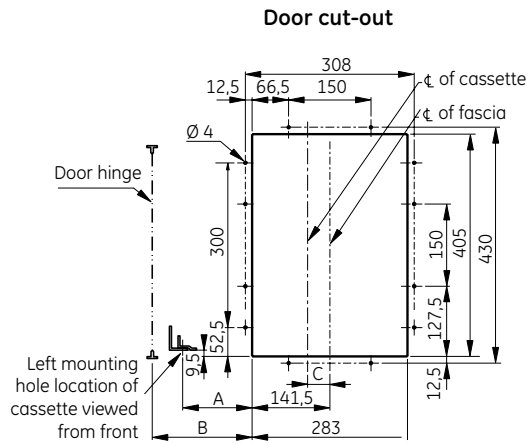
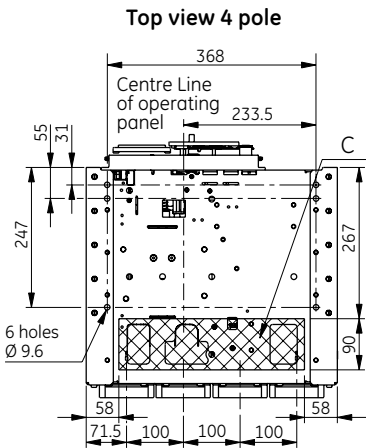
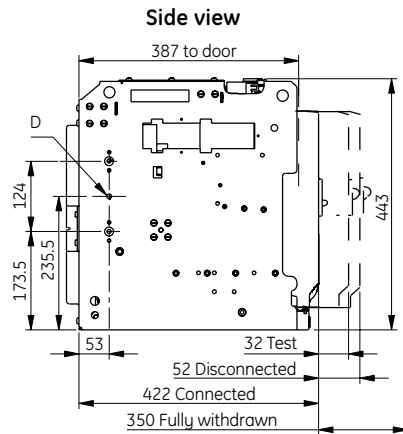
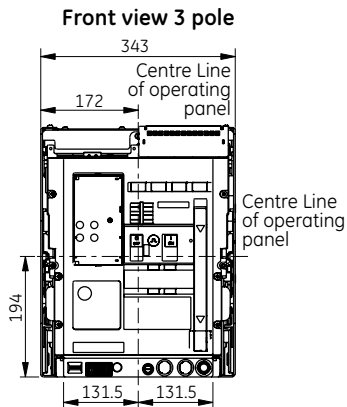
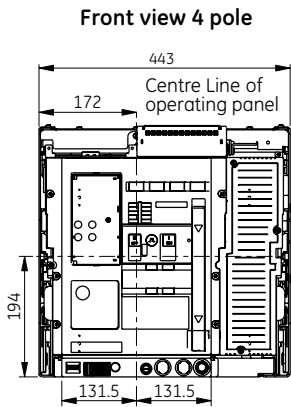

Breaker type	DIM "A"	DIM "B" minimum	DIM "C"
Frame 1 3 pole	-7.0	60.0	0.0
Frame 1 4 pole	-7.0	60.0	-49.5

Remarks:

- A - 6 mounting holes of 9.5mm
- C - Please leave unobstructed; required for ventilation
- D - 1 hole M6 on left hand side for earthing

Note:

Copper work used to connect must be supported within 200mm of the breaker connections.  
 Applicable for: busbar or cables.  
 All busbar connections to be tightened to 50Nm torque.

## Frame 1 - Draw-out pattern

### Universal connection pads Vertical or horizontal max. 1600A

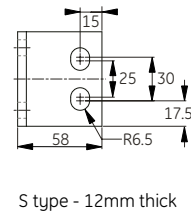
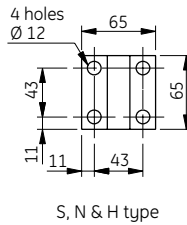
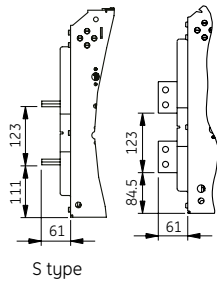

### Universal connection pads Vertical or horizontal max. 2000A

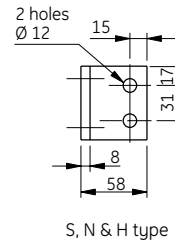
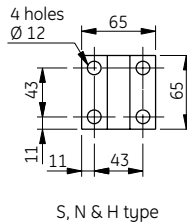
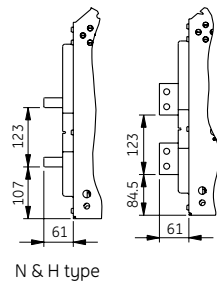

### Universal connection pads Only vertical max. 2500A

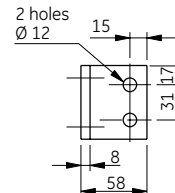
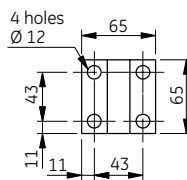
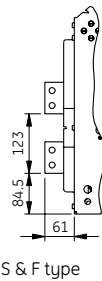

## Frame 1 - Draw-out pattern - Special vertical terminal

### Vertical connection pad

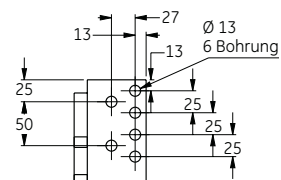
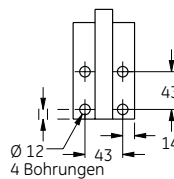
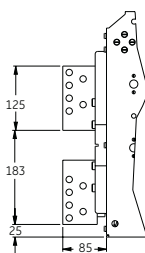







Frame 2 - "Limited derating" draw-out type

Front view 4 pole

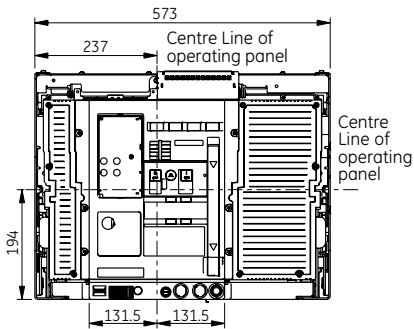

Front view 3 pole

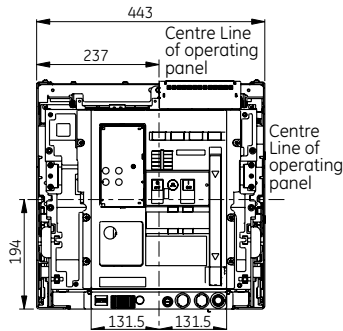

Side view

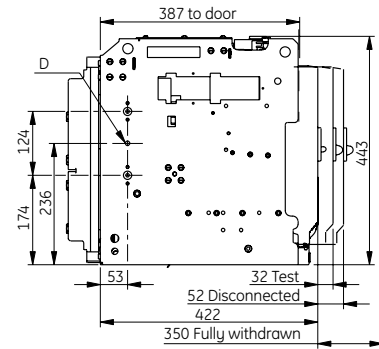

Top view 4 pole

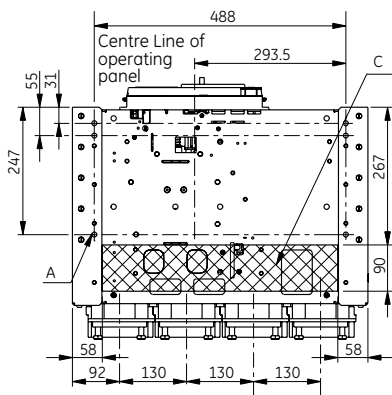

Top view 3 pole

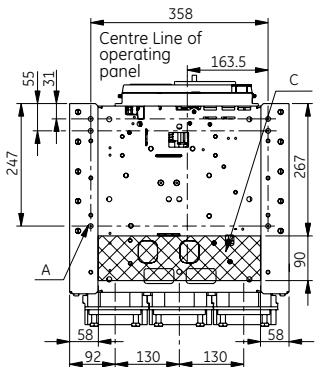

Door cut-out

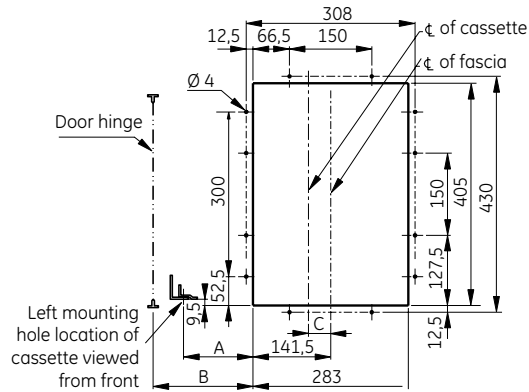

Breaker type	DIM "A"	DIM "B" minimum	DIM "C"
Frame 2 3 pole	53,0	125,0	15,5
Frame 2 4 pole	53,0	125,0	-49,5

Universal connection pads  
Vertical max. 4000A

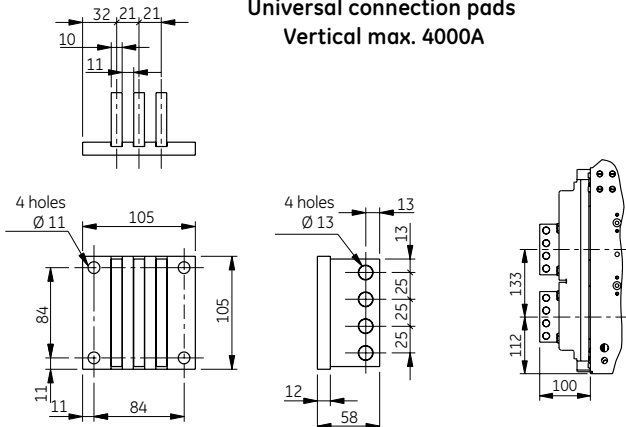

Remarks:

- A - 6 mounting holes of 9.5mm
- C - Please leave unobstructed; required for ventilation
- D - 1 hole M6 on left hand side for earthing

Note:

Copper work used to connect must be supported within 200mm of the breaker connections.  
Applicable for: busbar or cables.  
All busbar connections to be tightened to 50Nm torque.



## Frames 1 and 2 - Alternate connection modes

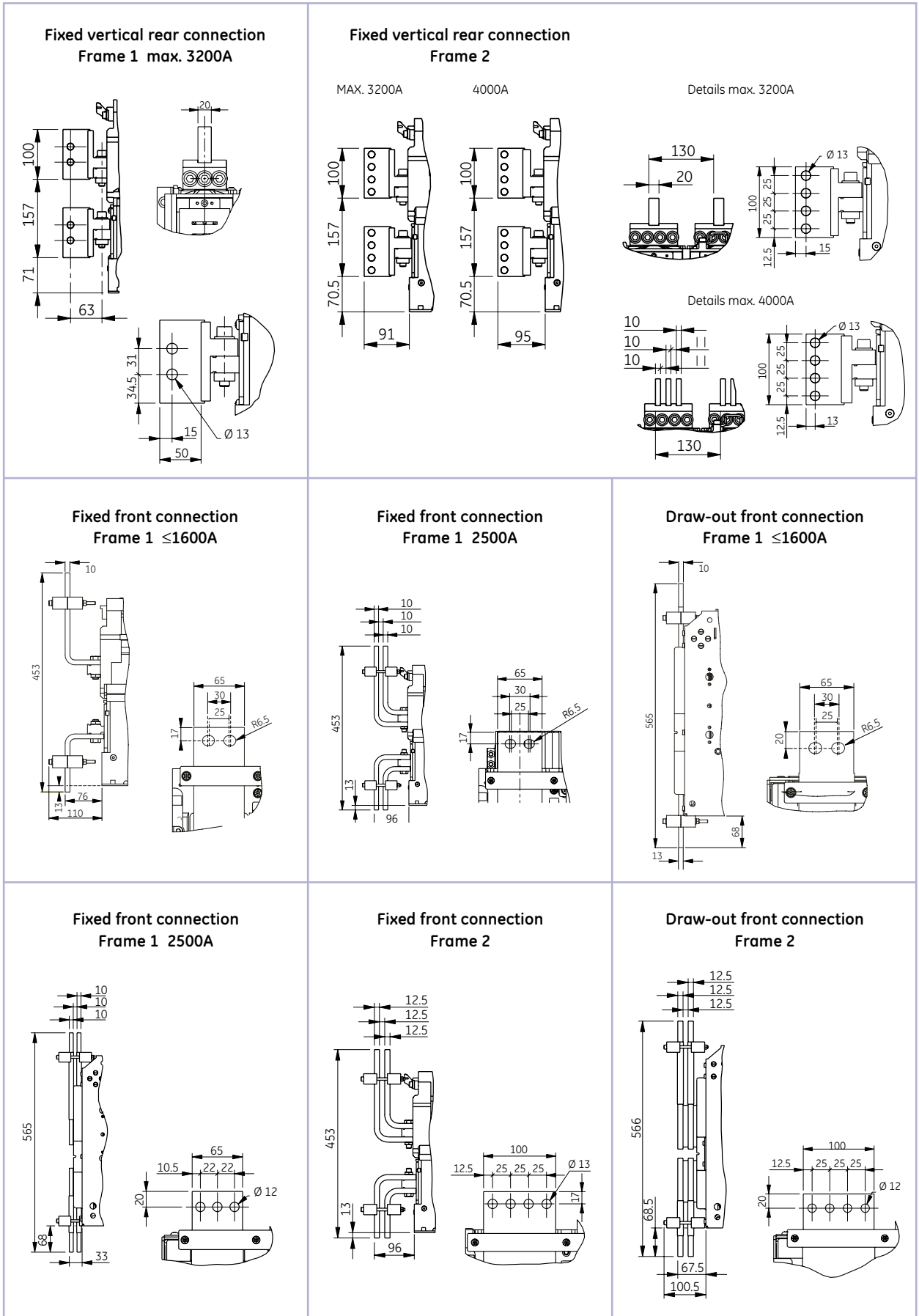

Frame 3 - Fixed type

Front view 4 pole

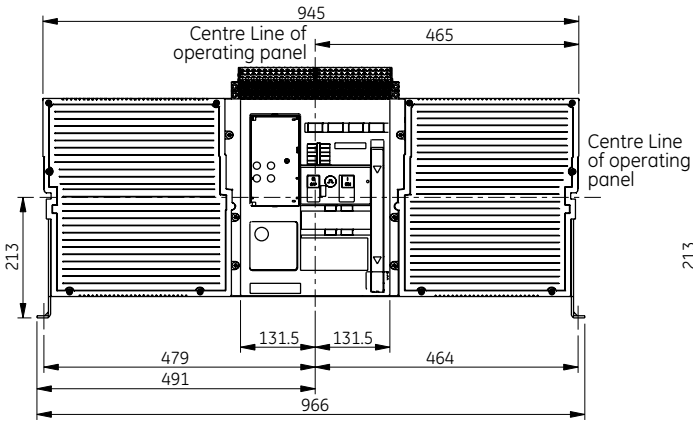

Front view 3 pole

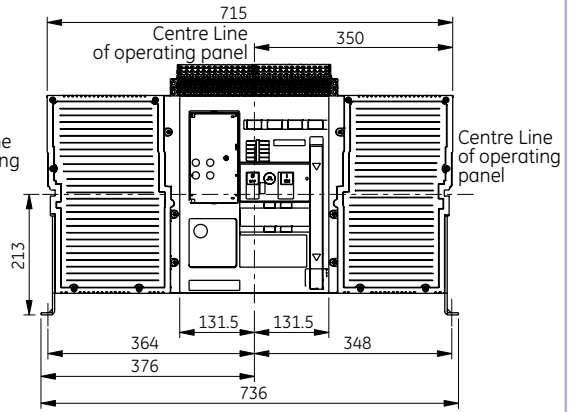

Top view 4 pole

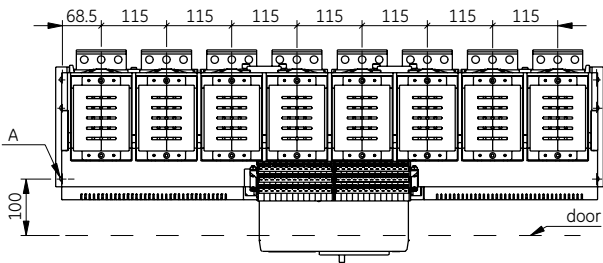

Top view 3 pole

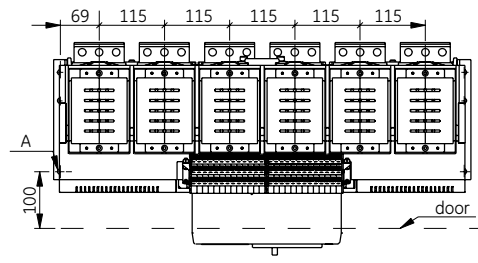

## Frame 3 - Fixed type

Side view

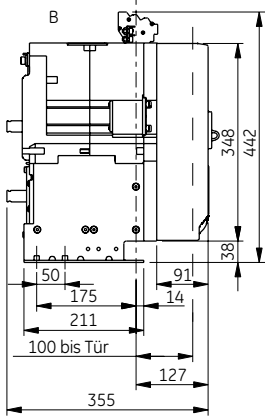

Door cut-out

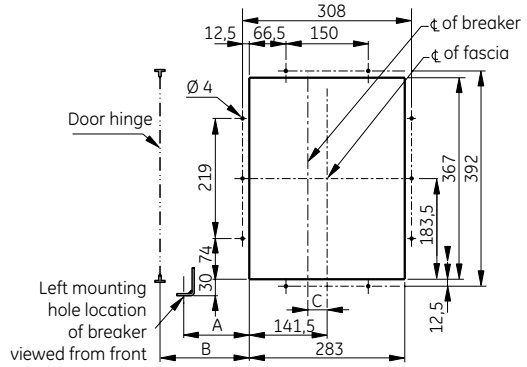

Breaker type	DIM "A"	DIM "B" minimum	DIM "C"
Frame 3 3 pole	222.5	259.5	8.0
Frame 3 4 pole	337.5	374.5	8.0

Standard connection pads  
Horizontal maximum 5000A

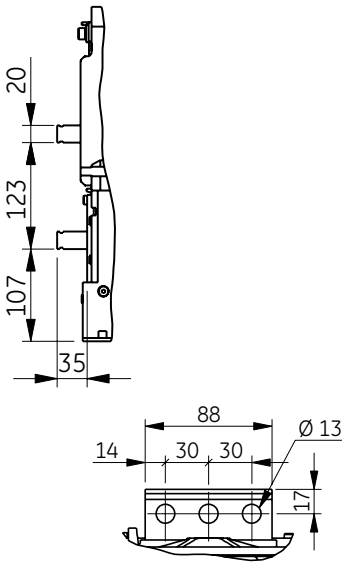

Standard connection pads  
Vertical maximum 6400A

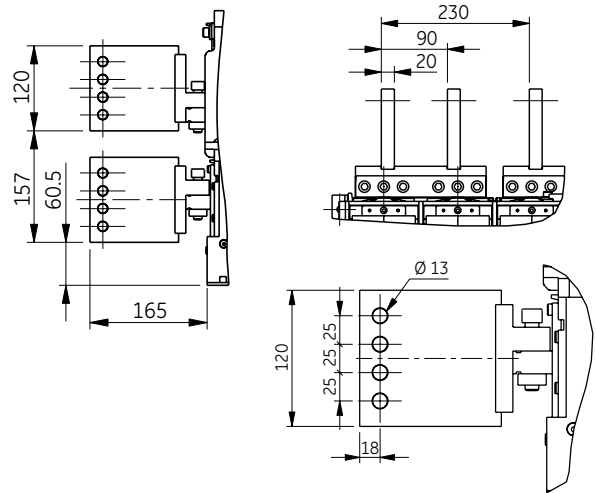

**Remarks:**

- A - 6 mounting holes of 9.5mm
- B - Minimum space to earth metal and for insulated metal or insulate sheet (30mm).  
The 182 min dimension is to allow for Arc Chute removal.

**Note:**

- Copper work used to connect must be supported within 200mm of the breaker connections.
- Applicable for: busbar or cables.
- All busbar connections to be tightened to 50Nm torque.

Frame 3 - Draw-out pattern

Front view 4 pole

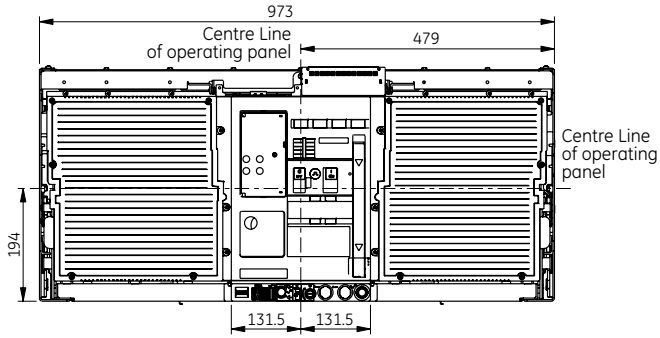

Front view 3 pole

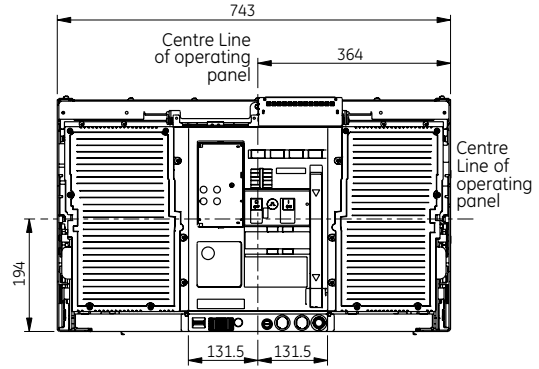

Top view 4 pole

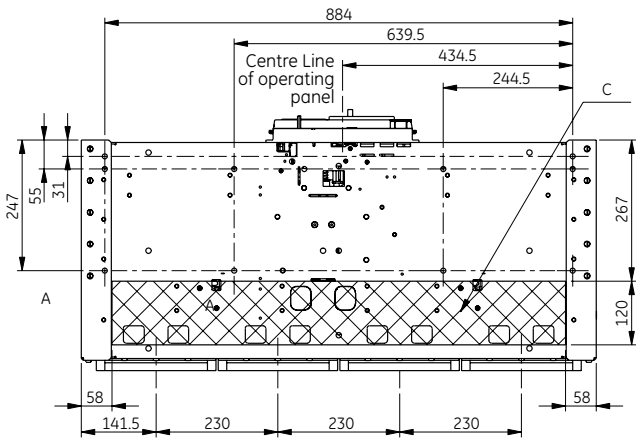

Top view 3 pole

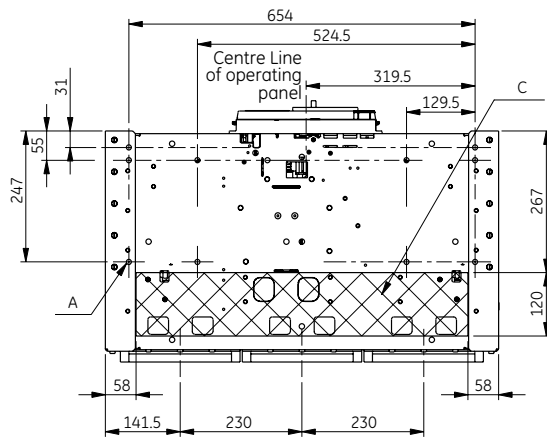

Frame 3

Intro

A

B

C

D

E

F

X





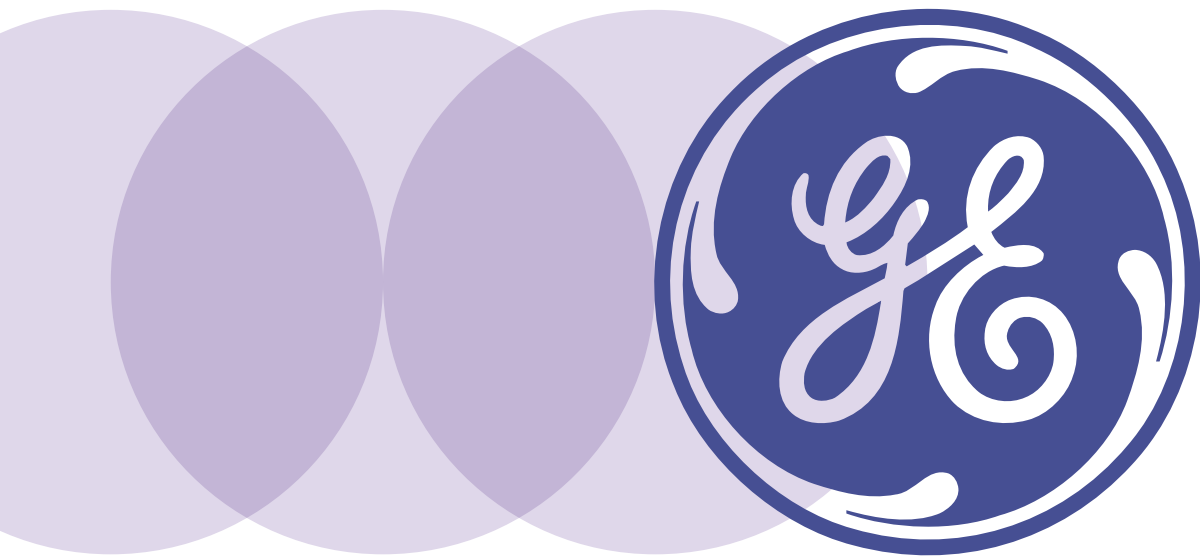

## IP54 Flange, time delay module UVR, 24V power supply

IP54 Flange

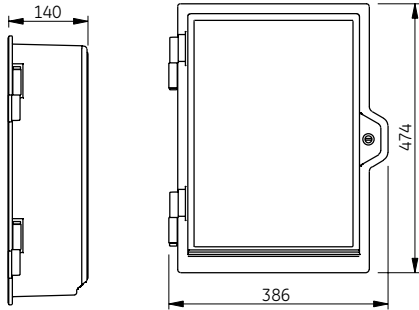

IP54 Flange drilling

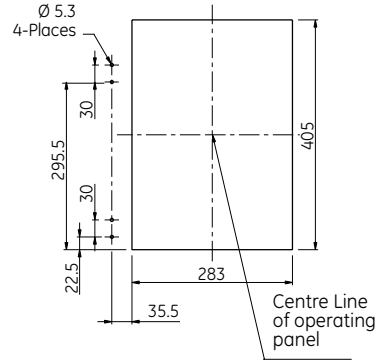

Time delay module (UVR)

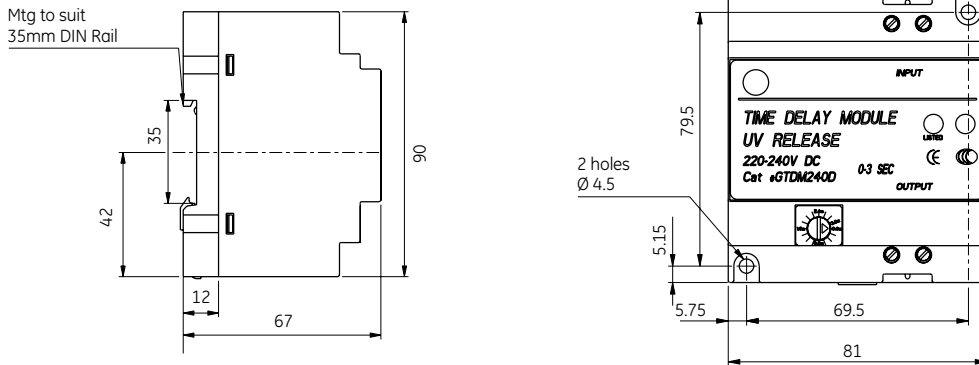

External 24V DC power supply

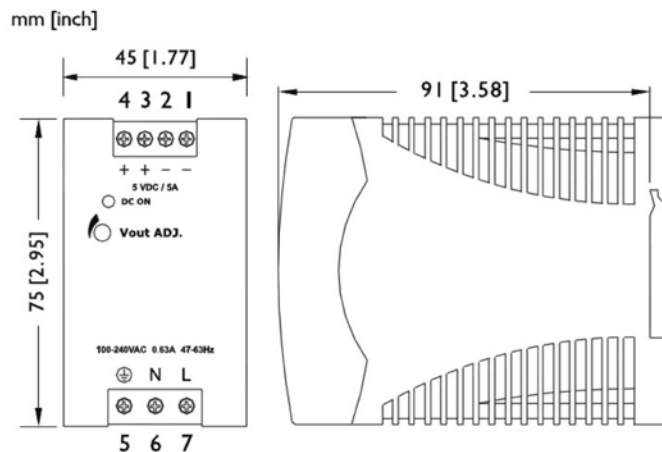



Rogowski's, current transformers, door interlock system and mounting brackets

Rogowski coil external

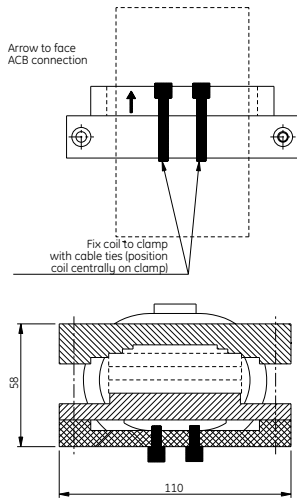

Current transformer external

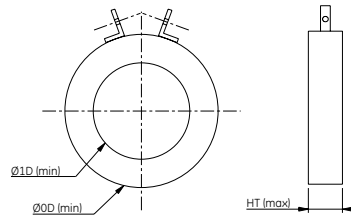

Rating	1D	OD	HT
400A	94	144	24
630A	85	135	30
2000A	87	151	31
3200A	84	154	34
4000A	81	154	57
5000A	85	198	58
6400A	85	210	65

Door interlock system

Frame T

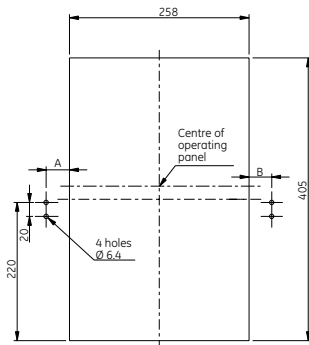

Frame	A & B
3P	30
4P	100

Frame 1/2/3

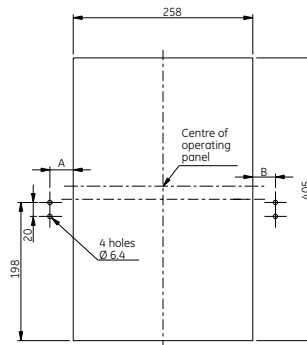

Frame	A	B
F1-3P	33.5	32.5
F1-4P	33.5	132.5
F2-3P	98.5	67.5
F2-4P	98.5	197.5
F3-3P	240.5	225.5
F3-4P	355.5	340.5

Front mounting brackets (fixed pattern, drawings include front connection option)

Frame 1

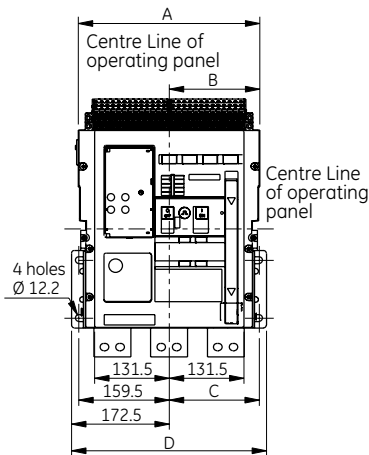

Frame 2

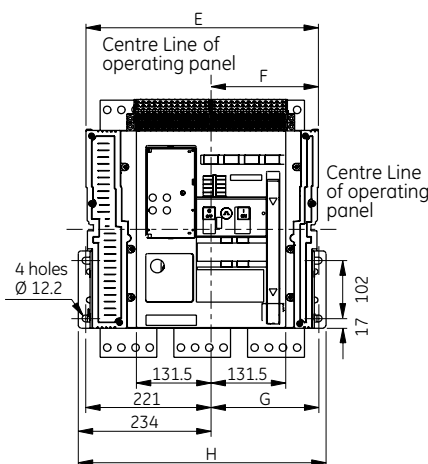

	3 pole	4 pole
A	320	420
B	159.5	259.5
C	158.5	258.5
D	344	444
E	410	540
F	189.5	319.5
G	190	320
H	437	567



## Interlocking with cable systems; 2-way

Dimensions

Fixed pattern 2-way cable interlock / Fixed pattern - Front/rear access

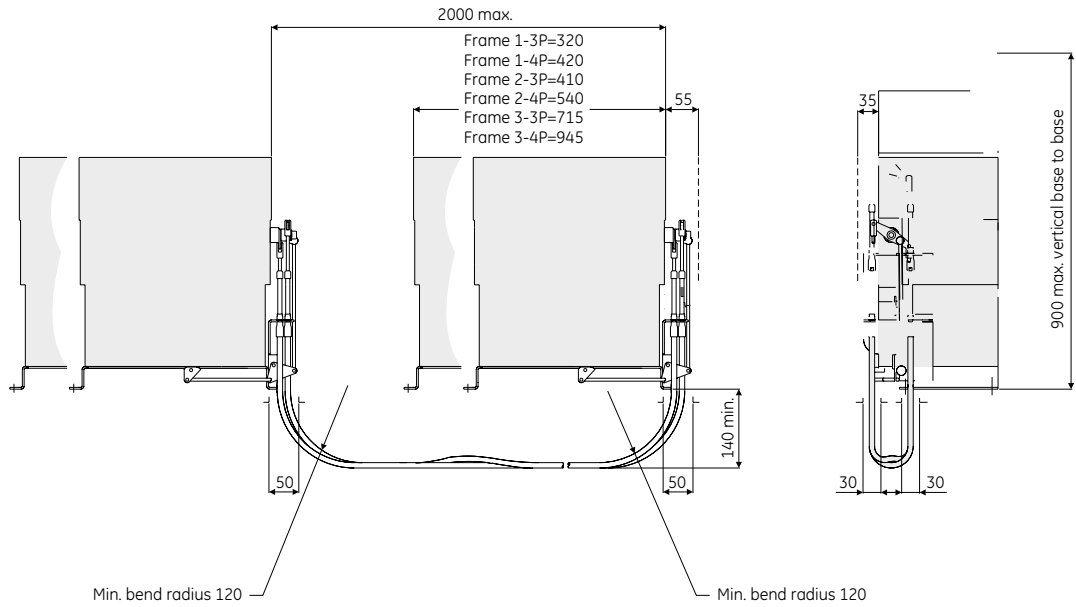

Draw-out 2-way cable interlock / Withdrawable pattern - Front/rear access

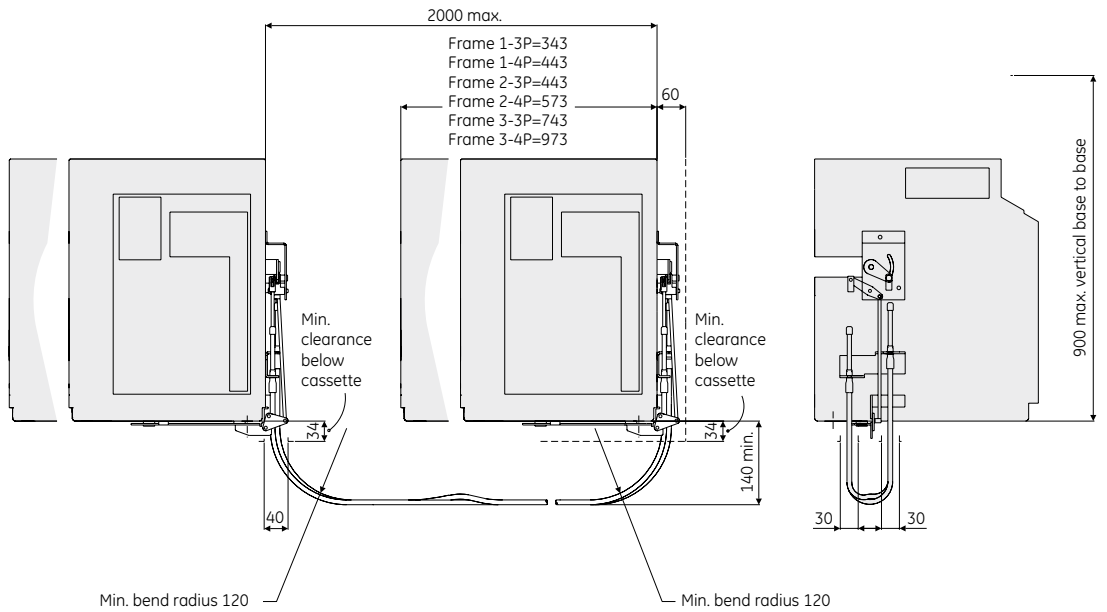

- Dimensions
- Intro
- A
- B
- C
- D
- E
- F
- X

Interlocking with cable systems; 3-way

Fixed pattern 3-way cable interlock / Fixed pattern - Front/rear access

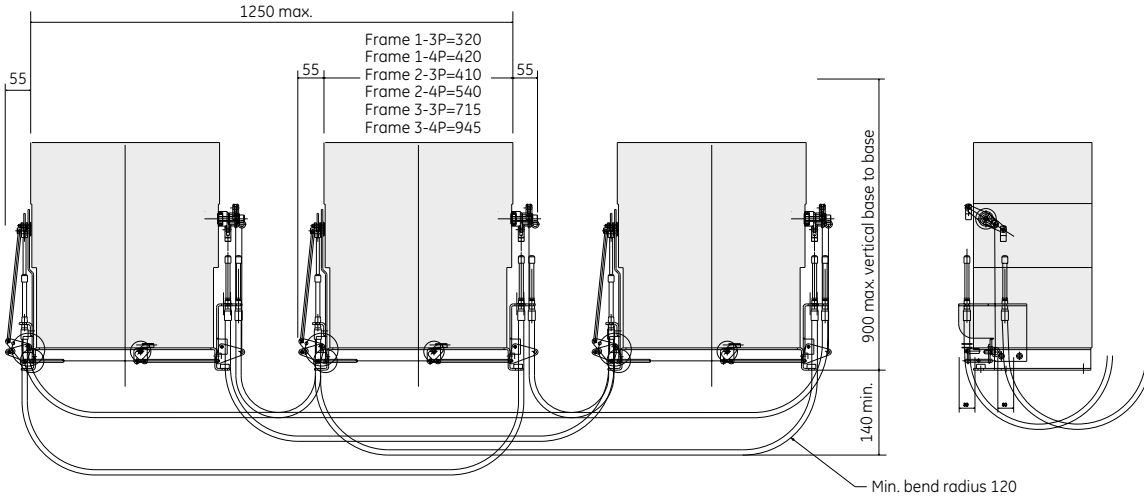

Draw-out 3-way cable interlock / Withdrawable pattern - Front/rear access

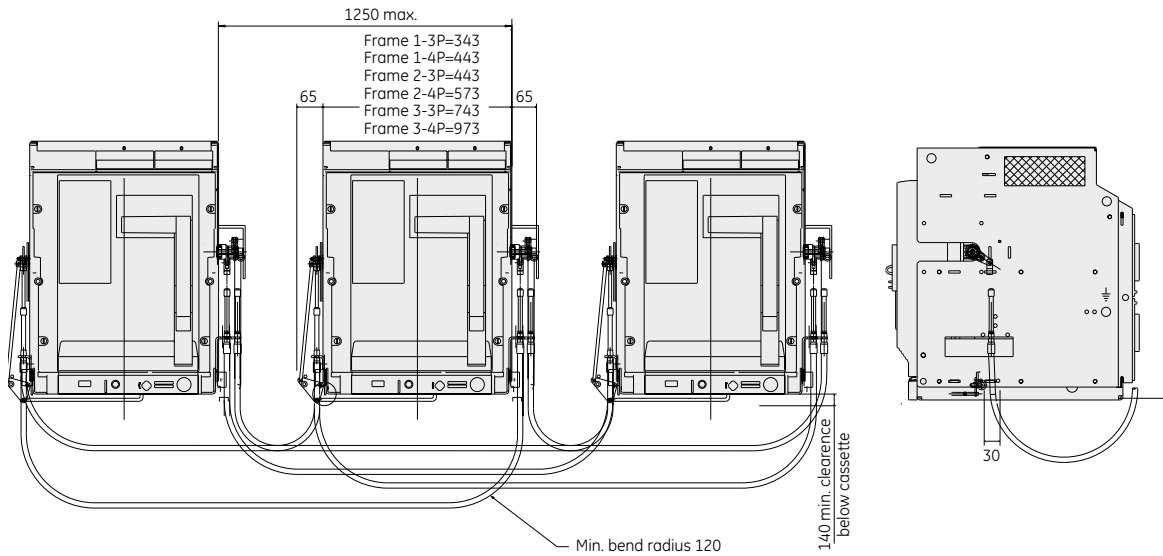

## By reference number

Ref. No.	Cat. No.	Page	Ref. No.	Cat. No.	Page	Ref. No.	Cat. No.	Page	Ref. No.	Cat. No.	Page
287000			407121	GG13E3	A.9	407267	GG32N6	A.4	407461	GJ13S6	A.6
287030	GGDEFD	A.27	407122	GG13E4	A.4	407268	GG40G1	A.10	407474	GW16N1	A.12
287031	GTDEDT	A.27	407123	GG13E6	A.4	407269	GG40G3	A.10	407475	GW16N3	A.12
287032	GTDEFD	A.27	407124	GG13H1	A.9	407270	GG40G4	A.5	407476	GW16N4	A.6
407000			407125	GG13H3	A.9	407271	GG40G6	A.5	407477	GW16N6	A.6
407001	GG04E1	A.9	407126	GG13H4	A.4	407273	GG32H3	A.9	407478	GJ16S1	A.12
407002	GG04E3	A.9	407127	GG13H6	A.4	407278	GG40H1	A.9	407479	GJ16S3	A.12
407003	GG04E4	A.4	407128	GG13M1	A.10	407279	GG40H3	A.9	407480	GJ16S4	A.6
407004	GG04E6	A.4	407129	GG13M3	A.10	407280	GG40H4	A.4	407481	GJ16S6	A.6
407005	GG04H1	A.9	407130	GG13M4	A.5	407281	GG40H6	A.4	407494	GW20N1	A.12
407006	GG04H3	A.9	407131	GG13M6	A.5	407282	GG40L1	A.10	407495	GW20N3	A.12
407007	GG04H4	A.4	407132	GG13N1	A.9	407283	GG40L3	A.10	407496	GW20N4	A.6
407008	GG04H6	A.4	407133	GG13N3	A.9	407284	GG40L4	A.5	407497	GW20N6	A.6
407009	GG04M1	A.10	407134	GG13N4	A.4	407285	GG40L6	A.5	407498	GJ20S1	A.12
407010	GG04M3	A.10	407135	GG13N6	A.4	407286	GG40M1	A.10	407499	GJ20S3	A.12
407011	GG04M4	A.5	407136	GG13S1	A.9	407287	GG40M3	A.10	407500	GJ20S4	A.6
407012	GG04M6	A.5	407137	GG13S3	A.9	407288	GG40M4	A.5	407501	GJ20S6	A.6
407013	GG04N1	A.9	407138	GG13S4	A.4	407289	GG40M6	A.5	407518	GJ25N1	A.12
407014	GG04N3	A.9	407139	GG13S6	A.4	407290	GG40N1	A.9	407519	GJ25N3	A.12
407015	GG04N4	A.4	407150	GG16E1	A.9	407291	GG40N3	A.9	407520	GJ25N4	A.6
407016	GG04N6	A.4	407151	GG16E3	A.9	407292	GG40N4	A.4	407521	GJ25N6	A.6
407017	GG04S1	A.9	407152	GG16E4	A.4	407293	GG40N6	A.4	407533	GJ32L1	A.12
407018	GG04S3	A.9	407153	GG16E6	A.4	407300	GG50L1	A.10	407534	GJ32L3	A.12
407019	GG04S4	A.4	407154	GG16H1	A.9	407301	GG50L3	A.10	407535	GJ32L4	A.6
407020	GG04S6	A.4	407155	GG16H3	A.9	407302	GG50L4	A.5	407536	GJ32L6	A.6
407030	GG07E1	A.9	407156	GG16H4	A.4	407303	GG50L6	A.5	407537	GJ32N1	A.12
407031	GG07E3	A.9	407157	GG16H6	A.4	407304	GG50M1	A.10	407538	GJ32N3	A.12
407032	GG07E4	A.4	407158	GG16M1	A.10	407305	GG50M3	A.10	407539	GJ32N4	A.6
407033	GG07E6	A.4	407159	GG16M3	A.10	407306	GG50M4	A.5	407540	GJ32N6	A.6
407034	GG07H1	A.9	407160	GG16M4	A.5	407307	GG50M6	A.5	407554	GJ40L1	A.12
407035	GG07H3	A.9	407161	GG16M6	A.5	407320	GG64L1	A.10	407555	GJ40L3	A.12
407036	GG07H4	A.4	407162	GG16N1	A.9	407321	GG64L3	A.10	407556	GJ40L4	A.6
407037	GG07H6	A.4	407163	GG16N3	A.9	407322	GG64L4	A.5	407557	GJ40L6	A.6
407038	GG07M1	A.10	407164	GG16N4	A.4	407323	GG64L6	A.5	407558	GJ40N1	A.12
407039	GG07M3	A.10	407165	GG16N6	A.4	407324	GG64M1	A.10	407559	GJ40N3	A.12
407040	GG07M4	A.5	407166	GG16S1	A.9	407325	GG64M3	A.10	407560	GJ40N4	A.6
407041	GG07M6	A.5	407167	GG16S3	A.9	407326	GG64M4	A.5	407561	GJ40N6	A.6
407042	GG07N1	A.9	407168	GG16S4	A.4	407327	GG64M6	A.5	407565	GJ50L1	A.12
407043	GG07N3	A.9	407169	GG16S6	A.4	407346	GH32H1	A.11	407566	GJ50L3	A.12
407044	GG07N4	A.4	407190	GG20E1	A.9	407347	GH32H3	A.11	407567	GJ50L4	A.6
407045	GG07N6	A.4	407191	GG20E3	A.9	407348	GH32M1	A.11	407568	GJ50L6	A.6
407046	GG07S1	A.9	407192	GG20E4	A.4	407349	GH32M3	A.11	407575	GJ64L1	A.12
407047	GG07S3	A.9	407193	GG20E6	A.4	407350	GH32N1	A.11	407576	GJ64L3	A.12
407048	GG07S4	A.4	407194	GG20H1	A.9	407351	GH32N3	A.11	407577	GJ64L4	A.6
407049	GG07S6	A.4	407195	GG20H3	A.9	407352	GH40H1	A.11	407578	GJ64L6	A.6
407055	GCPSA	A.22	407196	GG20H4	A.4	407353	GH40H3	A.11	407589	GZ32H1	A.13
407056	GCPSAR	A.24	407197	GG20H6	A.4	407354	GH40M1	A.11	407590	GZ32H3	A.13
407060	GG08E1	A.9	407198	GG20M1	A.10	407355	GH40M3	A.11	407591	GK32N1	A.13
407061	GG08E3	A.9	407199	GG20M3	A.10	407356	GH40N1	A.11	407592	GK32N3	A.13
407062	GG08E4	A.4	407200	GG20M4	A.5	407357	GH40N3	A.11	407593	GZ40H1	A.13
407063	GG08E6	A.4	407201	GG20M6	A.5	407374	GW04N1	A.12	407594	GZ40H3	A.13
407064	GG08H1	A.9	407202	GG20N1	A.9	407375	GW04N3	A.12	407595	GK40N1	A.13
407065	GG08H3	A.9	407203	GG20N3	A.9	407376	GW04N4	A.6	407596	GK40N3	A.13
407066	GG08H4	A.4	407204	GG20N4	A.4	407377	GW04N6	A.6	407606	GZ0H2SSL	A.33
407067	GG08H6	A.4	407205	GG20N6	A.4	407378	GJ04S1	A.12	407607	GZ0H5SSL	A.33
407068	GG08M1	A.10	407206	GG20S1	A.9	407379	GJ04S3	A.12	407610	GG16H2FXXXXR	A.29
407069	GG08M3	A.10	407207	GG20S3	A.9	407380	GJ04S4	A.6	407612	GG16H2UXXXXR	A.29
407070	GG08M4	A.5	407208	GG20S4	A.4	407381	GJ04S6	A.6	407613	GG16H5FXXXXR	A.29
407071	GG08M6	A.5	407209	GG20S6	A.4	407394	GW07N1	A.12	407615	GG16H5UXXXXR	A.29
407072	GG08N1	A.9	407230	GG25H1	A.9	407395	GW07N3	A.12	407616	GG16S2UXXXXM	A.14
407073	GG08N3	A.9	407231	GG25H3	A.9	407396	GW07N4	A.6	407617	GG16S2UXXXXM	A.29
407074	GG08N4	A.4	407232	GG25H4	A.4	407397	GW07N6	A.6	407618	GG16S5UXXXXM	A.14
407075	GG08N6	A.4	407233	GG25H6	A.4	407398	GJ07S1	A.12	407619	GG16S5UXXXXM	A.29
407076	GG08S1	A.9	407234	GG25M1	A.10	407399	GJ07S3	A.12	407620	GG20H2FXXXXR	A.29
407077	GG08S3	A.9	407235	GG25M3	A.10	407400	GJ07S4	A.6	407622	GG20H2UXXXXR	A.29
407078	GG08S4	A.4	407236	GG25M4	A.5	407401	GJ07S6	A.6	407623	GG20H5FXXXXR	A.29
407079	GG08S6	A.4	407237	GG25M6	A.5	407414	GW08N1	A.12	407625	GG20H5UXXXXR	A.29
407088	GCPS5R	A.24	407238	GG25N1	A.9	407415	GW08N3	A.12	407626	GG16S2FXXXXM	A.15
407090	GG10E1	A.9	407239	GG25N3	A.9	407416	GW08N4	A.6	407627	GG16S2FXXXXR	A.29
407091	GG10E3	A.9	407240	GG25N4	A.4	407417	GW08N6	A.6	407628	GG16S5FXXXXM	A.15
407092	GG10E4	A.4	407241	GG25N6	A.4	407418	GJ08S1	A.12	407629	GG16S5FXXXXR	A.29
407093	GG10E6	A.4	407242	GG32H1	A.9	407419	GJ08S3	A.12	407630	GG20M2FXXXXR	A.29
407094	GG10H1	A.9	407244	GG32H4	A.4	407420	GJ08S4	A.6	407632	GG20M2UXXXXR	A.29
407095	GG10H3	A.9	407245	GG32H6	A.4	407421	GJ08S6	A.6	407633	GG20M5FXXXXR	A.29
407096	GG10H4	A.4	407248	GG32L1	A.10	407434	GW10N1	A.12	407635	GG20M5UXXXXR	A.29
407097	GG10H6	A.4	407249	GG32L3	A.10	407435	GW10N3	A.12	407636	G40M2SSL	A.33
407098	GG10M1	A.10	407250	GG32G1	A.10	407436	GW10N4	A.6	407637	G40M5SSL	A.33
407099	GG10M3	A.10	407251	GG32G3	A.10	407437	GW10N6	A.6	407640	GG25M2FXXXXR	A.29
407100	GG10M4	A.5	407252	GG32G4	A.5	407438	GJ10S1	A.12	407642	GG25M2UXXXXR	A.29
407101	GG10M6	A.5	407253	GG32G6	A.5	407439	GJ10S3	A.12	407643	GG25M5FXXXXR	A.29
407102	GG10N1	A.9	407254	GG32L4	A.5	407440	GJ10S4	A.6	407645	GG25M5UXXXXR	A.29
407103	GG10N3	A.9	407255	GG32L6	A.5	407441	GJ10S6	A.6	407650	GG32M2FXXXXR	A.29
407104	GG10N4	A.4	407260	GG32M1	A.10	407454	GW13N1	A.12	407652	GG32M2UXXXXR	A.29
407105	GG10N6	A.4	407261	GG32M3	A.10	407455	GW13N3	A.12	407654	GG32M5FXXXXR	A.29
407106	GG10S1	A.9	407262	GG32M4	A.5	407456	GW13N4	A.6	407656	GG32M5UXXXXR	A.29
407107	GG10S3	A.9	407263	GG32M6	A.5	407457	GW13N6	A.6	407658	GG40M2FXXXXR	A.29
407108	GG10S4	A.4	407264	GG32N1	A.9	407458	GJ13S1	A.12	407666	GG40M2UXXXXR	A.29
407109	GG10S6	A.4	407265	GG32N3	A.9	407459	GJ13S3	A.12	407668	GG40M5FXXXXR	A.29
407120	GG13E1	A.9	407266	GG32N4	A.4	407460	GJ13S4	A.6	407670	GG40M5UXXXXR	A.29

Numerical index

Intro

A

B

C

D

E

F

X



Ref. No.	Cat. No.	Page
407676	GG25F5VXXXXM	A.14
407679	G64L2SSL	A.33
407680	G64L5SSL	A.33
407686	GG64L2UXXXXR	A.29
407688	GG64L5UXXXXR	A.29
407700	GM01024D	A.22
407701	GM01024DR	A.24
407702	GM01048D	A.22
407703	GM01048DR	A.24
407704	GM01060D	A.22
407705	GM01060DR	A.24
407706	GM01110D	A.22
407707	GM01110DR	A.24
407708	GM01250D	A.22
407709	GM01250DR	A.24
407710	GM01048A	A.22
407711	GM01048AR	A.24
407712	GM01120A	A.22
407713	GM01120AR	A.24
407714	GM01240A	A.22
407715	GM01240AR	A.24
407716	GM01400AR	A.22
407717	GM01400DR	A.24
407718	GM01440A	A.22
407719	GM01440AR	A.24
407720	GM01220D	A.22
407721	GM01220DR	A.24
407722	GM02220D	A.22
407723	GM02220DR	A.24
407725	GM02024D	A.22
407726	GM02024DR	A.24
407727	GM02048D	A.22
407728	GM02048DR	A.24
407729	GM02060D	A.22
407730	GM02060DR	A.24
407731	GM02110D	A.22
407732	GM02110DR	A.24
407733	GM02250D	A.22
407734	GM02250DR	A.24
407735	GM02048A	A.22
407736	GM02048DR	A.24
407737	GM02120A	A.22
407738	GM02120DR	A.24
407739	GM02240A	A.22
407740	GM02240DR	A.24
407741	GM02400A	A.22
407742	GM02400DR	A.24
407743	GM02440A	A.22
407744	GM02440DR	A.24
407753	GNTK120	A.22
407754	GNTK240	A.22
407760	GRRC024D	A.22
407762	GRRC110	A.22
407764	GRRC230	A.22
407770	GSTRO24D	A.22
407771	GSTRO24DR	A.24
407772	GSTRO48	A.22
407773	GSTRO48R	A.24
407774	GSTRO60D	A.22
407775	GSTRO60DR	A.24
407776	GSTR120	A.22
407777	GSTR120R	A.24
407778	GSTR240	A.22
407779	GSTR240R	A.24
407780	GSTR277	A.22
407781	GSTR277R	A.24
407782	GSTR400A	A.22
407783	GSTR400AR	A.24
407784	GSTR440A	A.22
407785	GSTR440AR	A.24
407786	GSTRO30D	A.22
407787	GSTRO30DR	A.24
407789	GSST024	A.22
407790	GSST024R	A.24
407791	GSST120	A.22
407792	GSST120R	A.24
407793	GSST240	A.22
407794	GSST240R	A.24
407795	GUVT024D	A.22
407796	GUVT024DR	A.24
407797	GUVT048	A.22
407798	GUVT048R	A.24
407799	GUVT060D	A.22
407800	GUVT060DR	A.24
407801	GUVT120	A.22
407802	GUVT120R	A.24
407803	GUVT240	A.22
407804	GUVT240R	A.24
407805	GUVT277	A.22

Ref. No.	Cat. No.	Page
407806	GUVT277R	A.24
407807	GUVT400A	A.22
407808	GUVT400AR	A.24
407809	GUVT440A	A.22
407810	GUVT440AR	A.24
407811	GUVR240	A.22
407812	GUVR240R	A.24
407816	GTDM048A	A.26
407817	GTDM060D	A.26
407818	GTDM120A	A.26
407819	GTDM120D	A.26
407820	GTDM240A	A.26
407821	GTDM240D	A.26
407822	GTDM277A	A.26
407823	GTDM250D	A.26
407824	GTDM400A	A.26
407825	GTDM440A	A.26
407835	GCCC024DR	A.24
407836	GCCC024D	A.22
407837	GCCC048R	A.24
407838	GCCC048	A.22
407839	GCCC060DR	A.24
407840	GCCC060D	A.22
407841	GCCC120R	A.24
407842	GCCC120	A.22
407843	GCCC240R	A.24
407844	GCCC240	A.22
407849	GCCC277	A.22
407850	GCCC277R	A.24
407851	GCCC400AR	A.24
407852	GCCC400A	A.22
407853	GCCC440A	A.22
407854	GCCC440AR	A.24
407860	GCCN024DR	A.24
407861	GCCN024D	A.22
407862	GCCN048R	A.24
407863	GCCN048	A.22
407864	GCCN060DR	A.24
407865	GCCN060D	A.22
407866	GCCN120R	A.24
407867	GCCN120	A.22
407868	GCCN240R	A.24
407869	GCCN240	A.22
407870	GCCN277	A.22
407871	GCCN277R	A.24
407876	GCCN400AR	A.24
407877	GCCN400A	A.22
407878	GCCN440A	A.22
407879	GCCN440AR	A.24
407880	GAS3R	A.24
407881	GAS5R	A.24
407882	GAS6R	A.24
407883	GAS8R	A.24
407885	GAS3	A.22
407886	GAS5	A.22
407887	GAS6	A.22
407888	GAS8	A.22
407889	GBAT1R	A.24
407890	GBATS1	A.22
407891	GBAT1	A.22
407894	GRTC3	A.22
407895	GCSP1	A.22
407896	GCSP2	A.22
407897	GRTC1	A.22
407899	GRTC2	A.22
407900	GI2FAD	A.23
407901	GI2WAD	A.23
407902	GI3FB	A.23
407903	GI3WB	A.23
407904	GI3FC	A.23
407905	GI3WC	A.23
407906	GI3FDT	A.23
407907	GI3WDT	A.23
407908	GRTC4	A.22
407909	GRTC5	A.22
407910	GRTC6	A.22
407915	GCSP1R	A.24
407916	GCSP2R	A.24
407922	GCPS1	A.22
407923	GCPS2	A.22
407924	GCPS1R	A.24
407925	GCPS2R	A.24
407930	G16H4ED	A.26
407931	G16H6ED	A.26
407932	G20H4ED	A.26
407933	G20H6ED	A.26
407934	G40M4ED	A.26
407935	G40M6ED	A.26
407936	G64M4ED	A.26

Ref. No.	Cat. No.	Page
407937	G64M6ED	A.26
407967	GBCASR	A.25
407968	GBRONR	A.25
407970	GBCAS	A.23
407971	GBRON	A.23
407974	GCRONR	A.25
407976	GCRON	A.23
407978	GBPRO	A.23
407979	GBPROR	A.25
407980	GCPRO	A.23
407981	GCPOR	A.25
407984	GRONCS	A.33
407986	GCAS	A.25
407987	GPRO	A.25
407990	GCB1	A.26
407991	GCB2	A.26
407992	GCB3	A.26
407993	GCB4	A.26
407994	GCB5	A.26
407995	GCB6	A.26
407996	GCB7	A.26
407999	GTUTK20	A.26
408000	G04HNRC	A.28
408001	G07HNRC	A.28
408002	G08HNRC	A.28
408003	G10HNRC	A.28
408004	G13HNRC	A.28
408005	G16HNRC	A.28
408006	G20HNRC	A.28
408025	GDPRF	A.27
408026	GDPRW	A.27
408028	GFA4	A.33
408030	GSDFTR2	A.33
408033	GMCNR	A.25
408035	GMCN	A.23
408036	GCNTW	A.27
408039	GLHDR	A.27
408040	GPBD	A.23
408041	GREPM	A.27
408042	GRHDR	A.27
408043	GRHN	A.33
408046	GTUS	A.26
408047	GUNI	A.33
408052	GSDFTR1	A.33
408054	GSDWTR	A.33
408057	GJP	A.27
408058	G16H4RVI	A.7
408059	G20H4RVI	A.7
408060	G16H4FFI	A.7
408061	G20H4FFI	A.7
408062	G16H6FFI	A.7
408063	G20H6FFI	A.7
408066	G32M4FFI	A.7
408067	G40M4FFI	A.7
408068	G32M6FFI	A.7
408069	G40M6FFI	A.7
408070	G32M4RVI	A.7
408071	G32M6RVI	A.7
408072	G40M4RVI	A.7
408073	G64L4RVI	A.7
408074	G40M6RVI	A.7
408075	G64L6RVI	A.7
408082	G16H6RVI	A.7
408083	G20H6RVI	A.7
408085	GFMTG	A.26
408097	G13HCLS	A.33
408098	G20HARC	A.33
408100	G16HCLS	A.33
408102	G20HCHT	A.33
408103	G20HCLS	A.33
408104	G20NARC	A.33
408106	G20MCLS	A.33
408109	G25MCLS	A.33
408117	G32MCLS	A.33
408120	G40MCLS	A.33
408131	G40MCHT	A.33
408144	G64LCHT	A.33
408145	G50LCLS	A.33
408148	G64LCLS	A.33
408162	G25MNR	A.28
408169	G40MARC	A.33
408172	G40NARC	A.33
408186	G32LNRC	A.28
408187	G40LNRC	A.28
408188	G50LNRC	A.28
408189	G64LNRC	A.28
408193	G64LARC	A.33
408200	GG16H2FXXXXM	A.15

Ref. No.	Cat. No.	Page
408202	GG16H2UXXXXM	A.14
408203	GG20H5FXXXXM	A.15
408205	GG16H5UXXXXM	A.14
408210	GG20H2FXXXXM	A.15
408212	GG20H2UXXXXM	A.14
408215	GG20H5UXXXXM	A.14
408222	GG20M2FXXXXM	A.15
408224	GG20M2UXXXXM	A.14
408225	GG20M5FXXXXM	A.15
408227	GG20M5UXXXXM	A.14
408234	GG25M2FXXXXM	A.15
408236	GG25M2UXXXXM	A.14
408237	GG25M5FXXXXM	A.15
408239	GG25M5UXXXXM	A.14
408245	GG32M2FXXXXM	A.15
408247	GG32M2UXXXXM	A.14
408249	GG32M5FXXXXM	A.15
408251	GG32M5UXXXXM	A.14
408254	GH32M2VXXXXR	A.29
408255	GH32M5VXXXXR	A.29
408257	GG40M2FXXXXM	A.15
408259	GG40M2UXXXXM	A.14
408261	GG40M5FXXXXM	A.15
408263	GG40M5UXXXXM	A.14
408267	GH40M2VXXXXR	A.29
408268	GH40M5VXXXXR	A.29
408281	GG64L2UXXXXM	A.14
408283	GG64L5UXXXXM	A.14
408292	GH32M2VXXXXM	A.14
408293	GH32M5VXXXXM	A.14
408294	GH40M2VXXXXM	A.14
408295	GH40M5VXXXXM	A.14
408300	G04HNCT	A.28
408301	G07HNCT	A.28
408302	G08HNCT	A.28
408303	G10HNCT	A.28
408304	G13HNCT	A.28
408305	G16HNCT	A.28
408306	G20HNCT	A.28
408322	G25MNCT	A.28
408331	G32LNCT	A.28
408332	G40LNCT	A.28
408333	G50LNCT	A.28
408334	G64LNCT	A.28
408350	GW04M4	A.6
408351	GW04M6	A.6
408352	GW07M4	A.6
408353	GW07M6	A.6
408354	GW08M4	A.6
408355	GW08M6	A.6
408356	GW10M4	A.6
408357	GW10M6	A.6
408358	GW13M4	A.6
408359	GW13M6	A.6
408360	GW16M4	A.6
408361	GW16M6	A.6
408362	GW20M4	A.6
408363	GW20M6	A.6
408364	GW25M4	A.6
408365	GW25M6	A.6
408366	GW32M4	A.6
408367	GW32M6	A.6
408368	GW40M4	A.6
408369	GW40M6	A.6
408370	GG04E2	A.9
408371	GG04E5	A.4
408372	GG04H2	A.9
408373	GG04H5	A.4
408374	GG04M2	A.10
408375	GG04M5	A.5
408376	GG04N2	A.9
408377	GG04N5	A.4
408378	GG04S2	A.9
408379	GG04S5	A.4
408390	GG07E2	A.9
408391	GG07E5	A.4
408392	GG07	

## By reference number

Ref. No.	Cat. No.	Page	Ref. No.	Cat. No.	Page	Ref. No.	Cat. No.	Page	Ref. No.	Cat. No.	Page
408405	GW08M3	A.12	408581	GG50L5	A.5	408801	GTG00K2XXSFXXXX	A.16	410661	GW25F4	A.6
408406	GW10M1	A.12	408582	GG50M2	A.10	408802	GTG00K2XXSRXXXX	A.31	410662	GJ25S6	A.6
408407	GW10M3	A.12	408583	GG50M5	A.5	408803	GTG00K9XXSFXXXX	A.16	410663	GW25F6	A.6
408408	GW13M1	A.12	408584	GG64L2	A.10	408805	GTG00K3XXSFXXXX	A.16	410664	GG25S1	A.9
408409	GW13M3	A.12	408585	GG64L5	A.5	408806	GTG00K4XXSFXXXX	A.16	410665	GG25S2	A.9
408410	GW16M1	A.12	408586	GG64M2	A.10	408807	GTG00K3X2SFXXXX	A.16	410666	GG25S3	A.9
408411	GW16M3	A.12	408587	GG64M5	A.5	408808	GTG00K4X2SFXXXX	A.16	410667	GG25F1	A.9
408412	GW20M1	A.12	408610	GJ04S2	A.12	408809	GTG00K4XX2XXXXSR	A.17	410668	GG25F2	A.9
408413	GW20M3	A.12	408611	GW04N2	A.12	408813	GTG00K9X4SFXXXX	A.31	410669	GG25F3	A.9
408414	GW25M1	A.12	408612	GJ04S5	A.6	408815	GTG00K3X4SFXXXX	A.17	410670	GW25F1	A.12
408415	GW25M3	A.12	408613	GW04N5	A.6	408816	GTG00K4X4SFXXXX	A.17	410671	GW25F3	A.12
408416	GW32M1	A.12	408614	GJ07S2	A.12	408817	GTG00K3T6SF	A.17	410672	GJ25S3	A.12
408417	GW32M3	A.12	408615	GW07N2	A.12	408818	GTG00K4T6SFXXXX	A.17	410673	GJ25S4	A.6
408418	GW40M1	A.12	408616	GJ07S5	A.6	408819	GTG00K4T6XXXXSR	A.31	410674	GJ25S1	A.12
408419	GW40M3	A.12	408617	GW07N5	A.6	408823	GTG00N9X5SFXXXX	A.18	410675	GG25F2VXXXXM	A.14
408430	GG08E2	A.9	408618	GJ08S2	A.12	408825	GTG00N5X5SFXXXX	A.18	410677	GG25H2UXXXXM	A.14
408431	GG08E5	A.4	408619	GW08N2	A.12	408826	GTG00N6X5SFXXXX	A.20	410678	GG25H5UXXXXM	A.14
408432	GG08H2	A.9	408620	GJ08S5	A.6	408827	GTG00N7X5SFXXXX	A.19	410679	GG25H2FXXXXM	A.15
408433	GG08H5	A.4	408621	GW08N5	A.6	408828	GTG00N8X5SFXXXX	A.20	410680	GG25H5FXXXXM	A.15
408434	GG08M2	A.10	408625	GJ10S2	A.12	408829	GTG00N5T5SFXXXX	A.18	410681	GG25H2UXXXXR	A.29
408435	GG08M5	A.5	408626	GW10N2	A.12	408830	GTG00N6T5SFXXXX	A.20	410682	GG25H5UXXXXR	A.29
408436	GG08N2	A.9	408627	GJ10S5	A.6	408831	GTG00N7T5SFXXXX	A.19	410683	GG25H2FXXXXR	A.29
408437	GG08N5	A.4	408628	GW10N5	A.6	408832	GTG00N8T5SFXXXX	A.20	410684	GG25H5FXXXXR	A.29
408438	GG08S2	A.9	408629	GJ13S2	A.12	408833	GTG00N5X8SFXXXX	A.18	410685	GG25F2VXXXXR	A.29
408439	GG08S5	A.4	408630	GW13N2	A.12	408834	GTG00N6X8SFXXXX	A.20	410686	GG25F5VXXXXR	A.29
408440	GG10E2	A.9	408635	GJ13S5	A.6	408835	GTG00N7X8SFXXXX	A.19	410689	GW25F2	A.12
408441	GG10E5	A.4	408636	GW13N5	A.6	408836	GTG00N8X8SFXXXX	A.20	410690	GW25F5	A.6
408442	GG10H2	A.9	408637	GJ16S2	A.12	408837	GTG00N5T8SFXXXX	A.18	410699	G16H1UNIR	A.14
408443	GG10H5	A.4	408638	GW16N2	A.12	408838	GTG00N6T8SFXXXX	A.20	410701	G32M1UNIR	A.14
408444	GG10M2	A.10	408639	GJ16S5	A.6	408839	GTG00N7T8SFXXXX	A.19	410702	GM01RVIR	A.14
408445	GG10M5	A.5	408640	GW16N5	A.6	408840	GTG00N8T8SFXXXX	A.20	410704	G64L1UNIR	A.14
408446	GG10N2	A.9	408641	GJ20S2	A.12	408841	GTG00N5X9SFXXXX	A.18	410705	GT16H3UNIR	A.14
408447	GG10N5	A.4	408642	GW20N2	A.12	408842	GTG00N6X9SFXXXX	A.20	410706	GT16H7UNIR	A.14
408448	GG10S2	A.9	408643	GJ20S5	A.6	408843	GTG00N7X9SFXXXX	A.19	444000		
408449	GG10S5	A.4	408644	GW20N5	A.6	408844	GTG00N8X9SFXXXX	A.20	444247	GMT0048A	A.22
408450	GG13E2	A.9	408651	GW07M5	A.6	408845	GTG00N5T9SFXXXX	A.18	444248	GMT0060D	A.22
408451	GG13E5	A.4	408653	GW08M2	A.12	408846	GTG00N6T9SFXXXX	A.20	444249	GMT0110D	A.22
408452	GG13H2	A.9	408655	GW08M5	A.6	408847	GTG00N7T9SFXXXX	A.19	444250	GMT0120A	A.22
408453	GG13H5	A.4	408657	GW10M2	A.12	408848	GTG00N8T9SFXXXX	A.20	444251	GMT0220D	A.22
408454	GG13M2	A.10	408659	GW10M5	A.6	408849	GTG00N5T8XXXXSR	A.32	444252	GMT0250D	A.22
408455	GG13M5	A.5	408666	GW13M2	A.12	408850	GTG00N6T8XXXXSR	A.32	444253	GT16N2SSL	A.33
408456	GG13N2	A.9	408668	GW13M5	A.6	408851	GTG00N7T8XXXXSR	A.32	444254	GT16N5SSL	A.33
408457	GG13N5	A.4	408670	GW16M2	A.12	408852	GTG00N8T8XXXXSR	A.32	444255	GTJP	A.27
408458	GG13S2	A.9	408672	GW16M5	A.6	408853	GTG00N5T9XXXXSR	A.32	444256	GLTHDR	A.27
408459	GG13S5	A.4	408674	GW20M2	A.12	408854	GTG00N6T9XXXXSR	A.32	444257	GTRHDR	A.27
408490	GG16E2	A.9	408676	GW20M5	A.6	408855	GTG00N7T9XXXXSR	A.32	444258	GTSDFTF	A.33
408491	GG16E5	A.4	408680	GJ25N2	A.12	408856	GTG00N8T9XXXXSR	A.32	444259	GTSDWTR	A.33
408492	GG16H2	A.9	408682	GW25M2	A.12	408860	GTUNI	A.16	444500	GT04R1	A.9
408493	GG16H5	A.4	408683	GJ25N5	A.6	408863	GTG00N9X8SFXXXX	A.18	444501	GT07R1	A.9
408494	GG16M2	A.10	408685	GW25M5	A.6	408865	GTG00N9X9SFXXXX	A.18	444502	GT08R1	A.9
408495	GG16M5	A.5	408686	GJ32N2	A.12	410000			444503	GT10R1	A.9
408496	GG16N2	A.9	408688	GW32M2	A.12	410609	GRON	A.25	444504	GT13R1	A.9
408497	GG16N5	A.4	408689	GJ32N5	A.6	410623	GG16H2XXXXXM	A.15	444505	GT16R1	A.9
408498	GG16S2	A.9	408691	GW32M5	A.6	410624	GG16H2XXXXR	A.29	444506	GT04K1	A.9
408499	GG16S5	A.4	408692	GJ40N2	A.12	410625	GG16H5XXXXXM	A.15	444507	GT07K1	A.9
408510	GG20E2	A.9	408694	GW40M2	A.12	410626	GG16H5XXXXR	A.29	444508	GT08K1	A.9
408511	GG20E5	A.4	408695	GW40M5	A.6	410627	GG16S2XXXXXM	A.15	444509	GT10K1	A.9
408512	GG20H2	A.9	408697	GW40M5	A.6	410629	GG16S5XXXXXM	A.15	444510	GT13K1	A.9
408513	GG20H5	A.4	408710	GW04M2	A.12	410630	GT16K5XXXXR	A.29	444511	GT16K1	A.9
408514	GG20M2	A.10	408712	GW04M5	A.6	410631	GG20H2XXXXXM	A.15	444512	GT16K2XXXXXM	A.15
408515	GG20M5	A.5	408714	GW07M2	A.12	410632	GG20H2XXXXR	A.29	444513	GT16K2XXXXR	A.29
408516	GG20N2	A.9	408720	GJ32L2	A.12	410633	GG20H5XXXXXM	A.15	444514	GT16K5XXXXXM	A.15
408517	GG20N5	A.4	408721	GJ32L5	A.6	410634	GG20H5XXXXR	A.29	444515	GT16K5XXXXR	A.29
408518	GG20S2	A.9	408722	GJ40L2	A.12	410635	GG20M2XXXXXM	A.15	444520	GT04R3	A.9
408519	GG20S5	A.4	408723	GJ40L5	A.6	410636	GG20M2XXXXR	A.29	444521	GT07R3	A.9
408526	GG25H5	A.4	408724	GJ50L2	A.12	410637	GG20M5XXXXXM	A.15	444522	GT08R3	A.9
408527	GG25M2	A.10	408725	GJ50L5	A.6	410638	GG20M5XXXXR	A.29	444523	GT10R3	A.9
408528	GG25M5	A.5	408726	GJ64L2	A.12	410639	GG25M2XXXXXM	A.15	444524	GT13R3	A.9
408529	GG25N2	A.9	408727	GJ64L5	A.6	410640	GG25M2XXXXR	A.29	444525	GT16R3	A.9
408530	GG25N5	A.4	408750	GTG00NDT5SFXXXX	A.21	410641	GG25M5XXXXXM	A.15	444526	GT04K3	A.9
408540	GG32G2	A.10	408751	GTG00NDT8SFXXXX	A.21	410642	GG25M5XXXXR	A.29	444527	GT07K3	A.9
408541	GG32G5	A.5	408753	GTG00NDT9SFXXXX	A.21	410643	GG32M2XXXXXM	A.15	444528	GT08K3	A.9
408543	GG32H5	A.4	408755	GTG00NDX5SFXXXX	A.21	410644	GG32M2XXXXR	A.29	444529	GT10K3	A.9
408544	GG32L2	A.10	408756	GTG00NDX8SFXXXX	A.21	410645	GG32M5XXXXXM	A.15	444530	GT13K3	A.9
408545	GG32L5	A.5	408757	GTG00NDX9SFXXXX	A.21	410646	GG32M5XXXXR	A.29	444531	GT16K3	A.9
408546	GG32M2	A.10	408758	GTG00NFT5SFXXXX	A.21	410647	GG40M2XXXXXM	A.15	444542	GT04R4	A.4
408547	GG32M5	A.5	408759	GTG00NFT8SFXXXX	A.21	410648	GG40M5XXXXXM	A.15	444543	GT07R4	A.4
408548	GG32N2	A.9	408761	GTG00NFT9SFXXXX	A.21	410649	GG40M2XXXXR	A.29	444544	GT08R4	A.4
408549	GG32N5	A.4	408763	GTG00NFX5SFXXXX	A.21	410650	GG40M5XXXXR	A.29	444545	GT10R4	A.4
408560	GG40G2	A.10	408764	GTG00NFX8SFXXXX	A.21	410651	GG64L2XXXXXM	A.15	444546	GT13R4	A.4
408561	GG40G5	A.5	408765	GTG00NFX9SFXXXX	A.21	410652	GG64L2XXXXR	A.29	444547	GT16R4	A.4
408563	GG40H5	A.4	408780	GTURSK	A.26	410653	GG64L5XXXXXM	A.15	444548	GT04K4	A.4
408564	GG40L2	A.10	408789	GAPU	A.26	410654	GG64L5XXXXR	A.29	444549	GT07K4	A.4
408565	GG40L5	A.5	408790	GMPU1	A.26	410655	GG25S4	A.4	444550	GT08K4	A.4
408566	GG40M2	A.10	408791	GMPU2	A.26	410656	GG25S5	A.4	444551	GT10K4	A.4
408567	GG40M5	A.5	408792	GMPU3	A.26	410657	GG25S6	A.4	444552	GT13K4	A.4
408568	GG40N2	A.9	408793	GMPU4	A.26	410658	GG25F4	A.4	444553	GT16K4	A.4
408569	GG40N5	A.4	408796	G3G00KAXXXXXSR	A.32	410659	GG25F5	A.4	444563	GT04R6	A.4
408580	GG50L2	A.10	408800	GTG00K1XXSFXXXX	A.16	410660	GG25F6	A.4	444564	GT07R6	A.4



By reference number

Ref. No.	Cat. No.	Page
444565	GT08R6	A.4
444566	GT10R6	A.4
444567	GT13R6	A.4
444568	GT16R6	A.4
444569	GT04K6	A.4
444570	GT07K6	A.4
444571	GT08K6	A.4
444572	GT10K6	A.4
444573	GT13K6	A.4
444574	GT16K6	A.4
444585	G704R1	A.12
444586	G707R1	A.12
444587	G708R1	A.12
444588	G710R1	A.12
444589	G713R1	A.12
444590	G716R1	A.12
444600	G704R3	A.12
444601	G707R3	A.12
444602	G708R3	A.12
444603	G710R3	A.12
444604	G713R3	A.12
444605	G716R3	A.12
444616	G704R4	A.6
444617	G707R4	A.6
444618	G708R4	A.6
444619	G710R4	A.6
444620	G713R4	A.6
444621	G716R4	A.6
444625	GT16H4FFI	A.7
444626	GT16H4RVI	A.7
444627	GT16H6FFI	A.7
444628	GT16H6RVI	A.7
444630	GMT0024D	A.22
444631	GMT0048D	A.22
444632	G704R6	A.6
444633	G707R6	A.6
444634	G708R6	A.6
444635	G710R6	A.6
444636	G713R6	A.6
444637	G716R6	A.6
444638	GMT0240A	A.22
444639	GMT0400A	A.22
444640	GMT0440A	A.22
444641	GMT0024DR	A.24
444642	GMT0048DR	A.24
444643	GMT0060DR	A.24
444644	GMT0110DR	A.24
444645	GMT0220DR	A.24
444646	GMT0250DR	A.24
444647	GMT0048AR	A.24
444648	GMT0120AR	A.24
444649	GMT0240AR	A.24
444650	GMT0400AR	A.24
444651	GMT0440AR	A.24
444655	GTAS3	A.22
444656	GTAS4	A.22
444658	GTAS3R	A.24
444659	GTAS4R	A.24
444660	GTBAT1	A.22
444661	GTBATS1	A.22
444665	GTBPRO	A.23
444666	GTBRON	A.23
444667	GTBPD	A.27
444668	GTCPRO	A.23
444669	GTCRON	A.23
444672	GTBAT1R	A.24
444673	GTBATS1R	A.24
444674	GTREPM	A.27
444675	GT12FAD	A.23
444676	GT12WAD	A.23
444677	GT13FB	A.23
444678	GT13WB	A.23
444679	GT13FC	A.23
444680	GT13WC	A.23
444681	GT13FDT	A.23
444682	GT13WDT	A.23
444683	GBTRONR	A.25
444690	GT16K2FXXXXM	A.15
444691	GT16K2UXXXXM	A.14
444692	GT16K2HXXXM	A.14
444693	GT16K5FXXXXM	A.15
444694	GT16K5UXXXXM	A.14
444695	GT16K5HXXXM	A.14
444700	GT16K2FXXXXR	A.29
444701	GT16K2UXXXXR	A.29
444702	GT16K2HXXXR	A.29
444703	GT16K5FXXXXR	A.29
444704	GT16K5UXXXXR	A.29
444705	GT16K5HXXXR	A.29

By catalogue number

Ref. No.	Cat. No.	Page
444710	GTHDTUF	A.33
444711	GTHDTUD	A.33
444726	GT04K2	A.9
444727	GT07K2	A.9
444728	GT08K2	A.9
444729	GT10K2	A.9
444730	GT13K2	A.9
444731	GT16K2	A.9
444740	GT04R5	A.4
444741	GT07R5	A.4
444742	GT08R5	A.4
444743	GT10R5	A.4
444744	GT13R5	A.4
444745	GT16R5	A.4
444746	GT04K5	A.4
444747	GT07K5	A.4
444748	GT08K5	A.4
444749	GT10K5	A.4
444750	GT13K5	A.4
444751	GT16K5	A.4
444752	GT04R2	A.12
444761	G707R2	A.12
444762	G708R2	A.12
444763	G710R2	A.12
444764	G713R2	A.12
444765	G716R2	A.12
444775	G704R5	A.6
444776	G707R5	A.6
444777	G708R5	A.6
444778	G710R5	A.6
444779	G713R5	A.6
444780	G716R5	A.6
444790	GTCPS1	A.22
444791	GTCPS1R	A.24
444792	GTCPS2	A.22
444793	GTCPS2R	A.24
444794	GTCPSA	A.22
444795	GTCPSAR	A.24
444800	GT16KCLS	A.33
444801	GT16KCHT	A.33
444802	GT16KARC	A.33
444803	GTRHN	A.33
444804	GTFAL	A.33
444805	GTDPRF	A.27
444806	GTPRW	A.27

Cat. No.	Ref. No.	Page
G...		
G04HNCT	408300	A.28
G04HNRC	408000	A.28
G07HNCT	408301	A.28
G07HNRC	408001	A.28
G08HNCT	408302	A.28
G08HNRC	408002	A.28
G10HNCT	408303	A.28
G10HNRC	408003	A.28
G13HCLS	408097	A.33
G13HNCT	408304	A.28
G13HNRC	408004	A.28
G16H1UNIR	410699	A.14
G16H4ED	407930	A.26
G16H4FFI	408060	A.7
G16H4RVI	408058	A.7
G16H6ED	407931	A.26
G16H6FFI	408062	A.7
G16H6RVI	408082	A.7
G16HCLS	408100	A.33
G16HNCT	408305	A.28
G16HNRC	408005	A.28
G20H2SSL	407606	A.33
G20H4ED	407932	A.26
G20H4FFI	408061	A.7
G20H4RVI	408059	A.7
G20H5SSL	407607	A.33
G20H6ED	407933	A.26
G20H6FFI	408063	A.7
G20H6RVI	408083	A.7
G20HARC	408098	A.33
G20HCHT	408102	A.33
G20HCLS	408103	A.33
G20HNCT	408306	A.28
G20HNRC	408006	A.28
G20MCLS	408106	A.33
G20NARC	408104	A.33
G25HNRC		A.28
G25MCLS	408109	A.33
G25MNCT	408322	A.28
G25MNRC	408162	A.28
G32LNCT	408331	A.28
G32LNRC	408186	A.28
G32M1UNIR	410701	A.14
G32M4FFI	408066	A.7
G32M4RVI	408070	A.7
G32M6FFI	408068	A.7
G32M6RVI	408071	A.7
G32MCLS	408117	A.33
G300KAXXXXXSR	408796	A.33
G40LNCT	408332	A.28
G40LNRC	408187	A.28
G40M1RVIR	410702	A.14
G40M2SSL	407636	A.33
G40M4ED	407934	A.26
G40M4FFI	408067	A.7
G40M4RVI	408072	A.7
G40M5SSL	407637	A.33
G40M6ED	407935	A.26
G40M6FFI	408069	A.7
G40M6RVI	408074	A.7
G40MARC	408169	A.33
G40MCHT	408131	A.33
G40MCLS	408120	A.33
G40NARC	408172	A.33
G50LCLS	408145	A.33
G50LNCT	408333	A.28
G50LNRC	408188	A.28
G64L1UNIR	410704	A.14
G64L2SSL	407679	A.33
G64L4RVI	408073	A.7
G64L5SSL	407680	A.33
G64L6RVI	408075	A.7
G64LARC	408193	A.33
G64LCHT	408144	A.33
G64LCLS	408148	A.33
G64LNCT	408334	A.28
G64LNRC	408189	A.28
G64M4ED	407936	A.26
G64M6ED	407937	A.26
G704R1	444585	A.12
G704R2	444760	A.12
G704R3	444600	A.12
G704R4	444616	A.6
G704R5	444775	A.6
G704R6	444632	A.6
G707R1	444586	A.12
G707R2	444761	A.12
G707R3	444601	A.12

Cat. No.	Ref. No.	Page
G707R4	444617	A.6
G707R5	444776	A.6
G707R6	444633	A.6
G708R1	444587	A.12
G708R2	444762	A.12
G708R3	444602	A.12
G708R4	444618	A.6
G708R5	444777	A.6
G708R6	444634	A.6
G710R1	444588	A.12
G710R2	444763	A.12
G710R3	444603	A.12
G710R4	444619	A.6
G710R5	444778	A.6
G710R6	444635	A.6
G713R1	444589	A.12
G713R2	444764	A.12
G713R3	444604	A.12
G713R4	444620	A.6
G713R5	444779	A.6
G713R6	444636	A.6
G716R1	444590	A.12
G716R2	444765	A.12
G716R3	444605	A.12
G716R4	444621	A.6
G716R5	444780	A.6
G716R6	444637	A.6
GA...		
GAPU	408789	A.26
GAS3	407885	A.22
GAS3R	407880	A.24
GAS5	407886	A.22
GAS5R	407881	A.24
GAS6	407887	A.22
GAS6R	407882	A.24
GAS8	407888	A.22
GAS8R	407883	A.24
GB...		
GBAT1	407891	A.22
GBAT1R	407889	A.24
GBAT51	407890	A.22
GBCAS	407970	A.23
GBCASR	407967	A.25
GBPRO	407978	A.23
GBPROR	407979	A.25
GBRON	407971	A.23
GBRONR	407968	A.25
GBTRONR	444683	A.25
GC...		
GCAS	407986	A.25
GCB1	407990	A.26
GCB2	407991	A.26
GCB3	407992	A.26
GCB4	407993	A.26
GCB5	407994	A.26
GCB6	407995	A.26
GCB7	407996	A.26
GCCC024D	407836	A.22
GCCC024DR	407835	A.24
GCCC048	407838	A.22
GCCC048R	407837	A.24
GCCC060D	407840	A.22
GCCC060DR	407839	A.24
GCCC120	407842	A.22
GCCC120R	407841	A.24
GCCC240	407844	A.22
GCCC240R	407843	A.24
GCCC277	407849	A.22
GCCC277R	407850	A.24
GCCC400A	407852	A.22
GCCC400AR	407851	A.24
GCCC440A	407853	A.22
GCCC440AR	407854	A.24
GCCN024D	407861	A.22
GCCN024DR	407860	A.24
GCCN048	407863	A.22
GCCN048R	407862	A.24
GCCN060D	407865	A.22
GCCN060DR	407864	A.24
GCCN120	407867	A.22
GCCN120R	407866	A.24
GCCN240	407869	A.22
GCCN240R	407868	A.24
GCCN277	407870	A.22
GCCN277R	407871	A.24
GCCN400A	407877	A.22
GCCN400AR	407876	A.24
GCCN440A	407878	A.22
GCCN440AR	407879	A.24

By catalogue number

Intro

A

B

C

D

E

F

X



## By catalogue number

Cat. No.	Ref. No.	Page
GCNTW	408036	A.27
GCPRO	407980	A.23
GCPORR	407981	A.25
GCP51	407922	A.22
GCP51R	407924	A.24
GCP52	407923	A.22
GCP52R	407925	A.24
GCP55R	407088	A.24
GCP5A	407055	A.22
GCP5AR	407056	A.24
GCRON	407976	A.23
GCRONR	407974	A.25
GCSPI	407895	A.22
GCSPIR	407915	A.24
GCSPI2	407896	A.22
GCSPI2R	407916	A.24
GCSST024D		A.22
GCSST030D		A.22
GCSST048		A.22
GCSST060D		A.22
GCSST120		A.22
GCSST240		A.22
GCSST277		A.22
GCSST400A		A.22
GCSST440A		A.22
<b>GD...</b>		
GDPRF	408025	A.27
GDPRW	408026	A.27
<b>GE...</b>		
GE-1000		A.27
<b>GF...</b>		
GFA4	408028	A.33
GFMTG	408085	A.26
<b>GJ...</b>		
GJ25N5	408683	A.6
GJ32N5	408689	A.6
GJ40N5	408695	A.6
<b>GG...</b>		
GG04E1	407001	A.9
GG04E2	408370	A.9
GG04E3	407002	A.9
GG04E4	407003	A.4
GG04E5	408371	A.4
GG04E6	407004	A.4
GG04H1	407005	A.9
GG04H2	408372	A.9
GG04H3	407006	A.9
GG04H4	407007	A.4
GG04H5	408373	A.4
GG04H6	407008	A.4
GG04M1	407009	A.10
GG04M2	408374	A.10
GG04M3	407010	A.10
GG04M4	407011	A.5
GG04M5	408375	A.5
GG04M6	407012	A.5
GG04N1	407013	A.9
GG04N2	408376	A.9
GG04N3	407014	A.9
GG04N4	407015	A.4
GG04N5	408377	A.4
GG04N6	407016	A.4
GG04S1	407017	A.9
GG04S2	408378	A.9
GG04S3	407018	A.9
GG04S4	407019	A.4
GG04S5	408379	A.4
GG04S6	407020	A.4
GG07E1	407030	A.9
GG07E2	408390	A.9
GG07E3	407031	A.9
GG07E4	407032	A.4
GG07E5	408391	A.4
GG07E6	407033	A.4
GG07H1	407034	A.9
GG07H2	408392	A.9
GG07H3	407035	A.9
GG07H4	407036	A.4
GG07H5	408393	A.4
GG07H6	407037	A.4
GG07M1	407038	A.10
GG07M2	408394	A.10
GG07M3	407039	A.10
GG07M4	407040	A.5
GG07M5	408395	A.5
GG07M6	407041	A.5
GG07N1	407042	A.9
GG07N2	408396	A.9
GG07N3	407043	A.9

Cat. No.	Ref. No.	Page
GG07N4	407044	A.4
GG07N5	408397	A.4
GG07N6	407045	A.4
GG07S1	407046	A.9
GG07S2	408398	A.9
GG07S3	407047	A.9
GG07S4	407048	A.4
GG07S5	408399	A.4
GG07S6	407049	A.4
GG08E1	407060	A.9
GG08E2	408430	A.9
GG08E3	407061	A.9
GG08E4	407062	A.4
GG08E5	408431	A.4
GG08E6	407063	A.4
GG08H1	407064	A.9
GG08H2	408432	A.9
GG08H3	407065	A.9
GG08H4	407066	A.4
GG08H5	408433	A.4
GG08H6	407067	A.4
GG08M1	407068	A.10
GG08M2	408434	A.10
GG08M3	407069	A.10
GG08M4	407070	A.5
GG08M5	408435	A.5
GG08M6	407071	A.5
GG08N1	407072	A.9
GG08N2	408436	A.9
GG08N3	407073	A.9
GG08N4	407074	A.4
GG08N5	408437	A.4
GG08N6	407075	A.4
GG08S1	407076	A.9
GG08S2	408438	A.9
GG08S3	407077	A.9
GG08S4	407078	A.4
GG08S5	408439	A.4
GG08S6	407079	A.4
GG10E1	407090	A.9
GG10E2	408440	A.9
GG10E3	407091	A.9
GG10E4	407092	A.4
GG10E5	408441	A.4
GG10E6	407093	A.4
GG10H1	407094	A.9
GG10H2	408442	A.9
GG10H3	407095	A.9
GG10H4	407096	A.4
GG10H5	408443	A.4
GG10H6	407097	A.4
GG10M1	407098	A.10
GG10M2	408444	A.10
GG10M3	407099	A.10
GG10M4	407100	A.5
GG10M5	408445	A.5
GG10M6	407101	A.5
GG10N1	407102	A.9
GG10N2	408446	A.9
GG10N3	407103	A.9
GG10N4	407104	A.4
GG10N5	408447	A.4
GG10N6	407105	A.4
GG10S1	407106	A.9
GG10S2	408448	A.9
GG10S3	407107	A.9
GG10S4	407108	A.4
GG10S5	408449	A.4
GG10S6	407109	A.4
GG13E1	407120	A.9
GG13E2	408450	A.9
GG13E3	407121	A.9
GG13E4	407122	A.4
GG13E5	408451	A.4
GG13E6	407123	A.4
GG13H1	407124	A.9
GG13H2	408452	A.9
GG13H3	407125	A.9
GG13H4	407126	A.4
GG13H5	408453	A.4
GG13H6	407127	A.4
GG13M1	407128	A.10
GG13M2	408454	A.10
GG13M3	407129	A.10
GG13M4	407130	A.5
GG13M5	408455	A.5
GG13M6	407131	A.5
GG13N1	407132	A.9
GG13N2	408456	A.9

Cat. No.	Ref. No.	Page
GG13N3	407133	A.9
GG13N4	407134	A.4
GG13N5	408457	A.4
GG13N6	407135	A.4
GG13S1	407136	A.9
GG13S2	408458	A.9
GG13S3	407137	A.9
GG13S4	407138	A.4
GG13S5	408459	A.4
GG13S6	407139	A.4
GG16E1	407150	A.9
GG16E2	408490	A.9
GG16E3	407151	A.9
GG16E4	407152	A.4
GG16E5	408491	A.4
GG16E6	407153	A.4
GG16H1	407154	A.9
GG16H2	408492	A.9
GG16H2FXXXXM	408200	A.15
GG16H2FXXXXR	407610	A.29
GG16H2UXXXXM	408202	A.14
GG16H2UXXXXR	407612	A.29
GG16H2XR	410624	A.29
GG16H2XXXXM	410623	A.15
GG16H3	407155	A.9
GG16H4	407156	A.4
GG16H5	408493	A.4
GG16H5FXXXXM	408203	A.15
GG16H5FXXXXR	407613	A.29
GG16H5UXXXXM	408205	A.14
GG16H5UXXXXR	407615	A.29
GG16H5XR	410626	A.29
GG16H5XXXXM	410625	A.15
GG16H6	407157	A.4
GG16M1	407158	A.10
GG16M2	408494	A.10
GG16M3	407159	A.10
GG16M4	407160	A.5
GG16M5	408495	A.5
GG16M6	407161	A.5
GG16N1	407162	A.9
GG16N2	408496	A.9
GG16N3	407163	A.9
GG16N4	407164	A.4
GG16N5	408497	A.4
GG16N6	407165	A.4
GG16S1	407166	A.9
GG16S2	408498	A.9
GG16S2FXXXXM	407626	A.15
GG16S2FXXXXR	407627	A.29
GG16S2UXXXXM	407616	A.14
GG16S2UXXXXR	407617	A.29
GG16S2XXXXM	410627	A.15
GG16S3	407167	A.9
GG16S4	407168	A.4
GG16S5	408499	A.4
GG16S5FXXXXM	407628	A.15
GG16S5FXXXXR	407629	A.29
GG16S5UXXXXM	407618	A.14
GG16S5UXXXXR	407619	A.29
GG16S5XXXXM	410630	A.29
GG16S5XXXXR	410629	A.15
GG16S6	407169	A.4
GG20E1	407190	A.9
GG20E2	408510	A.9
GG20E3	407191	A.9
GG20E4	407192	A.4
GG20E5	408511	A.4
GG20E6	407193	A.4
GG20H1	407194	A.9
GG20H2	408512	A.9
GG20H2FXXXXM	408210	A.15
GG20H2FXXXXR	407620	A.29
GG20H2UXXXXM	408212	A.14
GG20H2UXXXXR	407622	A.29
GG20H2XR	410632	A.29
GG20H2XXXXM	410631	A.15
GG20H3	407195	A.9
GG20H4	407196	A.4
GG20H5	408513	A.4
GG20H5FXXXXM	408213	A.15
GG20H5FXXXXR	407623	A.29
GG20H5UXXXXM	408215	A.14
GG20H5UXXXXR	407625	A.29
GG20H5XR	410634	A.29
GG20H5XXXXM	410633	A.15
GG20H6	407197	A.4
GG20M1	407198	A.10
GG20M2	408514	A.10

Cat. No.	Ref. No.	Page
GG20M2FXXXXM	408222	A.15
GG20M2FXXXXR	407630	A.29
GG20M2UXXXXM	408224	A.14
GG20M2UXXXXR	407632	A.29
GG20M2XR	410636	A.29
GG20M2XXXXM	410635	A.15
GG20M3	407199	A.10
GG20M4	407200	A.5
GG20M5	408515	A.5
GG20M5FXXXXM	408225	A.15
GG20M5FXXXXR	407633	A.29
GG20M5UXXXXM	408227	A.14
GG20M5UXXXXR	407635	A.29
GG20M5XR	410638	A.29
GG20M5XXXXM	410637	A.15
GG20M6	407201	A.5
GG20N1	407202	A.9
GG20N2	408516	A.9
GG20N3	407203	A.9
GG20N4	407204	A.4
GG20N5	408517	A.4
GG20N6	407205	A.4
GG20S1	407206	A.9
GG20S2	408518	A.9
GG20S3	407207	A.9
GG20S4	407208	A.4
GG20S5	408519	A.4
GG20S6	407209	A.4
GG25F1	410667	A.9
GG25F2	410668	A.9
GG25F2VXXXXM	410675	A.14
GG25F2VXXXXR	410685	A.29
GG25F3	410669	A.9
GG25F4	410658	A.4
GG25F5	410659	A.4
GG25F5VXXXXM	407676	A.14
GG25F5VXXXXR	410686	A.29
GG25F6	410660	A.4
GG25H1	407230	A.9
GG25H2FXXXXM	410679	A.15
GG25H2FXXXXR	410683	A.29
GG25H2UXXXXM	410677	A.14
GG25H2UXXXXR	410681	A.9
GG25H3	407231	A.4
GG25H4	407232	A.4
GG25H5	408526	A.4
GG25H5FXXXXM	410680	A.15
GG25H5FXXXXR	410684	A.29
GG25H5UXXXXM	410678	A.14
GG25H5UXXXXR	410682	A.29
GG25H6	407233	A.4
GG25M1	407234	A.10
GG25M2	408527	A.10
GG25M2FXXXXM	408234	A.15
GG25M2FXXXXR	407640	A.29
GG25M2UXXXXM	408236	A.14
GG25M2UXXXXR	407642	A.29
GG25M2XR	410640	A.29
GG25M2XXXXM	410639	A.15
GG25M3	407235	A.10
GG25M4	407236	A.5
GG25M5	408528	A.5
GG25M5FXXXXM	408237	A.15
GG25M5FXXXXR	407643	A.29
GG25M5UXXXXM	408239	A.14
GG25M5UXXXXR	407645	A.29
GG25M5XR	410642	A.29
GG25M5XXXXM	410641	A.15
GG25M6	407237	A.5
GG25N1	407238	A.9
GG25N2	408529	A.9
GG25N3	407239	A.9
GG25N4	407240	A.4
GG25N5	408530	A.4
GG25N6	407241	A.4
GG25S1	410664	A.9
GG25S2	410665	A.9
GG25S3	410666	A.9
GG25S4	410655	A.4
GG25S5	410656	A.4
GG25S6	410657	A.4
GG32G1	407250	A.10
GG32G2	408540	A.10
GG32G3	407251	A.10
GG32G4	407252	A.5
GG32G5	408541	A.5
GG32G6	407253	A.5
GG32H1	407242	A.9
GG32H3	407273	A



Cat. No.	Ref. No.	Page
GG32H4	407244	A.4
GG32H5	408543	A.4
GG32H6	407245	A.4
GG32L1	407248	A.10
GG32L2	408544	A.10
GG32L3	407249	A.10
GG32L4	407254	A.5
GG32L5	408545	A.5
GG32L6	407255	A.5
GG32M1	407260	A.10
GG32M2	408546	A.10
GG32M2FXXXM	408245	A.15
GG32M2FXXXR	407650	A.29
GG32M2UXXXM	408247	A.14
GG32M2UXXXR	407652	A.29
GG32M2XR	410644	A.29
GG32M2XXXXM	410643	A.15
GG32M3	407261	A.10
GG32M4	407262	A.5
GG32M5	408547	A.5
GG32M5FXXXM	408249	A.15
GG32M5FXXXR	407654	A.29
GG32M5VXXM	408251	A.14
GG32M5VXXR	407656	A.29
GG32M5XR	410646	A.29
GG32M5VXXXM	410645	A.15
GG32M6	407263	A.5
GG32N1	407264	A.9
GG32N2	408548	A.9
GG32N3	407265	A.9
GG32N4	407266	A.4
GG32N5	408549	A.4
GG32N6	407267	A.4
GG40G1	407268	A.10
GG40G2	408560	A.10
GG40G3	407269	A.10
GG40G4	407270	A.5
GG40G5	408561	A.5
GG40G6	407271	A.5
GG40H1	407278	A.9
GG40H3	407279	A.9
GG40H4	407280	A.4
GG40H5	408563	A.4
GG40H6	407281	A.4
GG40L1	407282	A.10
GG40L2	408564	A.10
GG40L3	407283	A.10
GG40L4	407284	A.5
GG40L5	408565	A.5
GG40L6	407285	A.5
GG40M1	407286	A.10
GG40M2	408566	A.10
GG40M2FXXXM	408257	A.15
GG40M2FXXXR	407658	A.29
GG40M2UXXXM	408259	A.14
GG40M2UXXXR	407666	A.29
GG40M2XR	410649	A.29
GG40M2XXXXM	410647	A.15
GG40M3	407287	A.10
GG40M4	407288	A.5
GG40M5	408567	A.5
GG40M5FXXXM	408261	A.15
GG40M5FXXXR	407668	A.29
GG40M5VXXM	408263	A.14
GG40M5VXXR	407670	A.29
GG40M5XR	410650	A.29
GG40M5VXXXM	410648	A.15
GG40M6	407289	A.5
GG40N1	407290	A.9
GG40N2	408568	A.9
GG40N3	407291	A.9
GG40N4	407292	A.4
GG40N5	408569	A.4
GG40N6	407293	A.4
GG50L1	407300	A.10
GG50L2	408580	A.10
GG50L3	407301	A.10
GG50L4	407302	A.5
GG50L5	408581	A.5
GG50L6	407303	A.5
GG50M1	407304	A.10
GG50M2	408582	A.10
GG50M3	407305	A.10
GG50M4	407306	A.5
GG50M5	408583	A.5
GG50M6	407307	A.5
GG64L1	407320	A.10
GG64L2	408584	A.10
GG64L2UXXXM	408281	A.14

Cat. No.	Ref. No.	Page
GG64L2UXXXR	407686	A.29
GG64L2XR	410652	A.29
GG64L2XXXXM	410651	A.15
GG64L3	407321	A.10
GG64L4	407322	A.5
GG64L5	408585	A.5
GG64L5UXXXM	408283	A.14
GG64L5UXXXR	407688	A.29
GG64L5XR	410654	A.29
GG64L5XXXXM	410653	A.15
GG64L6	407323	A.5
GG64M1	407324	A.10
GG64M2	408586	A.10
GG64M3	407325	A.10
GG64M4	407326	A.5
GG64M5	408587	A.5
GG64M6	407327	A.5
GGDEFD	287030	A.27
<b>GH...</b>		
GH32H1	407346	A.11
GH32H3	407347	A.11
GH32M1	407348	A.11
GH32M2VXXM	408292	A.14
GH32M2VXXR	408254	A.29
GH32M3	407349	A.11
GH32M5VXXM	408293	A.14
GH32M5VXXR	408255	A.29
GH32N1	407350	A.11
GH32N3	407351	A.11
GH40H1	407352	A.11
GH40H3	407353	A.11
GH40M1	407354	A.11
GH40M2VXXM	408294	A.14
GH40M2VXXR	408267	A.29
GH40M3	407355	A.11
GH40M5VXXM	408295	A.14
GH40M5VXXR	408268	A.29
GH40N1	407356	A.11
GH40N3	407357	A.11
<b>GI...</b>		
GI2FAD	407900	A.23
GI2WAD	407901	A.23
GI3FB	407902	A.23
GI3FC	407904	A.23
GI3FDT	407906	A.23
GI3WB	407903	A.23
GI3WC	407905	A.23
GI3WDT	407907	A.23
<b>GJ...</b>		
GJ04S1	407378	A.12
GJ04S2	408610	A.12
GJ04S3	407379	A.12
GJ04S4	407380	A.6
GJ04S5	408612	A.6
GJ04S6	407381	A.6
GJ07S1	407398	A.12
GJ07S2	408614	A.12
GJ07S3	407399	A.12
GJ07S4	407400	A.6
GJ07S5	408616	A.6
GJ07S6	407401	A.6
GJ08S1	407418	A.12
GJ08S2	408618	A.12
GJ08S3	407419	A.12
GJ08S4	407420	A.6
GJ08S5	408620	A.6
GJ08S6	407421	A.6
GJ10S1	407438	A.12
GJ10S2	408625	A.12
GJ10S3	407439	A.12
GJ10S4	407440	A.6
GJ10S5	408627	A.6
GJ10S6	407441	A.6
GJ13S1	407458	A.12
GJ13S2	408629	A.12
GJ13S3	407459	A.12
GJ13S4	407460	A.6
GJ13S5	408635	A.6
GJ13S6	407461	A.6
GJ16S1	407478	A.12
GJ16S2	408637	A.12
GJ16S3	407479	A.12
GJ16S4	407480	A.6
GJ16S5	408639	A.6
GJ16S6	407481	A.6
GJ20S1	407498	A.12
GJ20S2	408641	A.12
GJ20S3	407499	A.12
GJ20S4	407500	A.6

Cat. No.	Ref. No.	Page
GJ20S5	408643	A.6
GJ20S6	407501	A.6
GJ25N1	407518	A.12
GJ25N2	408680	A.12
GJ25N3	407519	A.12
GJ25N4	407520	A.6
GJ25N6	407521	A.6
GJ25S1	410674	A.12
GJ25S3	410672	A.12
GJ25S4	410673	A.6
GJ25S6	410662	A.6
GJ32L1	407533	A.12
GJ32L2	408720	A.12
GJ32L3	407534	A.12
GJ32L4	407535	A.6
GJ32L5	408721	A.6
GJ32L6	407536	A.6
GJ32N1	407537	A.12
GJ32N2	408686	A.12
GJ32N3	407538	A.12
GJ32N4	407539	A.6
GJ32N6	407540	A.6
GJ40L1	407554	A.12
GJ40L2	408722	A.12
GJ40L3	407555	A.12
GJ40L4	407556	A.6
GJ40L5	408723	A.6
GJ40L6	407557	A.6
GJ40N1	407558	A.12
GJ40N2	408692	A.12
GJ40N3	407559	A.12
GJ40N4	407560	A.6
GJ40N6	407561	A.6
GJ50L1	407565	A.12
GJ50L2	408724	A.12
GJ50L3	407566	A.12
GJ50L4	407567	A.6
GJ50L5	408725	A.6
GJ50L6	407568	A.6
GJ64L1	407575	A.12
GJ64L2	408726	A.12
GJ64L3	407576	A.12
GJ64L4	407577	A.6
GJ64L5	408727	A.6
GJ64L6	407578	A.6
GJP	408057	A.27
<b>GK...</b>		
GK32N1	407591	A.13
GK32N3	407592	A.13
GK40N1	407595	A.13
GK40N3	407596	A.13
<b>GL...</b>		
GLD3F12		A.27
GLD3F3		A.27
GLD4F12		A.27
GLD4F3		A.27
GLHDR	408039	A.27
GLKAR		A.26
GLKMR		A.26
<b>GM...</b>		
GM01024D	407700	A.22
GM01024DR	407701	A.24
GM01048A	407710	A.22
GM01048D	407702	A.22
GM01048AR	407711	A.24
GM01060D	407704	A.22
GM01060DR	407705	A.24
GM01110D	407706	A.22
GM01110DR	407707	A.24
GM01120A	407712	A.22
GM01120AR	407713	A.24
GM01220D	407720	A.22
GM01220DR	407721	A.24
GM01240A	407714	A.22
GM01240AR	407715	A.24
GM01250D	407708	A.22
GM01250DR	407709	A.24
GM01400AR	407716	A.22
GM01400DR	407717	A.24
GM01440A	407718	A.22
GM01440AR	407719	A.24
GM02024D	407725	A.22
GM02024DR	407726	A.24
GM02048A	407735	A.22
GM02048D	407727	A.22
GM02048DR	407736	A.24
GM02060D	407729	A.22
GM02060DR	407730	A.24
GM02110D	407731	A.22

Cat. No.	Ref. No.	Page
GM02110DR	407732	A.24
GM02120A	407737	A.22
GM02120DR	407738	A.24
GM02220D	407722	A.22
GM02220DR	407723	A.24
GM02240A	407739	A.22
GM02240DR	407740	A.24
GM02250D	407733	A.22
GM02250DR	407734	A.24
GM02400A	407741	A.22
GM02400DR	407742	A.24
GM02440A	407743	A.22
GM02440DR	407744	A.24
GMCN	408035	A.23
GMCNR	408033	A.25
GMPU1	408790	A.26
GMPU2	408791	A.26
GMPU3	408792	A.26
GMPU4	408793	A.26
GMT0024D	444630	A.22
GMT0024DR	444641	A.24
GMT0048A	444247	A.22
GMT0048AR	444647	A.24
GMT0048D	444631	A.22
GMT0048DR	444642	A.24
GMT0060D	444248	A.22
GMT0060DR	444643	A.24
GMT0110D	444249	A.22
GMT0110DR	444644	A.24
GMT0120A	444250	A.22
GMT0120AR	444648	A.24
GMT0220D	444251	A.22
GMT0220DR	444645	A.24
GMT0240A	444638	A.22
GMT0240AR	444649	A.24
GMT0250D	444252	A.22
GMT0250DR	444646	A.24
GMT0400A	444639	A.22
GMT0400AR	444650	A.24
GMT0440A	444640	A.22
GMT0440AR	444651	A.24
<b>GN...</b>		
GNTK120	407753	A.22
GNTK240	407754	A.22
<b>GP...</b>		
GPBD	408040	A.23
GPPO	407987	A.25
<b>GR...</b>		
GREPM	408041	A.27
GRHDR	408042	A.27
GRHN	408043	A.33
GRONCS	407984	A.33
GRON	410609	A.25
GRRC024D	407760	A.22
GRRC110	407762	A.22
GRRC230	407764	A.22
GRTC1	407897	A.22
GRTC2	407899	A.22
GRTC3	407894	A.22
GRTC4	407908	A.22
GRTC5	407909	A.22
GRTC6	407910	A.22
<b>GS...</b>		
GSDFTR1	408052	A.33
GSDFTR2	408030	A.33
GSDFTR3	408054	A.33
GSST024	407789	A.22
GSST024R	407790	A.24
GSST120	407791	A.22
GSST120R	407792	A.24
GSST240	407793	A.22
GSST240R	407794	A.24
GSTR024D	407770	A.22
GSTR024DR	407771	A.24
GSTR030D	407786	A.22
GSTR030DR	407787	A.24
GSTR048	407772	A.22
GSTR048R	407773	A.24
GSTR060D	407774	A.22
GSTR060DR	407775	A.24
GSTR		

# EntelliGuard\* G

## By catalogue number

Numerical index

Cat. No.	Ref. No.	Page
<b>GSTR440AR</b>	407785	A.24
<b>GT</b>		
<b>GT04K1</b>	444506	A.9
<b>GT04K2</b>	444726	A.9
<b>GT04K3</b>	444526	A.9
<b>GT04K4</b>	444548	A.4
<b>GT04K5</b>	444746	A.4
<b>GT04K6</b>	444569	A.4
<b>GT04R1</b>	444500	A.9
<b>GT04R2</b>	444720	A.9
<b>GT04R3</b>	444520	A.9
<b>GT04R4</b>	444542	A.4
<b>GT04R5</b>	444740	A.4
<b>GT04R6</b>	444563	A.4
<b>GT07K1</b>	444507	A.9
<b>GT07K2</b>	444727	A.9
<b>GT07K3</b>	444527	A.9
<b>GT07K4</b>	444549	A.4
<b>GT07K5</b>	444747	A.4
<b>GT07K6</b>	444570	A.4
<b>GT07R1</b>	444501	A.9
<b>GT07R2</b>	444721	A.9
<b>GT07R3</b>	444521	A.9
<b>GT07R4</b>	444543	A.4
<b>GT07R5</b>	444741	A.4
<b>GT07R6</b>	444564	A.4
<b>GT08K1</b>	444508	A.9
<b>GT08K2</b>	444728	A.9
<b>GT08K3</b>	444528	A.9
<b>GT08K4</b>	444550	A.4
<b>GT08K5</b>	444748	A.4
<b>GT08K6</b>	444571	A.4
<b>GT08R1</b>	444502	A.9
<b>GT08R2</b>	444722	A.9
<b>GT08R3</b>	444522	A.9
<b>GT08R4</b>	444544	A.4
<b>GT08R5</b>	444742	A.4
<b>GT08R6</b>	444565	A.4
<b>GT10K1</b>	444509	A.9
<b>GT10K2</b>	444729	A.9
<b>GT10K3</b>	444529	A.9
<b>GT10K4</b>	444551	A.4
<b>GT10K5</b>	444749	A.4
<b>GT10K6</b>	444572	A.4
<b>GT10R1</b>	444503	A.9
<b>GT10R2</b>	444723	A.9
<b>GT10R3</b>	444523	A.9
<b>GT10R4</b>	444545	A.4
<b>GT10R5</b>	444743	A.4
<b>GT10R6</b>	444566	A.4
<b>GT12FAD</b>	444675	A.23
<b>GT12WAD</b>	444676	A.23
<b>GT13FB</b>	444677	A.23
<b>GT13FC</b>	444679	A.23
<b>GT13FDT</b>	444681	A.23
<b>GT13K1</b>	444510	A.9
<b>GT13K2</b>	444730	A.9
<b>GT13K3</b>	444530	A.9
<b>GT13K4</b>	444552	A.4
<b>GT13K5</b>	444750	A.4
<b>GT13K6</b>	444573	A.4
<b>GT13R1</b>	444504	A.9
<b>GT13R2</b>	444724	A.9
<b>GT13R3</b>	444524	A.9
<b>GT13R4</b>	444546	A.4
<b>GT13R5</b>	444744	A.4
<b>GT13R6</b>	444567	A.4
<b>GT13WB</b>	444678	A.23
<b>GT13WC</b>	444680	A.23
<b>GT13WDT</b>	444682	A.23
<b>GT16H3UNIR</b>	410705	A.14
<b>GT16H4FFI</b>	444625	A.7
<b>GT16H4RVI</b>	444626	A.7
<b>GT16H6FFI</b>	444627	A.7
<b>GT16H6RVI</b>	444628	A.7
<b>GT16H7UNIR</b>	410706	A.14
<b>GT16K1</b>	444511	A.9
<b>GT16K2</b>	444731	A.9
<b>GT16K2FXXXXXM</b>	444690	A.15
<b>GT16K2FXXXXXR</b>	444700	A.29
<b>GT16K2HXXXXXM</b>	444692	A.14
<b>GT16K2HXXXXXR</b>	444702	A.29
<b>GT16K2UXXXXXM</b>	444691	A.14
<b>GT16K2UXXXXXR</b>	444701	A.29
<b>GT16K2ZXXXXM</b>	444513	A.29
<b>GT16K2ZXXXXR</b>	444512	A.15
<b>GT16K3</b>	444531	A.9
<b>GT16K4</b>	444553	A.4
<b>GT16K5</b>	444751	A.4
<b>GT16K5FXXXXXM</b>	444693	A.15
<b>GT16K5FXXXXXR</b>	444703	A.29
<b>GT16K5HXXXXXM</b>	444695	A.14

Cat. No.	Ref. No.	Page
<b>GT16K5HXXXXXR</b>	444705	A.29
<b>GT16K5UXXXXXM</b>	444694	A.14
<b>GT16K5UXXXXXR</b>	444704	A.29
<b>GT16K5XXXXR</b>	444515	A.29
<b>GT16K5XXXXXM</b>	444514	A.15
<b>GT16K6</b>	444574	A.4
<b>GT16KARC</b>	444802	A.33
<b>GT16KCHT</b>	444801	A.33
<b>GT16KCLS</b>	444800	A.33
<b>GT16N2SSL</b>	444253	A.33
<b>GT16N5SSL</b>	444254	A.33
<b>GT16R1</b>	444505	A.9
<b>GT16R2</b>	444725	A.9
<b>GT16R3</b>	444525	A.9
<b>GT16R4</b>	444547	A.4
<b>GT16R5</b>	444745	A.4
<b>GT16R6</b>	444568	A.4
<b>GTAS3</b>	444655	A.22
<b>GTAS3R</b>	444658	A.24
<b>GTAS4</b>	444656	A.22
<b>GTAS4R</b>	444659	A.24
<b>GTBAT1</b>	444660	A.22
<b>GTBAT1R</b>	444672	A.24
<b>GTBATS1</b>	444661	A.22
<b>GTBATS1R</b>	444673	A.24
<b>GTBPRO</b>	444665	A.23
<b>GTBRON</b>	444666	A.23
<b>GTCPRO</b>	444668	A.23
<b>GTCPS1</b>	444790	A.22
<b>GTCPS1R</b>	444791	A.24
<b>GTCPS2</b>	444792	A.22
<b>GTCPS2R</b>	444793	A.24
<b>GTCPSA</b>	444794	A.22
<b>GTCPSAR</b>	444795	A.24
<b>GTCRON</b>	444669	A.23
<b>GTDEDT</b>	287031	A.27
<b>GTDEFD</b>	287032	A.27
<b>GTD M048A</b>	407816	A.26
<b>GTD M060D</b>	407817	A.26
<b>GTD M120A</b>	407818	A.26
<b>GTD M120D</b>	407819	A.26
<b>GTD M240A</b>	407820	A.26
<b>GTD M240D</b>	407821	A.26
<b>GTD M250D</b>	407823	A.26
<b>GTD M277A</b>	407822	A.26
<b>GTD M400A</b>	407824	A.26
<b>GTD M440A</b>	407825	A.26
<b>GTDPFR</b>	444805	A.27
<b>GT FAL</b>	444804	A.33
<b>GTG00K1XXSFXXXX</b>	408800	A.16
<b>GTG00K2XXSFXXXX</b>	408801	A.16
<b>GTG00K2XXSRXXXX</b>	408802	A.31
<b>GTG00K3T6SF</b>	408817	A.17
<b>GTG00K3X2SFXXXX</b>	408807	A.16
<b>GTG00K3X4SFXXXX</b>	408815	A.17
<b>GTG00K3XXSFXXXX</b>	408805	A.16
<b>GTG00K4T6SFXXXX</b>	408818	A.17
<b>GTG00K4T6XXSR</b>	408819	A.31
<b>GTG00K4X2SFXXXX</b>	408808	A.16
<b>GTG00K4X4SFXXXX</b>	408816	A.17
<b>GTG00K4XX2XXSR</b>	408809	A.31
<b>GTG00K4XXSFXXXX</b>	408806	A.16
<b>GTG00K9X4SFXXXX</b>	408813	A.17
<b>GTG00K9XX2FXXXXX</b>	408803	A.16
<b>GTG00N5T5SFXXXX</b>	408829	A.18
<b>GTG00N5T8SFXXXX</b>	408837	A.18
<b>GTG00N5T8XXSR</b>	408849	A.32
<b>GTG00N5T9SFXXXX</b>	408845	A.18
<b>GTG00N5T9XXSR</b>	408853	A.32
<b>GTG00N5X5SFXXXX</b>	408825	A.18
<b>GTG00N5X8SFXXXX</b>	408833	A.18
<b>GTG00N5X9SFXXXX</b>	408841	A.18
<b>GTG00N6T5SFXXXX</b>	408830	A.20
<b>GTG00N6T8SFXXXX</b>	408838	A.20
<b>GTG00N6T8XXSR</b>	408850	A.32
<b>GTG00N6T9SFXXXX</b>	408846	A.20
<b>GTG00N6T9XXSR</b>	408854	A.32
<b>GTG00N6X5SFXXXX</b>	408826	A.20
<b>GTG00N6X8SFXXXX</b>	408834	A.20
<b>GTG00N6X9SFXXXX</b>	408842	A.20
<b>GTG00N7T5SFXXXX</b>	408831	A.19
<b>GTG00N7T8SFXXXX</b>	408839	A.19
<b>GTG00N7T8XXSR</b>	408851	A.32
<b>GTG00N7T9SFXXXX</b>	408847	A.19
<b>GTG00N7T9XXSR</b>	408855	A.32
<b>GTG00N7X5SFXXXX</b>	408827	A.19
<b>GTG00N7X8SFXXXX</b>	408835	A.19
<b>GTG00N7X9SFXXXX</b>	408843	A.19
<b>GTG00N8T5SFXXXX</b>	408832	A.20
<b>GTG00N8T8SFXXXX</b>	408840	A.20
<b>GTG00N8T8XXSR</b>	408852	A.32
<b>GTG00N8T9SFXXXX</b>	408848	A.20

Cat. No.	Ref. No.	Page
<b>GTG00N8T9XXSR</b>	408856	A.32
<b>GTG00N8X5SFXXXX</b>	408828	A.20
<b>GTG00N8X8SFXXXX</b>	408836	A.20
<b>GTG00N8X9SFXXXX</b>	408844	A.20
<b>GTG00N9S5SFXXXX</b>	408823	A.18
<b>GTG00N9X8SFXXXX</b>	408863	A.18
<b>GTG00N9X9SFXXXX</b>	408865	A.18
<b>GTG00NDT5SFXXXX</b>	408750	A.21
<b>GTG00NDT8SFXXXX</b>	408751	A.21
<b>GTG00NDT9SFXXXX</b>	408753	A.21
<b>GTG00NDX5SFXXXX</b>	408755	A.21
<b>GTG00NDX8SFXXXX</b>	408756	A.21
<b>GTG00NDX9SFXXXX</b>	408757	A.21
<b>GTG00NFT5SFXXXX</b>	408758	A.21
<b>GTG00NFT8SFXXXX</b>	408759	A.21
<b>GTG00NFT9SFXXXX</b>	408761	A.21
<b>GTG00NF5SFXXXX</b>	408763	A.21
<b>GTG00NF8SFXXXX</b>	408764	A.21
<b>GTG00NF9SFXXXX</b>	408765	A.21
<b>GTHDTUD</b>	444711	A.33
<b>GTHDTUF</b>	444710	A.33
<b>GTJDP</b>	444255	A.22
<b>GTLHDR</b>	444256	A.22
<b>GTBDR</b>	444667	A.27
<b>GTBPRW</b>	444806	A.27
<b>GTBUNI</b>	408860	A.16
<b>GTREPM</b>	444674	A.27
<b>GTRHDR</b>	444257	A.27
<b>GTRHN</b>	444803	A.33
<b>GTSDFTR</b>	444258	A.33
<b>GTSDWTR</b>	444259	A.33
<b>GTRUSK</b>	408780	A.26
<b>GTUS</b>	408046	A.26
<b>GTUTK20</b>	407999	A.26
<b>GU...</b>		
<b>GUNI</b>	408047	A.33
<b>GUVR240</b>	407811	A.22
<b>GUVR240R</b>	407812	A.24
<b>GUVT024D</b>	407795	A.22
<b>GUVT024DR</b>	407796	A.24
<b>GUVT048</b>	407797	A.22
<b>GUVT048R</b>	407798	A.24
<b>GUVT060D</b>	407799	A.22
<b>GUVT060DR</b>	407800	A.24
<b>GUVT120</b>	407801	A.22
<b>GUVT120R</b>	407802	A.24
<b>GUVT400</b>	407803	A.22
<b>GUVT240R</b>	407804	A.22
<b>GUVT277</b>	407805	A.24
<b>GUVT277R</b>	407806	A.24
<b>GUVT400A</b>	407807	A.22
<b>GUVT400AR</b>	407808	A.24
<b>GUVT440A</b>	407809	A.22
<b>GUVT440AR</b>	407810	A.24
<b>GW...</b>		
<b>GW04M1</b>	408400	A.12
<b>GW04M2</b>	408710	A.12
<b>GW04M3</b>	408401	A.12
<b>GW04M4</b>	408350	A.6
<b>GW04M5</b>	408712	A.6
<b>GW04M6</b>	408351	A.6
<b>GW04N1</b>	407374	A.12
<b>GW04N2</b>	408611	A.12
<b>GW04N3</b>	407375	A.12
<b>GW04N4</b>	407376	A.6
<b>GW04N5</b>	408613	A.6
<b>GW04N6</b>	407377	A.6
<b>GW07M1</b>	408402	A.12
<b>GW07M2</b>	408714	A.12
<b>GW07M3</b>	408403	A.12
<b>GW07M4</b>	408352	A.6
<b>GW07M5</b>	408651	A.6
<b>GW07M6</b>	408353	A.6
<b>GW07N1</b>	407394	A.12
<b>GW07N2</b>	408615	A.12
<b>GW07N3</b>	407395	A.12
<b>GW07N4</b>	407396	A.6
<b>GW07N5</b>	408617	A.6
<b>GW07N6</b>	407397	A.6
<b>GW08M1</b>	408404	A.12
<b>GW08M2</b>	408653	A.12
<b>GW08M3</b>	408405	A.12
<b>GW08M4</b>	408354	A.6
<b>GW08M5</b>	408655	A.6
<b>GW08M6</b>	408355	A.6
<b>GW08N1</b>	407414	A.12
<b>GW08N2</b>	408619	A.12
<b>GW08N3</b>	407415	A.12
<b>GW08N4</b>	407416	A.6
<b>GW08N5</b>	408621	A.6
<b>GW08N6</b>	407417	A.6
<b>GW10M1</b>	408406	A.12



Since Thomas Edison patented the world's first circuit breaker, Industrial Solutions has been transforming the future of electrification. We design electrical solutions at the crossroads of digital and industrial – smart, rugged and equipped to control electricity from the grid to its point of use. Every day, we partner with our customers to solve their toughest energy challenges and reimagine industry in a way that only the world's digital industrial company can.

## Belgium

GE Industrial Belgium  
Nieuwevaart 51  
B-9000 Gent  
Tel. +32 (0)9 265 21 11

## Finland

GE Industrial Solutions  
Kuortaneenkatu 2  
FI-00510 Helsinki  
Tel. +358 (0)10 394 3760

## France

GE Industrial Solutions  
204, Rue du Rond-Point du Pont de Sèvres  
F-92100 Boulogne-Billancourt  
Tel. +33 (0)800 912 816

## Germany

GE Industrial Solutions  
Robert-Bosch Str. 3  
D-50354 Hürth-Efferen  
Tel. +49 (0) 2233/ 9719-0

## Hungary

GE Hungary Kft.  
Váci ut 81-83.  
H-1139 Budapest  
Tel. +36 1 447 6050

## Italy

GE Industrial Solutions  
Centro Direzionale Colleoni  
Via Paracelso 16  
Palazzo Andromeda B1  
I-20864 Agrate Brianza (MB)  
Tel. +39 039 637 371

## Netherlands

GE Industrial Solutions  
Parallelweg 10  
NL-7482 CA Haaksbergen  
Tel. +31 (0)53 573 03 03

## North Africa

General Electric International,  
sq Inc. (Succursale)  
Crystal Building 3,  
3rd Floor, Marina Casablanca,  
20050 Casablanca, Morocco  
Tel. +212 529 025 502

## Norway

GE Industrial Solutions  
Drammensveien 165  
0277 Oslo  
Tel. +47 (0)8 001 72 56

## Poland

GE Power Controls  
Gdanski Business Centre  
Inflancka 4C, bud. D  
00-189 Warszawa  
Tel. +48 22 520 53 53

## Rudawka 96

43-382 Bielsko-Biała  
Tel. +48 33 828 62 33

## Russia

GE Industrial Solutions  
27/8, Electrozavodskaya street  
Moscow, 107023  
Tel. +7 495 937 11 11

## South Africa

GE Industrial Solutions  
Unit 4, 130 Gazelle Avenue  
Corporate Park Midrand 1685  
P.O. Box 76672 Wendywood 2144  
Tel. +27 11 238 3000

## Spain

GE POWER CONTROLS IBÉRICA, S.L.  
Calle Miño 122 Naves E-F  
Polígono Industrial Santa Margarita  
08223 Terrassa (Barcelona)  
Tel. +34 900 993 625

## Sweden

GE Industrial Slutions  
Vendevägen 89  
SE-182 32 Danderyd  
Tel. +46 (0)20 79 16 70

## United Arab Emirates

GE Industrial Solutions  
Injaz Building, 3rd Floor  
Dubai Internet City  
PO Box 11549, Dubai  
Tel. +971 4 4546912

## United Kingdom

GE Industrial Solutions  
2 The Arena, Downshire Way  
Bracknell, Berkshire  
RG12 1PU  
Tel. +44 (0)800 587 1239

