

Controls and Power Electronics

For industrial applications



POWER DEVICES

Contactors and overload relays

Intro

A

Auxiliary relays and contactors

B

Motor protection devices

C

Applications

D

AUXILIARY DEVICES

Main switches

E

Control and signalling units

F

POWER ELECTRONICS

Speed drive units

G

Soft starters

H

ENCLOSURES

Product overview

I

Alphabetical index

X



POWER DEVICES

A

Contactors and thermal overload relays

Efficor - Global contactors



Compact starter either with thermal overload relay or manual motor starter.

- A.7

Series EA - Minicontactors



Three pole minicontactors
7A (AC3)
16A (AC1)

- A.31

Series M - Compact contactors



3 and 4P (4NO, 2NO+2NC, 4NC)
6, 9 and 12A (AC-3)
20A (AC-1) Control circuit AC
and DC

- A.33

Series CL - Contactors



3 and 4P (4NO, 2NO+2NC) 9 to
105A (AC-3) 25 to 140A
(AC-1) AC, DC and with electronic
module

- A.41

Series CK - Contactors

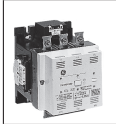

3 and 4P (4NO) 150 to 825A (AC-3)
200 to 1250A (AC-1)
AC, DC and with electronic module

- A.48

Series MTO - Thermal overload relays



For compact contactors series M
from 0.11 to 14A

- A.52

Series RT - Thermal overload relays



For contactors Efficor, series CL
and CK from 0.16 to 850A
Class 10A, 10, 20, 30

- A.54

Series RE - Electronic overload relays



For contactors Efficor, series CL
from 0.1 to 150A

- A.58

EntelliPro



Intelligent motor management
relay

- A.60

B

Plug-in relays and auxiliary contactors

Series PRC - Plug-in relays



Miniature plug-in relays
Standard 8-11 pin plug-in relays
Interface relay

- B.2

Series M - Auxiliary contactors

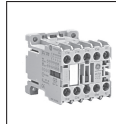

I_{th} = 16A

- B.8

Series RL - Auxiliary contactors



I_{th} = 20A

- B.14

Series EC - Auxiliary contactors



I_{th} = 20A
Double box clamp terminal

- B.17

C

Motor protection devices

Surion - Manual motor starter



Thermal and magnetic protection -
Magnetic protection only
Setting ranges from 0.1 to 63A

- C.2

Series SFK - Motor protection circuit breaker



Thermal and magnetic protection of
AC and DC motors
Setting ranges from 0.1 to 25A

- C.26

D

Applications

Technical data

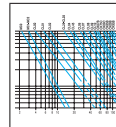

Utilization categories
Electrical endurance
Machine directive -
B10d value for contactors

- D.3-D.8

Selection tables

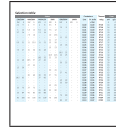

- D.9-D.41

Dimensional drawings

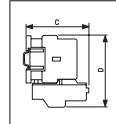

- D.76

AUXILIARY DEVICES

E

Main switches

Series ML



Standard programme
Main switches and emergency-stop switches for machinery

enclosed switches

- E.4

Switches for photovoltaic applications



To isolate the solar panels from the inverter, from 16 to 100Adc

- E.13

F

Control and signalling units

Series P9 - Panel mounting - Units Ø 22 mm



- F.14

Series P9 - Base mounting



- F.24

Series P9 - Push-button stations / Equipped boxes



- F.28

Series P9 - Common accessories



- F.34

Series 077 - Units Ø 30 mm



- F.44

Series 105 - Signalling devices



- F.61

POWER ELECTRONICS

G

Speed drive units

AF7 drives



Drives designed for general purpose applications

- G.8

AF6 drives



Drives designed for general purpose applications

- G.28

H

Softstarters

ASTAT XB - XBm



Small soft starter with integral by-pass

- H.13

ASTAT XL



Digital soft starter for 3 phase standard induction motors

- H.14

ENCLOSURES

I

Product overview

Enclosures



System Enclosures /
Distribution Boards
General Purpose Enclosures

- I.1

X

Alphabetical index

By Catalog number

Visit ex.geindustrial.com and click on

Product Selector

Home > Products > Motors & Lighting Control > Power devices

Power devices

Efficient electro-mechanical solutions for motor starter applications.

[Product Selector](#)

Contactors

In the last 15 years, GE contactors demonstrated their reliability and are the main part of diverse applications. Efficor is the new range of contactors and motor starting solutions with high performances and for any motor starting application, being totally qualified to use from railway up to industrial sectors. Designed to work under the toughest environmental conditions.



Efficor - Reliable starter solutions up to 105A
Provides Starter and Power Switching Solutions for OEMs and Panel Builders working in the toughest markets.



Series EA - Mini contactor series 7A



Series M - Compact contactor up to 12A



Series CL - General purpose application up to 105A



Series CK - Contactor from 150 up to 700A - High efficiency coil

Related Publications

- Articles
- Brochures
- Catalogs and Buyers Guides
- Drawings - CAD - 3D
- Pricelist

- All product info available in one central place
- All product info is available to download, print or e-mail
- Always the latest up-to-date info

Home > Products > Services > Industries > Resources > Your Business > News & Events > Where To Buy

Products > Power devices > Contactors > 6. Series M: Auxiliary contactors 16A 1th screw terminal



View Larger

Ref. No. : 100000 | Cat. No. : MCRCD40ATB
Description: Screw terminal, 4NO, 12V DC (GE)
EAN: 8425095000001

- Control circuit:

[View More](#)
For more info visit: uk.geindustrial.com

Specifications	
Descriptors	
Category	6. Series M: Auxiliary contactors 16A 1th screw terminal
Specifications	
Series	Auxiliary minicontactors (1th - 16A)
Control circuit	DC
Terminal	Screw terminal
Control Voltage: DC	12 V
Contacts acc. To EN 50011	4NO
Number of contacts	4
Utilisation category AC15	110/120V - 6A, 220/240V - 6A, 380/400V - 4A, 415/440V - 4A, 500V - 2.5A, 660/690V - 1.5A
Utilisation category DC13	110V - 1.2A, 220V - 0.5A, 24V - 5A, 440V - 0.25A, 48V - 3.5A

- Use the **Quick-search** using a **part number** or **keyword**
- Find a product by using the **parametric search**, simply enter the technical characteristics you are looking for
- **Compare** up to 4 products and view the technical data and accessories on a single page
- **High resolution images** are available by clicking on the small product image
- Product pages contain all available data: **technical specifications, dimensional drawings, product descriptions, ...**
- **CAD drawings** are available for download into productpages
- The data also displays the **available functions and accessories** for each product

Home > Products > Services > Industries > Resources > Your Business > News & Events > Where To Buy

Products > Power devices > Contactors

Refine Your Results [clear](#)

2,550 products match your selections

Display 25 per page [Compare](#)

Image	Ref. No.	Cat. No.	Description
	100000	MCRCD40ATB	Screw terminal, 4NO, 12V DC (GE)
	100001	MCRAD40ATD	Screw terminal, 4NO, 24V/50Hz AC (GE)
	100002	MCRAD40ATG	Screw terminal, 4NO, 48V/50Hz/60V/60Hz AC (GE)
	100003	MCRAD40ATJ	Screw terminal, 4NO, 110V/50Hz/120V/60Hz AC (GE)

High resolution images available

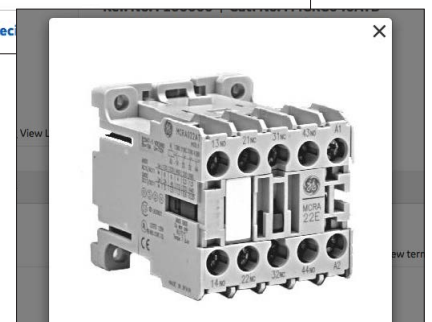

Contactors and Overload Relays

A.2 Overview

Order codes

A.6 New **Efficor** global contactors

A.31 **Series EA** - Three pole minicontactors

A.33 **Series M** - Three and four pole compact contactors

A.41 **Series CL** - Three and four pole contactors

A.48 **Series CK** - Three and four pole contactors

A.52 **Series MTO** - Thermal overload relays

A.54 **Series RT** - Thermal overload relays

A.58 **Series RE** - Electronic overload relays

A.60 **EntelliPro** - Intelligent motor management relays

POWER DEVICES

Contactors and overload relays

Technical data

A.66 Efficor

A.79 Series M

A.88 Series CL

A.99 Series CK

A.130 Series MTO

A.132 Series RT

A.138 Series RE

Dimensional drawings

A.107 Efficor

A.118 Series M

A.120 Series CL

A.126 Series CK

A.131 Series MTO

A.136 Series RT

A.138 Series RE

AUXILIARY DEVICES

POWER ELECTRONICS

ENCLOSURES

Auxiliary relays and contactors

Motor protection devices

Applications

Main switches

Control and signalling units

Speed drive units

Soft starters

Product overview

Alphabetical index

Intro

A

B

C

D

E

F

G

H

I

X



Contactors and Overload Relays

IEC operational rated current	AC3	A
	AC1	A
IEC rated operational power	220-240 V	kW
	380-415 V	kW
	690 V	kW
UL/CSA 3-phase motor rating	220-240 V	hp
	380-415 V	hp
	440-480 V	hp
	550-600 V	hp
Terminal capacity		mm ² Max.
		AWG

3 Poles	AC
	DC
4 Poles	AC/DC
	AC
2NO + 2NC	DC
	AC/DC

Coil selection	
Replace ◆ by the coil code	

Suppressor	
-------------------	--

Main accessories	
Frontal accessories	

Lateral aux. contact	
-----------------------------	--

Interlock	
------------------	--

Thermal overload relay Class 10	
--	--

Electronic overload relay Class selectable 5,10,20 and 30	
--	--

Surion Manual Motor Starter	
------------------------------------	--

Link module contactor + MMS	
------------------------------------	--

EA	
	7
	16
	1.5
	3
	-
	3
	3
	3
	-
	2x2.5
	16-12

EA07A310S ◆
EA07D310S ◆
-
-
-
-
-
-
-
-

Replace ◆ by the coil code

Coil voltage AC	Code
24V 50/60 Hz	024
48V 50/60Hz	048
110V 50/60Hz	110
230V 50/60 Hz	230
Coil voltage DC	Code
24V	024
110V	110

M	
	9
	20
	2.2
	4
	7.5
	3
	5
	5
	7.5
	10
	2x2.5
	18-12

MC1A310AT ◆	MC2A310AT ◆
MC1C310AT ◆	MC2C310AT ◆
-	-
MC1A400AT ◆	MC2A400AT ◆
MC1C400AT ◆	MC2C400AT ◆
-	-
MC1A800AT ◆	MC2A800AT ◆
MC1C800AT ◆	MC2C800AT ◆
-	-

Replace ◆ by the coil code

Coil voltage AC	Code
24V 50/60 Hz	1
110-115V 50Hz 120V 60Hz	J
208-220V 60Hz	M
220-230V 50/60 Hz	6
380-400V 50Hz 440V 60Hz	U
Coil voltage DC	Code
24V -20% +10%	D
24V ±30%	WD
110V ±30%	WJ
125V ±30%	WL

Type	Code
R/C 12-60Vac 50/60 Hz	MP0AAE01
R/C 72-250Vac 50/60 Hz	MP0AAE02
Diode 6-250Vdc	MPOCAE03
Varistor 24-48Vac/dc	MPODAE04

Contacts	Code
2NO	MARN220AT
1NO + 1NC	MARN211AT
2NC	MARN202AT
4NO	MARN440AT
3NO + 1NC	MARN431AT
2NO + 2NC	MARN422AT
1NO + 3NC	MARN413AT
4NC	MARN404AT

Contacts	Code
1NO	MACL110AT
1NC	MACL101AT

	Code
	MMH0

Setting range (A)	Code
0.11-0.17	MT03A
0.17-0.26	MT03B
0.26-0.43	MT03C
0.43-0.65	MT03D
0.65-1	MT03E
0.85-1.3	MT03F
1.1-1.6	MT03G
1.35-2	MT03H
1.7-2.4	MT03I
2.2-3.2	MT03J
2.5-4	MT03R
3-4.7	MT03K
4-6.3	MT03L
5.5-8	MT03M
7.5-10.5	MT03N
10-14	MT03P
Base for separate mounting	MVBOT

Electronic overload relay Class selectable 5,10,20 and 30	
--	--

Surion Manual Motor Starter	
------------------------------------	--

	GPS1+M
	GPF1LMCBA

Contactors and Overload Relays

EC					
9	12	18	25	32	40
25	25	32	45	60	60
2,2	3	4	7,5	9	11
4	5,5	7,5	11	15	18,5
7,5	11	15	22	30	37
3	4	5,5	7,5	10	10
5,5	7,5	10	15	15	20
5,5	7,5	10	15	20	25
7,5	10	15	20	20	20
2x6	2x6	2x6	2x10	2x16	2x16
18-10	18-10	18-10	18-8	18-6	18-6

EC09A311B ◆	EC12A311B ◆	EC18A311B ◆	EC25A311B ◆	EC32A300B ◆	EC40A300B ◆
EC09D311B ◆	EC12D311B ◆	EC18D311B ◆	EC25D311B ◆	EC32D300B ◆	EC40D300B ◆
EC09E311B ◆	EC12E311B ◆	EC18E311B ◆	EC25E311B ◆	EC32E300B ◆	EC40E300B ◆
EC09A400B ◆	EC12A400B ◆	EC18A400B ◆	EC25A400B ◆	EC32A400B ◆	EC40A400B ◆
EC09D400B ◆	EC12D400B ◆	EC18D400B ◆	EC25D400B ◆	EC32D400B ◆	EC40D400B ◆
EC09E400B ◆	EC12E400B ◆	EC18E400B ◆	EC25E400B ◆	EC32E400B ◆	EC40E400B ◆
-	EC12AB00B ◆	EC18AB00B ◆	EC25AB00B ◆	EC32AB00B ◆	-
-	EC12DB00B ◆	EC18DB00B ◆	EC25DB00B ◆	EC32DB00B ◆	-
-	EC12EB00B ◆	EC18EB00B ◆	EC25EB00B ◆	EC32EB00B ◆	-

Replace ◆ by the coil code

Coil voltage AC	Code
24V 50/60 Hz	024
110V 50/60 Hz	110
120V 50/60 Hz	120
208V 50/60 Hz	208
230 50/60 Hz	230
400V 50/60 Hz	400

Coil voltage DC	Code
24V -20% +10% Low consumption	024L

Super Wide Coil Voltage AC/DC	Code
24-60V AC/DC -30% +10%	24-60
48-130V AC/DC -20% +10%	48-130
100-250V AC/DC -20% +10%	100-250

Type	Code
R/C 24-48Vac 50/60 Hz	ECSURC048
R/C 50-127Vac 50/60 Hz	ECSURC127
R/C 130-250Vac 50/60 Hz	ECSURC250
Diode 12-440Vdc	ECSUDI440
Varistor 24-48Vac/dc	ECSUVA048
Varistor 50-127 Vac/dc	ECSUVA127

Setting time	Code
0.1-30 s delay ON	ECPT30SC
1-60 s delay ON	ECPT60SC
0.1-30 s delay OFF	ECPT30SD
1-60 s delay OFF	ECPT60SD

Contacts	Code
2NO	ECFA220S
1NO + 1NC	ECFA211S
2NC	ECFA202S

Contacts	Code
2NO	ECLA220S
1NO + 1NC	ECLA211S
2NC	ECLA202S

Note: EC*E Lateral Auxiliary can only be mounted on right side

Contacts	Code
-	ECMI
2NC	ECMI02S

Setting range (A)	Code
0.16-0.26 A	ECRT1B10B
0.25-0.41 A	ECRT1B10C
0.4-0.65 A	ECRT1B10D
0.65-1.10 A	ECRT1B10F
1-1.5 A	ECRT1B10G
1.3-1.9 A	ECRT1B10H
1.8-2.7 A	ECRT1B10J
2.5-4 A	ECRT1B10K
4-6.3 A	ECRT1B10L
5.5-8.5 A	ECRT1B10M
8-12 A	ECRT1B10N
10-16 A	ECRT1B10P
14.5-18 A	ECRT1B10S
17.5-22 A	ECRT1B10T

Base for separate mounting ECRT1BS

Setting range (A)	Code
8-12 A	ECRT2B10N
10-16 A	ECRT2B10P
14.5-18 A	ECRT2B10S
17.5-22 A	ECRT2B10T
21-26 A	ECRT2B10U
25-32 A	ECRT2B10V
30-40 A	ECRT2B10W

Base for separate mounting ECRT2BS

Setting range (A)	Code
0.1-0.5	RE1D
0.4-2	RE1H
1-5	RE1K
1.6-8	RE1M
6.4-32	RE1S
9-45	RE1W

Base for separate mounting RE1XP

Setting range (A)	Code Rocket	Code Rotary
0.1 - 0.16	GPS1BSAA	GPS1BHAA
0.16 - 0.25	GPS1BSAB	GPS1BHAB
0.25 - 0.4	GPS1BSAC	GPS1BHAC
0.4 - 0.63	GPS1BSAD	GPS1BHAD
0.63 - 1	GPS1BSAE	GPS1BHA
1 - 1.6	GPS1BSAF	GPS1BHAF
1.6 - 2.5	GPS1BSAG	GPS1BHAG
2.5 - 4	GPS1BSAH	GPS1BHAH
4 - 6.3	GPS1BSAJ	GPS1BHAJ
6.3 - 10	GPS1BSAK	GPS1BHAJ
9 - 13	GPS1BSAL	GPS1BHAL
11 - 16	GPS1BSAM	GPS1BHAM
14 - 20	GPS1BSAN	GPS1BHAN
19 - 25	GPS1BSAP	GPS1BHAP
24 - 32	GPS1BSAR	GPS1BHAR

Setting range (A)	Code Rotary
28 - 40	GPS2BHAS

GPS1 + EC09A to EC25A ECM1AL25	GPS1 + EC09E to EC25E ECM1AL25	GPS1 + EC32A ECM1AL32	GPS2 + EC32A to EC40A ECM2AL40	GPS1 + EC32E ECM1AL32	GPS2 + EC32E to EC40E ECM2AL40
-----------------------------------	-----------------------------------	--------------------------	-----------------------------------	--------------------------	-----------------------------------

Contactors and Overload Relays

IEC operational rated current	AC3	A
	AC1	A
IEC rated operational power	220-240 V	kW
	380-415 V	kW
	690 V	kW
UL/CSA 3-phase motor rating	220-240 V	hp
	380-415 V	hp
	440-480 V	hp
	550-600 V	hp
Terminal capacity		mm ² Max.
		AWG

3 Poles	AC
	DC
4 Poles	AC/DC
	DC
2NO + 2NC	AC
	DC
	AC/DC

Coil selection
Replace ◆ by the coil code

Suppressor

Main accessories
Frontal accessories

Lateral aux. contact

Interlock

Thermal overload relay Class 10

Electronic overload relay Class selectable 5,10,20 and 30

Surion
Manual Motor Starter

Link module contactor + MMS

EF					
40	50	65	80	95	105
90	90	110	110	140	140
11	11	18.5	22	25	30
18.5	22	30	37	45	55
37	45	55	75	90	90
15	15	20	25	30	40
20	30	40	50	60	75
30	30	40	50	60	75
30	40	50	60	75	75
1x35 or 1x20+1x16 13-2	1x35 or 1x20+1x16 13-2	1x35 or 1x20+1x16 13-2	1x35 or 1x20+1x16 13-2	1x50 or 1x35+1x25 11-1/0	1x50 or 1x35+1x25 11-1/0

-	EF50A300B ◆	EF65A300B ◆	EF80A300B ◆	EF95A300B ◆	EF105A300B ◆
-	EF50E300B ◆	EF65E300B ◆	EF80E300B ◆	EF95E300B ◆	EF105E300B ◆
-	EF50A400B ◆	-	EF80A400B ◆	EF95A400B ◆	-
-	EF50E400B ◆	-	EF80E400B ◆	EF95E400B ◆	-
EF40AB00B ◆	-	EF65AB00B ◆	EF80AB00B ◆	-	-
-	-	-	-	-	-
EF40EB00B ◆	-	EF65EB00B ◆	EF80EB00B ◆	-	-

Replace ◆ by the coil code

Coil voltage AC		Code
24V 50/60 Hz		024
110V 50/60 Hz 120V 60Hz		110
230 50/60 Hz		230
400V 50/60 Hz		400

Super Wide Coil Voltage AC/DC		Code
24-60V AC/DC -30%+10%		24-60
48-130V AC/DC -20%+10%		48-130
100-250V AC/DC -20%+10%		100-250
250-500V AC/DCV -20%+10%		250-500

Type	Code
R/C 12-60Vac 50/60 Hz	MP0AAE01
R/C 72-250Vac 50/60 Hz	MP0AAE02
Diode 6-250Vdc	MP0CAE03
Varistor 24-48Vac/dc	MP0DAE04

Contacts	Code	Contacts	Code
2NO	ECFA220S	4NO	ECFA440S
1NO + 1NC	ECFA211S	3NO + 1NC	ECFA431S
2NC	ECFA202S	2NO + 2NC	ECFA422S
		1NO + 3NC	ECFA413S
		4NC	ECFA404S

Contacts	Code
2NO	BCLL20
1NO + 1NC	BCLL11

Contacts	Code
-	BELA
2NC	BELA02

Setting range (A)	Code
11.5-15 A	RT2A
14.5-19 A	RT2B
18.5-25 A	RT2C
24-32 A	RT2D
30-43 A	RT2E
42-55 A	RT2G
54-65 A	RT2H
64-82 A	RT2J
78-97 A	RT2L
90-110 A	RT2M

Base for separate mounting	RT2XP
----------------------------	-------

Setting range (A)	Code
15-75	RE2H
22-110	RE2M

Base for separate mounting	RE2XP
----------------------------	-------

Setting range (A)	Code Rotary
35 - 50	GPS2BHAT
45 - 63	GPS2BHAU

GPS2 + EF50A-EF80A EFM2AL80	GPS2 EF50E-EF80E EFM2EL80
--------------------------------	------------------------------

Contactors and Overload Relays

CK									
105	150	195	185	250	309	420	550	720	
200	250	250	325	400	500	600	700	1000	
30	45	55	55	75	90	132	160	200	
55	75	110	90	132	160	200	315	400	
90	132	160	160	250	250	400	560	710	
40	50	60	75	75	100	150	200	250	
60	100	125	150	150	250	300	400	500	
75	100	125	150	150	250	300	400	500	
100	125	125	150	150	300	400	500	600	
1x95 16-3/0 AWG	1x120 or 2x95 4/0 AWG	1x120 or 2x95 4/0 AWG	1x240 or 2x150 6 AWG-350kcmil	2(25x5) ⁽¹⁾ 6 AWG - 350kcmil	2(25x5) ⁽¹⁾ 6 AWG - 350kcmil	2(35x5) ⁽¹⁾ 8 AWG - 350 kcmil	2(35x10) ⁽¹⁾ 8 AWG - 500 kcmil	2(35x10) ⁽¹⁾ 2(35x10) ⁽¹⁾	

	CK75CA311 ◆	CK08CA311 ◆						
	CK75CE311 ◆	CK08CE311 ◆		CK09BE311 ◆	CK95BE311 ◆	CK10CE311 ◆	CK11CE311 ◆	CK12BE311 ◆
CK07BA411 ◆			CK08BA411 ◆	CK09BE411 ◆				
CK07BE411 ◆			CK08BE411 ◆	CK09BE411 ◆	CK95BE411 ◆	CK10CE411 ◆	CK11CE411 ◆	CK12BE411 ◆

Replace ◆ by the coil code

Coil voltage AC	Code
110V 50 Hz 120V 60Hz	J
220-230 50/60 Hz 277V 60Hz	N
500-660V 50 Hz 690V 60Hz	Y

Super Wide Coil Voltage AC/DC	Code
24-60V AC/DC -30% +10%	W24-60
48-130V AC/DC -20% +10%	W48-130
100-250V AC/DC -20% +10%	W100-250
250-500V AC/DCv -20% +10%	W250-500

Type	Code
R/C 12-48Vac 50/60 Hz	BSLR3G
R/C 50-127Vac 50/60 Hz	BSLR3K
R/C 130-250Vac 50/60 Hz	BSLR3R
AC/DC 24-500V	built-in

--

Contacts	Code
-	BEKH

<table border="1"> <thead> <tr> <th>Setting range (A)</th> <th>Code</th> </tr> </thead> <tbody> <tr> <td>55-80</td> <td>RT3B</td> </tr> <tr> <td>63-90</td> <td>RT3C</td> </tr> <tr> <td>90-120</td> <td>RT3D</td> </tr> <tr> <td>110-140</td> <td>RT3E</td> </tr> <tr> <td>140-190</td> <td>RT3F</td> </tr> </tbody> </table>	Setting range (A)	Code	55-80	RT3B	63-90	RT3C	90-120	RT3D	110-140	RT3E	140-190	RT3F	<table border="1"> <thead> <tr> <th>Setting range (A)</th> <th>Code</th> </tr> </thead> <tbody> <tr> <td>120-190</td> <td>RT4N</td> </tr> <tr> <td>185-280</td> <td>RT4P</td> </tr> <tr> <td>200-310</td> <td>RT4R</td> </tr> </tbody> </table>	Setting range (A)	Code	120-190	RT4N	185-280	RT4P	200-310	RT4R	<table border="1"> <thead> <tr> <th>Setting range (A)</th> <th>Code</th> </tr> </thead> <tbody> <tr> <td>120-190</td> <td>RT5A</td> </tr> <tr> <td>175-280</td> <td>RT5B</td> </tr> <tr> <td>250-400</td> <td>RT5C</td> </tr> <tr> <td>315-500</td> <td>RT5D</td> </tr> <tr> <td>430-700</td> <td>RT5E</td> </tr> </tbody> </table>	Setting range (A)	Code	120-190	RT5A	175-280	RT5B	250-400	RT5C	315-500	RT5D	430-700	RT5E
Setting range (A)	Code																																	
55-80	RT3B																																	
63-90	RT3C																																	
90-120	RT3D																																	
110-140	RT3E																																	
140-190	RT3F																																	
Setting range (A)	Code																																	
120-190	RT4N																																	
185-280	RT4P																																	
200-310	RT4R																																	
Setting range (A)	Code																																	
120-190	RT5A																																	
175-280	RT5B																																	
250-400	RT5C																																	
315-500	RT5D																																	
430-700	RT5E																																	

Setting range (A)	Code
30-150	RE3E





1 L1

3 L2

5 L3

21 NC

efficor



New

efficor*

Provides Starter and Power Switching Solutions for OEMs and Panel Builders working in the toughest markets such as:

Oil & Gas | Marine | Mining | Power Generation / Grid | Transportation
Industrial appliances | Telecom / Data centers | General industry



Time saving

Quick assembly of DOL Starter

- User friendly design to combine Surion motor starter and contactor
- Smart busbar systems and wiring kits
- Design of intelligent base plate
- Easy maintenance: Complete combination can be removed in one go

No tools needed

- Mounting and dismounting the contactors without tools
- No tools required for accessories and auxiliaries

Double box terminals as standard

- Secure connection: No overheat on small wires when 2 sizes in same terminal
- Identical torque (2.2Nm) for 9A up to 40A contactors



Space saving

Compact starter providing significant space reduction in cabinet:

- Manual motor starter
- OL relay



Stock saving

Significant reduction of 60% in stock keeping units



Energy efficient design

- Low energy consumption
- Long life span
- Reduced flammability risk and lower toxicity



Complete range up to 105A

Contactors

- 3 pole contactors
- 4 pole contactors
- 2NO-2NC contactors
- Auxiliary contactors

Accessories

- Auxiliary contact blocks
- Pneumatic timer
- Mechanical latch
- Surge suppressor

Motor starter solutions

- Thermal and electronic OL relays
- Fuseless starter kits
- Wiring kits for reversing and start-delta
- Parallel busbars



Reliable technology

Designed and manufactured in Europe by GE to perform in the toughest environmental conditions

- Best in class B10d values according to ISO13849-1 safety requirements
- High electrical performance > 1.7 mil. operations
- Safe auxiliary contacts
- Temperature operation without derating: -40°C to +55°C
- AC/DC Super Wide voltage application: Cover all AC and DC range up to 500V with 4 coils
- Coordination type II for motor starter applications

Approvals/Marking



EN50155, EN45545-2
IEC60335



Efficor*

Reliable technology

Best electrical endurance

Long life span; increased uptime resulting in lower maintenance cost.
Higher B10d reliability data: number of safe starting operations as per standard EN ISO 13849-1

ISO 13849 provides safety requirements and guidance principles for the design and integration of safety-related parts of control systems. It specifies characteristics that include the performance level required for carrying out safety functions. B10d is the number of cycles until 10% of the components fails dangerously.

EC09-12	2x10 ⁶ ops
EC18-25	1.7x10 ⁶ ops
EC32-40	1.37x10 ⁶ ops
EF50-105	1.5x10 ⁶ ops

Safe control circuit

- High fidelity auxiliary with four points of contact ensuring conductivity
- Mirror contact according to IEC 60947-4-1
- Positive guided, mechanically linked contacts according to IEC 60947-5-1

Widest temperature operation

From -40°C to +55°C without derating
Suitable for extreme temperatures

Lowest noise production: 32dBA

No humming noise, perfect fit in applications demanding limited noise.

Safer plastics

NF 16-101 & NF 16-102
DIN 5510.2, EN 60355 & EN 45545-2

Only two frames covering 9 up to 105A series.

Five different depths:

- Depth 1: 9A up to 18A
- Depth 2: 25A
- Depth 3: 32A up to 40A
- Depth 4: 50A up to 80A
- Depth 5: 95A up to 105A



Closed design

Offering full protection against pollution

- Transparent front cover for dust protection
- No holes in the base
 - Avoids dust and external particles
 - Enhances the life of the device

- ✓ Ceramic applications
- ✓ Heavy duty environments
- ✓ Environments with high pollution degrees



efficor*

Global contactors

Intro

A

B

C

D

E

F

G

New



Space saving

Compact starter

Significant space reduction in the cabinet: Compact starter either with thermal overload relay or manual motor starter. Starter mounting plates for user-friendly maintenance (easy removal of MMS Surion and/or contactor). Busbar systems and wiring kits allow safe cabling avoiding mistakes, guaranteeing finger safe protection up to 6kV.

Link module for compact starter up to 65A

Link module for compact starter
Full coil access at the bottom

Contactor with thermal overload relay

Uniformity in compact design
Thermal and electronic overload relay mounted directly to the contactor
All connections available

Reduced panel dimensions

- Effcor contactor reduced width design allows designer to reduce panel dimensions or replace old contactors.
- Effcor contactors can be mounted side by side without derating.
- Significant depth reduction in DC contactors.
- Smaller control transformers in AC/DC applications thanks to state of the art electronic coils technology.
- Effcor starting solutions features, dimensions and drawings are available on-line in the most popular panel design software.



Benefits

Intro

A

B

C

D

E

F

G

New



Efficor*

Time saving

Double box terminals

Identical torque (2.2 Nm) from 9 up to 40A.
Only one calibrated screwdriver needed for the runners.
Higher torque from 50 up to 105A.
Efficor contactors have main terminals in the front for easy access.

Easy to use, no tools needed

Mounting or dismounting the contactors on/from the DIN-rail can be done without tools.
Even for mounting accessories and auxiliaries to the contactor, no tools are required.

Quick assembly of direct online starter

- User friendly design of link modules and base plates to combine manual motor starter and contactor.
- Smart busbar systems and wiring kits.
- Smart plate for DOL starters up to 40A.
- 4 coil terminal points for easy design and replacement of old contactors.

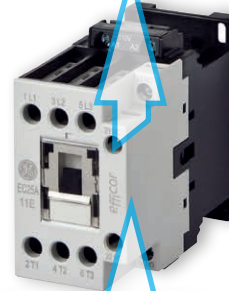
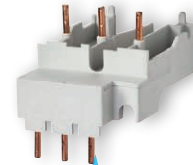
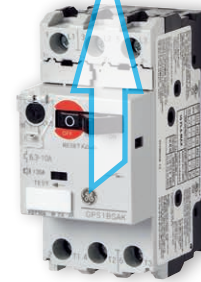

Easy maintenance of direct online starter

- The complete starter combination can be removed from the base plate in one go.

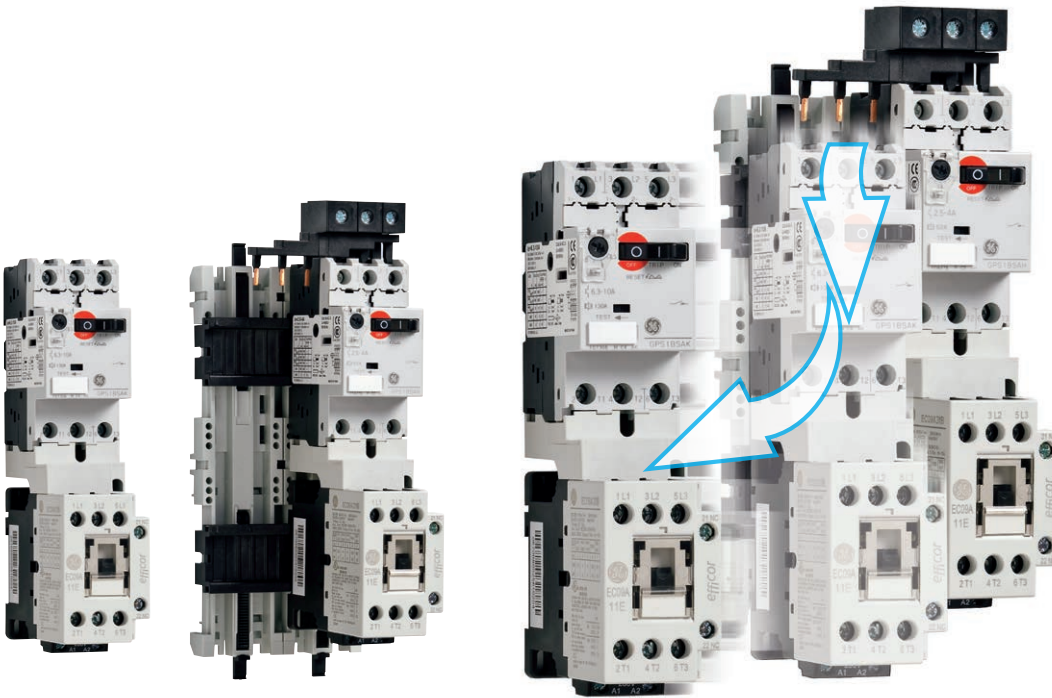

- The manual motor starter and the contactor can be removed separately from the base plate.

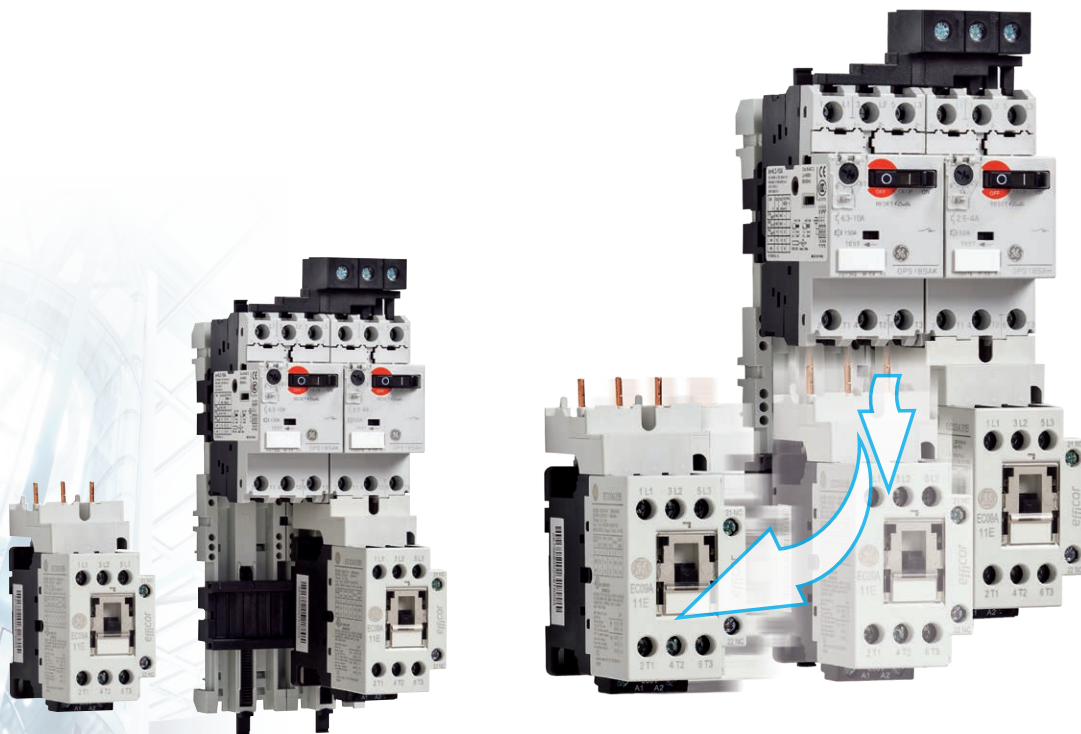

Efficor*

Secure connection

Double box terminals

- Double box clamps for the whole range
 - Cables from 0.75mm² up to 16mm² in the same box clamps terminal for 4kW up to 18.5kW
 - Cables from 1mm² up to 35mm² in the same box clamps terminal for 22kW up to 37kW
 - Cables from 1.5mm² up to 50mm² in the same box clamps terminal for 45kW and 55kW
- No risk of losing cables
- Avoid temperature rising on the small cable

Smart connectivity

- Design of intelligent base plate
- Combination of a wide variety of link modules and wiring kits with the double box clamp terminals secures a safe connection

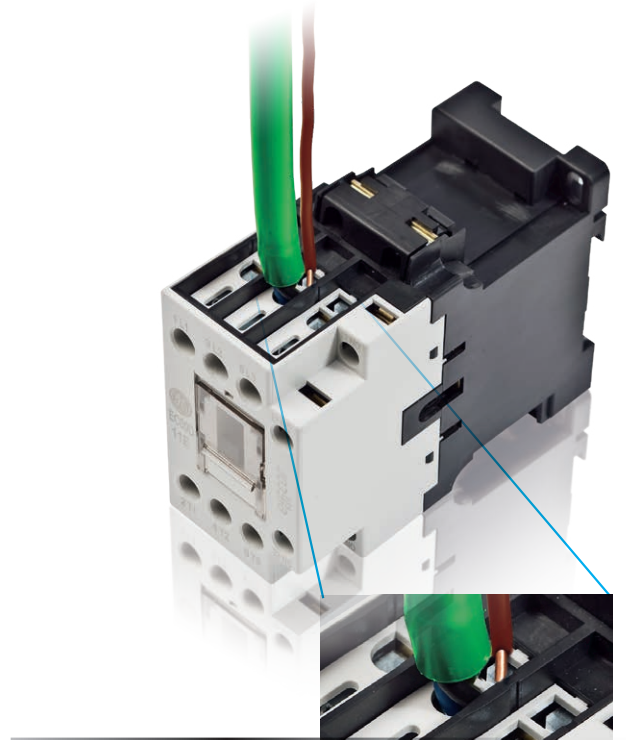
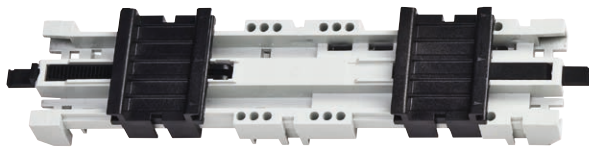

Push the lid in order to move the manual motor starter

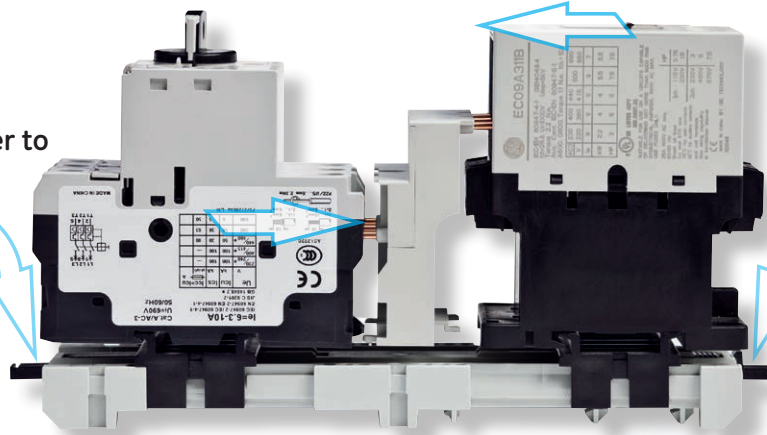

Push the lid in order to move the contactor

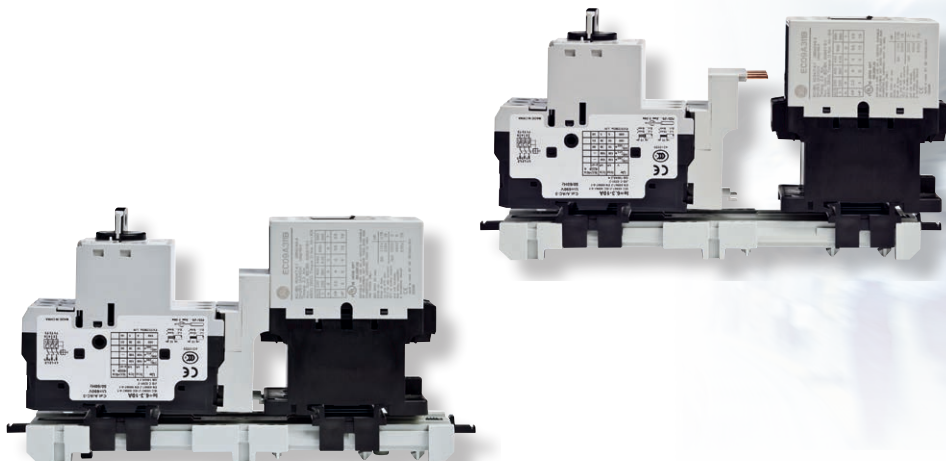

Stock saving

60% reduction in codes

When compared with the current range, the Efficor range means a significant reduction of 60% in stock keeping units. This improves customer financials, simplifying logistics, reducing inventory value and cutting administration costs.

60% reduction in space and volume in warehouses

- 2 built-in auxiliary 3 pole contactors (up to 25A) - reduces customer choices by half - all in 45mm standard width.
- No auxiliary built-in from 32A or 4 poles, customer can choose frontal or lateral without penalizing overall dimensions.
- No need to stock special versions for plastic high performance demanding application because this is included as standard.
- Super wide voltage range electronic module available covering entire AC and DC coil ranges from 24V up to 500V with only 4 coils with voltage suppressor built-in.

Easy identification

Self explanatory description of the catalog number is an important advantage

Example: EC 09 A 3 11 B 0 2 4 ...

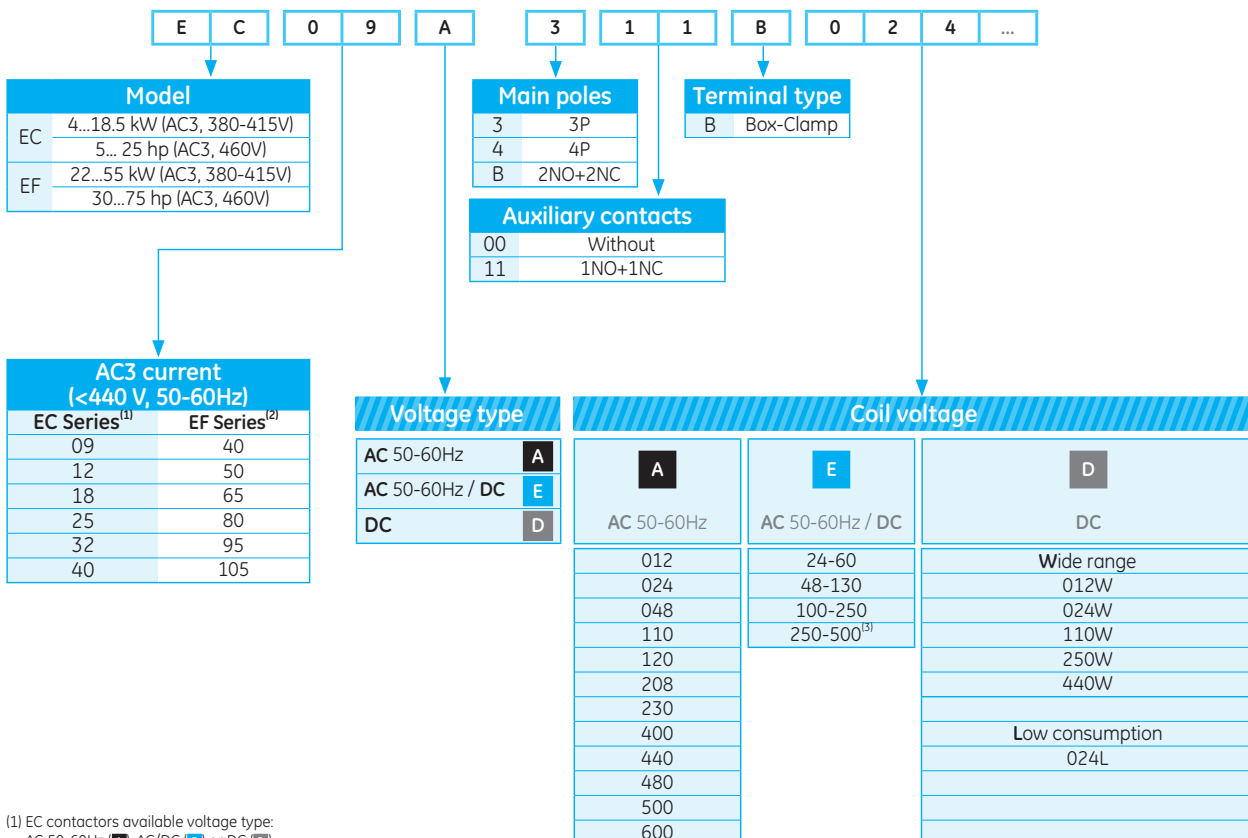

(1) EC contactors available voltage type: AC 50-60Hz (A), AC/DC (E) or DC (D)
 (2) EF contactors available voltage type: AC 50-60Hz (A) or AC/DC (E)
 (3) 250-500 Only available for EF

Benefits

Intro

A

B

C

D

E

F

G

H

I

X



Energy efficiency

Optimized operating with the combination of permanent magnet and electromagnet, spring and coil ensures low energy consumption.

Permanent magnet technology advantages:

- Reduces the energy necessary to keep contactor on hold vs. standard DC coils
- Increases contactor life reducing contact bounce
- There is no peak consumption when contactor is closing
- The contactor is fully open or closed; avoiding intermediate contactor state reduces risk of coil burn and welding contacts

eco-design 

Super wide voltage range electronic coils.

Provides the lowest energy consumption in combination with the widest operation range.

Reduces production shortage and maintenance downtimes with self-protecting software built-in.

- Optimizing logistics with four coils covering 24V up to 500V AC and DC.
- Secure holding operation, super wide voltage range avoids downtimes in weak networks.
- Universal service coil 100-250V AC/DC is suitable for use worldwide replacing more than 10 coils with standard technology (AC: 110, 120, 208, 220, 230, 240V and DC: 110, 125, 220 and 250V)
- Surge suppression always built-in; no need to use additional expensive external surge suppressor... less cost, less worries, simplified design
- Noise free. No humming noise as electronic module always operates coil in optimized condition
- Self-protecting software operates contactor in safe condition avoiding chattering and coil burn. This secures uptime.

Reliable technology
Space saving
Time saving
Secure connection
Stock saving
Energy efficiency



efficor*



Main advantages

Intro

A

B

C

D

E

F

G

H

I

X



Connectivity

- 1 Feeding
- 2 Busbar
- 3 Manual motor starter
- 4 Cover
- 5 Link module
- 6 Contactor
- 7 Base plate

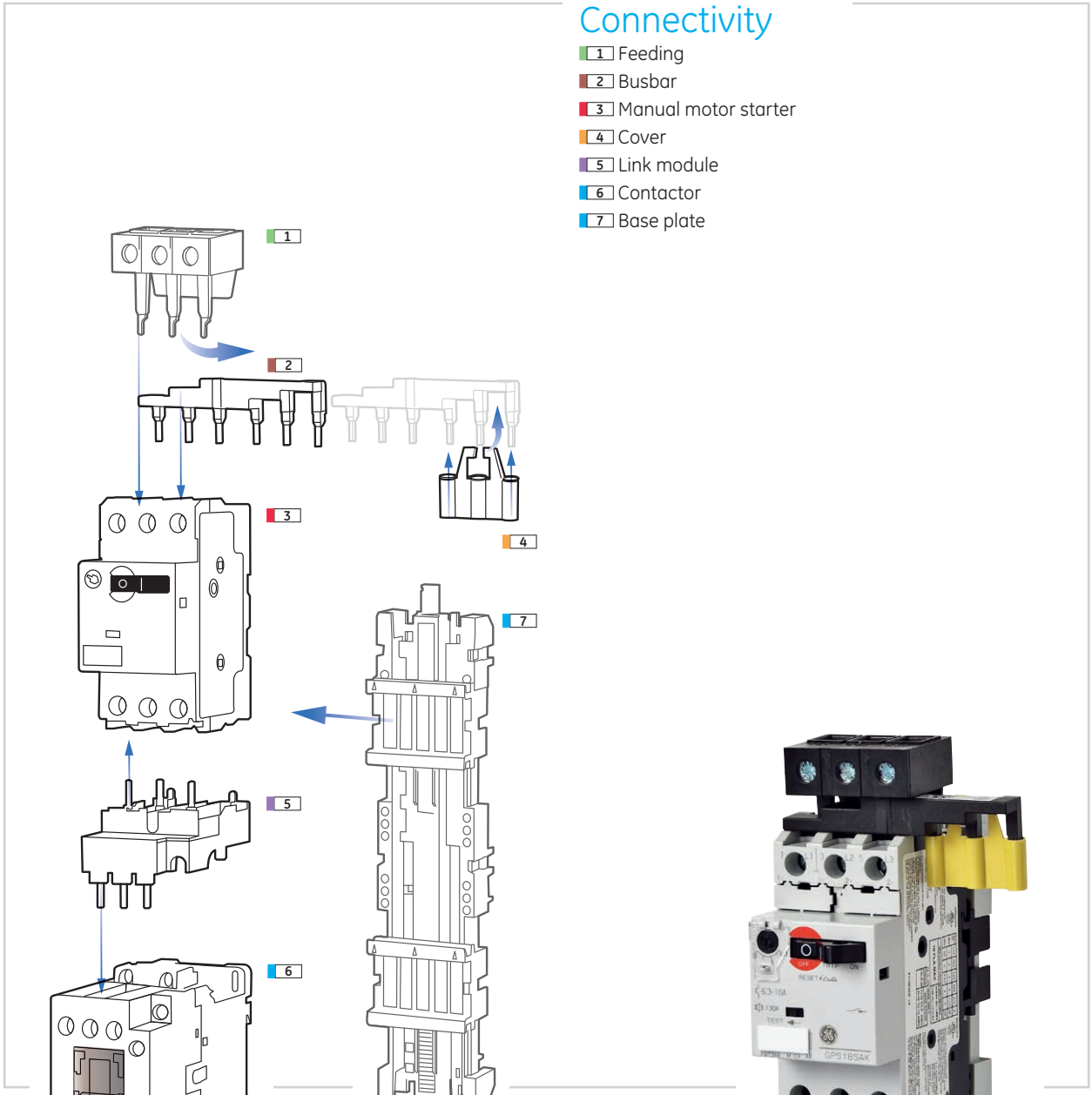

Star delta starter

Connectivity

- 1 Manual motor starter
- 2 Link module
- 3 Wiring kit
- 4 Contactor(s)
- 5 Mechanical interlock
- 6 Timer

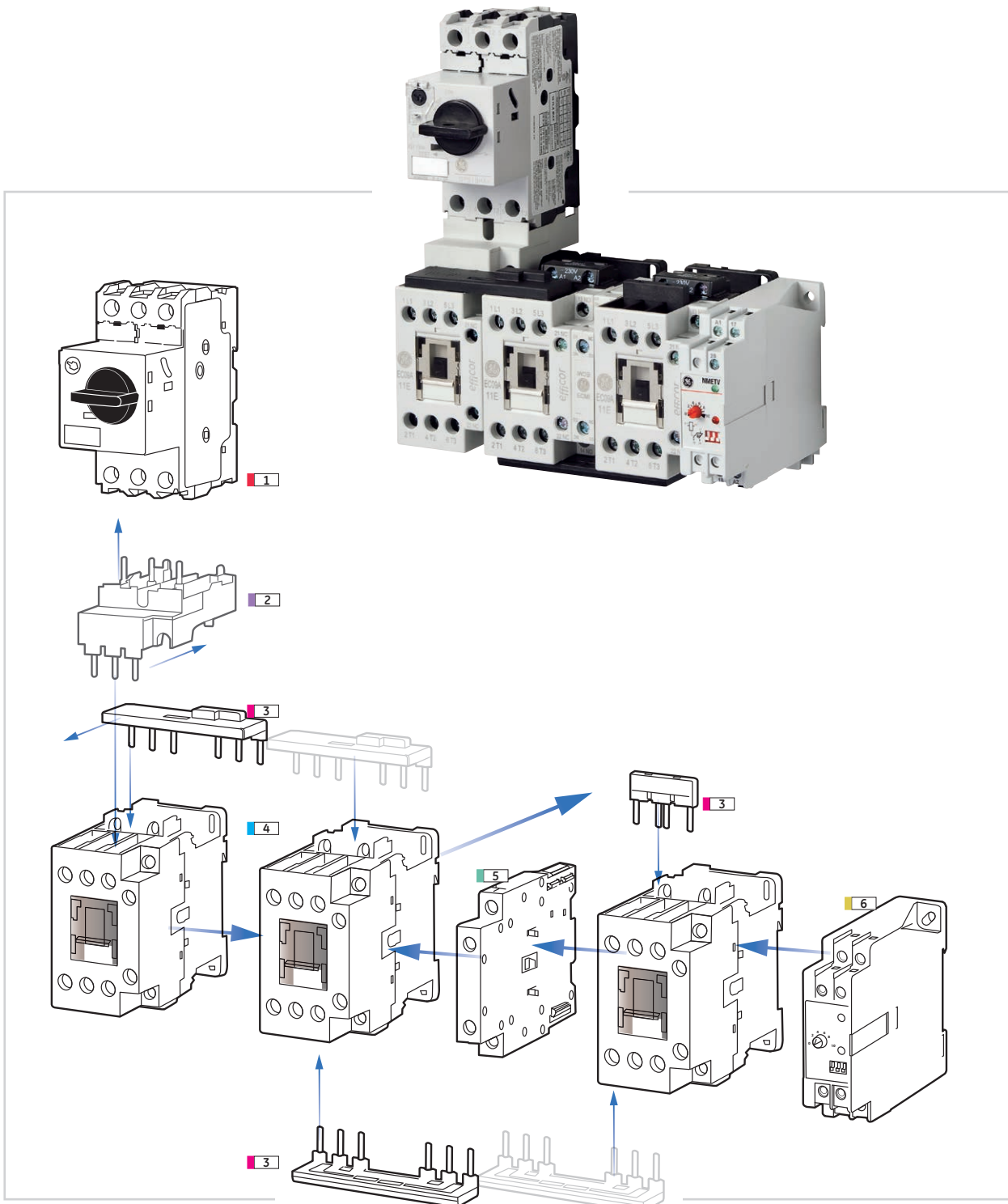

Reversing starter (with thermal overload relay)

Connectivity

- 1 Wiring kit
- 2 Contactor
- 3 Mechanical interlock
- 4 Overload relay

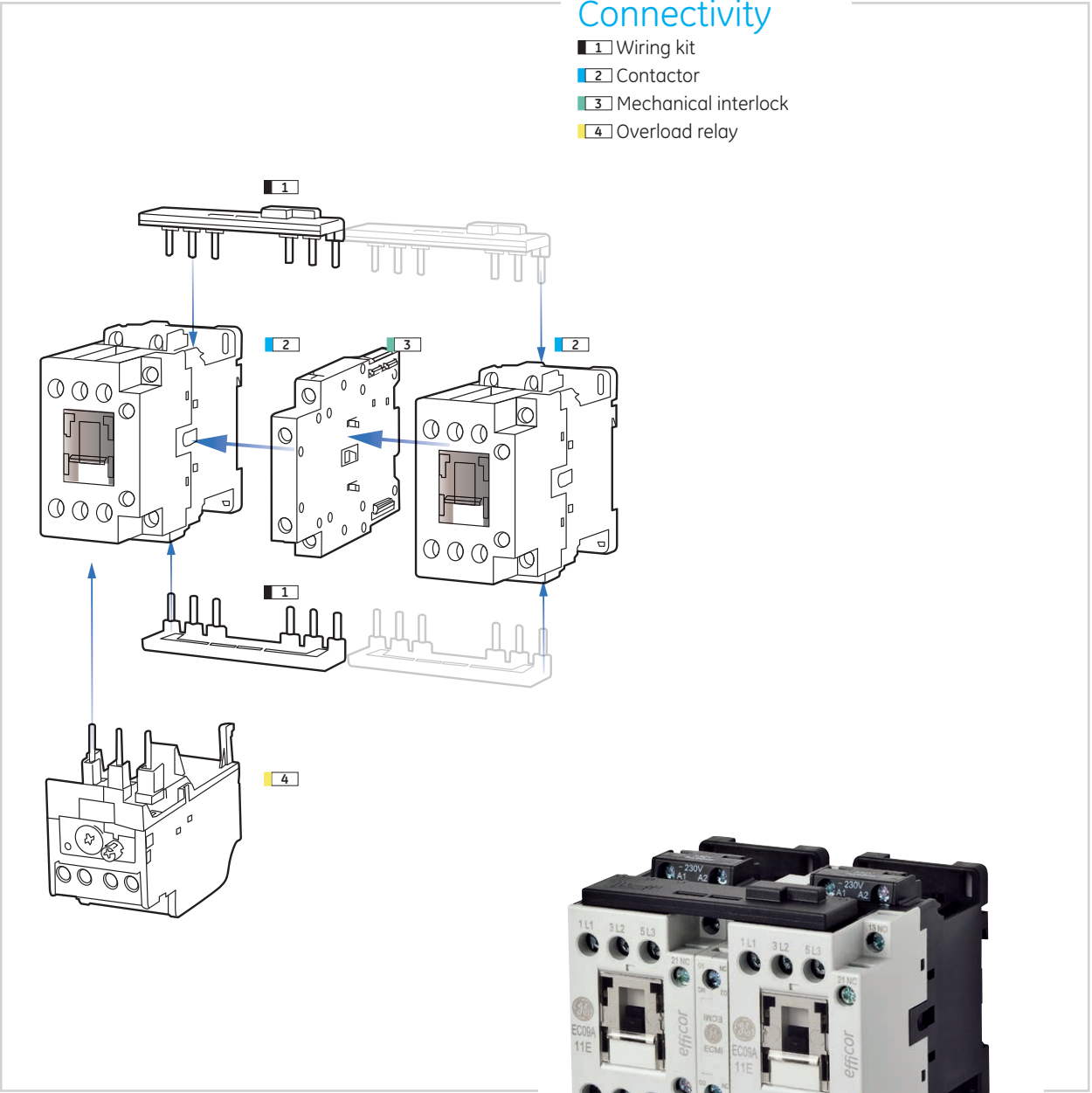

Reversing starter (without thermal overload relay)

Connectivity

- 1 Manual motor starter
- 2 Link module
- 3 Wiring kit
- 4 Contactor
- 5 Mechanical interlock
- 6 Base plate(s)

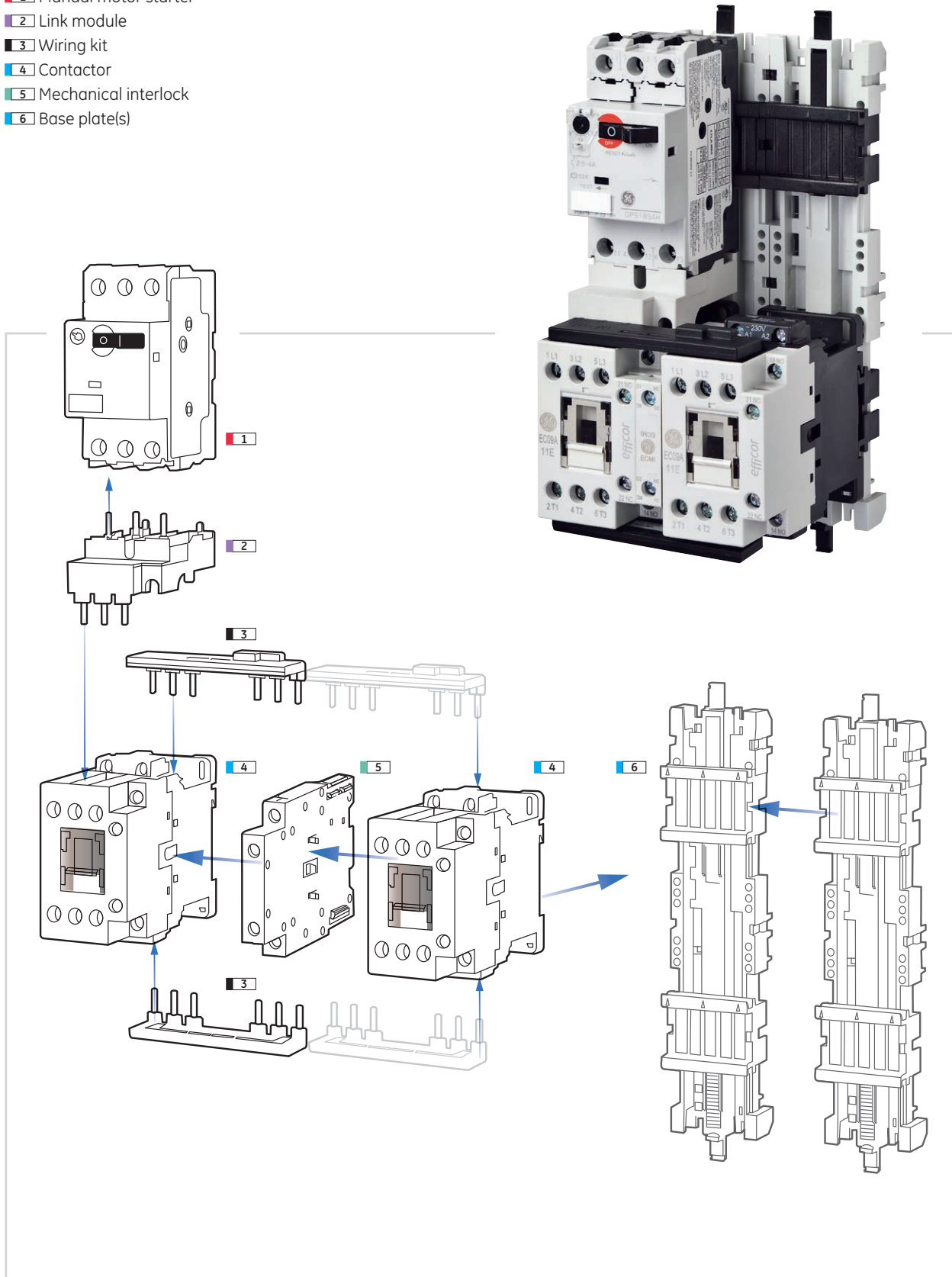

3 pole contactors - Double box terminals

Max. operating current		Admissible power AC3				Electrical endurance	Aux. cont.	Control circuit					
Not inductive load AC1 A	Motors <480V 3Ph 50-60Hz AC3 A	220-240V kW hp	380-415V kW hp	440-480V kW hp	690V kW	Cat. AC3 Operations (B10d)	NO NC	AC			AC		
								Voltage	Cat. no.	Ref. no.	Voltage	Cat. no. ⁽¹⁾	Ref. no.
25	9	2.2 3	4 5.5	4 5.5	7.5	2x10 ⁶		1 1 12	EC09A311B012	267001	AC/DC		
								1 1 24	EC09A311B024	267002	24-60	EC09E311B24-60	216377
								1 1 48	EC09A311B048	267004	48-130	EC09E311B48-130	216378
								1 1 110	EC09A311B110	267005	100-250	EC09E311B100-250	216379
								1 1 120	EC09A311B120	267006	DC		
								1 1 208	EC09A311B208	267007	DC		
								1 1 230	EC09A311B230	267008	12	EC09D311B012W	267085
								1 1 240	EC09A311B240	267009	24	EC09D311B024W	267086
								1 1 400	EC09A311B400	267010	110	EC09D311B110W	267091
								1 1 440	EC09A311B440	267011	250	EC09D311B250W	267094
								1 1 480	EC09A311B480	267012	440	EC09D311B440W	267095
								1 1 500	EC09A311B500	267013	DC		
								1 1 600	EC09A311B600	267014	24	EC09D311B024L	267096
25	12	3 4	5.5 7.5	5.5 7.5	11	2x10 ⁶		1 1 12	EC12A311B012	267015	AC/DC		
								1 1 24	EC12A311B024	267016	24-60	EC12E311B24-60	216380
								1 1 48	EC12A311B048	267018	48-130	EC12E311B48-130	216381
								1 1 110	EC12A311B110	267019	100-250	EC12E311B100-250	216382
								1 1 120	EC12A311B120	267020	DC		
								1 1 208	EC12A311B208	267021	DC		
								1 1 230	EC12A311B230	267022	12	EC12D311B012W	267100
								1 1 240	EC12A311B240	267023	24	EC12D311B024W	267101
								1 1 400	EC12A311B400	267024	110	EC12D311B110W	267106
								1 1 440	EC12A311B440	267025	250	EC12D311B250W	267109
								1 1 480	EC12A311B480	267026	440	EC12D311B440W	267110
								1 1 500	EC12A311B500	267027	DC		
								1 1 600	EC12A311B600	267028	24	EC12D311B024L	267111
32	18	4 5.5	7.5 10	7.5 10	15	1.7x10 ⁶		1 1 12	EC18A311B012	267029	AC/DC		
								1 1 24	EC18A311B024	267030	24-60	EC18E311B24-60	216383
								1 1 48	EC18A311B048	267032	48-130	EC18E311B48-130	216384
								1 1 110	EC18A311B110	267033	100-250	EC18E311B100-250	216385
								1 1 120	EC18A311B120	267034	DC		
								1 1 208	EC18A311B208	267035	DC		
								1 1 230	EC18A311B230	267036	12	EC18D311B012W	267115
								1 1 240	EC18A311B240	267037	24	EC18D311B024W	267116
								1 1 400	EC18A311B400	267038	110	EC18D311B110W	267121
								1 1 440	EC18A311B440	267039	250	EC18D311B250W	267124
								1 1 480	EC18A311B480	267040	440	EC18D311B440W	267125
								1 1 500	EC18A311B500	267041	DC		
								1 1 600	EC18A311B600	267042	24	EC18D311B024L	267126
45	25	7.5 10	11 15	12 16	22	1.7x10 ⁶		1 1 12	EC25A311B012	267043	AC/DC		
								1 1 24	EC25A311B024	267044	24-60	EC25E311B24-60	216386
								1 1 48	EC25A311B048	267046	48-130	EC25E311B48-130	216387
								1 1 110	EC25A311B110	267047	100-250	EC25E311B100-250	216388
								1 1 120	EC25A311B120	267048	DC		
								1 1 208	EC25A311B208	267049	DC		
								1 1 230	EC25A311B230	267050	12	EC25D311B012W	267130
								1 1 240	EC25A311B240	267051	24	EC25D311B024W	267131
								1 1 400	EC25A311B400	267052	110	EC25D311B110W	267136
								1 1 440	EC25A311B440	267053	250	EC25D311B250W	267139
								1 1 480	EC25A311B480	267054	440	EC25D311B440W	267140
								1 1 500	EC25A311B500	267055	DC		
								1 1 600	EC25A311B600	267056	24	EC25D311B024L	267141
60	32	9 12	15 22	15 22	30	1.37x10 ⁶		0 0 12	EC32A300B012	267057	AC/DC		
								0 0 24	EC32A300B024	267058	24-60	EC32E300B24-60	216389
								0 0 48	EC32A300B048	267060	48-130	EC32E300B48-130	216390
								0 0 110	EC32A300B110	267061	100-250	EC32E300B100-250	216391
								0 0 120	EC32A300B120	267062	DC		
								0 0 208	EC32A300B208	267063	DC		
								0 0 230	EC32A300B230	267064	12	EC32D300B012W	267145
								0 0 240	EC32A300B240	267065	24	EC32D300B024W	267146
								0 0 400	EC32A300B400	267066	110	EC32D300B110W	267151
								0 0 440	EC32A300B440	267067	250	EC32D300B250W	267154
								0 0 480	EC32A300B480	267068	440	EC32D300B440W	267155
								0 0 500	EC32A300B500	267069	DC		
								0 0 600	EC32A300B600	267070	24	EC32D300B024L	267156
60	40	11 15	18.5 25	22 30	37	1.37x10 ⁶		0 0 12	EC40A300B012	267071	AC/DC		
								0 0 24	EC40A300B024	267072	24-60	EC40E300B24-60	216392
								0 0 48	EC40A300B048	267074	48-130	EC40E300B48-130	216393
								0 0 110	EC40A300B110	267075	100-250	EC40E300B100-250	216394
								0 0 120	EC40A300B120	267076	DC		
								0 0 208	EC40A300B208	267077	DC		
								0 0 230	EC40A300B230	267078	12	EC40D300B012W	267160
								0 0 240	EC40A300B240	267079	24	EC40D300B024W	267161
								0 0 400	EC40A300B400	267080	110	EC40D300B110W	267166
								0 0 440	EC40A300B440	267081	250	EC40D300B250W	267169
								0 0 480	EC40A300B480	267082	440	EC40D300B440W	267170
								0 0 500	EC40A300B500	267083	DC		
								0 0 600	EC40A300B600	267084	24	EC40D300B024L	267171



(1) End character: W = Wide voltage (0.7-1.25xUn) and built-in diode.
L = Low consumption.



3 pole contactors - Double box terminals

Max. operating current		Admissible power AC3				Electrical endurance	Aux. cont.	Control circuit								
Not inductive load AC1 A	Motors <480V 3Ph 50-60Hz AC3 A	220-240V kW hp	380-415V kW hp	440-480V kW hp	690V kW	Cat. AC3 Operations (B10d)	NO	NC	AC			AC/DC			Pack	
									Voltage ⁽¹⁾	Cat. no.	Ref. no.	Voltage	Cat. no.	Ref. no.		
90	50	11 15	22 30	22 30	35	1.5x10 ⁶	0	0	12	EF50A300B012	270000					1
							0	0	24	EF50A300B024	270001	24-60	EF50E300B24-60	270074	1	
							0	0	48	EF50A300B048	270003					1
		0	0	110	EF50A300B110		270004	48-130	EF50E300B48-130	270075	1					
		0	0	208	EF50A300B208		270007					1				
		0	0	230	EF50A300B230		270008	100-250	EF50E300B100-250	270076	1					
		0	0	400	EF50A300B400		270009	250-500	EF50E300B250-500	270078	1					
		0	0	480	EF50A300B480		270011					1				
		0	0	600	EF50A300B600		270014					1				
110	65	18.5 25	30 40	37 50	45	1.5x10 ⁶	0	0	12	EF65A300B012	270015					1
							0	0	24	EF65A300B024	270016	24-60	EF65E300B24-60	270079	1	
							0	0	48	EF65A300B048	270018					1
		0	0	110	EF65A300B110		270019	48-130	EF65E300B48-130	270080	1					
		0	0	208	EF65A300B208		270021					1				
		0	0	230	EF65A300B230		270022	100-250	EF65E300B100-250	270081	1					
		0	0	400	EF65A300B400		270023	250-500	EF65E300B250-500	270082	1					
		0	0	480	EF65A300B480		270025					1				
		0	0	600	EF65A300B600		270028					1				
110	80	22 30	37 50	37 60	45	1.5x10 ⁶	0	0	12	EF80A300B012	270029					1
							0	0	24	EF80A300B024	270030	24-60	EF80E300B24-60	270083	1	
							0	0	48	EF80A300B048	270032					1
		0	0	110	EF80A300B110		270033	48-130	EF80E300B48-130	270084	1					
		0	0	208	EF80A300B208		270035					1				
		0	0	230	EF80A300B230		270036	100-250	EF80E300B100-250	270085	1					
		0	0	400	EF80A300B400		270037	250-500	EF80E300B250-500	270086	1					
		0	0	480	EF80A300B480		270039					1				
		0	0	600	EF80A300B600		270042					1				
140	95	25 34	45 60	55 75	55	1.5x10 ⁶	0	0	12	EF95A300B012	270043					1
							0	0	24	EF95A300B024	270044	24-60	EF95E300B24-60	270087	1	
							0	0	48	EF95A300B048	270046					1
		0	0	110	EF95A300B110		270047	48-130	EF95E300B48-130	270088	1					
		0	0	208	EF95A300B208		270049					1				
		0	0	230	EF95A300B230		270050	100-250	EF95E300B100-250	270089	1					
		0	0	400	EF95A300B400		270052	250-500	EF95E300B250-500	270090	1					
		0	0	480	EF95A300B480		270054					1				
		0	0	600	EF95A300B600		270057					1				
140	105	30 40	55 75	55 75	65	1.5x10 ⁶	0	0	12	EF105A300B012	270058					1
							0	0	24	EF105A300B024	270059	24-60	EF105E300B24-60	270091	1	
							0	0	48	EF105A300B048	270061					1
		0	0	110	EF105A300B110		270062	48-130	EF105E300B48-130	270092	1					
		0	0	208	EF105A300B208		270064					1				
		0	0	230	EF105A300B230		270065	100-250	EF105E300B100-250	270093	1					
		0	0	400	EF105A300B400		270066	250-500	EF105E300B250-500	270094	1					
		0	0	480	EF105A300B480		270070					1				
		0	0	600	EF105A300B600		270073					1				

(1) Voltage 110V covers 110V 50-60Hz and 120V 60Hz.



Order codes
Intro
A
B
C
D
E
F
G
H
I
X

4 pole contactors - Double box terminals

Global contactors

Intro

A

B

C

D

E

F

G

H

I

X

Max. operating current		Admissible power AC1				Electrical endurance	Power cont.	Control circuit						
Not inductive load AC1 A	Motors <480V 3Ph 50-60Hz AC3 A	220-240V kW	380-415V kW	440-480V kW	690V kW	Cat. AC3 Operations (B10d)	NO	NC	AC			DC		
									Voltage	Cat. no.	Ref. no.	Voltage	Cat. no. ⁽¹⁾	Ref. no.
25	12	9.5	16.5	19	30	4x10 ⁵	4	0	12	EC12A400B012	267175	AC/DC		
									24	EC12A400B024	267176	24-60	EC12E400B24-60	216395
									48	EC12A400B048	267178	48-130	EC12E400B48-130	216396
									110	EC12A400B110	267179	100-250	EC12E400B100-250	216397
									120	EC12A400B120	267180	DC		
									208	EC12A400B208	267181	DC		
									230	EC12A400B230	267182	12	EC12D400B012W	267231
									240	EC12A400B240	267183	24	EC12D400B024W	267232
									400	EC12A400B400	267184	110	EC12D400B110W	267237
									440	EC12A400B440	267185	250	EC12D400B250W	267240
									480	EC12A400B480	267186	440	EC12D400B440W	267241
									500	EC12A400B500	267187	DC		
									600	EC12A400B600	267188	24	EC12D400B024L	267242
32	18	12	22	24	38	6x10 ⁵	4	0	12	EC18A400B012	267189	AC/DC		
									24	EC18A400B024	267190	24-60	EC18E400B24-60	216398
									48	EC18A400B048	267192	48-130	EC18E400B48-130	216399
									110	EC18A400B110	267193	100-250	EC18E400B100-250	216400
									120	EC18A400B120	267194	DC		
									208	EC18A400B208	267195	DC		
									230	EC18A400B230	267196	12	EC18D400B012W	267246
									240	EC18A400B240	267197	24	EC18D400B024W	267247
									400	EC18A400B400	267198	110	EC18D400B110W	267252
									440	EC18A400B440	267199	250	EC18D400B250W	267255
									480	EC18A400B480	267200	440	EC18D400B440W	267256
									500	EC18A400B500	267201	DC		
									600	EC18A400B600	267202	24	EC18D400B024L	267257
45	25	17	29	34	54	6.5x10 ⁵	4	0	12	EC25A400B012	267203	AC/DC		
									24	EC25A400B024	267204	24-60	EC25E400B24-60	216401
									48	EC25A400B048	267206	48-130	EC25E400B48-130	216402
									110	EC25A400B110	267207	100-250	EC25E400B100-250	216403
									120	EC25A400B120	267208	DC		
									208	EC25A400B208	267209	DC		
									230	EC25A400B230	267210	12	EC25D400B012W	267261
									240	EC25A400B240	267211	24	EC25D400B024W	267262
									400	EC25A400B400	267212	110	EC25D400B110W	267267
									440	EC25A400B440	267213	250	EC25D400B250W	267270
									480	EC25A400B480	267214	440	EC25D400B440W	267271
									500	EC25A400B500	267215	DC		
									575	EC25A400B575	269083	24	EC25D400B024L	267272
60	32	22.5	39.5	46	72	8x10 ⁵	4	0	12	EC32A400B012	267217	AC/DC		
									24	EC32A400B024	267218	24-60	EC32E400B24-60	216404
									48	EC32A400B048	267220	48-130	EC32E400B48-130	216405
									110	EC32A400B110	267221	100-250	EC32E400B100-250	216406
									120	EC32A400B120	267222	DC		
									208	EC32A400B208	267223	DC		
									230	EC32A400B230	267224	12	EC32D400B012W	267276
									240	EC32A400B240	267225	24	EC32D400B024W	267277
									400	EC32A400B400	267226	110	EC32D400B110W	267282
									440	EC32A400B440	267227	250	EC32D400B250W	267285
									480	EC32A400B480	267228	440	EC32D400B440W	267286
									500	EC32A400B500	267229	DC		
									600	EC32A400B600	267230	24	EC32D400B024L	267287



(1) End character: W = Wide voltage (0.7-1.25xUn) and built-in diode.
L = Low consumption.



4 pole contactors - Double box terminals

Max. operating current		Admissible power AC1				Electrical endurance	Power cont.	Control circuit								
Not inductive load AC1 A	Motors <480V 3Ph 50-60Hz AC3 A	220-240V kW	380-415V kW	440-480V kW	690V kW	Cat. AC3 Operations (B10d)	NO	NC	AC			AC/DC			Pack	
									Voltage ⁽¹⁾	Cat. no.	Ref. no.	Voltage	Cat. no.	Ref. no.		
90	50	34	55	60	95	1.5x10 ⁶	4	0	12	EF50A400B012	270095					1
							4	0	24	EF50A400B024	270096	24-60	EF50E400B24-60	270137		1
							4	0	48	EF50A400B048	270098					1
							4	0	110	EF50A400B110	270100	48-130	EF50E400B48-130	270138		1
							4	0	208	EF50A400B208	270101					1
							4	0	230	EF50A400B230	270102	100-250	EF50E400B100-250	270139		1
							4	0	400	EF50A400B400	270103	250-500	EF50E400B250-500	270140		1
							4	0	480	EF50A400B480	270105					1
							4	0	600	EF50A400B600	270108					1
110	65	42	72.5	85	125	1.5x10 ⁶	4	0	12	EF80A400B012	270109					1
							4	0	24	EF80A400B024	270110	24-60	EF80E400B24-60	270141		1
							4	0	48	EF80A400B048	270112					1
							4	0	110	EF80A400B110	270114	48-130	EF80E400B48-130	270142		1
							4	0	208	EF80A400B208	270115					1
							4	0	230	EF80A400B230	270116	100-250	EF80E400B100-250	270143		1
							4	0	400	EF80A400B400	270117	250-500	EF80E400B250-500	270144		1
							4	0	480	EF80A400B480	270119					1
							4	0	600	EF80A400B600	270122					1
140	95	53	92	105	160	1.5x10 ⁶	4	0	12	EF95A400B012	270123					1
							4	0	24	EF95A400B024	270124	24-60	EF95E400B24-60	270145		1
							4	0	48	EF95A400B048	270126					1
							4	0	110	EF95A400B110	270128	48-130	EF95E400B48-130	270146		1
							4	0	208	EF95A400B208	270129					1
							4	0	230	EF95A400B230	270130	100-250	EF95E400B100-250	270147		1
							4	0	400	EF95A400B400	270131	250-500	EF95E400B250-500	270148		1
							4	0	480	EF95A400B480	270133					1
							4	0	600	EF95A400B600	270136					1



(1) Voltage 110V covers 110V 50-60Hz and 120V 60Hz.

Order codes

Intro

A

B

C

D

E

F

G

H

I

X



2NO - 2NC contactors - Double box terminals

Global contactors

Max. operating current		Admissible power AC3				Electrical endurance	Power cont.	Control circuit						
Not inductive load AC1 A	Motors <480V 3Ph 50-60Hz AC3 A	220-240V	380-415V	440-480V	690V	Cat. AC3 Operations (B10d)	NO	NC	AC			DC		
		kW hp	kW hp	kW hp	kW				Voltage	Cat. no.	Ref. no.	Voltage	Cat. no. ⁽¹⁾	Ref. no.
25	12	3 4	5.5 7.5	5.5 7.5	7.5	2x10 ⁶	2	2	12	EC12AB00B012	267291	AC/DC		
									24	EC12AB00B024	267292	24-60	EC12EB00B24-60	216407
		48	EC12AB00B048	267294	48-130				EC12EB00B48-130	216408				
		110	EC12AB00B110	267295	100-250				EC12EB00B100-250	216409				
		120	EC12AB00B120	267296	DC									
		208	EC12AB00B208	267297	DC									
		230	EC12AB00B230	267298	12				EC12DB00B012W	267347				
		240	EC12AB00B240	267299	24				EC12DB00B024W	267348				
		400	EC12AB00B400	267300	110				EC12DB00B110W	267353				
		440	EC12AB00B440	267301	250				EC12DB00B250W	267356				
		480	EC12AB00B480	267302	440				EC12DB00B440W	267357				
		500	EC12AB00B500	267303	DC									
		600	EC12AB00B600	267304	24				EC12DB00B024L	267358				
		32	18	4 5.5	7.5 10				7.5 10	15	1.7x10 ⁶	2	2	12
24	EC18AB00B024					267306	24-60	EC18EB00B24-60						216410
48	EC18AB00B048			267308	48-130	EC18EB00B48-130	216411							
110	EC18AB00B110			267309	100-250	EC18EB00B100-250	216412							
120	EC18AB00B120			267310	DC									
208	EC18AB00B208			267311	DC									
230	EC18AB00B230			267312	12	EC18DB00B012W	267362							
240	EC18AB00B240			267313	24	EC18DB00B024W	267363							
400	EC18AB00B400			267314	110	EC18DB00B110W	267368							
440	EC18AB00B440			267315	250	EC18DB00B250W	267371							
480	EC18AB00B480			267316	440	EC18DB00B440W	267372							
500	EC18AB00B500			267317	DC									
600	EC18AB00B600			267318	24	EC18DB00B024L	267373							
45	25			7.5 10	11 15	12 16	22	1.7x10 ⁶	2	2				12
		24	EC25AB00B024								267320	24-60	EC25EB00B24-60	216413
		48	EC25AB00B048	267322	48-130	EC25EB00B48-130	216414							
		110	EC25AB00B110	267323	100-250	EC25EB00B100-250	216415							
		120	EC25AB00B120	267324	DC									
		208	EC25AB00B208	267325	DC									
		230	EC25AB00B230	267326	12	EC25DB00B012W	267377							
		240	EC25AB00B240	267327	24	EC25DB00B024W	267378							
		400	EC25AB00B400	267328	110	EC25DB00B110W	267383							
		440	EC25AB00B440	267329	250	EC25DB00B250W	267386							
		480	EC25AB00B480	267330	440	EC25DB00B440W	267387							
		500	EC25AB00B500	267331	DC									
		600	EC25AB00B600	267332	DC									
		60	32	9 12	15 22	15 22	30				1.37x10 ⁶	2	2	12
24	EC32AB00B024							267334	24-60	EC32EB00B24-60				216416
48	EC32AB00B048			267336	48-130	EC32EB00B48-130	216417							
110	EC32AB00B110			267337	100-250	EC32EB00B100-250	216418							
120	EC32AB00B120			267338	DC									
208	EC32AB00B208			267339	DC									
230	EC32AB00B230			267340	12	EC32DB00B012W	267392							
240	EC32AB00B240			267341	24	EC32DB00B024W	267393							
400	EC32AB00B400			267342	110	EC32DB00B110W	267398							
440	EC32AB00B440			267343	250	EC32DB00B250W	267401							
480	EC32AB00B480			267344	440	EC32DB00B440W	267402							
500	EC32AB00B500			267345	DC									
600	EC32AB00B600			267346	DC									



(1) End character: W = Wide voltage (0.7-1.25xUn) and built-in diode.
L = Low consumption.



2NO - 2NC contactors - Double box terminals

Max. operating current		Admissible power AC3				Electrical endurance	Power cont.	Control circuit								
Not inductive load AC1 A	Motors <480V 3Ph 50-60Hz AC3 A	220-240V kW hp	380-415V kW hp	440-480V kW hp	690V kW	Cat. AC3 Operations (B10d)	NO	NC	AC			AC/DC			Pack	
									Voltage ⁽¹⁾	Cat. no.	Ref. no.	Voltage	Cat. no.	Ref. no.		
90	40	11 15	18.5 20	22 30	22	1.5x10 ⁶	2	2	12	EF40AB00B012	270149					1
							2	2	24	EF40AB00B024	270150	24-60	EF40EB00B24-60	270191		1
							2	2	48	EF40AB00B048	270152					1
							2	2	110	EF40AB00B110	270154	48-130	EF40EB00B48-130	270192		1
							2	2	208	EF40AB00B208	270155					1
							2	2	230	EF40AB00B230	270156	100-250	EF40EB00B100-250	270193		1
							2	2	400	EF40AB00B400	270157	250-500	EF40EB00B250-500	270194		1
							2	2	480	EF40AB00B480	270159					1
							2	2	600	EF40AB00B600	270162					1
110	65	18.5 20	22 30	37 50	37	1.5x10 ⁶	2	2	12	EF65AB00B012	270163					1
							2	2	24	EF65AB00B024	270164	24-60	EF65EB00B24-60	270195		1
							2	2	48	EF65AB00B048	270166					1
							2	2	110	EF65AB00B110	270168	48-130	EF65EB00B48-130	270196		1
							2	2	208	EF65AB00B208	270169					1
							2	2	230	EF65AB00B230	270170	100-250	EF65EB00B100-250	270197		1
							2	2	400	EF65AB00B400	270171	250-500	EF65EB00B250-500	270198		1
							2	2	480	EF65AB00B480	270173					1
							2	2	600	EF65AB00B600	270176					1
110	80	22 30	37 40	37 60	37	1.5x10 ⁶	2	2	12	EF80AB00B012	270177					1
							2	2	24	EF80AB00B024	270178	24-60	EF80EB00B24-60	270200		1
							2	2	48	EF80AB00B048	270180					1
							2	2	110	EF80AB00B110	270182	48-130	EF80EB00B48-130	270201		1
							2	2	208	EF80AB00B208	270183					1
							2	2	230	EF80AB00B230	270184	100-250	EF80EB00B100-250	270202		1
							2	2	400	EF80AB00B400	270185	250-500	EF80EB00B250-500	270203		1
							2	2	480	EF80AB00B480	270187					1
							2	2	600	EF80AB00B600	270190					1

(1) Voltage 110V covers 110V 50-60Hz and 120V 60Hz.



Order codes

Intro

A

B

C

D

E

F

G

H

I

X



Voltage type		Coil voltage		
AC 50-60Hz	A	A AC 50-60Hz	E AC 50-60Hz / DC	D DC
AC 50-60Hz / DC	E			
DC	D			
		012	24-60	Wide range
		024	48-130	012W
		048	100-250	024W
		110	250-500 ⁽¹⁾	110W
		120		250W
		208		440W
		230		
		400		Low consumption
		440		024L
		480		
		500		
		600		

Spare coils for contactors and auxiliary contactors - Box clamp terminals

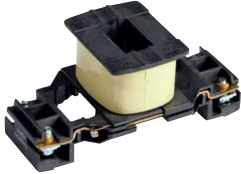
	Voltage	Use for	Cat. no.	Ref. no.	Pack
	12V AC	EC09A...EC18A, ECACA...B	ECCS1A012S	268687	5
	24V AC	EC09A...EC18A, ECACA...B	ECCS1A024S	268688	5
	48V AC	EC09A...EC18A, ECACA...B	ECCS1A048S	268690	5
	110V AC	EC09A...EC18A, ECACA...B	ECCS1A110S	268691	5
	120V AC	EC09A...EC18A, ECACA...B	ECCS1A120S	268692	5
	208V AC	EC09A...EC18A, ECACA...B	ECCS1A208S	268693	5
	230V AC	EC09A...EC18A, ECACA...B	ECCS1A230S	268694	5
	240V AC	EC09A...EC18A, ECACA...B	ECCS1A240S	268695	5
	400V AC	EC09A...EC18A, ECACA...B	ECCS1A400S	268696	5
	440V AC	EC09A...EC18A, ECACA...B	ECCS1A440S	268697	5
	480V AC	EC09A...EC18A, ECACA...B	ECCS1A480S	268698	5
	500V AC	EC09A...EC18A, ECACA...B	ECCS1A500S	268699	5
	575V AC	EC09A...EC18A, ECACA...B	ECCS1A575S	268984	5
	600V AC	EC09A...EC18A, ECACA...B	ECCS1A600S	268700	5
	12V AC	EC25A...EC40A...B	ECCS2A012S	268716	5
	24V AC	EC25A...EC40A...B	ECCS2A024S	268717	5
	48V AC	EC25A...EC40A...B	ECCS2A048S	268719	5
	110V AC	EC25A...EC40A...B	ECCS2A110S	268720	5
	120V AC	EC25A...EC40A...B	ECCS2A120S	268721	5
	208V AC	EC25A...EC40A...B	ECCS2A208S	268722	5
	230V AC	EC25A...EC40A...B	ECCS2A230S	268723	5
	240V AC	EC25A...EC40A...B	ECCS2A240S	268724	5
	400V AC	EC25A...EC40A...B	ECCS2A400S	268725	5
	440V AC	EC25A...EC40A...B	ECCS2A440S	268726	5
	480V AC	EC25A...EC40A...B	ECCS2A480S	268727	5
	500V AC	EC25A...EC40A...B	ECCS2A500S	268728	5
	575V AC	EC25A...EC40A...B	ECCS2A575S	268985	5
	600V AC	EC25A...EC40A...B	ECCS2A600S	268729	5
	12V AC	EF40A...EF105A	EFCSA012S	255020	1
	24V AC	EF40A...EF105A	EFCSA024S	255021	1
	48V AC	EF40A...EF105A	EFCSA048S	255022	1
	110V AC ⁽¹⁾	EF40A...EF105A	EFCSA110S	255023	1
	208V AC	EF40A...EF105A	EFCSA208S	255025	1
	230V AC	EF40A...EF105A	EFCSA230S	255026	1
	400V AC	EF40A...EF105A	EFCSA400S	255027	1
	480V AC	EF40A...EF105A	EFCSA480S	255028	1
	575V AC	EF40A...EF105A	EFCSA575S	255029	1
	600V AC	EF40A...EF105A	EFCSA600S	255030	1

(1) Voltage 110V AC covers 110V 50-60Hz and 120V 60Hz.



Accessories for contactors

Auxiliary contact blocks

	Contacts				Box clamp terminals		Pack
	NO	NC	NO EM	NC EM	Cat. no.	Ref. no.	
	•3 •4	•1 •2	•7 •8	•5 •6			
Frontal auxiliary blocks⁽¹⁾							
	2 contacts						
	1	1	-	-	ECFA211S	268872	5
	2	0	-	-	ECFA220S	268873	5
	0	2	-	-	ECFA202S	268874	5
	4 contacts						
	4	0	-	-	ECFA440S	268881	5
	3	1	-	-	ECFA431S	268882	5
	2	2	-	-	ECFA422S	268883	5
	1	3	-	-	ECFA413S	268884	5
	0	4	-	-	ECFA404S	268885	5
1	1	1	1	ECFA422SE	268886	5	
Lateral auxiliary blocks							
	Lateral auxiliary block for EC contactors⁽³⁾						
	2	0	-	-	ECLA220S	268899	10
	1	1	-	-	ECLA211S	268900	10
	0	2	-	-	ECLA202S	268901	10
	Lateral auxiliary block for EF contactors						
	2	0	-	-	BCLL20	104706	10
	1	1	-	-	BCLL11	104707	10
	Mechanical interlock for EC contactors						
	0	0	-	-	ECMI	268908	10
	0	2	-	-	ECMI02S	268910	10
Mechanical interlock for EF contactors							
0	0	-	-	BELA	104723	10	
0	2	-	-	BELA02	104724	10	

Pneumatic timer⁽²⁾

	NO	NC	Time	Type	Box clamp terminals		Pack
					Cat. no.	Ref. no.	
	•7 •8	•5 •6					
	1	1	0.1-30 s	delay ON	ECPT30SC	268913	5
	1	1	1-60 s	delay ON	ECPT60SC	268914	5
	1	1	0.1-30 s	delay OFF	ECPT30SD	268916	5
	1	1	1-60 s	delay OFF	ECPT60SD	268917	5

(1) All frontal auxiliary blocks can be used with all contactor types.

(2) The pneumatic timer can be used with all contactor types.

(3) EC*E Lateral Auxiliary can only be mounted on right side

Surge suppressor

Description	Cat. no.	Ref. no.	Pack	Description	Cat. no.	Ref. no.	Pack
Diode type, DC 12-440V	ECSUDI440	268931	10	R-C type, AC 12-48V	BSLR3G	104716	-
R-C type, AC 24-48V	ECSURC048	268932	10	R-C type, AC 50-127V	BSLR3K	104717	-
R-C type, AC 50-127V	ECSURC127	268933	10	R-C type, AC 130-250V	BSLR3R	104718	-
R-C type, AC 130-250V	ECSURC250	268934	10	Varistor type, 24-48V	BSLV3G	104720	-
R-C type, AC 230-440V	ECSURC440	268935	10	Varistor type, 50-127V	BSLV3K	104721	-
R-C type, AC 400-600V	ECSURC600	268936	10	Varistor type, 130-250V	BSLV3R	104722	-
Varistor type, AC/DC 24-48V	ECSUVA048	268937	10	Varistor type, 277-500V	BSLV3U	110836	-
Varistor type, AC/DC 50-127V	ECSUVA127	268938	-				
Varistor type, AC/DC 130-250V	ECSUVA250	268939	-				
Varistor type, AC/DC 230-440V	ECSUVA440	268940	-				

(1) EF contactors with electronic coil version have always surge suppressor built-in. There is no need to buy surge suppressor protection separately.

Accessories for starters

Fuseless starter kits

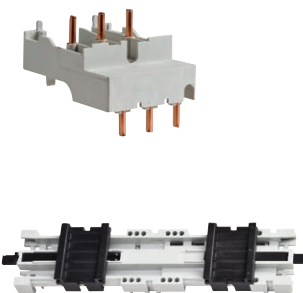
	Use with	Description	Cat. no.	Ref. no.	Pack
	GPS1 - EC09 up to EC25	Link module for AC and AC/DC version	ECM1AL25	268954	5
GPS1 - EC32	Link module for AC and AC/DC version	ECM1AL32	268955	5	
GPS2 - EC32 and EC40	Link module for AC and AC/DC version	ECM2AL40	268956	5	
GPS2 - EF50E up to EF80E	Link module	EFM2EL80	255000	1	
GPS2 - EF50A up to EF80A	Link module	EFM2AL80	255035	1	
GPS1 - EC09 up to EC32	Base plate 45mm	ECBP45	268962	5	
GPS2 - EC32 and EC40	Base plate 55mm	ECBP55	268953	5	

Wiring kits for reversing starters

	Use with	Description	Cat. no.	Ref. no.	Pack
	Suitable for upper and lower connections with and without overload relay with mechanical interlock				
EC09 up to EC25		ECKS1RV	268948	1	
EC32 and EC40		ECKS2RV	268950	1	
EF50 up to EF80		CLXC41	255036	1	
EF95 up to EF105		CLXC51	255001	1	

Parallel busbar

	Use with	Description	Cat. no.	Ref. no.	Pack
	EC09 up to EC25	Parallel busbar for 2 contactors	ECBB1B2	268942	5
EC32 and EC40	Parallel busbar for 2 contactors	ECBB2B2	268945	5	

Parallel poles

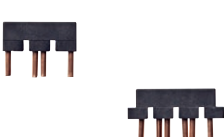
	Use with	Description	Cat. no.	Ref. no.	Pack
	EC09 up to EC25	3 poles in parallel	EC3PP1B	268943	6
EC09 up to EC25	4 poles in parallel	EC4PP1B	268944	6	
EC32 and EC40	3 poles in parallel	EC3PP2B	268946	6	
EC32 and EC40	4 poles in parallel	EC4PP2B	268947	6	

Wiring kits for star delta starters

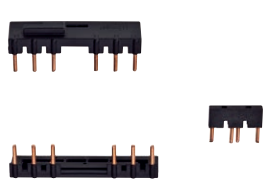
	Use with	Description	Cat. no.	Ref. no.	Pack
	Suitable for upper and lower connections with or without overload relay				
EC09 up to EC25		ECKS1VD	268951	1	
EC32 and EC40		ECKS2VD	268952	1	
EF50		CLXC42	255002	1	
EF65 and EF80		CLXC43	255003	1	
EF95 and EF105		CLXC52	255004	1	

Everything is under control

Three pole minicontactors 7A (AC3) 16A (AC1)

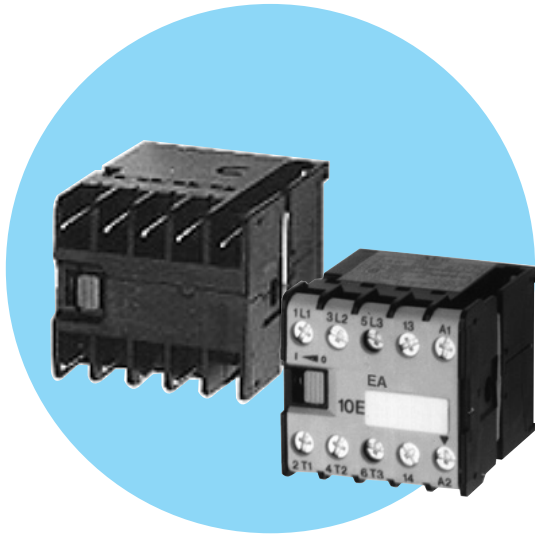
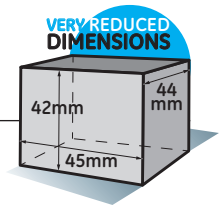

- Control circuit:
 - Alternating current up to 230V AC at 50/60Hz
 - Direct current up to 110V DC
- Low consumption:
 - Only 1.2W In DC
 - 2.4VA In AC
- Power circuit: Up to 400V AC
- Rating:
 - 7.3A AC3 at 400V
 - 16A AC1
 - Ith 16A
 - AC15: - 6A 230V
 - 4A 400V
 - A600
 - P300
- Motor rating AC-3 duty, 3 phases
 - 230V 1.5kW
 - 400/415V 3kW
- Very reduced dimensions: 42/45/44mm (HxWxD)
- Lateral carrier
- Terminal numbering in accordance with EN 50012
- Fixing by clipping onto 35mm DIN-rail (EN 50022-35) or by screws
- Terminal versions:
 - Screws as standard
 - Solder pin for circuit board application
- Integrated one auxiliary contact block: 1NO or 1NC
- No accessories
 - No available additional auxiliary contacts
 - Stand-alone thermal protection

Standards

IEC/EN 60947-1
IEC/EN 60947-4-1
VDE 0660
BS5424

Approvals/Marking



3 Pole Contactors



Power rating AC3 (kW)		Terminal	Poles	Auxiliary contacts		Control circuit	Voltage	Cat. no.	Ref. no.	Pack
230V	400V			NO	NC					
1.5	3	Screw	3	1	0	AC	24	EA07A310S024	247990	10
1.5	3	Screw	3	0	1	AC	24	EA07A301S024	247991	10
1.5	3	Screw	3	1	0	AC	48	EA07A310S048	247992	10
1.5	3	Screw	3	0	1	AC	48	EA07A301S048	247993	10
1.5	3	Screw	3	1	0	AC	110	EA07A310S110	247994	10
1.5	3	Screw	3	0	1	AC	110	EA07A301S110	247995	10
1.5	3	Screw	3	1	0	AC	230	EA07A310S230	247996	10
1.5	3	Screw	3	0	1	AC	230	EA07A301S230	247997	10
1.5	3	Screw	3	1	0	DC	24	EA07D310S024	247998	10
1.5	3	Screw	3	0	1	DC	24	EA07D301S024	247999	10
1.5	3	Screw	3	1	0	DC	110	EA07D310S110	248000	10
1.5	3	Screw	3	0	1	DC	110	EA07D301S110	248001	10
0.75	1.5	Solder pin	3	1	0	AC	24	EA07A310I024	248004	10
0.75	1.5	Solder pin	3	0	1	AC	24	EA07A301I024	248005	10
0.75	1.5	Solder pin	3	1	0	DC	24	EA07D310I024	248006	10
0.75	1.5	Solder pin	3	0	1	DC	24	EA07D301I024	248007	10
0.75	1.5	Solder pin	3	1	0	DC	110	EA07D310I110	248008	10
0.75	1.5	Solder pin	3	0	1	DC	110	EA07D301I110	248009	10
0.75	1.5	Solder pin	3	1	0	AC	230	EA07A310I230	248002	10
0.75	1.5	Solder pin	3	0	1	AC	230	EA07A301I230	248003	10

Order codes

Intro

A

B

C

D

E

F

G

H

I

X



Three and four pole compact contactors 9 and 12A (AC3) 20A (AC1)

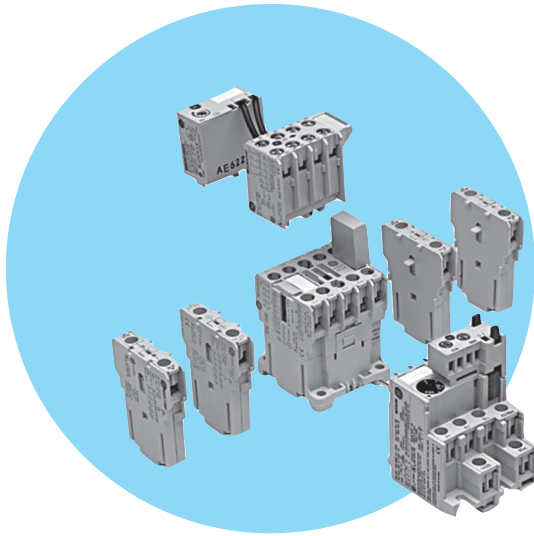

Standards

IEC/EN 60947-1	BS 4794
IEC/EN 60947-4-1	NFC 63-110
IEC/EN 60947-5-1	CSA C22.2/14
EN 50003	VDE 0660
EN 50005	SEV 10254
EN 50012	JIS C8325
UL 508	JEM 1038
NEMA ICS-1	CENELEC HD 419

Approvals/Marking



Lloyd's Register

Bureau Veritas

CE



(Contact GE for details)

General data

- Control circuit: Alternating current up to 600V
Direct current up to 440V
- Terminal numbering in accordance with EN 50012
- Fixing by clipping onto 35 mm DIN rail (EN 50022-35) or by screws
- 6kV rated impulse withstand strength
- Screws and fast-on terminals protected against accidental contact in accordance with VDE 0106 T.100 and VBG4
- Versions: Ring terminal and printed circuit terminals
- Facility to mount instant and timed auxiliary contact blocks and voltage suppressor block
- Degree of protection IP20 (EN 60529).
- Maximum number of auxiliary contacts to be added: 6

	MC1...	MC2...
Maximum number of poles	4	4
Rated thermal current (I_{th}) $\theta \leq 60^\circ$ (1)	(A) 20	20
Rated operational current I_e (2) (3 x 440V, 50/60Hz, AC3)	(A) 9	12
Rated insulation current U_i	(V) 750	750
Rated operational current U_e	(V) 690	690

Standard voltages

To complete the catalogue number, replace the symbol ♦ by the code corresponding to the voltage and frequency of the control circuit (other voltages on request)

AC Coils

	1	2	9	J	K	M	6	7	N	U	W	Y
50/60Hz	24	42	48				220-230	240				
50 Hz				110-115	115-127					380-400	415-440	500
60Hz				110-120		208-220			277	440	480	600

Operating voltage limits with bifrequency coils:

With 60Hz = 0.85 to 1.1 x U_s

With 50Hz = 0.8 to 1.1 x U_s in continuous service (ED = 100%) with a maximum ambient temperature of 40°C

DC Coils

	B	D	G	J
Voltage	12	24	48	110

DC Wide Range Coils

	WD	WG	WI	WJ	WL	WN	WS
Voltage	24	48	72	110	125	220	250

Operating voltage limits with DC coils:

Standard = 0.8 to 1.1 x U_s

Wide Range = 0.7 to 1.3 x U_s

- Order codes ● page A.34
- Auxiliary contact blocks ● page A.37
- Accessories ● page A.39
- Technical data ● page A.79
- Terminal numbering ● page A.85
- Dimensions ● page A.118

Three pole contactors

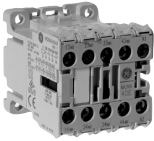

Max.operat.current Non- inductive loads AC1 ⁽²⁾ A	Motors <480V, 3 ~ 50/60Hz AC3 ⁽³⁾ A	Admissible power AC3						Aux. contacts		Control circuit: Alternating current		Control circuit: Direct current	
		1-phase		3-phase				.3 .4	.1 .2	Cat. no. ⁽¹⁾	Pack	Cat. no. ⁽¹⁾	Pack
		115V	220V	220-240V	380-415V	440-480V	690V						
Terminal: screw													
20	9	0.56	1.12	2.2	4	-	7.5	1	0	MC1A310AT ♦	20	MC1C310AT ♦	10
		0.75	1.5	3	5	5	-	0	1				
20	12	0.75	2	3	5.5	-	7.5	1	0	MC2A310AT ♦	20	MC2C310AT ♦	10
		1	2.6	3	7.5	7.5	-	0	1				
Terminal: ring terminal													
20	9	0.56	1.12	2.2	4	-	7.5	1	0	MC1A310AR ♦	20	MC1C310AR ♦	10
		0.75	1.5	3	5	5	-	0	1				
20	12	0.75	2	3	5.5	-	7.5	1	0	MC2A310AR ♦	20	MC2C310AR ♦	10
		1	2.6	3	7.5	7.5	-	0	1				
Terminal: faston 2x2.8 insulated⁽⁵⁾													
16 ⁽⁴⁾	9	0.56	1.12	2.2	4	-	7.5	1	0	MC1A310AF ♦	20	MC1C310AF ♦	10
		0.75	1.5	3	5	5	-	0	1				
		-	-	3	5.5	-	7.5	-	-				
		-	-	3	7.5	7.5	-	-	-				
Terminal: printed circuit													
20	9	0.56	1.12	2.2	4	-	7.5	1	0	MC1A310AI ♦	20	MC1C310AI ♦	10
		0.75	1.5	3	5	5	-	0	1				
20	12	0.75	2	3	5.5	-	7.5	1	0	MC2A310AI ♦	20	MC2C310AI ♦	10
		1	2.6	3	7.5	7.5	-	0	1				
Spare coil										MB0A ♦	10	MB0C ♦	10

(1) To complete the catalogue number, replace the symbol ♦ by the code corresponding to the voltage and frequency of the control circuit (other voltages on request) (see A.34)
 (2) Electrical endurance AC-1: MC1... 0.3x10⁶ operations
 MC2... 0.35x10⁶ operations
 (3) Electrical endurance AC-3 as per B10d: MC1...(9A) = 1.4 x 10⁶ operations
 MC2...(12A) = 1 x 10⁶ operations
 (4) Terminal with wire 1.5mm²: I_e = 16A
 with wire 1mm²: I_e = 10A
 Insulated terminal type B 2.8x0.8 and wire 1mm² I_e = 8A in accordance with DIN 46247.
 (5) Fast-on 1x6.3 terminals on request (replace letter F by H in the catalogue number)



Interface contactors

Max. oper. current Non-inductive load AC1 A	Motors <480V, 3 ~ 50/60Hz AC3 ⁽³⁾ A	Admissible power AC3						Aux. contacts		Voltage 24V D.C, coil 1.2W ⁽¹⁾			Voltage 24V D.C, coil 2W ⁽²⁾			
		1-phase		3-phase				.3 .4	.1 .2	Cat. no. ⁽¹⁾	Ref. no.	Pack	Cat. no. ⁽¹⁾	Ref. no.	Pack	
		115V	220V	220-240V	380-415V	440-480V	690V									kW
Terminal: screw																
20	9	0.56	1.12	2.2	4	-	7.5	1	0	MC1I310ATD	100572	10	MC1K310ATD	100576	10	
		0.75	1.5	3	5	5	-	0	1	MC1I301ATD	100573	10	MC1K301ATD	100577	10	
		-	-	-	-	-	-	-	-	-	-	-	MC1K400ATD	100569	10	
20	12	0.75	2	3	5.5	-	7.5	1	0	MC2I310ATD	100559	10	MC2K310ATD	103590	10	
		1	2.6	3	7.5	7.5	10	0	1	MC2I301ATD	100538	10	MC2K301ATD	103591	10	
		-	-	-	-	-	-	-	-	-	-	-	MC2K400ATD	103037	10	
Spare coil										MB0ID	100470	10	MB0KD	100471	10	

- (1) No possibility of adding instantaneous auxiliary contact blocks.
- (2) Facility to mount an instantaneous auxiliary contact block of two contacts or two instantaneous auxiliary contact blocks of one contact.
- (3) Electrical endurance AC-3 as per B10d: MC1...(9A) = 1.4×10^6 operations
MC2...(12A) = 1.4×10^6 operations

Order codes

Intro

A

B

C

D

E

F

G

H

I

X



Four poles contactors



Max.oper.current Non-inductive load AC1 ⁽²⁾ A	Motors <480V, 3 ~ 50/60Hz AC3 ⁽³⁾ A	Admissible power AC3						Poles		Control circuit: Alternating current		Control circuit: Direct current		
		1-phase		3-phase				d	b	Cat. no. ⁽¹⁾	Pack	Cat. no. ⁽¹⁾	Pack	
		115V	220V	220-240V	380-415V	440-480V	690V			Ref. no. see bottom		Ref. no. see bottom		
		kW	kW	kW	kW	kW	kW							
		HP	HP	HP	HP	HP	HP							
Screw terminal														
20	9	AC1						4	0	MC1A400AT ♦	10	MC1C400AT ♦	10	
		2.3	4.4	7.5	13	17	22.5	3	1	MC1AC00AT ♦	10	MC1CC00AT ♦	10	
		-	-	-	-	-	-	2	2	MC1AB00AT ♦	10	MC1CB00AT ♦	10	
		AC3						0	4	MC1AA00AT ♦	10	MC1CA00AT ♦	10	
		0.56	1.12	2.2	4	-	7.5							
		0.75	1.5	3	5	5	-							
20	12	AC1						4	0	MC2A400AT ♦	10	MC2C400AT ♦	10	
		2.3	4.4	7.5	13	17	22.5	3	1	MC2AC00AT ♦	10	MC2CC00AT ♦	10	
		-	-	-	-	-	-	2	2	MC2AB00AT ♦	10	MC2CB00AT ♦	10	
		AC3												
		0.75	2	3	5.5	-	7.5							
		1	2.6	3	7.5	7.5	-							
Terminal: faston 2 x 2.8 insulated⁽⁵⁾														
16 ⁽⁴⁾	9	AC1						4	0	MC1A400AF ♦	20	MC1C400AF ♦	10	
		2.3	4.4	7.5	13	17	22.5	2	2	MC1AB00AF ♦	20	MC1CB00AF ♦	10	
		-	-	-	-	-	-	0	4	MC1AA00AF ♦	20			
		AC3												
		0.56	1.12	2.2	4	-	7.5							
		0.75	1.5	3	5	5	-							
Terminal: printed circuit														
20	9	AC1						4	0	MC1A400AI ♦	20	MC1C400AI ♦	10	
		2.3	4.4	7.5	13	17	22.5	2	2	MC1AB00AI ♦	20	MC1CB00AI ♦	10	
		-	-	-	-	-	-	0	4	MC1AA00AI ♦	20			
		AC3												
		0.56	1.12	2.2	4	-	7.5							
		0.75	1.5	3	5	5	-							
Spare coil										MB0A ♦	10	MB0C ♦	10	

(1) To complete the catalogue number, replace the symbol ♦ by the code corresponding to the voltage and frequency of the control circuit (see A.34)
 (2) Electrical endurance AC-1: MC1... 0.3 x 10⁶ operations
 MC2... 0.35 x 10⁶ operations
 (3) Electrical endurance AC-3 as per B10d: MC1...(9A) = 1.4 x 10⁶ operations
 MC2...(12A) = 1 x 10⁶ operations
 (4) Terminal with wire 1.5mm²: I_e = 16A
 with wire 1mm²: I_e = 10A
 Insulated terminal type B 2.8x0.8 and wire of 1mm² I_e = 8A in accordance with DIN 46247.
 (5) Faston 1 x 6.3 terminals on request, (replace letter F by H in the catalogue number).



Instantaneous auxiliary contact blocks

Front mounting

Number contacts	Combinations with basic contactor 10E	Contacts in acc. with EN 50012	Contacts in acc. with EN 50005	Aux. contacts		Cat. no.	Ref. no.	Pack
				.3 .4	.1 .2			
• Two or four additional contacts, to cover combinations of 3 or 5 contacts without increasing the surface area of the basic contactor								
Screw terminal								
2	21E	11		1	1	MACN211AT	100999	10
2	12E	02		0	2	MACN202AT	100998	10
2			20	2	0	MARN220AT	100994	10
2			11	1	1	MARN211AT	100993	10
2			02	0	2	MARN202AT	100992	10
4	41E	31		3	1	MACN431AT	100997	10
4	32E	22		2	2	MACN422AT	100996	10
4	23E	13		1	3	MACN413AT	100995	10
4			40	4	0	MARN440AT	100991	10
4			31	3	1	MARN431AT	100990	10
4			22	2	2	MARN422AT	100989	10
4			13	1	3	MARN413AT	100988	10
4			04	0	4	MARN404AT	100987	10
Ring terminal								
2	21E	11		1	1	MACN211AR	103557	10
2	12E	02		0	2	MACN202AR	103558	10
2			20	2	0	MARN220AR	103349	10
2			11	1	1	MARN211AR	103350	10
2			02	0	2	MARN202AR	103351	10
4	41E	31		3	1	MACN431AR	103559	10
4	32E	22		2	2	MACN422AR	103560	10
4	23E	13		1	3	MACN413AR	103561	10
4			40	4	0	MARN440AR	103352	10
4			31	3	1	MARN431AR	103353	10
4			22	2	2	MARN422AR	103354	10
4			13	1	3	MARN413AR	103355	10
4			04	0	4	MARN404AR	103300	10



Order codes

Intro

A

B

C

D

E

F

G

H

I

X



Instantaneous auxiliary contact blocks (continued)





Lateral mounting



Number contacts	Combinations with basic contactor 10E	Contacts in acc. with EN 50012	Contacts in acc. with EN 50005	Aux. contacts		Cat. no.	Ref. no.	Pack
				.3 .4	.1 .2			
<ul style="list-style-type: none"> One or two additional blocks, to cover combinations of 1 or 2 contacts without increasing the height of the basic unit contactor 								
Screw terminal								
1	20	10		1	0	MACL110AT	100560	10
1	11E	01		0	1	MACL101AT	100561	10
Ring terminal								
1	20	10		1	0	MACL110AR	103555	10
1	11E	01		0	1	MACL101AR	103556	10
Terminal: faston 2x2.8 insulated⁽¹⁾								
1	20	10		1	0	MACL110AF	100562	10
1	11E	01		0	1	MACL101AF	100563	10
Terminal: printed circuit								
1	20	10		1	0	MACL110AI	100564	10
1	11E	01		0	1	MACL101AI	100565	10
<ul style="list-style-type: none"> One or two additional blocks, when up to 6 or 7 contacts are needed (combination possible with frontal blocks) One or two additional blocks on both sides, to cover up to five contacts (combination possible only with lateral blocks) 								
Screw terminal								
1			10	1	0	MARL110ATS	100519	10
1			01	0	1	MARL101ATS	100520	10
Ring terminal								
1			10	1	0	MARL110ARS	103299	10
1			01	0	1	MARL101ARS	103298	10
Terminal: faston 2x2.8 insulated⁽¹⁾								
1			10	1	0	MARL110AFS	100521	10
1			01	0	1	MARL101AFS	100522	10
Terminal: printed circuit								
1			10	1	0	MARL110AIS	100523	10
1			01	0	1	MARL101AIS	100524	10

(1) Terminal with wire 1mm²: Ie = 10A
Insulated terminal type B 2.8x0.8 with wire 1mm²: Ie = 8A, in accordance with DIN 46247

Accessories

	For use with:	Time	Function	Ue	Cat. no.	Ref. no.	Pack
 <p>Electronic timer block</p>	Lateral or front fixing to the contactor						
	MCR, MC ...	0.5 - 60 seg.	delay ON	24...250V AC/DC	MREBC10AC2	100541	10
	MCR, MC ...	0.2 - 24 seg.	delay ON	24...250V AC/DC	MREBC20AC2	100542	10
 <p>DIN-rail adaptor for electronic timer block</p>	For fixing onto EN 50022-35						
	MREBC...				MVBOR	100543	10
 <p>Voltage suppressor block</p>	Connection and (plug-in) fixing on to the connector						
	MCRA, MC ...	R/C	AC	12...60V 50/60Hz	MP0AAE1	100544	10
	MCRA, MC ...	R/C	AC	72...240 V 50/60 Hz	MP0AAE2	100545	10
	MCRC, MC ...	Diode	DC	6...240 V DC	MP0CAE3	100546	10
	MCRC, MC ...	Varistor	AC/DC	24-48V	MP0DAE4	100536	10
	MCRC, MC ...	Varistor	AC/DC	50-127V	MP0DAE5	204848	10
	MCRC, MC ...	Varistor	AC/DC	130-250V	MP0DAE6	204849	10
 <p>Pole paralleling links</p>	To connect two, three or four phases in parallel						
	MC ...	2, 3, 4 (parallel)	Ø4.5mm - 16mm ²		MVPOC	100600	10
 <p>Mechanical interlock</p>	Mechanical interlock and pole jumpers						
	MCR, MC ...				MMHO	100547	10
<p>Identification</p>	Cat. no.						
	Ref. no.						
	Pack						
	MCR, MC ...	Labels (10 sheets of 260 labels)			EAT 260	100548	1
	MCR, MC ...	Labelling plate base. Plug-in labelling plate bases (50 pieces in one pack)			SPR	100549	1

Order codes

Intro

A

B

C

D

E

F

G

H

I

X



Direct-on-line starters

6 to 12A (AC-3)

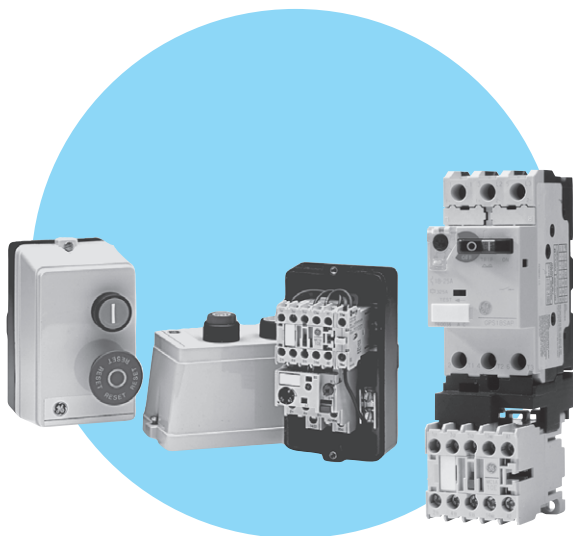

- Power circuit: up to 690V AC
- Control circuit: up to 600V AC
- Polycarbonate enclosure (IP40 - IP65)
 - Shock resistance
 - Total insulation \square
 - 4 knock-out input holes PG13.5
 - Cable entry in the base
- Terminals protected against accidental contact
- 16 setting ranges from 0.11 up to 14A
- Start contact block

Series M - Direct-on-line starters

	Push-buttons	Protection degree		Cat. no.	Ref. no.	Pack.
Empty boxes	Start/Stop + Reset	IP40		MG0004PATO	209780	1
		IP65		MG0006PATO	209781	1
	Reset only	IP40		MG0004RATO	137557	1
		IP65		MG0006RATO	116402	1
	Start/Emergency stop	IP40		MG0004QATO	137556	1
		IP65		MG0006QATO	116074	1
Start contact block	Laterally mounted to the contactor, allowing the electrical operation the box push-button which incises on it.			MAGL110AT	100608	1

Series M - Reversing starters

	Description	For use with contactor	AC / DC	Cat. no.	Ref. no.	Pack.
 Wiring kits for reversing starters	Suitable to be used with link modules Upper and lower connections without overload relays	MC1.., MC2..	AC / DC	WKMIU	101421	1

Fuseless starters

	Frame size	For use with contactor	AC / DC	Cat. no.	Ref. no.	Pack.
	GPS1	MC0.., MC1..	AC / DC	GPF1LMCBA	101410	5

Wiring diagrams ● page A.86
Dimensions ● page A.118



Three and four pole contactors 9 to 105A (AC3) 25 to 140A (AC1)

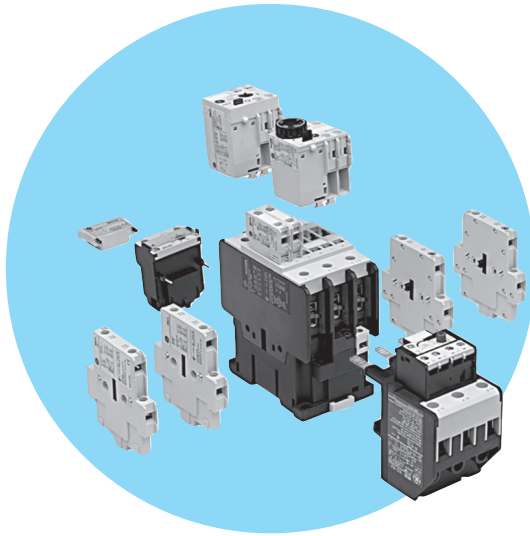

Standards/Marking

IEC/EN 60947-1	CSA 22.2/14
IEC/EN 60947-4-1	NFC 63-110
IEC/EN 60947-5-1	ASE 1025
EN 50005	VDE 0660/102
UL 508	CENELEC HD 419
NEMA ICS 1	
BS 5424 & 775	

Approvals

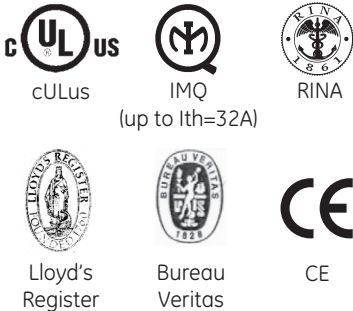

 (Contact GE for details)

- Control circuit: Alternating current up to 690V
Direct current up to 440V
- Terminal numbering in accordance with EN 50005 and EN 50012
- Fixing by clipping onto 35mm DIN rail EN 50022-35 or by screws
- Screws protected against accidental contact in accordance with VDE 0106 T.100, VBG4.
- Ring terminal version
- Three coil terminals
- Mounting possibilities of front/side instantaneous auxiliary contact blocks, timed auxiliary contact blocks, mechanical latch, transient suppressor block and interface modules.
- Degree of protection: IP20 to CL00 ... CL02
IP10 to CL03 ... CL10

Standard voltages

To complete the catalogue number, replace the symbol \blacklozenge by the code corresponding to the voltage and frequency of the control circuit.

AC Coils (V)

	-	1	2	9	J	K	L	6	7	N	U	Y
50/60Hz	24	42	48					220-230	240			
50 Hz					110-115	127					380-400	500
60Hz					110-120		208			277	480	600

Operating voltage limits with bifrequency coils:

With 60Hz = 0.85 to 1.1 x Us

With 50Hz = 0.8 to 1.1 x Us in continuous service (ED = 100%) with a maximum ambient temperature of 40°C

DC Coils

	-	B	D	G	H	J	K	N	T
Voltage		12	24	48	60	110	120-125	220	250

DC Wide Range Coils

	-	WD	WE	WG	WI	WJ	WN
Voltage		24	33	48	72	110	220

Operating voltage limits with DC coils:

Standard = 0.8 to 1.1 x Us

Wide Range = 0.7 to 1.3 x Us

AC/DC Coils

	-	WD	WH	WJ	WU
Voltage		24-60	48-130	100-250	250-500

Operating voltage limits with AC/DC coils:

Standard = 0.8 to 1.1 x Us

- Order codes ● page A.42
- Auxiliary contact blocks ● page A.44
- Accessories ● page A.44
- Technical data ● page A.88
- Terminal numbering ● page A.96
- Dimensions ● page A.120





Three pole contactors. Screw terminal



Max.oper.current Non- inductive load AC1 A	Motors <480V, 3 ~ 50/60Hz AC3 A	Admissible power AC3				Electrical endurance Operations	Aux. contacts		Control circuit: Alternating current		Control circuit: Direct current		Control circuit: Coil with electronic module (AC/DC)		
		220- 240V	380- 415V	440- 480V	690V		Cat. AC3 Operations	.3 .4	.1 .2	Cat. no. ⁽¹⁾	Pack ⁽³⁾	Cat. no. ⁽¹⁾	Pack ⁽³⁾	Cat. no. ⁽¹⁾	Pack ⁽³⁾
		kW HP	kW HP	kW HP	kW HP										
25	9	2.2	4	-	5.5	2×10 ⁶	1	0	CL00A310T ♦	5	CL00D310T ♦	10	-	-	
		3	5	5	-										CL00A301T ♦
25	12	3	5.5	-	7.5	2×10 ⁶	1	0	CL01A310T ♦	5	CL01D310T ♦	10	-	-	
		3	7.5	7.5	-										CL01A301T ♦
32	18	4	7.5	-	10	1.7×10 ⁶	1	0	CL02A310T ♦	5	CL02D310T ♦	10	-	-	
		5.5	10	10	-										CL02A301T ♦
45	25	7.5	11	-	15	1.2×10 ⁶	0	0	CL03A300T ♦	5	CL03D300T ♦	10	-	-	
		7.5	15	15	-										-
60	32	9	15	-	18.5	2×10 ⁶	1	0	CL04A310M ♦	10	CL04D310M ♦	10	-	-	
		10	15	20	-										CL04A301M ♦
60	50	15	22	-	30	0.8×10 ⁶	0	0	CL05A300M ♦	10	CL05D300M ♦	10	-	-	
		15	30	30	-										-
110	65	18.5	30	-	45	1.7×10 ⁶	0	0	CL07A300M ♦	1	CL07D300M ♦	1	CL07E300M ♦	1	
		20	40	40	-										-
110	80	22	37	-	45	1.5×10 ⁶	0	0	CL08A300M ♦	1	CL08D300M ♦	1	CL08E300M ♦	1	
		25	50	50	-										-
140	95	25	45	-	55	1.7×10 ⁶	0	0	CL09A300M ♦	1	CL09D300M ♦	1	CL09E300M ♦	1	
		30	60	60	-										-
140	105	30	55	-	65	1.5×10 ⁶	0	0	CL10A300M ♦	1	CL10D300M ♦	1	CL10E300M ♦	1	
		40	75	75	-										-
Spare coils						CL00-CL03			LB1A ♦	5	LB1D ♦	5	-	-	
						CL04-CL05			LB3A ♦	5	LB3D ♦	5	-	-	
						CL07-CL10			LB4A ♦	5	LB4D ♦	1	-	-	
						coil + electronic module CL07E-CL10E							LB4E ♦	1	

(1) To complete the catalogue number, replace the symbol ♦ by the code corresponding to the voltage and frequency of the control circuit (see page A.41).



Four pole contactors. Screw terminal

Max.oper.current Non-inductive loads	AC1 A	AC3 A	Admissible power AC1				Electrical endurance Cat. AC1 Operations	Power contacts		Control circuit: Alternating current		Control circuit: Direct current		Control circuit: Coil with electronic module (AC/DC)	
			220V 230V	380V 400V	415V 440V	500V		d	b	Cat. no. ⁽¹⁾	Pack ⁽²⁾	Cat. no. ⁽¹⁾	Pack ⁽²⁾	Cat. no. ⁽¹⁾	Pack ⁽²⁾
			kW	kW	kW	kW									
	25	12	9.5	16.5	18	21.5	1.5x10 ⁶	4	0	CL01A400T♦	5	CL01D400T♦	10	-	-
	32	18	12	22	23	27.5	1.5x10 ⁶	4	0	CL02A400T♦	5	CL02D400T♦	10	-	-
										CL02AA00T♦ ⁽³⁾	5	CL02DA00T♦ ⁽³⁾	10	-	-
	45	25	17	29	32	39	2x10 ⁶	4	0	CL03A400M♦	10	CL03D400M♦	10	-	-
	60	32	22.5	39.5	43	52	1.5x10 ⁶	4	0	CL04A400M♦	10	CL04D400M♦	10	-	CL05E400M♦
	90	50	34	59	64	78	1.5x10 ⁶	4	0	CL05A400M♦	1	CL05D400M♦	1	-	CL07E400M♦
	110	65	42	72.5	79	95	1.8x10 ⁶	4	0	CL07A400M♦	1	CL07D400M♦	1	-	CL09E400M♦
	140	95	53	92	100	121	1.8x10 ⁶	4	0	CL09A400M♦	1	CL09D400M♦	1	-	-

Max.oper.current Non-inductive loads	Motors <440V, 3~ 50/60Hz AC3 A	Admissible power AC3				Power contacts	Control circuit: Alternating current		Control circuit: Direct current		Control circuit: Coil with electronic module (AC/DC)			
		220V 230V	380V 400V	415V 440V	500V		d	b	Cat. no. ⁽¹⁾	Pack ⁽²⁾	Cat. no. ⁽¹⁾	Pack ⁽²⁾	Cat. no. ⁽¹⁾	Pack ⁽²⁾
		kW HP	kW HP	kW HP	kW HP									
	25	12	3 4	5.5 7.5	5.5 7.5	7.5 10	2	2	CL01AB00T♦	5	CL01DB00T♦	5	-	-
	32	18	4 5.5	7.5 10	7.5 10	10 13.5	2	2	CL02AB00T♦	5	CL02DB00T♦	5	-	-
									CL03AB00M♦	10	CL03DB00M♦	10	-	-
	45	25	7.5 10	12 16	12 16	15 20	2	2	CL03AB00M♦	10	CL03DB00M♦	10	-	-
	60	32	9 12	16 22	16 22	18.5 25	2	2	CL04AB00M♦	10	CL04DB00M♦	10	-	-
	90	50	11 15	18.5 25	22 30	25 34	2	2	CL05AB00M♦	1	CL05DB00M♦	1	CL05EB00M♦	1
									CL07AB00M♦	1	CL07DB00M♦	1	CL07EB00M♦	1
	110	65	18.5 25	30 40	37 50	40 55	2	2	CL07AB00M♦	1	CL07DB00M♦	1	CL07EB00M♦	1
	110	80	22 30	37 50	45 60	45 60	2	2	CL08AB00M♦	1	CL08DB00M♦	1	CL08EB00M♦	1

Spare coils	CL01-CL02		CL03-CL04		CL05A - CL08A		Coil + Electronic module CL05E - CL08E	
	Cat. no. ⁽¹⁾	Pack ⁽²⁾	Cat. no. ⁽¹⁾	Pack ⁽²⁾	Cat. no. ⁽¹⁾	Pack ⁽²⁾	Cat. no. ⁽¹⁾	Pack ⁽²⁾
	LB1A ♦	5	LB1D ♦	5	LB4A ♦	5	LB4E ♦	1
	LB3A ♦	5	LB3D ♦	5	LB4D ♦	1	-	-

(1) To complete the catalogue number, replace the symbol ♦ by the code corresponding to the voltage and frequency of the control circuit (see A.42).
 (2) Multipack, see A.43
 (3) CL02_A... (4 N.C. contacts) have no possibility of adding auxiliary contacts blocks.

Order codes

Intro

A

B

C

D

E

F

G



H

I



X



Auxiliary contact blocks

Instantaneous		Number of contacts	Contacts				Type	Time	Cat. no.	Ref. no.	Pack
			•3 •4	•1 •2	•7 •8	•5 •6					
	Frontal mounting	Terminal: screw									
		1	1	0	0	0			BCLF10	104700	10
		1	0	1	0	0			BCLF01	104701	10
		1	0	0	1	0			BCLF10G	104702	10
		1	0	0	0	1			BCLF01G	104703	10
	Side mounting	Terminal: screw									
		2	2	0	0	0			BCLL20	104706	10
		2	1	1	0	0			BCLL11	104707	10
		For combinations of more than 4 front-mounted and 2 side-mounted auxiliary contact blocks									
		2	2	0	0	0			BRL20	104704	10
		2	1	1	0	0			BRL11	104705	10
		2	0	2	0	0		BRL02	106622	10	
Pneumatic timer											
	Front mounting	Terminal: screw									
		2	0	0	1	1	Delay ON	0.1 - 30 sec.	BTLF30C	104709	10
		2	0	0	1	1	Delay ON	1 - 60 sec.	BTLF60C	104710	10
		2	0	0	1	1	Delay OFF	0.1 - 30 sec.	BTLF30D	104711	10
		2	0	0	1	1	Delay OFF	1 - 60 sec.	BTLF60D	104712	10
		Terminal: ring terminal									
		2	0	0	1	1	Delay ON	0.1 - 30 sec.	BTRF30C	108903	10
		2	0	0	1	1	Delay ON	1 - 60 sec.	BTRF60C	108904	10
		2	0	0	1	1	Delay OFF	0.1 - 30 sec.	BTRF30D	108905	10
		2	0	0	1	1	Delay OFF	1 - 60 sec.	BTRF60D	108906	10
		Sealing cover protection for pneumatic timer								BTLFX	113001

Accessories

		Number of contacts	Contacts				For use with:	Cat. no. ^[1]	Ref. no.	Pack
			•3 •4	•1 •2	•7 •8	•5 •6				
	Interlock	Mechanical								
		-	-	-	-	-	CL00 ... CL10	BELA	104723	5
		Mech./ electrical								
		2	0	2	-	-	CL00 ... CL10	BELA02	104724	5
	Mechanical latch blocks	Frontal mounted to the contactor								
							CL00 ... CL10	RMLF ♦	see bottom	10
		♦	D	G	HC	J	N	U	Y	
50Hz	24, 32	42, 48		110, 115, 120, 127	220, 230, 240	380, 400, 415, 440, 480	500, 660/690			
60Hz	24, 32	48, 60		110, 115, 120, 127	208, 220, 240, 277	380, 400, 415, 440, 480	600			
DC	24, 32, 36	42, 48	60, 72	110, 120, 125	220, 230, 240, 250	440				

1) To complete the catalogue number, replace the symbol ♦ by the code corresponding to the voltage and frequency of the control circuit (see A.42).



Accessories

	For use with	Type	Control circuit	Ue	Cat. no.	Ref. no.	Pack.
 Transient voltage suppressor block	Fixation to the coil terminals, that allows simultaneous use with the auxiliary contact blocks.						
	CL00 ... CL05A3	R/C	AC	12V ... 48V	BSLR2G	104713	10
	CL00 ... CL05A3	R/C	AC	50V ... 127V	BSLR2K	104714	10
	CL00 ... CL05A3	R/C	AC	130V ... 250V	BSLR2R	104715	10
	CL05A4, CL06 ... CL10A	R/C	AC	12V ... 48V	BSLR3G	104716	10
	CL05A4, CL06 ... CL10A	R/C	AC	50V ... 127V	BSLR3K	104717	10
	CL05A4, CL06 ... CL10A	R/C	AC	130V ... 250V	BSLR3R	104718	10
	CL ... D	Diode	DC	12V ... 600V	BSLDZ	104719	10
	CL00 ... CL10	Varistor	AC / DC	24V ... 48V	BSLV3G	104720	10
	CL00 ... CL10	Varistor	AC / DC	50V ... 127V	BSLV3K	104721	10
CL00 ... CL10	Varistor	AC / DC	130V ... 250V	BSLV3R	104722	10	
CL00 ... CL10	Varistor	AC / DC	277V ... 500V	BSLV3U	110836	10	

	For use with	Control circ.	Type	Time	Cat. no.	Ref. no.	Pack.
 Electronic timer module	Fixation to the coil terminals, that allows simultaneous use with the auxiliary contact blocks.						
	CL00 ... CL10	24-250V AC/DC	delay ON	0.1 - 2 sec.	BETL02C	113602	5
	CL00 ... CL10	24-250V AC/DC	delay ON	1.5 - 45 sec.	BETL45C	113603	5
	CL00 ... CL10	24-250V AC/DC	delay OFF	0.1 - 2 sec.	BETL02D	113604	5
	CL00 ... CL10	24-250V AC/DC	delay OFF	1.5 - 45 sec.	BETL45D	113605	5

Accessories

	For use with			Cat. no.	Ref. no.	Pack.
Identification	CL00 ... CL10	Sheets of labels (sheets of 260 labels each)		EAT 260	100548	1
	CL00 ... CL10	Labelling plate base (50 pieces in one pack)		SPR	100549	1
Pole terminal protector IPXXB	CL04			PTP04	113850	8
	CL05 3...			PTP45	113851	6
	CL05 4... CL08			PTP08	113852	8
	CL09 ... CL10			PTP10	113853	8

Series CL - Reversing starters

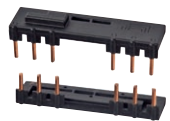
	Description	For use with contactor	AC / DC	Cat. no.	Ref. no.	Pack.
 Wiring kits for reversing starters	Suitable to be used with link modules	CL00.., CL01.., CL02..	AC / DC	WKLI02P	101422	1
	Upper and lower connections without overload relays					
Plate	Metallic plate	CL06, CL07, CL08		WKI0910	241751	1
		CL08, CL09, CL10		WKI0608	241752	1



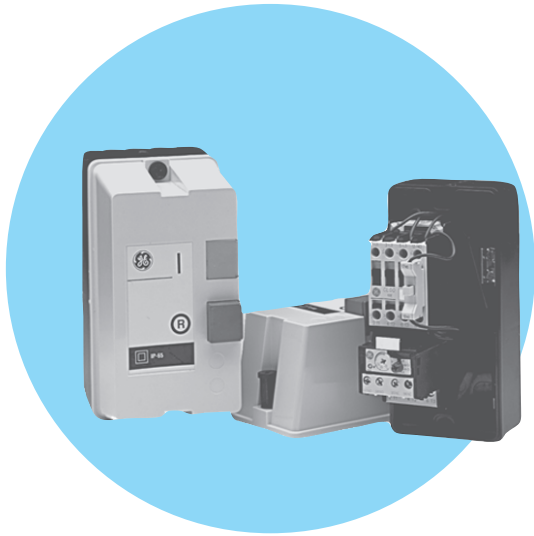

Direct-on-line starters

Series CL 9 to 105A (AC-3)

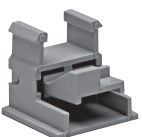

- Power circuit: up to 690V AC
- Control circuit: up to 690V AC
- Protection degree IP00
- Polycarbonate enclosure (IP40 - IP65)
 - Shock resistance
 - Total insulation
 - 4 knock-out input holes
- Empty enclosures version
- Start contact block

Series CL - Direct-on-line starters

	For use with	Push-buttons	Protection degree	Cat. no.	Ref. no.	Pack.	
	Empty boxes CL00, CL01, CL02	Start/Stop + Reset	IP40	LG0004P1B0	209344	1	
			IP65	LG0006P1B0	200004	1	
		Without push-buttons		IP40	LG0004S1B0	209347	1
				IP65	LG0006S1B0	116011	1
		CL03...T	Only Reset	IP40	LG0004R1B0	116651	1
				IP65	LG0006R1B0	116652	1
		CL03...T	Start/Stop + Reset	IP40	LG2504P1B0	100885	1
				IP65	LG2506P1B0	101095	1
		CL04	Only Reset	IP65	LG2506R1B0	133611	1
			Start/Stop + Reset	IP40	LG0404P1B0	116653	1
	CL03, CL04		IP65	LG0406P1B0	116656	1	
		Without push-buttons	IP40	LG0404S1B0	116996	1	
			IP65	LG0406S1B0	116997	1	
	Neutral terminal			BNL	104797	10	
	Conversion to permanent control	Pressure-fixed between push-buttons in direct-on-line enclosures for mechanical interlocking into permanent control.		EPL	104798	10	
	Start contact block spare part	Pressure-fixed onto the front of direct-on-line starters allowing electrical operation using the start push-button on the enclosure <i>Already built-in, order it as a spare part.</i>		BMLF	104800	10	

Fuseless starters and busbar adapter plates

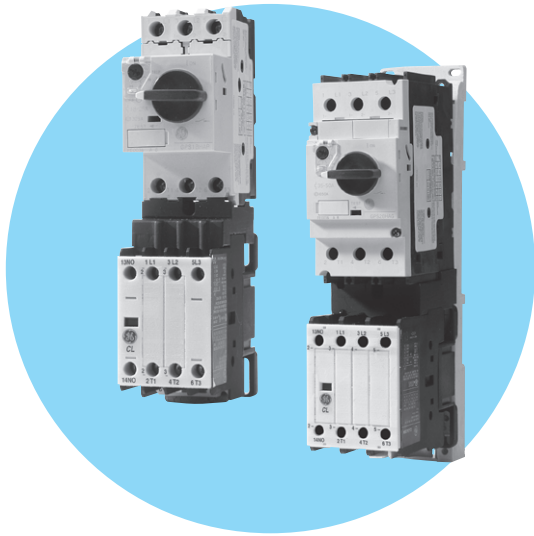

Technical performances

- Compact and high performance solution
- Easy accessibility to the contactor coil terminal A1-A2
- Save spacing only using 45 and 55mm width base plates for busbar adapters
- Quick “clip on” and secure connections
- Minimum 50kA short-circuit breaking capacity applies throughout

For fuseless starter application turn the contactor 180° to have direct accessibility to the A1-A2 coil terminals when contactor is assembled to the manual motor starter.

Note: when turning the contactor 180° the built-in auxiliary contact (in case) will be located on the first left side terminal.

Order codes

Intro

Fuseless starters

	Description	For use with contactor	ac/dc	Frame size	Cat. no.	Ref. no.	Pack.	
	Link modules For mechanical and electrical connection between contactors and manual motor starters	CL00A... CL01A... CL02A...	ac	GPS1	GPF1L02AA	101411	5	
		CL00D... CL01D... CL02D...	dc	GPS1	GPF1L02DA	101412	5	
		CL03A...	ac	GPS1	GPF1L25AA	101413	5	
		CL03D...	dc	GPS1	GPF1L25DA	101414	5	
		CL04A	ac	GPS1	GPF1L04AA	107165	5	
		CL04D	dc	GPS1	GPF1L04DA	107166	5	
		CL04A...	ac	GPS2	GPF2L04AA	107190	5	
		CL05A	ac	GPS2	GPF2L45AA	101415	5	
		CL04D...	dc	GPS2	GPF2L04DA	107191	5	
		CL05A	dc	GPS2	GPF2L45DA	101416	5	
		CL07A...	ac	GPS2	GPF2L07AA	101417	5	
		For mechanical and electrical connection between contactor and thermal overload relays RT1	CL00... - CL03	ac/dc	GPS1	GPF1L25CT1	101512	5
			CL04... - CL05	ac/dc	GPS2	GPF1L45CT1	101513	5
			Base plates Plastic plates for mounting the fuseless starter in panels or in 35mm DIN rail	CL00... CL01... CL02... CL03...	ac/dc	GPS1	GPF1B1A	101418
CL04... and CL05...	ac/dc			GPS2	GPF2B2A	101419	5	
CL07...	ac/dc			GPS2	GPF2B3A	101420	5	
CL04...	ac/dc			GPS1	GPF1B4A	107163	5	
	Link connector For two base plates for reversing applications	-	-	-	GPF1CBA	101427	10	

A

B

C

D

E

F

G

H

I

X



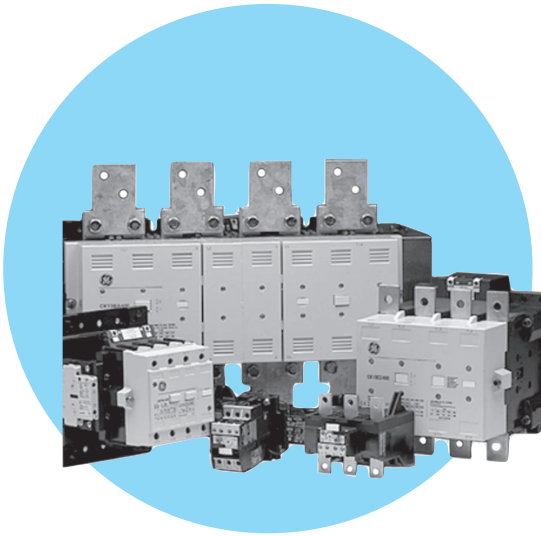

Three and four pole contactors 150 to 825A (AC3) 200 to 1250A (AC1)

- Control circuit: Alternating current up to 600V
AC/DC up to 500V
- Degree of protection IP00 (IPxxB with accessories)
- Auxiliary and coil terminals originally protected against accidental contacts.
Protection for power contacts on request (see accessories)
- CK contactors always provided with one auxiliary contact block BCLL11 (1NO+1NC)

The electronic module has been designed to support customer request to succeed in the most demanding applications. The new electronic module redesign from GE provides much better reliability versus any previous electronic modules or pure mechanical systems. This will help customer to reduce production shortages and maintenance downtimes to a minimum.

Standards

IEC/EN 60947-1	CSA 22.2/14
IEC/EN 60947-4-1	CENELEC HD 419
IEC/EN 60947-5-1	NFC 63-110
EN 50005	ASE 1025
UL 508	UNE 20109
NEMA ICS 1	VDE 0660/102
BS 5424 & 775	

- Increases mechanical life of the contactor improving reliability of end customer equipment
- Self-protecting software to avoid chattering and coil burn
- Energy efficiency: reduce on hold consumption
- Suitable for weak networks application thanks to its super wide voltage range
- Better performance in high vibration application; wind, marine, transportation
- Increased contact pressure reduces resistance per phase and thermal load
- Noise reduction even in hard environments with dust and corrosion
- Transient voltage suppressor built-in
- Wider temperature range operation: -40° to +70°C
- Application up to 3000m without de-rating: Important for Wind application
- Conversion kit for installed CK base with electronic module
- Compliant with REACH and RoHS directives

Approvals/Marking



24-60V (AC 50/60Hz and DC):

With special reinforce of the lower range (-30%) solving typical application issues when using big contactors with 24V supply.

48-130V (AC 50/60Hz and DC):

Covers the most common voltages used in transportation segment with only one contactor.

**100-250V
(AC 50/60Hz and DC):** This range replaces the most popular automation voltages; 110-120VAC, 125VDC (MV application) and 220-240VAC. Allowing OEM, Distributors and PB to optimize their stocks and service end customer.

**250-500V
(AC 50/60Hz and DC):** Typical voltage for Power Switching application. This contactor helps OEM in UPS, Data Centers and Power Quality application to standardize their machines to be sold WorldWide.

- Order codes ● page A.49
- Accessories & Spares ● page A.50
- Aux. contact blocks ● page A.51
- Technical data ● page A.99
- Dimensions ● page A.126



Three pole contactors

Max. operating current		Admissible power AC3					Electr. endurance	Control circuit AC				Control circuit AC/DC			
Not inductive load AC1 A	Motor <480V, 3~ AC3 A	220-240V	380-415V	440-480V	550-600V	690V	Cat. AC3 oper.	AC		Cat. no.	Ref. no.	AC/DC	Cat. no.	Ref. no.	
		kW hp	kW hp	kW hp	kW hp	50Hz		60Hz							
250	150	45	75			100	1.7x10 ⁶	110	120	CK75CA311J	113103	24-60	CK75CE311W24-60	246150	
								220-230	277	CK75CA311N		133188	48-130	CK75CE311W48-130	246151
		50	100	100	125			380-400	480	CK75CA311U		113105	100-250	CK75CE311W100-250	246152
								500	600	CK75CA311Y		113122	250-500	CK75CE311W250-500	246153
250	195	55	110			132	1.2x10 ⁶	110	120	CK08CA311J	113133	24-60	CK08CE311W24-60	246154	
								220-230	277	CK08CA311N		133187	48-130	CK08CE311W48-130	246155
		60	125	125	125			380-400	480	CK08CA311U		113135	100-250	CK08CE311W100-250	246156
								500	600	CK08CA311Y		101047	250-500	CK08CE311W250-500	246157
315	250	75	132			200	1.7x10 ⁶					24-60	CK09BE311W24-60	246162	
		75	150	150	150					48-130		CK09BE311W48-130	246163		
450	309	90	160			250	1.5x10 ⁶					100-250	CK09BE311W100-250	246164	
		100	250	250	300					250-500		CK09BE311W250-500	246165		
600	420	132	200			375	1.1x10 ⁶					24-60	CK95BE311W24-60	246166	
										48-130		CK95BE311W48-130	246167		
										100-250		CK95BE311W100-250	246168		
										250-500		CK95BE311W250-500	246169		
700	550	160	310			450	1x10 ⁶					24-60	CK10CE311W24-60	246170	
										48-130		CK10CE311W48-130	246171		
										100-250		CK10CE311W100-250	246172		
										250-500		CK10CE311W250-500	246173		
1000	720	200	400			500	0.8x10 ⁶					24-60	CK11CE311W24-60	246174	
										48-130		CK11CE311W48-130	246175		
										100-250		CK11CE311W100-250	246176		
										250-500		CK11CE311W250-500	246177		
1250	825	250	400			550	0.7x10 ⁶					24-60	CK12BE311W24-60	246178	
										48-130		CK12BE311W48-130	246179		
										100-250		CK12BE311W100-250	246180		
										250-500		CK12BE311W250-500	246181		
100-130	208-260	380-440	480-500					100-130	100-130	CK13BA311J	104523				
				208-260	208-260			CK13BA311N	104524						
				380-440	380-440			CK13BA311U	104525						
				480-500	480-500			CK13BA311Y	104526						

AC spare coils for 3 phase contactors

Use with	AC Voltage	Cat. No.	Ref. No.
CK75CA3...CK08CA3	110V 50Hz 120V 60Hz	C12168J	104893
	220-230V 50Hz 277V 60Hz	C12168N	104894
	380-400V 50Hz 480V 60Hz	C12168U	113888
CK13BA3...	500V 50Hz 600V 60Hz	C12168Y	133838
	100-130V 50/60 Hz	C08998J	104833
	208-260V 50/60 Hz	C08998N	104834
	380-440V 50/60 Hz	C08998U	104835
	480-500V 50/60 Hz	C08998Y	110545

Spare part and conversion kit: electronic module and coil

3 poles	24-60V		48-130V	
	Cat. No.	Ref. No.	Cat. No.	Ref. No.
CK75CE311	KKIT4E24-60	246130	KKIT4E48-130	246131
CK08CE311	KKIT4E24-60	246130	KKIT4E48-130	246131
CK85BE311	KKIT5E24-60	246134	KKIT5E48-130	246135
CK09BE311	KKIT5E24-60	246134	KKIT5E48-130	246135
CK95BE311	KKIT5E24-60	246134	KKIT5E48-130	246135
CK10CE311	KKIT7E24-60	246138	KKIT7E48-130	246139
CK11CE311	KKIT7E24-60	246138	KKIT7E48-130	246139
CK12BE311	KKIT8E24-60	246142	KKIT8E48-130	246143
	100-250V		250-500V	
CK75CE311	KKIT4E100-250	246132	KKIT4E250-500	246133
CK08CE311	KKIT4E100-250	246132	KKIT4E250-500	246133
CK85BE311	KKIT5E100-250	246136	KKIT5E250-500	246137
CK09BE311	KKIT5E100-250	246136	KKIT5E250-500	246137
CK95BE311	KKIT5E100-250	246136	KKIT5E250-500	246137
CK10CE311	KKIT7E100-250	246140	KKIT7E250-500	246141
CK11CE311	KKIT7E100-250	246140	KKIT7E250-500	246141
CK12BE311	KKIT8E100-250	246144	KKIT8E250-500	246145



Four pole contactors

Max. operating current	Admissible Power							Electr. endurance	Control circuit AC				Control circuit AC/DC		
	AC3		AC1						Cat. AC3 oper.	AC	AC	Cat. no.	Ref. no.	AC/DC	Cat. no.
Not inductive load AC1	380V 415V	220V 240V	380V 415V	440V 480V	550V 600V	690V	50Hz	60Hz							
A	A	kW	kW	kW	kW	kW									
200	55	105	76	131	143	173	228	1x10 ⁶	110	120	CK07BA411J	104533	24-60	CK07BE411W24-60	246182
									220-230	277	CK07BA411N	104534	48-130	CK07BE411W48-130	246183
									380-400	480	CK07BA411U	104535	100-250	CK07BE411W100-250	246184
350	100	185	123	214	233	281	371	0.6x10 ⁶	500	600	CK07BA411Y	110337	250-500	CK07BE411W250-500	246185
									110	120	CK08BA411J	104543	24-60	CK08BE411W24-60	246186
									220-230	277	CK08BA411N	104544	48-130	CK08BE411W48-130	246187
400	132	250	152	263	287	346	457	0.6x10 ⁶	380-400	480	CK08BA411U	104545	100-250	CK08BE411W100-250	246188
									500	600	CK08BA411Y	107244	250-500	CK08BE411W250-500	246189
									24-60						
500	160	309	191	329	359	415	572	0.6x10 ⁶	24-60				24-60	CK09BE411W24-60	246190
									48-130				48-130	CK09BE411W48-130	246191
									100-250				100-250	CK09BE411W100-250	246192
600	220	408	228	395	431	519	686	0.5x10 ⁶	250-500				250-500	CK09BE411W250-500	246193
									24-60				24-60	CK95BE411W24-60	246194
									48-130				48-130	CK95BE411W48-130	246195
700	280	530	266	460	503	606	800	0.4x10 ⁶	100-250				100-250	CK95BE411W100-250	246196
									250-500				250-500	CK95BE411W250-500	246197
									24-60				24-60	CK10CE411W24-60	246198
1000	375	680	381	658	719	866	1143	0.4x10 ⁶	48-130				48-130	CK10CE411W48-130	246199
									100-250				100-250	CK10CE411W100-250	246200
									250-500				250-500	CK10CE411W250-500	246201
1250	450	800	476	822	898	1082	1428	0.6x10 ⁶	24-60				24-60	CK11CE411W24-60	246202
									48-130				48-130	CK11CE411W48-130	246203
									100-250				100-250	CK11CE411W100-250	246204
1000	375	680	381	658	719	866	1143	0.4x10 ⁶	250-500				250-500	CK11CE411W250-500	246205
									24-60				24-60	CK12BE411W24-60	246206
									48-130				48-130	CK12BE411W48-130	246207
1000	375	680	381	658	719	866	1143	0.4x10 ⁶	100-250				100-250	CK12BE411W100-250	246208
									250-500				250-500	CK12BE411W250-500	246209
									100-130	100-130	CK13BA411J	104603			
1000	375	680	381	658	719	866	1143	0.4x10 ⁶	208-260	208-260	CK13BA411N	104604			
									380-440	380-440	CK13BA411U	104605			
									480-500	480-500	CK13BA411Y	107243			

Spare part and conversion kit: electronic module and coil

4 poles	24-60V		48-130V		
	Cat. No.	Ref. No.	Cat. No.	Ref. No.	
CK07BE411	KKIT5E24-60	246134	KKIT5E48-130	246135	
CK08BE411	KKIT8E24-60	246142	KKIT8E48-130	246143	
CK09BE411	KKIT8E24-60	246142	KKIT8E48-130	246143	
CK95BE411	KKIT8E24-60	246142	KKIT8E48-130	246143	
CK10CE411	KKIT7E24-60	246138	KKIT7E48-130	246139	
CK11CE411	KKIT7E24-60	246138	KKIT7E48-130	246139	
CK12BE411	KKIT8E24-60	246142	KKIT8E48-130	246143	
		100-250V		250-500V	
CK07BE411	KKIT5E100-250	246136	KKIT5E250-500	246137	
CK08BE411	KKIT8E100-250	246144	KKIT8E250-500	246145	
CK09BE411	KKIT8E100-250	246144	KKIT8E250-500	246145	
CK95BE411	KKIT8E100-250	246144	KKIT8E250-500	246145	
CK10CE411	KKIT7E100-250	246140	KKIT7E250-500	246141	
CK11CE411	KKIT7E100-250	246140	KKIT7E250-500	246141	
CK12BE411	KKIT8E100-250	246144	KKIT8E250-500	246145	

AC spare coils for 4 phase contactors

Use with	AC Voltage	Cat. No.	Ref. No.
CK07BA4...	110V 50Hz 120V 60Hz	C04255J	104813
CK07BA4...	220-230V 50Hz 277V 60Hz	C04255N	104814
CK07BA4...	380-400V 50Hz 480V 60Hz	C04255U	104815
CK07BA4...	500V 50Hz 600V 60Hz	C04255Y	110513
CK08BA4...	110V 50Hz 120V 60Hz	C04787J	104823
CK08BA4...	220-230V 50Hz 277V 60Hz	C04787N	104824
CK08BA4...	380-400V 50Hz 480V 60Hz	C04787U	104825
CK08BA4...	500V 50Hz 600V 60Hz	C04787Y	110529
CK13BA4...	110V 50Hz 120V 60Hz	C08998J	104833
CK13BA4...	220-230V 50Hz 277V 60Hz	C08998N	104834
CK13BA4...	380-400V 50Hz 480V 60Hz	C08998U	104835
CK13BA4...	500V 50Hz 600V 60Hz	C08998Y	110545

Auxiliary instantaneous contact block



Side mounting

Number of contacts	Contacts				Cat. no.	Ref. no.	Pack
	•3 •4	•1 •2	•7 •8	•5 •6			
2	2	0	0	0	BCLL20	104706	10
2	1	1	0	0	BCLL11	104707	10
Combinations of more than 2 blocks							
2	2	0	0	0	BRLL20	104704	10
2	1	1	0	0	BRLL11	104705	10
2	0	2	0	0	BRLL02	106622	10

Accessories

Transient voltage suppressor



For use with:	Suppressor type	Voltage	Ue	Cat. no.	Ref. no.	Pack
Fixation to the coil terminals, that allows simultaneous use with the auxiliary contact blocks.						
CK75CA...CK08CA	RC	AC	24V - 48V	BSLR3G	104716	10
CK75CA...CK08CA	RC	AC	50V - 127V	BSLR3K	104717	10
CK75CA...CK08CA	RC	AC	130V - 240V	BSLR3R	104718	10
CK75CA...CK08CA	Varistor	AC/DC	227V - 500V	BSLV3U	110836	10
CK07BA, CK08BA and CK13BA	RC	AC	24V	KRC24	104760	10
CK07BA, CK08BA and CK13BA	RC	AC	260V	KRC48/260	104761	10
CK07BA, CK08BA and CK13BA	RC	AC	415V	KRC380/415	104762	10
Only for CSA market						
CK75CE	Varistor	250-500	AC/DC	BSLV4U	204895	10
CK08CE-CK12BE	Varistor	250-500	AC/DC	BSLV5U	204896	10

Mechanical interlock



	Mounting					
CK07B ... CK12	Horizontal			BEKH	104763	1
CK07B ... CK95	Vertical			BEKVS 1	104786	1
CK10C ... CK12B	Vertical			BEKVA 1	104785	1
CK13	Vertical			BEKV	104764	1

Pole terminal protection

CK75C ... CK08C	1 pole. VDE0106			CM1CA5F	105200	1
CK85B ... CK12B	1 pole. VDE0106	Contactors 3P		C09476	104766	6
CK08B ... CK12B	1 pole. VDE0106	Contactors 4P		C09479	204800	8
CK75C ... CK08C	1 pole IPXXB			PTPCK75	103747	1 ⁽¹⁾
CK85B ... CK95B	1 pole IPXXB			PTPCK95	103748	3 ⁽²⁾
CK10C ... CK12B	1 pole IPXXB			PTPCK11	103749	1 ⁽¹⁾

(1) One phase
(2) Three pole

Spares

Contact kits



For use with:	Type		Cat. no.	Ref. no.	Pack
One set consists of two fixed contacts, one moving contact and accessory parts.					
When contact replacement is needed, it is recommended to replace all the contacts at the same time.					
CK07B	NA		V1107BA	113612	1
CK75C	NA		V1175CA	113613	1
CK08C	NA		V1108CA	113614	1
CK08B	NA	Contactors 4P	V1108B4	113505	1
CK85B	NA		V1185BA	113615	1
CK09B	NA		V1109BA	113616	1
CK09B	NA	Contactors 4P	V1109B4	113899	1
CK95B	NA		V1195BA	113617	1
CK10C	NA		V1110CE	113618	1
CK11C	NA		V1111CE	113619	1
CK12B	NA		V1112BA	113620	1
CK13B	NA		V1113BA	113621	1

Order codes

Intro

A

B

C

D

E

F

G

H

I

X



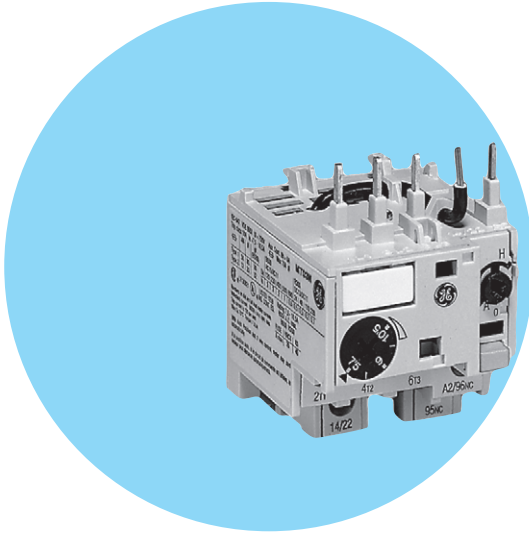

Thermal overload relays for contactors from 0.11 to 14A

- Control circuit up to 690V
- Power circuit up to 690V
- Three-pole differential (phase unbalance protection)
- Automatic ambient temperature compensation between -25°C and +60°C
- Choice of manual or automatic reset
- Direct connection to contactor or independent mounting using accessories.
- Screw and Ring terminal versions
- Terminals protected against accidental contact in accordance with VDE 0106 T.100 and VBG4.
- Terminal numbering in accordance with EN 50005
- Degree of protection IP20 (EN 60529)

Standards

IEC/EN 60947-4-1	CSA 22.2/14
IEC/EN 60947-5-1	NI C 63-650
UNE 115	VDE 0660
NFC 63-650	UL 508

General characteristics

- Thermal protection against balanced overload.
- Three-pole differential (phase unbalance protection).
- Automatic ambient temperature compensation.
- Front mounted selector for choosing utilisation current.
- Reset button, 2 positions :
Manual(H) and Automatic(A) by turning the blue selector.
- Stop push button, independent of reset (red).
- Manual trip lever (tripping test).
- Tripping indicator (0-1).
- To facilitate wiring arrangements terminal 96 fits directly onto coil terminal (A2) and terminal 14/22 fits directly onto the feedback auxiliary contact.

Approvals/Marking





Order codes ● page A.53
 Technical data ● page A.130
 Dimensions ● page A.131



Thermal overload relays for contactors

	For use with:	Setting range (regulation)		Fuse				Terminal: screw		Terminal: ring terminal		Pack
				aM		gL		Cat. no.	Ref. no.	Cat. no.	Ref. no.	
				Type 2	Type 1	Type 2	Type 1					
	MC0...	0.11	0.17	0.5	0.5	0.5	0.5	MT03A	101000	MT03RA	103540	10
	MC1...	0.17	0.26	0.85	1	1	1	MT03B	101001	MT03RB	103541	10
	MC2...	0.26	0.43	1	2	2	4	MT03C	101002	MT03RC	103542	10
		0.43	0.65	1	4	2	8	MT03D	101003	MT03RD	103543	10
		0.65	1	2	6	4	12	MT03E	101004	MT03RE	103544	10
		0.85	1.3	2	6	4	12	MT03F	101005	MT03RF	103545	10
		1.1	1.6	2	10	4	16	MT03G	101006	MT03RG	103546	10
		1.35	2	4	10	6	16	MT03H	101007	MT03RH	103547	10
		1.7	2.4	4	16	6	25	MT03I	101008	MT03RI	103548	10
		2.2	3.2	4	20	6	32	MT03J	101009	MT03RJ	103549	10
		2.5	4	4	20	6	32	MT03R	101015			10
		3	4.7	6	20	10	32	MT03K	101010	MT03RK	103550	10
		4	6.3	10	32	16	50	MT03L	101011	MT03RL	103551	10
		5.5	8	12	50	20	63	MT03M	101012	MT03RM	103552	10
		7.5	10.5	16	50	25	80	MT03N	101013	MT03RN	103553	10
		10	14	20	32	32	100	MT03P	101014	MT03RP	103554	10

Accessories

		Terminal	Cat. no.	Ref. no.	Pack	
	Input terminals	Screw	MVE0T	101020	5	
		Ring terminal	MVE0R	103562	5	
	Base	For separate mounting onto standard EN 50022-35 profile	MVB0T	101021	5	
	Auxiliary contact block	Frontal fixing to the relay With trip indicator (0-I) One block per relay and only for manual reset	Screw Ring terminal	MATV10AT MATV10AR	101022 103563	10 10
	Identification	Sheets of labels (sheets of 260 labels each) Labeling plate base (50 pieces in one pack)	EAT 260 SPR	100548 100549	1 1	

Order codes

Intro

A

B

C

D

E

F

G

H

I

X



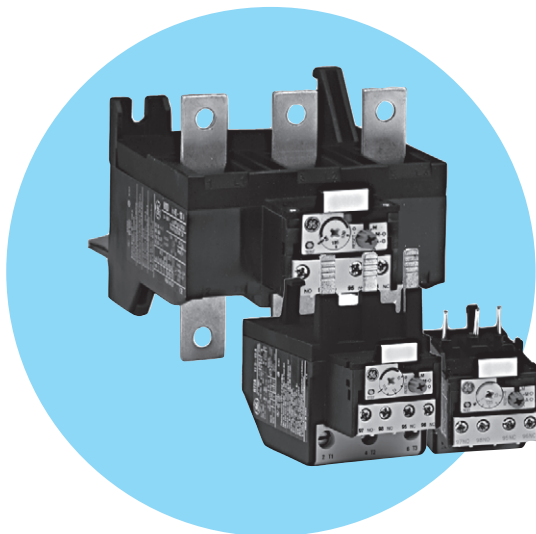

Thermal overload relays for contactors from 0.16 to 850A

- Control circuit up to 690V AC
- Power circuit:
 - RT1, RT12: up to 690V
 - RT2, RT22, RT3, RT32, RT4/4L, RT5/5L & RT6/6L: up to 1000V
- Thermal protection against normal overloads.
- Three pole differential (phase unbalance protection).
- Protection against long starting times.
- Automatic ambient temperature compensation between -25°C +60°C.
- Front mounted test button.
- Trip indication.
- Independent auxiliary contacts with double rupture (1NO + 1NC).
- Function selector:
 - Manual RESET
 - Manual RESET and STOP
 - Automatic RESET with STOP
 - Automatic RESET without STOP

Standards

IEC/EN 60947-4-1	CSA 22.2/14
IEC/EN 60947-5-1	NI C 63-650
UNE 115	VDE 0660
NFC 63-650	UL 508
CEI 17-50	

Approvals/Marking



cULus



CE



Lloyd's Register



Bureau Veritas



RINA



(Contact GE for details)

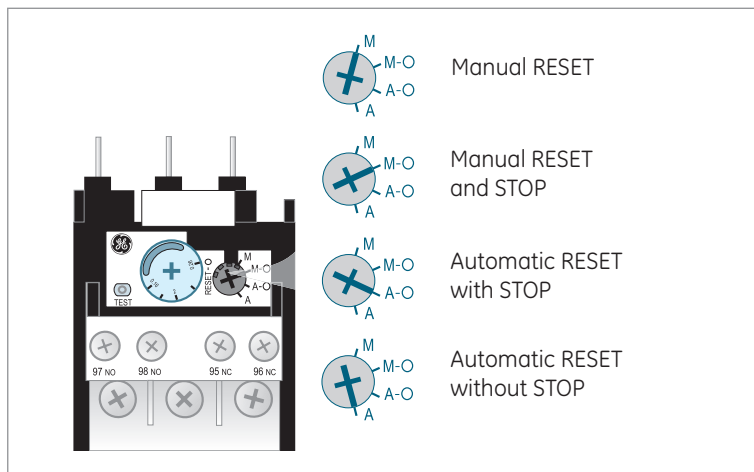

Order codes ● page A.55
 Technical data ● page A.132
 Dimensions ● page A.136





Thermal overload relays for EC contactors



Class	For use with	Setting range		Fuses ⁽¹⁾		Box clamp terminals		Pack		
		Min. A	Max. A	AM A	gL-gG A	Cat. no.	Ref. no.			
Class 10A	EC09 EC12 EC18	0.16	0.26	2	2	ECRT1B10B	268996	5		
		0.25	0.41	2	2	ECRT1B10C	268997	5		
		0.40	0.65	2	2	ECRT1B10D	268998	5		
		0.65	1.10	2	4	ECRT1B10F	268999	5		
		1.00	1.50	4	6	ECRT1B10G	269000	5		
		1.30	1.90	4	6	ECRT1B10H	269001	5		
		1.80	2.70	6	10	ECRT1B10J	269002	5		
		2.50	4.00	8	16	ECRT1B10K	269003	5		
		4.00	6.30	12	20	ECRT1B10L	269004	5		
		5.50	8.50	16	20	ECRT1B10M	269005	5		
		8.00	12.00	20	25	ECRT1B10N	269006	5		
		10.00	16.00	25	35	ECRT1B10P	269007	5		
		14.50	18.00	32	50	ECRT1B10S	269008	5		
		17.50	22.00	40	63	ECRT1B10T	269009	5		
		Class 10A	EC25 EC32 EC40	8.00	12.00	20	25	ECRT2B10N	268103	5
				10.00	16.00	25	35	ECRT2B10P	268104	5
				14.50	18.00	32	50	ECRT2B10S	268105	5
17.50	22.00			40	63	ECRT2B10T	268106	5		
21.00	26.00			40	63	ECRT2B10U	268107	5		
25.00	32.00			50	80	ECRT2B10V	268108	5		
30.00	40.00			63	100	ECRT2B10W	268109	5		

Thermal overload relays for contactors

Class	For use with	Setting range (regulation)		Fuses ⁽¹⁾		Screw terminal		Ring terminal		Pack
		Min. A	Max. A	AM A	gL-gG A	Cat. no.	Ref. no.	Cat. no.	Ref. no.	
Class 10A	CL00 CL01 CL02 CL03 CL04 CL05	0.16	0.26	2	2	RT1B	113700	RT1RB	114087	5
		0.25	0.41	2	2	RT1C	113701	RT1RC	114131	5
		0.4	0.65	2	2	RT1D	113702	RT1RD	114089	5
		0.65	1.1	2	4	RT1F	113703	RT1RF	114090	5
		1.0	1.5	4	6	RT1G	113704	RT1RG	114091	5
		1.3	1.9	4	6	RT1H	113705	RT1RH	114092	5
		1.8	2.7	6	10	RT1J	113706	RT1RJ	114093	5
		2.5	4.1	8	16	RT1K	113707	RT1RK	114094	5
		4.0	6.3	12	20	RT1L	113708	RT1RL	114095	5
		5.5	8.5	16	20	RT1M	113709	RT1RM	114096	5
		8.0	12.0	20	25	RT1N	113710	RT1RN	114097	5
		10.0	16.0	25	35	RT1P	113711	RT1RP	114098	5
		14.5	18.0	32	50	RT1S	113712	RT1RS	114099	5
		17.5	22.0	40	50	RT1T	113713	RT1RT	114100	5
		21.0	26.0	40	63	RT1U	113714	RT1RU	114101	5
		25.0	32.0	50	80	RT1V	113715	RT1RV	114102	5
		30.0	40.0	63	100	RT1W	113716	RT1RW	114103	5
Class 10	CL07 CL08 CL09 CL10 EF50 EF65 EF80 EF95 EF105	11.5	15.0	32	35	RT2A	113717	RT2RA	114104	1
		14.5	19.0	40	50	RT2B	113718	RT2RB	114132	1
		18.5	25.0	50	63	RT2C	113719	RT2RC	114106	1
		24.0	32.0	63	100	RT2D	113720	RT2RD	114133	1
		30.0	43.0	80	125	RT2E	113721	RT2RE	114134	1
		42.0	55.0	100	160	RT2G	113722	RT2RG	114109	1
		54.0	65.0	125	160	RT2H	113723	RT2RH	114146	1
		64.0	82.0	125	200	RT2J	113724	RT2RJ	114136	1
		78.0	97.0	125	200	RT2L	113725	RT2RL	114235	1
		90.0	110	160	250	RT2M	113726	RT2RM	114113	1

(1) Most suitable fuse in accordance with IEC 60947-4-1.

(continued on page A.56)



Thermal overload relays for contactors (continued)



	For use with:	Setting range (regulation)		Fuses ⁽¹⁾		Screw terminal		Pack	
		Min. A A	Max. A A	AM A	gL-GG A	Cat. no.	Ref. no.		
Class 10	CK75 CK08 Direct mounting	55	80	125	200	RT3B	113727	1	
		63	90	125	200	RT3C	113728	1	
		90	120	160	250	RT3D	113729	1	
		110	140	200	315	RT3E	113730	1	
		140	190	250	355	RT3F	113731	1	
	CK85 CK09 CK95 ⁽²⁾	120	190	250	315	RT4N	113732	1	
		175	280	315	400	RT4P	113733	1	
		200	310	400	500	RT4R	113734	1	
	CK10 CK11 CK12 ⁽²⁾	120	190	250	315	RT5A	113750	1	
		175	280	315	400	RT5B	113751	1	
		250	400	500	630	RT5C	113752	1	
		315	500	630	800	RT5D	113753	1	
		430	700	800	1000	RT5E	113754	1	
	CK13	500	850	100	1250	RT6A	113760	1	
	Class 20	CK75 CK08 Direct mounting	63	90	125	200	RT32C	113657	1
90			120	160	250	RT32D	113658	1	
110			140	200	315	RT32E	113659	1	
140			190	250	355	RT32F	113660	1	
Class 30	CL... CK... Mounting with screws	2.5	4	10	16	RT4LA	113735	1	
		4	6.5	12	20	RT4LB	113736	1	
		5.5	8.5	16	25	RT4LC	113737	1	
		7.5	11	20	32	RT4LD	113738	1	
		10	16	25	40	RT4LE	113739	1	
		12.5	20	32	50	RT4LF	113740	1	
		17	27	50	80	RT4LG	113741	1	
		26	40	80	125	RT4LH	113742	1	
		32	52	100	160	RT4LJ	113743	1	
		45	70	125	160	RT4LK	113744	1	
		60	90	160	200	RT4LL	113745	1	
		80	125	200	250	RT4LM	113746	1	
		CK85	120	190	250	315	RT4LN	113747	1
		CK09	175	280	315	400	RT4LP	113748	1
		CK95 ⁽²⁾	200	310	400	500	RT4LR	113749	1
	CK10 CK11 CK12 ⁽²⁾	120	190	250	315	RT5LA	113755	1	
		175	280	315	400	RT5LB	113756	1	
		250	400	500	630	RT5LC	113757	1	
		315	500	630	800	RT5LD	113758	1	
		430	700	800	1000	RT5LE	113759	1	
CK13	500	850	1000	1250	RT6LA	113761	1		

(1) Most suitable fuse in accordance with IEC 60947-4-1.

(2) Fitting direct to the contactor: by means of a coupling and connection set.

Accessories



Use with	Description	Cat. no.	Ref. no.	Pack
Base for separate mounting				
ECRT1	DIN EN50022-35	ECRT1BS	268963	1
ECRT2	DIN EN50022-35	ECRT2BS	268964	1

RT1	DIN EN50022-35	RTXP	105170	1
RT2	DIN EN50022-35	RT2XP	113764	1

Setting range cover protection	RT...	RTX3	113762	1
--------------------------------	-------	------	--------	---

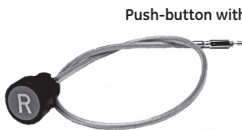

Push-button with flexible cable	for distance RESET				
	RT1... - RT6... (front)	0,5 meters	RTXS	113855	1
	RT1... - RT6... (front)	1 meters	RTXSL	113856	1
	RT1..., RT2..., RT4..., RT5..., RT6... (back)		RTXBS	108864	1

Terminal protection	for RT3 or CK75C/CK08C			
	Thermal overload relay	pole IPxxB	PTPCK75	103747



Remote electrical reset	RT1... - RT6...	RTXRR ♦	-	1
-------------------------	-----------------	---------	---	---

Available coil voltages (V)

♦	B	D	G	J	N	U	X
AC/DC	12	24	48	110	220	380	440
				240	415	480	

Order codes

Intro

A

B

C

D

E

F

G

H

I

X



Electronic overload relays



Approvals/Marking



Product features

Lower power consumption
 Great accuracy
 Full reliability
 Phase unbalance protection
 Direct fitting to contactors Series CL
 Interchangeable with thermal overload relay
 Multiple trip class selection
 Manual / Auto reset

Your benefits

- Saving space into cabinet
- Better motor protection
- Low risk to burn motor
- Better motor protection and current control
- Compact starter
- No need to redesign existing cabinet
- One device cover for start time motor
- One device for two solutions



Main characteristics

- Setting range from 0.1 up to 150A
- Self powered
- Thermal memory
- Phase loss protection
- Phase unbalance protection
- Direct fitting to contactors Series CL
- Interchangeable with thermal overload relay
- Multiple trip class selection
- Manual / Auto reset
- Increased flexibility, less order codes, less stock
- Trip class: 5 - 10 - 20 - 30



Order codes ● page A.59
 Dimensions ● page A.138



Electronic overload relays for contactors

	Suitable for	Setting range (A)		Fuses (A) ⁽¹⁾	Cat. no.	Ref. no.	Pack.
		Min.	Max.	gL - gG			
	Frame 1 CL00...CL05	0.1	0.5	2	RE1D	101866	5
		0.4	2	4	RE1H	101867	5
	EC09...EC40	1.0	5	10	RE1K	101868	5
		1.6	8	20	RE1M	101869	5
		6.4	32	63	RE1S	101870	5
		9.0	45	80	RE1W	101871	5
		22	110	125	RE2M	101873	1
Frame 2 CL07...CL10 EF50...EF105	15	75	125	RE2H	101872	1	
	22	110	125	RE2M	101873	1	
	Frame 3 CK75-CK08	30	150	250	RE3E	101874	1

Accessories

	Use with	Cat. no.	Ref. no.	Pack.
Transparent cover for pushbutton reset	For frames 1, 2 and 3	RETC	247795	10
	Independent mounting base adaptor Frame 1	RE1XP	247302	1
	Independent mounting base adaptor Frame 2	RE2XP	247303	1
	Use with	Cat. no.	Ref. no.	Pack.
	Push-button with flexible cable			
	Front - 0.5 m	RTXS	113855	1
	Front - 1 m	RTXSL	113856	1
Back	RTXBS	108864	1	

(1) Most suitable fuse in accordance with IEC 60947-4-1, see coordination table on pg. A.142.

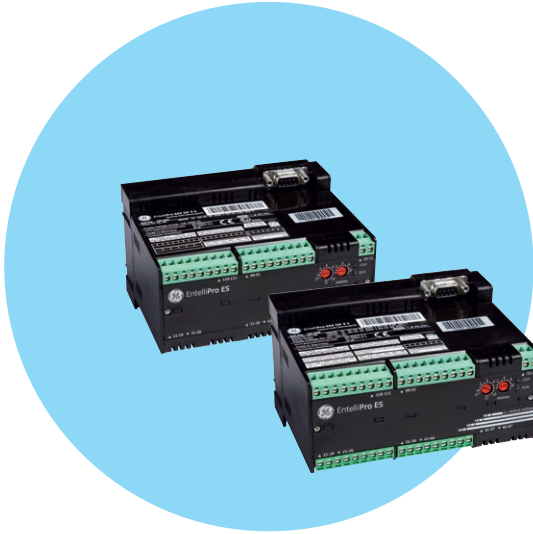

Intelligent motor management relay EntelliPro ES3 / ES5

- Motor protection and motor control
- Pre-programmed motor typicals
- Communication Interface to Profibus-DP and Modbus RTU system
- Status information from motor and switchgear
- Maintenance information,
- Management of settings and configuration
- Predefined control logic
- Local control and display devices

Protection

- Overload (Class 5 to 40)
- Earth fault (Residual current))
- Phase loss
- Thermistor (PTC)
- Start current
- Blocked rotor
- Under load
- Maximum starts per time
- Self monitoring
- External device monitoring

Diagnostic

- Time to overload trip, release
- Number of operations
- Number of motor starts
- Motor ON-time, OFF-time
- Number of overload trips
- Number of thermistor trips
- Maximum currents
- Trip currents

Drive typicals

- Direct-on-line
- Reverse
- Star delta
- Star delta reverse
- Softstarter
- Softstarter reverse
- Dahlander
- Pole changing starter
- Solenoid valve
- Actuator

Approvals/Marking



SIL certified



ATEX certified



CE

Order information

EntelliPro ES3 DP 2 2

ES3 = Standard device
ES5 = Medium device

2 = Power supply and 7 digital inputs, voltage 24V DC
3 = Power supply and 7 digital inputs, voltage 110-240V AC

0 = no additional 9 digital inputs available
2 = additional 9 digital input, voltage 24V DC
3 = additional 9 digital input, voltage 110-240V AC

Order codes ● page A.61
Technical data ● page A.62
Dimensions ● page A.64



Intro

A

B

C

D

E

F

G

H

I

X

Intelligent motor management relay

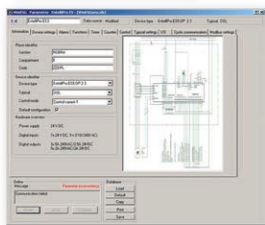

Type	Voltage	Ref. No.
Standard device (I/O 7 digital inputs / 3 digital outputs)		
EntelliPro ES3 DP 2 0	24V DC	720003
EntelliPro ES3 DP 3 0	240V AC	720004
Mid device (I/O 16 digital inputs / 8 digital outputs + 4–20mA output)		
EntelliPro ES5 DP 2 2	24V DC	720005
EntelliPro ES5 DP 2 3	Supply and 7 digital inputs 24V DC	720006
EntelliPro ES5 DP 3 3	9 digital inputs 110 - 240V DC 110 - 240V AC	720007
Transformer		
EntelliPro CT8	1,4A – 8A	720022
EntelliPro CT32	5,4A - 32A	720023
EntelliPro CT64	10,7A – 64A	720024
EntelliPro CT630	105A - 630A	720025
HMI Control panel		
EntelliPro CP3	HMI 3,3" LCD	720028
EntelliPro CP5	HMI 7" color TFT-LCD	720029
Parameterizing user software		
WinESG V3	EntelliPro software tool for Windows	720020
Profibus-DP WinESG (OPC-PB-USB)		
	Master Hardware	720037
<p>The WinESG CD, part number 720020, contains the WinESG installation file, necessary drivers, GSD file and installation information. WinESG runs on PCs with Windows 7 operating system or higher.</p> <p>To communicate to the EntelliPro devices also the Profibus-DP Master Hardware, part number 720037, is required.</p>		
Demonstration KIT		
Demo-case	Demonstration KIT for EntelliPro	720030

Order codes

Intro

A

B

C

D

E

F

G

H

I

X



Intelligent motor management relay

Overload tripping curves IEC 60947-4-1 (3-Pole / 3-Wire)

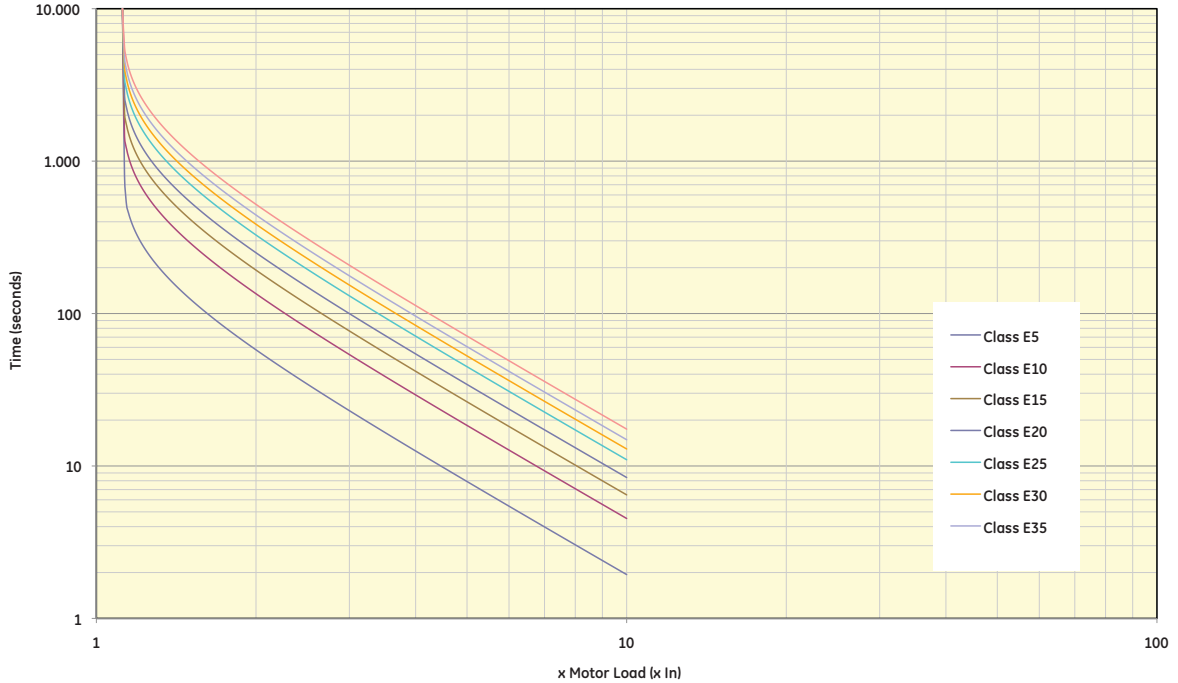

Current (x In)	Class E5 (sec)	Class E10 (sec)	Class E15 (sec)	Class E20 (sec)	Class E25 (sec)	Class E30 (sec)	Class E35 (sec)	Class E40 (sec)	Tolerance (%)
1.2	314.70	734.29	1048.99	1363.68	1783.28	2097.98	2412.67	2832.27	10
1.4	156.93	366.16	523.09	680.01	889.25	1046.17	1203.10	1412.83	10
1.6	103.43	241.33	344.75	448.18	586.08	689.50	792.93	930.83	10
1.8	75.21	175.49	250.70	325.91	426.19	501.40	576.61	676.90	10
2	57.80	134.86	192.66	250.46	327.53	385.33	443.12	520.19	10
2.5	34.41	80.29	114.70	149.11	194.99	229.40	263.81	309.69	10
3	23.26	54.10	77.85	101.91	133.65	155.70	178.76	209.50	10
3.5	16.79	39.02	56.31	73.91	97.03	112.62	129.22	151.34	10
4	12.74	29.56	42.80	56.34	74.06	85.60	98.14	114.86	10
4.5	10.02	23.22	33.74	44.56	58.66	67.48	77.30	90.40	10
5	8.11	18.75	27.36	36.26	47.81	54.71	62.62	73.16	10
5.5	6.71	15.48	22.68	30.19	39.86	45.37	51.87	60.55	10
6	5.65	13.01	19.10	24.31	31.97	37.52	43.16	50.43	10
6.5	4.83	11.10	16.43	20.76	27.33	32.06	36.89	43.06	10
7	4.18	9.59	13.40	17.96	23.67	27.76	31.94	37.25	10
7.2	3.90	9.08	12.78	17.00	22.42	26.28	30.25	35.26	10
8	3.20	7.39	10.40	13.88	18.33	21.47	24.71	28.76	20
9	2.60	5.89	8.40	11.09	14.68	17.18	18.90	22.98	20
10	2.30	5.20	7.40	9.10	12.19	14.13	16.27	18.85	20



Overload tripping curves IEC 60947-4-1 (2-Pole / 2-Wire)

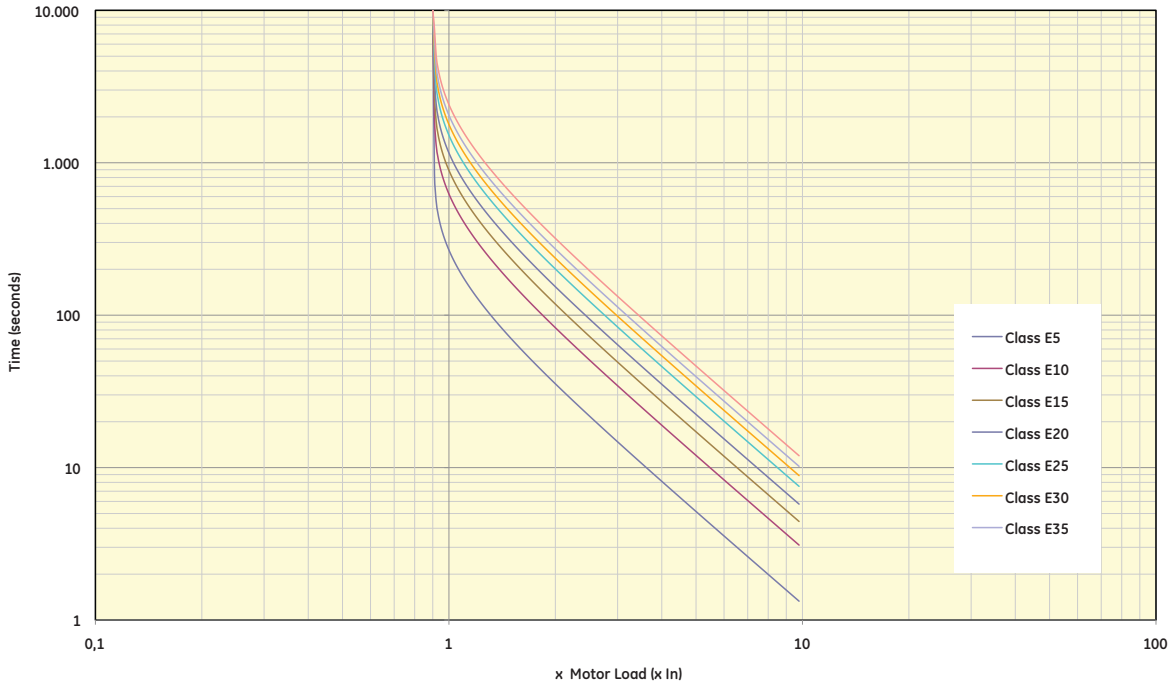

Current (x In)	Class E5 (sec)	Class E10 (sec)	Class E15 (sec)	Class E20 (sec)	Class E25 (sec)	Class E30 (sec)	Class E35 (sec)	Class E40 (sec)	Tolerance (%)
1	267.42	623.99	891.41	1158.83	1515.39	1782.81	2050.24	2406.80	10
1.2	130.59	304.72	435.31	565.91	740.03	870.63	1001.22	1175.35	10
1.4	83.87	195.69	279.56	263.43	475.25	559.12	642.98	754.81	10
1.6	59.72	139.35	199.07	258.79	338.42	398.14	457.88	537.48	10
1.8	45.12	105.27	150.39	195.51	255.67	300.78	345.90	406.06	10
2	35.46	82.75	118.21	153.67	200.96	236.42	271.88	319.17	10
2.5	21.73	50.71	72.45	94.18	123.16	144.90	166.63	195.61	10
3	14.76	34.44	49.20	63.97	83.65	98.41	113.17	132.85	10
3.5	10.70	24.98	35.68	46.39	60.66	71.36	82.07	96.34	10
4	8.13	18.97	27.09	35.22	46.06	54.19	62.32	73.15	10
4.5	6.39	14.90	21.29	27.67	36.19	42.57	48.96	57.48	10
5	5.15	12.02	17.17	22.33	29.20	34.35	39.50	46.37	10
5.5	4.25	9.91	14.15	18.40	24.06	28.30	32.55	38.21	10
6	3.56	8.31	11.86	15.42	20.17	23.73	27.29	32.04	10
6.5	3.03	7.06	10.09	13.12	17.16	20.18	23.21	27.25	10
7	2.80	6.30	8.79	11.70	15.47	17.88	20.94	24.36	10
7.2	2.60	6.05	8.42	11.09	14.66	16.92	19.83	23.07	10
8	2.20	4.90	6.80	9.14	12.09	13.78	16.22	19.04	20
9	1.75	3.80	5.66	7.21	9.61	10.98	13.00	15.05	20
10	1.66	3.50	5.30	6.39	7.87	8.98	12.19	14.01	20



Dimensional drawings

EntelliPro ES3/ES5

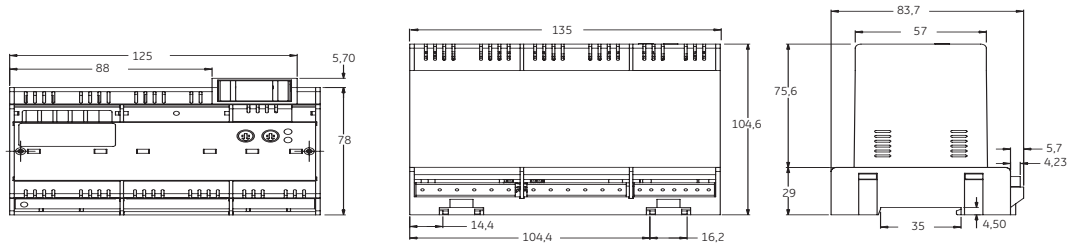

Transformers

CT 8 - CT 32 - CT 64

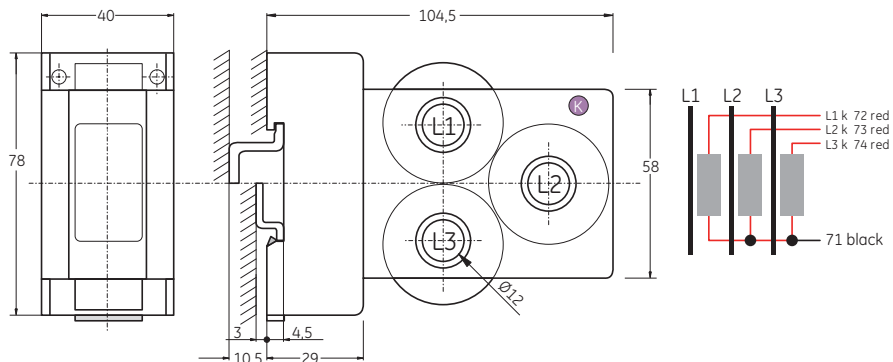

CT 630

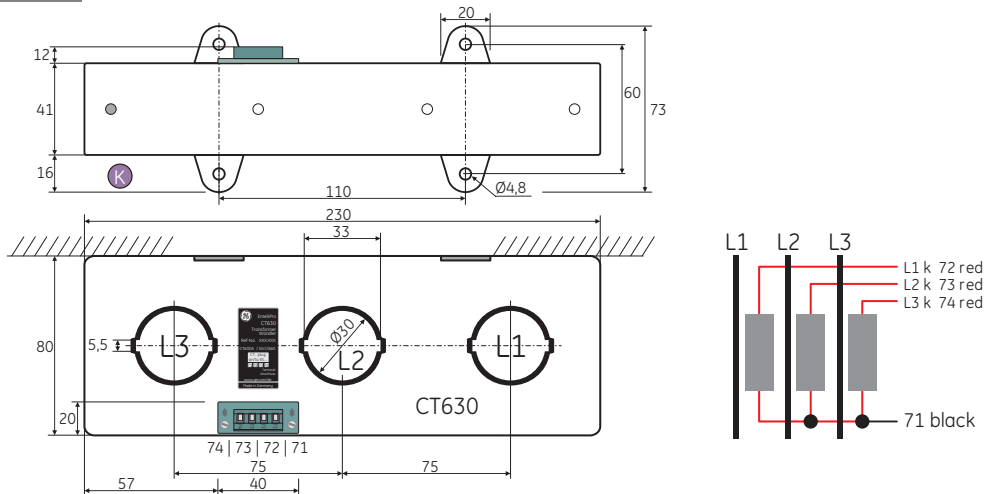

Dimensions in mm (inch = mm x 0.03937) - Weight in kg (lb = kg x 2.2046)

Control panel

CP3

Unit: mm

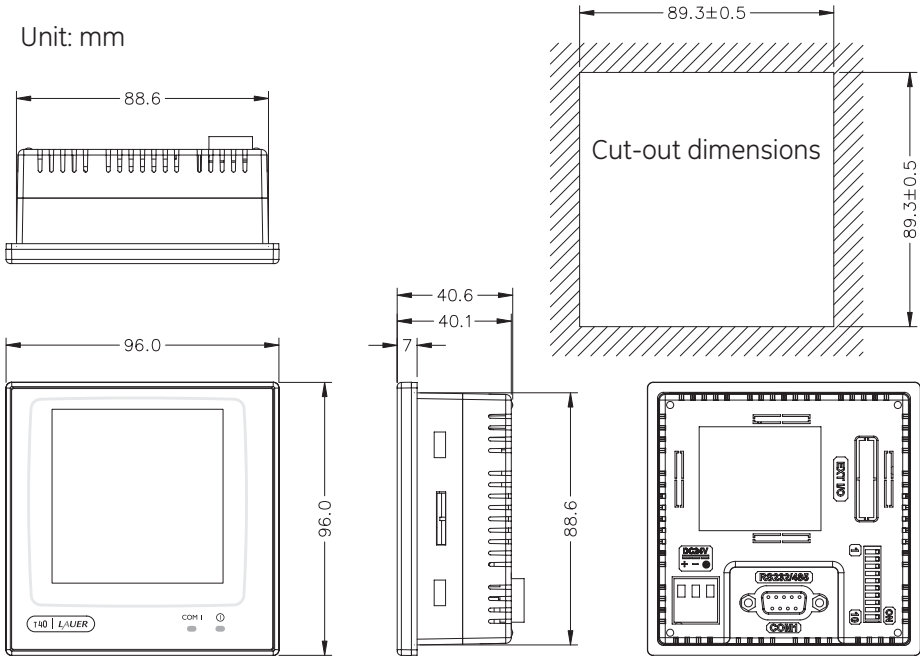

Dimensions

Intro

A

B

C

D

E

F

G

H

I

X

CP5

Unit: mm

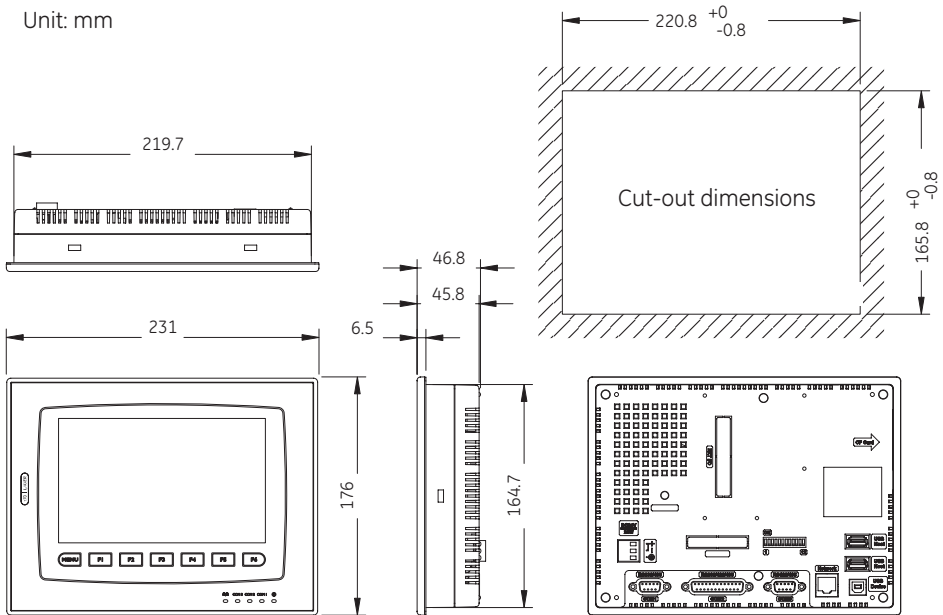

Dimensions in mm (inch = mm x 0.03937) - Weight in kg (lb = kg x 2.2046)



Conformity to standards

IEC/EN 60947-1	GB14048.4
IEC/EN 60947-4-1	UL508
IEC/EN 60947-5-1	UL486E
IEC/EN 60947-5-4	CSA2.22-14
EN50011	NF F16 101/102
EN50012	
EN50005	

Approvals/Marking



Ambient conditions

Storage temperature	-55°C to +80°C
Operation temperature	-40°C to +55°C
Without TOR	-40°C to +60°C
	-40°C to +70°C ⁽¹⁾
Altitude	<2000m

(1) From 100% to 110% of rated control voltage, no auxiliary blocks

Climatic resistance (IEC 68-2)

Continuous tests 40 / 125 / 56	
Cold (72h)	Temperature -40°C
Dry heat (96h)	Temperature +125°C Relative humidity < 50%
Humid heat (56h)	Temperature +40°C Relative humidity 95%
Cyclic test (6 cycles)	
First half-cycle	Low temperature +25°C Relative humidity 93%
Second half-cycle	Low temperature +55°C Relative humidity 95%

Mounting positions

Installation capabilities

With derating values

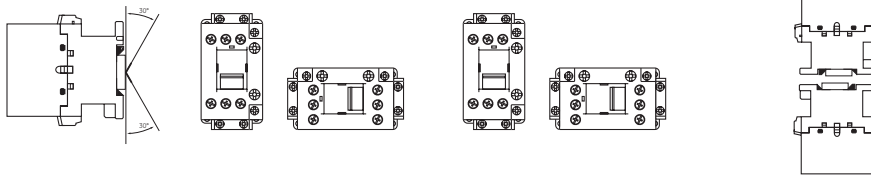

-10% connection voltage
+10% disconnection
voltage with same rated
power, data compared to
vertical mounting

Terminal capacity and tightening torque

	Conventional thermal current (Ith)	Head type	EC contactors			EF contactors	
			EC09...EC18 ECAC	EC25	EC32...EC40	EF50...EF80	EF95...EF105
	Box terminals						
	Solid, stranded and finely stranded without ferrule (mm ²)	Slot & PZ2	0.75 ... 6	0.75 ... 10	0.75 ... 16	2.5 ... 35	4 ... 50
	Finely stranded with ferrule (mm ²)	Slot & PZ2	0.75 ... 6	0.75 ... 10	0.75 ... 16	2.5 ... 35	4 ... 50
	Finely stranded without ferrule (mm ²)	Slot & PZ2	0.75 ... 6	0.75 ... 10	0.75 ... 16	2.5 ... 35	4 ... 50
	AWG		18 ... 10	18 ... 8	18 ... 6	13 ... 2	11 ... 1/0
	Tightening torque (Nm)		2.2	2.2	2.2	4-4.5	5.6-6.5
			20	20	20	35-40	50-60
	Solid (mm ²)					2.5 ... 35	4 ... 50
	Stranded (mm ²)					2.5 ... 35	4 ... 50
	Finely stranded without ferrule (mm ²)	Slot & PZ2	0.75 ... 6	0.75 ... 10	0.75 ... 16	2.5 ... 35	4 ... 50
	Finely stranded with ferrule (mm ²)					2.5 ... 35	4 ... 50
	AWG		18 ... 10	18 ... 8	18 ... 6	13 ... 2	11 ... 1/0
	Tightening torque (Nm)		2.2	2.2	2.2	4 - 4.5	5.6 - 6.5
			20	20	20	35 - 40	50 - 60
	Solid, stranded and finely stranded without ferrule (mm ²)					Max. 1x16 + 1x10	Max. 1x25 + 1x25
	Finely stranded without ferrule (mm ²)					Max. 1x16 + 1x10	-
	Finely stranded with ferrule (mm ²)	Slot & PZ2	0.75 ... 6	0.75 ... 10	0.75 ... 16	Max. 1x16 + 1x10	-
	AWG		18 ... 10	18 ... 8	18 ... 6	Max. 1x5 + 1x7	Max. 1x3 + 1x3
	Tightening torque (Nm)		2.2	2.2	2.2	4 - 4.5	5.6 - 6.5
			20	20	20	35 - 40	50 - 60

Coil Terminal capacity and tightening torque

Tightening torque		0.8Nm - 7Lb/in
Solid wire (mm ²)		0.75 to 2x2
Flexible wire without terminal (mm ²)		0.75 to 2.5x2
Flexible wire without terminal with cap (mm ²)		0.75 to 2.5x21



Electrical endurance

Category AC3 (3P contactors)

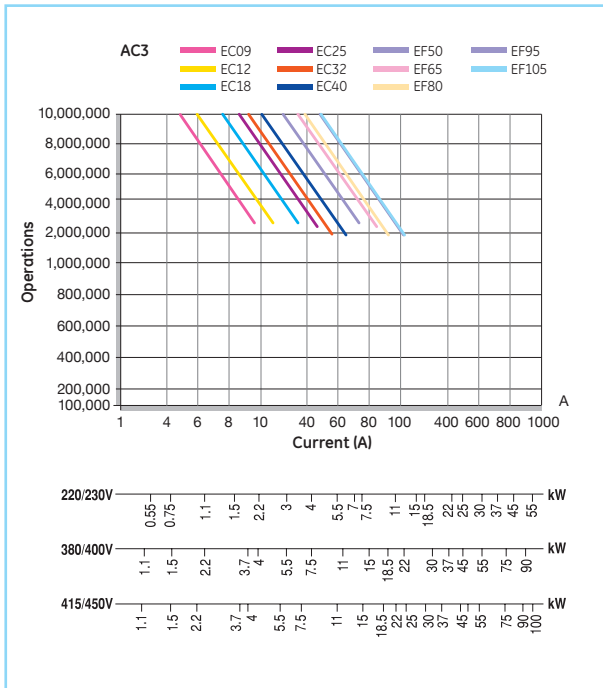

Category AC4 (3P contactors)

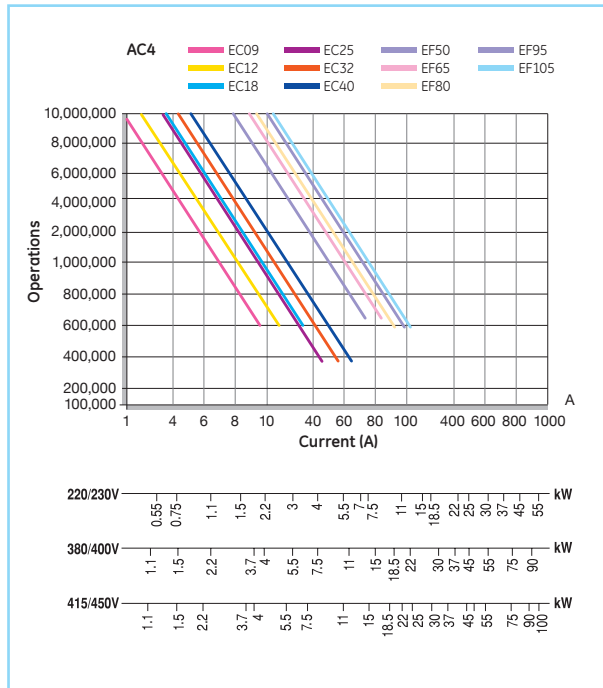

Power circuit for EC contactors

		EC 09	EC 12	EC18	EC 25	EC 32	EC 40
Three pole version							
Rated thermal current I _{th} at θ ≤ 55°C	(A)	25	25	32	45	60	60
Rated operational current I _e AC-3	(A)	9	12	18	25	32	40
Rated operational voltage U _e	(V)	690V acc. IEC 60947-4-1 / 600V acc. UL-CSA					
Four pole version							
Rated thermal current I _{th} at θ ≤ 55°C	(A)	-	25	32	45	60	-
Rated operational voltage U _e	(V)	690V acc. IEC 60947-4-1 / 600V acc. UL-CSA					
Three and four pole version							
Rated insulation voltage U _i	(V)	1000V acc. IEC 60947-4-1 / 600V acc. UL-CSA					
Maximum continuous current AC-1	(A)	25	25	32	45	60	60
Frequency limits	(Hz)	25..400	25..400	25..400	25..400	25..400	25..400
Making capacity (RMS) (IEC- 60947) U = 500V	(A)	220	220	220	315	520	520
Breaking capacity (RMS) (acc. IEC-60947)							
U _e = 500V	(A)	220	220	220	315	520	520
U _e = 690V	(A)	120	120	120	144	232	232
Short-time current from cold state							
1s	(A)	570	570	570	790	1265	1265
5s	(A)	254	254	254	355	565	565
10s	(A)	180	180	180	250	400	400
30s	(A)	104	104	104	145	231	231
1min	(A)	74	74	74	102	164	164
3min	(A)	42	42	42	60	95	95
Recovery time	(min)	10	10	10	10	10	10
Protection against short-circuit with fuses without thermal overload relay (TOR)							
Coordination type 1							
gL-gG (U = 500V, 50kA or U = 415V, 80kA)	(A)	40	40	50	63	80	80
Coordination type 2							
gL-gG (U = 500V, 50kA or U = 415V, 80kA)	(A)	25	35	40	50	63	80
Average impedance per pole	(mΩ)	2.25	2.25	2.25	1.6	1.2	1.2
Power dissipation per pole							
AC-1	(W)	1.41	1.41	2.30	3.24	4.32	4.32
AC-3	(W)	0.18	0.32	0.73	1.00	1.23	1.92
Insulation resistance							
Between adjacent poles	(MΩ)	>10	>10	>10	>10	>10	>10
Between poles and earth	(MΩ)	>10	>10	>10	>10	>10	>10
Between input and output	(MΩ)	>10	>10	>10	>10	>10	>10



Power circuit for EF contactors

		EF40	EF50	EF65	EF80	EF95	EF105
Three pole version							
Rated thermal current I _{th} at θ ≤ 55°C	(A)	-	90	110	110	140	140
Rated operational current I _e AC-3	(A)	-	50	65	80	95	105
Rated operational voltage U _e	(V)	690V acc. IEC 60947-4-1 / 600V acc. UL-CSA					
Four pole version							
Rated thermal current I _{th} at θ ≤ 55°C	(A)	90	-	110	110	140	-
Rated operational voltage U _e	(V)	690	-	690V acc. IEC 60947-4-1 / 600V acc. UL-CSA			
Three and four pole version							
Rated insulation voltage U _i	(V)	1000V acc. IEC 60947-4-1 / 600V acc. UL-CSA					
Maximum continuous current AC-1	(A)	90	90	110	110	140	140
Frequency limits	(Hz)	25..400	25..400	25..400	25..400	25..400	25..400
Making capacity (RMS) (IEC- 60947)	(A)	1000	1000	1000	1000	1280	1280
Breaking capacity (RMS) (acc. IEC-60947)							
U _e = 400V	(A)	920	920	920	920	1050	1050
U _e = 500V	(A)	920	920	920	920	1050	1050
U _e = 690V	(A)	780	780	780	780	950	950
Short-time current from cold state							
1s	(A)	1580	1580	2530	2530	3300	3300
5s	(A)	565	565	1130	1130	1485	1485
10s	(A)	500	500	800	800	1050	1050
30s	(A)	290	290	460	460	600	600
1min	(A)	205	205	325	325	430	430
3min	(A)	120	120	185	185	250	250
Recovery time	(min)	10	10	10	10	10	10
Protection against short-circuit with fuses without thermal overload relay (TOR)							
Coordination type 1							
gL-gG	(A)	200	200	200	200	250	250
Coordination type 2							
gL-gG	(A)	100	100	125	125	160	200
Without welding							
gL-gG	(A)	80	80	100	100	140	160
Average impedance per pole	(mΩ)	0.85	0.85	0.86	0.86	0.76	0.76
Power dissipation per pole							
AC-1	(W)	6.89	6.86	10.40	10.40	14.89	14.89
AC-3	(W)	1.36	2.12	3.63	5.50	6.86	8.37
Insulation resistance							
Between adjacent poles	(MΩ)	>10	>10	>10	>10	>10	>10
Between poles and earth	(MΩ)	>10	>10	>10	>10	>10	>10
Between input and output	(MΩ)	>10	>10	>10	>10	>10	>10

Control circuit - EC contactors

		EC09 up to EC18 and ECAC	EC25 up to EC40
Rated insulation voltage Ui	(V)	1000	1000
Impulse voltage Uimp	(V)	6000	6000
Mechanical endurance			
Bifrequency coils (at 50Hz)	10° ops.	10	10
Maximum rate			
AC-1 at rated power	ops./h	1200	1200
AC-2 at rated power	ops./h	1200	1000
AC-3 at rated power	ops./h	1200	1000
AC-4 at rated power	ops./h	360	240
No load	ops./h	7200	7200

Control circuit - Alternating current for EC contactors

		EC09 up to EC18 and ECAC	EC25 up to EC40	EC09E up to EC18E	EC25E up to EC40E
Standard voltages Us 50Hz	(V)	12 - 600	12 - 600	24 - 250	24 - 250
Standard voltages Us 60Hz	(V)	12 - 600	12 - 600	24 - 250	24 - 250
Voltage operating limits 50-60Hz coils					
Operating 50Hz xUs		0.8 - 1.1	0.8 - 1.1	0.8 - 1.1	0.8 - 1.1
Operating 60Hz xUs		0.85 - 1.1	0.85 - 1.1	0.8 - 1.1	0.8 - 1.1
Pick-up 50Hz xUs		0.5...0.8	0.6...0.8	0.6...0.8	0.6...0.8
Pick-up 60Hz xUs		0.55...0.85	0.65...0.85	0.6...0.8	0.6...0.8
Drop-out 50Hz xUs		0.35...0.55	0.30...0.55	0.35...0.55	0.35...0.55
Drop-out 60Hz xUs		0.35...0.55	0.30...0.55	0.35...0.55	0.35...0.55
Coil consumption at Us (cold state)					
Magnetic circuit closed (50Hz/60Hz)	(VA)	9 / 6	11.3 / 8.5		
Magnetic circuit opened (50Hz/60Hz)	(VA)	70.1 / 68.2	144 / 138		
Magnetic circuit closed (50Hz&60Hz)	(VA)min-(VA)max			0.7 - 2.2	1.2 - 2.4
Magnetic circuit opened (50Hz&60Hz)	(VA)min-(VA)max			48.6 - 47.2	67 - 64.8
Power factor (50Hz)					
Magnetic circuit closed cos φ		0.24	0.20		
Magnetic circuit opened cos φ		0.85	0.70		
Opening and closing times					
Values between +10% Us and -20% Us					
Making time on energisation (NO)	(ms)	10 - 25	10 - 25		
Breaking time on de-energisation (NO)	(ms)	5 - 15	5 - 15		
Values at Us					
Making time on energisation (NO)	(ms)	10 - 25	10 - 25	25 - 45	40 - 60
Breaking time on de-energisation (NO)	(ms)	5 - 15	5 - 15	50 - 65	60 - 75

Direct current for EC contactors

		Coils with wide voltage range		Coils with low consumption		EC09E up to EC18E	EC25E up to EC40E
		EC09 up to EC18 and ECAC	EC25 up to EC40	EC09 up to EC18	EC25 up to EC40		
Standard voltages Us DC	(V)	12 - 440	12 - 440	12 - 400	12 - 400	24 - 250	24 - 250
Operating Limits							
Operating xUs	(V DC)	0.70 - 1.25	0.70 - 1.25	0.80 - 1.1	0.80 - 1.1	0.80 - 1.1	0.80 - 1.1
Pick-up xUs	(V DC)	0.45 - 0.65	0.45 - 0.65	0.48 - 0.68	0.48 - 0.68	0.6 - 0.8	0.6 - 0.8
Drop-out xUs	(V DC)	0.12 - 0.30	0.12 - 0.30	0.12 - 0.30	0.12 - 0.30	0.35 - 0.55	0.35 - 0.55
Coil consumption at Us (cold state)							
Magnetic circuit open and Closed	(W)	7.5	9	3.6	5.3		
Magnetic circuit Closed	(W)min-(W)max					0.6 - 1	0.9 - 1.2
Magnetic circuit Opened	(W)min-(W)max					3.6	5.3
Opening and closing times							
Values between +10% Us and -20% Us							
Making time on energisation (NO)	(ms)	33 - 78	35 - 154	47 - 173	48 - 96		
Breaking time on de-energisation (NO)	(ms)	14 - 18	15 - 26	12 - 15	8 - 26		
Values at Us							
Making time on energisation (NO)	(ms)	33 - 78	35 - 66	44 - 83	33 - 75	25-45	40-60
Breaking time on de-energisation (NO)	(ms)	14 - 18	15 - 24	13 - 20	12 - 24	50-65	60-75



Control circuit - EF contactors

		EF50A up to EF80A	EF95A up to EF105A
Rated insulation voltage Ui	(V)	1000	1000
Impulse voltage Uimp	(V)	6000	6000
Mechanical endurance			
Bifrequency coils (at 50Hz)	10 ⁶ ops.	5	5
Maximum rate			
AC-1 at rated power	ops./h	1200	1200
AC-2 at rated power	ops./h	1000	750
AC-3 at rated power	ops./h	1200	600
AC-4 at rated power	ops./h	200	200
No load	ops./h	3600	3600

Control circuit - Alternating current for EF contactors

		EF50A up to EF80A	EF95A up to EF105A
Standard voltages Us 50-60Hz	(V)	12 - 600	12 - 600
Voltage operating limits 50-60Hz coils			
Operating 50Hz xUs		0.8 - 1.1	0.8 - 1.1
Operating 60Hz xUs		0.85 - 1.1	0.85 - 1.1
Pick-up 50Hz xUs (at an ambient temperature of 25°C)		0.5...0.8	0.5...0.8
Pick-up 60Hz xUs (at an ambient temperature of 25°C)		0.6...0.8	0.6...0.8
Drop-out 50Hz xUs (at an ambient temperature of 25°C)		0.30...0.55	0.30...0.55
Drop-out 60Hz xUs (at an ambient temperature of 25°C)		0.30...0.55	0.30...0.55
Coil consumption at Us (cold state)			
Magnetic circuit closed (50Hz/60Hz)	(VA)	25 / 16	25 / 16
Magnetic circuit opened (50Hz/60Hz)	(VA)	245 / 204	245 / 204
Thermal power dissipation (50Hz/60Hz)	(VA)	5.2 / 4.3	5.2 / 4.3
Power factor (50Hz)			
Magnetic circuit closed cos φ		0.26	0.26
Magnetic circuit opened cos φ		0.54	0.54
Opening and closing times			
Values between +10% Us and -20% Us			
Making time on energisation (NO)	(ms)	9...35	9...35
Breaking time on de-energisation (NO)	(ms)	9...15	9...15
Values at Us			
Making time on energisation (NO)	(ms)	15...35	15...35
Breaking time on de-energisation (NO)	(ms)	9...15	9...15

Alternating current / Direct current for EF contactors

		Coils with wide voltage range	
		EF50E up to EF80E	EF95E up to EF105E
Rated insulation voltage Ui	(V)	1000	10000
Standard voltages Us DC	(V)	24 - 500	24 - 500
Operating Limits			
Operating xUs	(V DC)	0.85 - 1.1	0.85 - 1.1
Pick-up xUs	(V DC)	0.75	0.75
Drop-out xUs	(V DC)	0.5	0.5
Coil consumption at Us (cold state)			
Magnetic circuit closed (50Hz&60Hz)	(VA)min-(VA)max	2.9 - 5.8	2.9 - 5.8
Magnetic circuit opened (50Hz&60Hz)	(VA)min-(VA)max	136 - 206	136 - 206
Magnetic circuit closed (DC)	(VA)min-(VA)max	2.7 - 3.8	2.7 - 3.8
Magnetic circuit opened (DC)	(VA)min-(VA)max	128 - 214	128 - 214
Opening and closing times			
Values at Us			
Making time on energisation (NO)	(ms)	20 - 45	20 - 45
Breaking time on de-energisation (NO)	(ms)	20 - 55	20 - 55

Built-in auxiliary contacts

		EC09 up to EC25 and ECAC
Rated insulation voltage U_i according to IEC 60947	(V)	1000
Rated thermal current I_{th} at $\theta \leq 55^\circ\text{C}$	(A)	10
Making capacity (RMS) acc. to IEC 60947		
AC-15 $U_e \leq 400\text{V}$, 50-60Hz	(A)	105
DC-13 $U_e \leq 220\text{V DC}$	(A)	105
Breaking capacity (RMS) acc. to IEC 60947		
AC-15 $U_e \leq 400\text{V}$, 50-60Hz	(A)	105
DC-13 $U_e \leq 220\text{V DC}$	(A)	2
AC-15 rated voltage and current U_e - I_e according to IEC	(V-A)	110/120-10
		220/230-10
		380/400-6
		415/450-5
		500-4
		690/660-2
according to UL, CSA		A600
DC-13 rated voltage and current U_e - I_e according to IEC	(V-A)	24-6
		48-4
		110-2
		220-0.7
		440-0.35
according to UL, CSA		Q600
Electrical endurance	10^6 ops.	0.2
Minimum operational power (operational safety)		17 V - 5mA
Short-circuit protection max. fuse class gl-gG without welding	(A)	10
Insulation resistance	Between contacts (M Ω)	>10
	Between contacts and earth (M Ω)	
Guaranteed no overlap between NO and NC contacts		
Space		1.3mm
Impedance of the contacts	(M Ω)	2.7

Auxiliary contact blocks

		ECFA/ECLA/BCLL
Rated insulation voltage U_i according to IEC 60947	(V)	1000
Rated thermal current I_{th} at $\theta \leq 55^\circ\text{C}$	(A)	10
Making capacity (Ieff) according to IEC 60947		
AC-15 $U_e \leq 400\text{V}$, 50-60Hz	(A)	60
DC-13 $U_e \leq 220\text{V DC}$	(A)	60
Breaking capacity (Ieff) according to IEC 60947		
AC-15 $U_e \leq 400\text{V}$, 50-60Hz	(A)	60
DC-13 $U_e \leq 220\text{V DC}$	(A)	0.95
AC-15 rated voltage and current U_e - I_e according to IEC	(V-A)	110/120-6
		220/230- 6
		380/400-4
		415/440-3.5
		500-2.5
		660/660-1.5
according to UL, CSA		A600
DC-13 rated voltage and current U_e - I_e according to IEC	(V-A)	24-4
		48-2
		110-0.7
		220-0.3
		440-0.15
according to UL, CSA		Q600
Electrical endurance	10^6 ops.	0.2
Mechanical endurance	10^6 ops.	10
Minimum operational current (operational safety)		17-5 V-mA
Short-circuit protection max. fuse class gl-gG without welding	(A)	10
Insulation resistance	Between contacts (M Ω)	>10
	Between contacts and earth (M Ω)	
Guaranteed no overlap between NO and NC contacts		
Space		1.6mm for ECFA / 2.2mm for ECLA/ 1.3mm for BCLL
Impedance of the contacts	(milli)	2.7

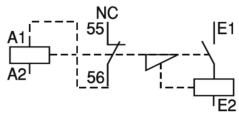
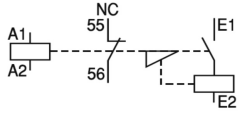

Mechanical latch blocks

Rated insulation voltage U_i	(V)	1000
Standard voltages U_s : 50 to 60Hz and DC	(V)	24-660 & 24-440
Operating limits		85% to 110%
Consumption for unlatching (auto cut-out)	AC/DC	
24 to 72V		30W / 25VA
110 to 440V		15W / 12VA
Electrical unlatching control		
Minimum impulse	(ms)	25
Maintained		Auto cut by internal contact
Manual unlatching control		By manual push-button
Electrical making control		
Minimum pulse	(ms)	40 (auto cut)
Manual making control		By manual push-button
Auxiliary contact NC		
AC-15 utilisation	(V-A)	110/120-6
according to IEC		220/230-6
		380/400-4
		415/450-3.5
		500-2.5
		690/660-1.5
according to UL/CSA		B600
DC-13 utilisation	(V-A)	24-4
according to IEC		48-2
		110-0.7
		220-0.3
		440-0.15
according to UL/CSA		Q600
Mechanical endurance	10^6 ops.	0.2
Wiring diagrams		
Alternating current		
		
Alternating current / Direct current		
		

Terminal capacity

Terminal capacity		Screw plate ECML*A, ECML*D
Flexible wire	(mm ²)	2x0.5...2.5
AWG wire		2x20...14
Standard gauge		A3
Tightening torque	(Nm/Lb-in)	1.1 / 10

Terminal numbering

3P and 4P contactors

EC09A311..EC25A311	EC32A300..EF105A300	EC12A400..EF95A400	EC12AB00..EC25AB00	EC32AB00..EF80AB00
EC09D311..EC25D311	EC32D300..EF105E300	EC12D400..EF95E400	EC12DB00..EC25DB00	EC32DB00..EF80EB00
EC09E311..EC25E311	EC32E300..EF105E300	EC12E400..EF95E400	EC12EB00..EC25EB00	EC32EB00..EF80EB00

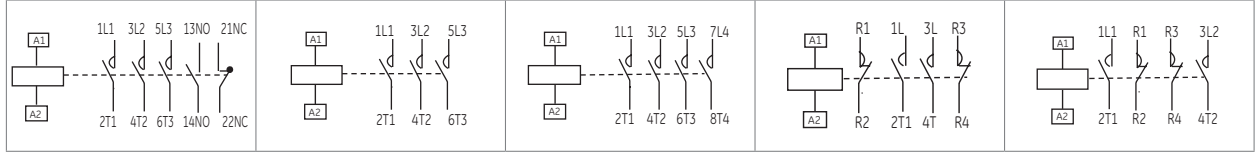

Auxiliary contact blocks - Front mounting

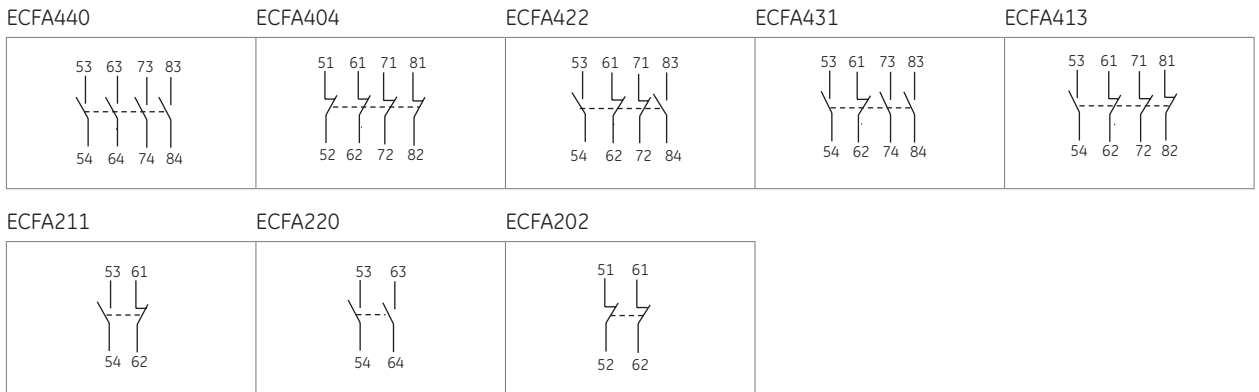

Auxiliary contact blocks - Lateral mounting

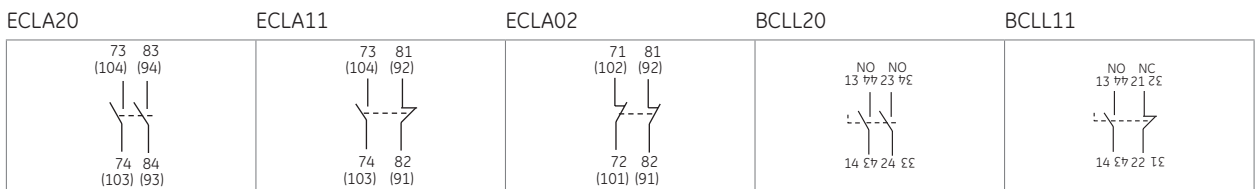

Mechanical and mechanical/electrical interlock

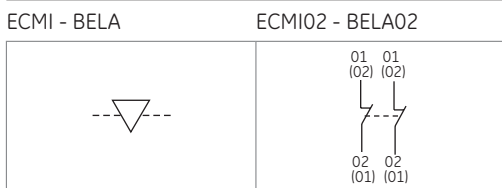

Terminal numbering (continued)

Pneumatic timer blocks

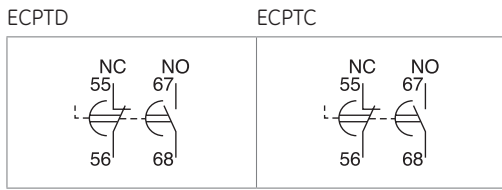

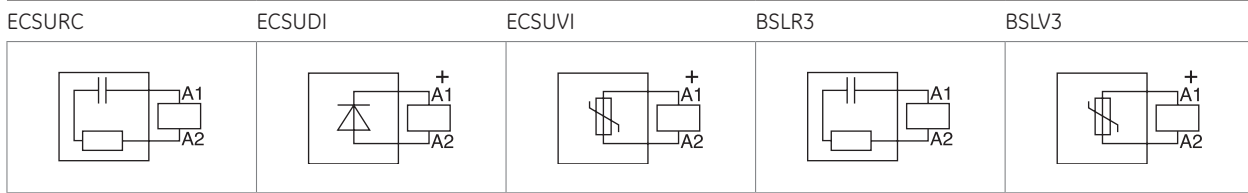

Voltage suppressor blocks



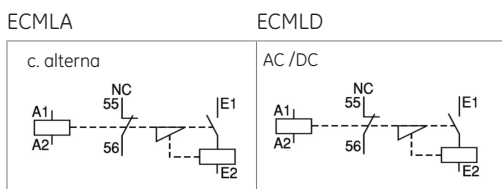



Mechanical latch block





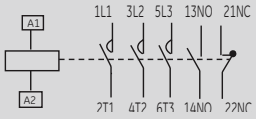

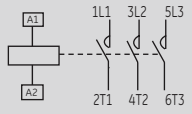





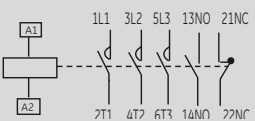

Terminal numbering according to EN 50012

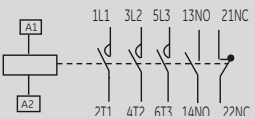
Auxiliary contacts	Description			Possible basic auxiliary contactors + Auxiliary contacts blocks to be added
--------------------	-------------	---	---	---

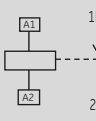

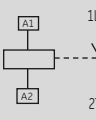

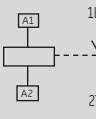
Terminal numbering according to EN 50012

	11E	1	1	EC09A311..EC25A311 EC09D311..EC25D311 EC09E311..EC25E311	
	-	0	0	EC32A300..EF105A300 EC32D300..EF105E300 EC32E300..EF105E300	

FRONT mounted auxiliary contact blocks with 2 contacts each

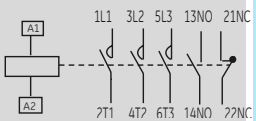

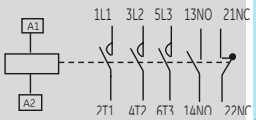
	13	1	3	EC09A311..EC25A311 EC09D311..EC25D311 EC09E311..EC25E311 +ECFA202	
	31	3	1	EC09A311..EC25A311 EC09D311..EC25D311 EC09E311..EC25E311 +ECFA220	
	22	2	2	EC09A311..EC25A311 EC09D311..EC25D311 EC09E311..EC25E311 +ECFA211	
	02	0	2	EC32A300..EF105A300 EC32D300..EF105E300 EC32E300..EF105E300 +ECFA202	
	20	2	0	EC32A300..EF105A300 EC32D300..EF105E300 EC32E300..EF105E300 +ECFA220	
	11	1	1	EC32A300..EF105A300 EC32D300..EF105E300 EC32E300..EF105E300 +ECFA211	

LATERAL mounted auxiliary contact blocks with 2 contacts each - RIGHT side mounted









	13	1	3	EC09A311..EC25A311 EC09D311..EC25D311 EC09E311..EC25E311 +ECLA220	
	22	2	2	EC09A311..EC25A311 EC09D311..EC25D311 EC09E311..EC25E311 +ECLA211	

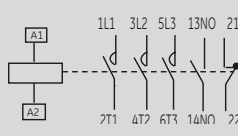

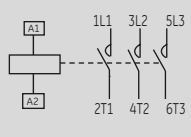

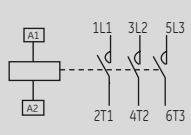

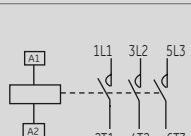





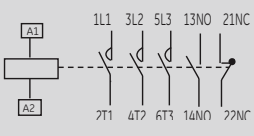

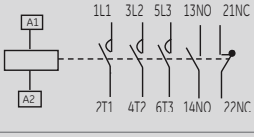
Terminal numbering according to EN 50012 (continued 1)

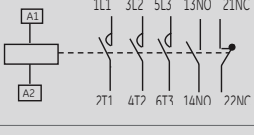
Auxiliary contacts	Description			Possible basic auxiliary contactors + Auxiliary contacts blocks to be added
--------------------	-------------	---	---	---

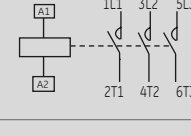

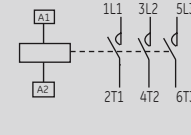
LATERAL mounted auxiliary contact blocks with 2 contacts each - RIGHT side mounted (continued)

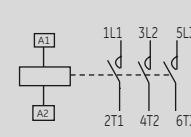
	31	3	1	EC09A311..EC25A311 EC09D311..EC25D311 EC09E311..EC25E311 +ECLA220	
	02	0	2	EC32A300..EC40A300 EC32D300..EC40D300 EC32E300..EC40E300 +ECLA202	
	11	1	1	EC32A300..EC40A300 EC32D300..EC40D300 EC32E300..EC40E300 +ECLA211 EF50A300....EF105A300 EF50E300....EF105E300 +BCLL11	
	20	2	0	EC32A300..EC40A300 EC32D300..EC40D300 EC32E300..EC40E300 +ECLA220 EF50A300....EF105A300 EF50E300....EF105E300 +BCLL20	















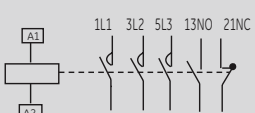



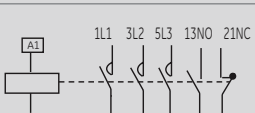

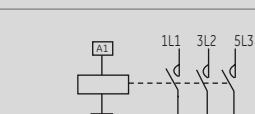
LATERAL mounted auxiliary contact blocks with 2 contacts each - LEFT side mounted

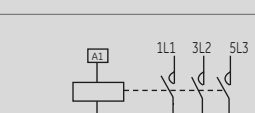
	13	1	3	EC09A311..EC25A311 EC09D311..EC25D311 EC09E311..EC25E311 +ECLA202	
	22	2	2	EC09A311..EC25A311 EC09D311..EC25D311 EC09E311..EC25E311 +ECLA211	
	31	3	1	EC09A311..EC25A311 EC09D311..EC25D311 EC09E311..EC25E311 +ECLA220	
	02	0	2	EC32A300..EC40A300 EC32D300..EC40D300 EC32E300..EC40E300 +ECLA202	
	11	1	1	EC32A300..EC40A300 EC32D300..EC40D300 EC32E300..EC40E300 +ECLA211 EF50A300....EF105A300 EF50E300....EF105E300 +BCLL11	
	20	2	0	EC32A300..EC40A300 EC32D300..EC40D300 EC32E300..EC40E300 +ECLA220 EF50A300....EF105A300 EF50E300....EF105E300 +BCLL20	

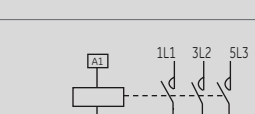
Terminal numbering according to EN 50012 (continued 2)

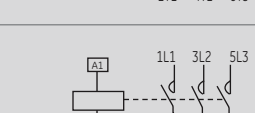
Auxiliary contacts	Description			Possible basic auxiliary contactors + Auxiliary contacts blocks to be added
--------------------	-------------	---	---	---

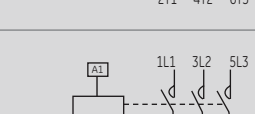
FRONT mounted auxiliary contact blocks with 4 contacts each

	51	5	1	EC09A311..EC25A311 EC09D311..EC25D311 EC09E311..EC25E311 +ECFA440	
	15	1	5	EC09A311..EC25A311 EC09D311..EC25D311 EC09E311..EC25E311 +ECFA404	
	33	3	3	EC09A311..EC25A311 EC09D311..EC25D311 EC09E311..EC25E311 +ECFA422	
	42	4	2	EC09A311..EC25A311 EC09D311..EC25D311 EC09E311..EC25E311 +ECFA431	
	24	2	4	EC09A311..EC25A311 EC09D311..EC25D311 EC09E311..EC25E311 +ECFA413	
	40	4	0	EC09A311..EC25A311 EC09D311..EC25D311 EC09E311..EC25E311 +ECFA440	
	04	0	4	EC09A311..EC25A311 EC09D311..EC25D311 EC09E311..EC25E311 +ECFA404	
	22	2	2	EC32A300..EF105A300 EC32D300..EF105E300 EC32E300..EF105E300 +ECFA422	
	31	3	1	EC32A300..EF105A300 EC32D300..EF105E300 EC32E300..EF105E300 +ECFA431	
	13	1	3	EC32A300..EF105A300 EC32D300..EF105E300 EC32E300..EF105E300 +ECFA413	

Global contactors

Intro

A

B

C

D

E

F

G

H

I

X



Technical data

General

		MC1...	MC2...
Rated thermal current I _{th} θ ≤ 60 °C ⁽¹⁾	(A)	20	20
Rated operational current I _e ⁽²⁾ (3 × 440V, 50/60Hz, AC-3)	(A)	9	12
Maximum number of poles		4	4
Rated insulation voltage U _i	(V)	750	750
Rated operational voltage U _e	(V)	690	690

- (1) Insulated terminal type B 2.8×0.8 with wire 1mm²:
I_e = 8A, design DIN 46 247
(2) Max. operational current AC3, 3 -phase ≤ 440V,
according to IEC 947-4-1

Conformity to standards

IEC/EN 60947-1	CSA C22.2/14	SEV 10254
IEC/EN 60947-4-1	CENELEC HD 419	JIS C8325
IEC/EN 60947-5-1	VDE 0660	JEM 1038
EN 50003	NFC 63110	NEMA ICS-1
EN 50005	BS 4794	UL 508
EN 50012		

Approvals

cULus	NEMKO	SEMKO
SETI	DEMKO	RINA
IMQ		
Lloyd's Register	Bureau Veritas	CE

Ambient conditions

Storage temperature		-55°C to +80°C
Operation temperature		-40°C to +55°C
Altitude	up to 3000m	Nominal values
	from 3000 up to 4000m	90%I _e 80%U _e
	from 4000 up to 5000m	80%I _e 75%U _e

Climatic resistance

Continuous tests 40 / 125 / 56		
Cold (72h)		
Temperature		-40°C
Dry heat (96h)		
Temperature		+125°C
Relative humidity		< 50%
Humid heat (56h)		
Temperature		+40°C
Relative humidity		95%
Cyclic tests		
First half-cycle (12h)		
Low temperature		+25°C
Relative humidity		93%
Second half-cycle (12h)		
Low temperature		+55°C
Relative humidity		95%
Number of consecutive cycles		6

Coil Terminal capacity and tightening torque

Tightening torque		0.8Nm - 7Lb/in
Solid Wire	(mm ²)	0.75 to 2x2
Flexible wire without terminal	(mm ²)	0.75 to 2.5x2
Flexible wire without terminal with cap	(mm ²)	0.75 to 2.5x21

Shock resistance (IEC 68-2-27)

Continuously closed (at 0.8Us)	
Admissible acceleration	25g
Impulse duration	11 ms
Continuously opened (no voltage)	
Admissible acceleration	20g
Impulse duration	11 ms

Vibration resistance (IEC 68-2-6)

Continuously closed (at 0.8Us)	
Admissible acceleration	15g
Sweep between	10 - 200Hz
Continuously opened (no voltage)	
Admissible acceleration	5g (AC) - 35g (DC)
Sweep between	10 - 200Hz

Mounting positions

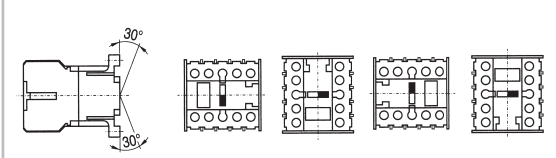

With the same pick-up and drop-out voltage
With the same rated power

-7% of connection voltage
+4% of disconnection voltage
With the same rated power

7% of connection voltage
+4% of disconnection voltage
With the same rated power

Terminal capacity

Terminal with M3.5 screw (with pozidrive head and safety flange)	Tightening torque	
		0.8Nm - 7 Lb/in
Solid wire	mm ²	0.75 to 2x2 w.
Flexible wire without terminal	mm ²	0.75 to 2.5x2 w.
Flexible wire without terminal with cap	mm ²	0.75 to 2.5x1 w.
Ring terminal	mm ²	0.75 to 1x2 w.
		0.8Nm - 7 Lb/in

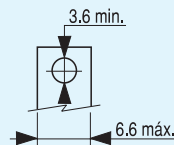

Faston terminal 2.8 - 2 insulated terminals	mm ²	1x2w.
Terminal for printed circuit (Ø of PCB hole)		1.8mm
Ring terminal cap		7.8mm
Fork terminal cap		6.5 mm

Control circuit

		MC_A...	MC_C...	MC_L...	MC_K...	MC_C...W
Rated insulation voltage (Ui)	(V)	750	750	750	750	750
Standard voltages (Us)						
50Hz(V)		24 ... 690	-	-	-	-
60Hz(V)		6 ... 600	-	-	-	-
DC	(V)	-	6 ... 440	24	24	12 ... 440
Operating voltages limits						
Operating ^[1]	xUs	0.8 ... 1.1	0.8 ... 1.1	0.8 ... 1.25	0.7 ... 1.25	0.7 ... 1.3
Drop-out	xUs	0.35 ... 0.55	0.15 ... 0.4	0.15 ... 0.3	0.15 ... 0.35	0.15 ... 0.3
Operating voltages limits with coil 50/60Hz						
Operating	xUs	0.8 ... 1.1	-	-	-	-
Drop-out	xUs	0.35 ... 0.55	-	-	-	-
Consumption						
50 or 60Hz - monofrequency coil						
Pick-up	(VA)	26	-	-	-	-
Seal	(VA)	4	-	-	-	-
50/60Hz - bifrequency coil						
Pick-up	(VA)	32	-	-	-	-
Seal	(VA)	6	-	-	-	-
DC	(W)	-	3	1.2	2	4
Power factor						
Magnetic circuit open	(cos φ)	0.8	-	-	-	-
Magnetic circuit closed	(cos φ)	0.35	-	-	-	-
Power dissipation	(W)	1.4	3	1.2	2	4
Opening and closing times						
Values between ±%Us	%	+10 ... -20	+10 ... -20	+25 ... -30	+25 ... -30	+30 ... -30
Time on energisation NO	(ms)	6 ... 13	22 ... 36	30 ... 70	20 ... 50	17 ... 28
Time on de-energisation NC	(ms)	8 ... 16	9 ... 12	9 ... 16	9 ... 16	9 ... 12
Time on energisation NC	(ms)	5 ... 11	18 ... 27	20 ... 45	18 ... 35	12 ... 25
Time on de-energisation NO	(ms)	6 ... 13	5 ... 7	5 ... 9	5 ... 9	5 ... 7
Values at Us						
Time on excitation NO	(ms)	7 ... 12	24 ... 27	25 ... 45	25 ... 40	11 ... 23
Time on desexcitation NC	(ms)	8 ... 16	9 ... 11	9 ... 16	9 ... 16	9 ... 11
Time on excitation NC	(ms)	6 ... 10	20 ... 26	25 ... 35	20 ... 30	15 ... 21
Time on desexcitation NO	(ms)	6 ... 13	5 ... 8	5 ... 9	5 ... 8	5 ... 8
Maximum time without voltage	(ms)	3	3	3	3	3
Mechanical endurance						
Monofrequency coil	10 ⁶ ops.	>15	-	-	-	-
Bifrequency coil	10 ⁶ ops.	>10	-	-	-	-
DC	10 ⁶ ops.	-	10	10	10	10
Maximum rate						
No load	Monofrequency coil	ops./h	9000	-	-	-
	Bifrequency coil	ops./h	3600	-	-	-
	DC	ops./h	-	9000	9000	9000
AC1 and AC3 (at rated power)		ops./h	1200	1200	1200	1200
AC4 (at rated power)		ops./h	300	300	300	300



Main circuit (poles)

		MC1...	MC2...
Rated insulation voltage (Ui) (acc. IEC 947-4)	(V)	750	750
Rated thermal current (Ith) $\theta \leq 60^\circ$ [1]	(A)	20	20
Frequency limits	(Hz)	0...400	0...400
Making capacity (r.m.s.) $U_e \leq 690V$ 50/60Hz	(A)	160	160
Breaking capacity (r.m.s.) $U_e \leq 440V$	(A)	106	106
$U_e = 500V$	(A)	90	90
$U_e = 690V$	(A)	80	90
Short-time current			
0.3 sec.	(A)	470	470
1 sec.	(A)	250	250
5 sec.	(A)	125	125
10 sec.	(A)	95	95
30 sec.	(A)	70	70
1 min.	(A)	50	50
3 min.	(A)	40	40
Recovery time	min.	10	10
Protec. against short-circuits (IEC 947-4), w/o TOR			
Coordination type "1" gL/gG	(A)	32	32
Coordination type "2" gL/gG	(A)	20	20
w/o welding contacts gL/gG	(A)	16	16
Circuit breaker rating (curve G CEE 19.1)		20	20
Impedance per pole	(m Ω)	1.5	1.5
Power dissipation per pole			
AC1	(W)	0.6	0.6
AC3	(W)	0.128	0.228
Insulation resistance			
Between adjacent poles	(M Ω)	> 10	> 10
Between pole and earth	(M Ω)	> 10	> 10
Between input and output	(M Ω)	> 10	> 10
Guaranteed no overlap between NO and NC contacts			
Space	(mm)	1	1
Time	(ms)	> 2	> 2

[1] Insulated terminal type B 2.8x0.8 with wire 1mm² Ie = 8A acc. to DIN 46247

Electrical endurance

Category AC1

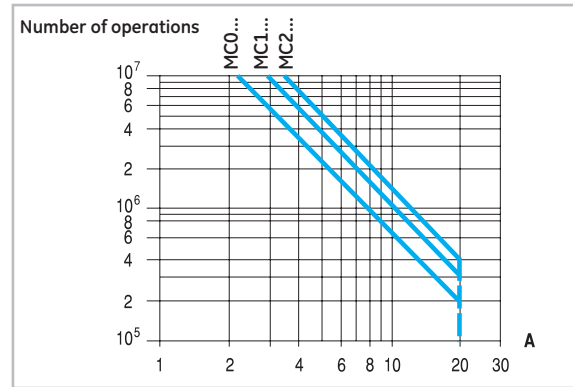

Category AC3

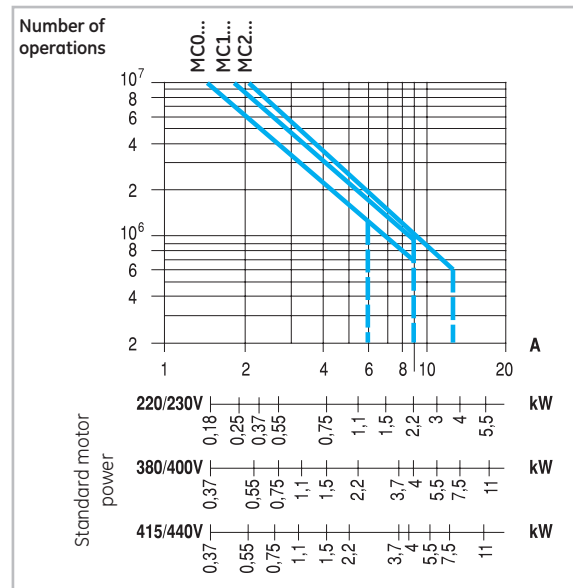

Category AC4

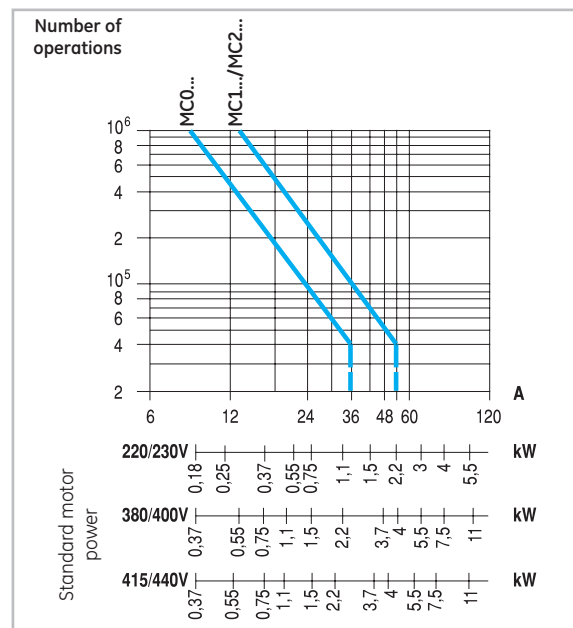

Internal auxiliary contacts

		MC1 / MC2
Rated insulation voltage (Ui) IEC 60947-5	(V)	750
Rated thermal current (Ith) $\theta \leq 60^{\circ}\text{C}^{21}$	(A)	16
Making capacity according with IEC 60947-5-1		
Ue ≤ 690 50-60Hz	(A)	160
Ue ≤ 440 V DC	(A)	160
Breaking capacity (r.m.s.) IEC 60947-5-1		
AC-15		
Ue ≤ 440 V / 50-60Hz	(A)	106
DC-13		
Ue ≤ 110 V DC	(A)	3
Ue = 220 V DC	(A)	1.2
Ue = 48 V DC	(A)	10
Minimum operational power (operational safety.)		5mA, 17V
Short-circuit protection (max.class gI fuse) w/o welding	(A)	10
Insulation resistance		
Between adjacent contacts	(M Ω)	> 10
Between contacts and earth	(M Ω)	> 10
Between input and output	(M Ω)	> 10
Guaranteed no overlap between NO and NC contacts		
Space	(mm)	0,5
Minimal time	(ms)	> 2
Impedance	(m Ω)	2,3
Terminal capacity		Same as main circuit

(1) Insulated terminal type B 2.8x0.8 with wire 1mm² Ie = 8A acc. with DIN 46247

DC characteristics

DC Inductive circuit. DC-13 L/R ≤ 15 ms
Electrical endurance 10^6 ops.

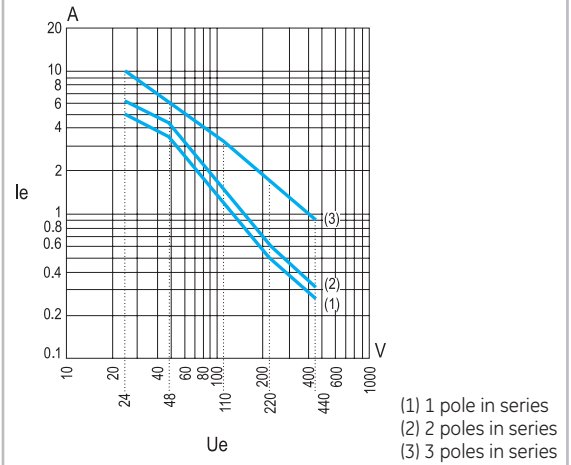

DC Inductive circuit. DC-13 L/R ≤ 1 ms
Electrical endurance 10^5 ops.

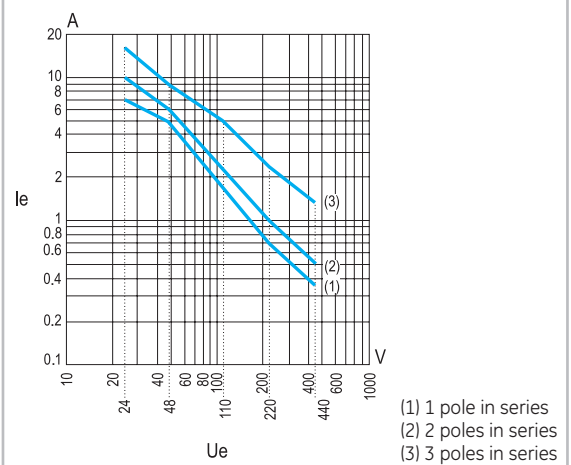

AC characteristics

AC Operation AC-15
Electrical endurance

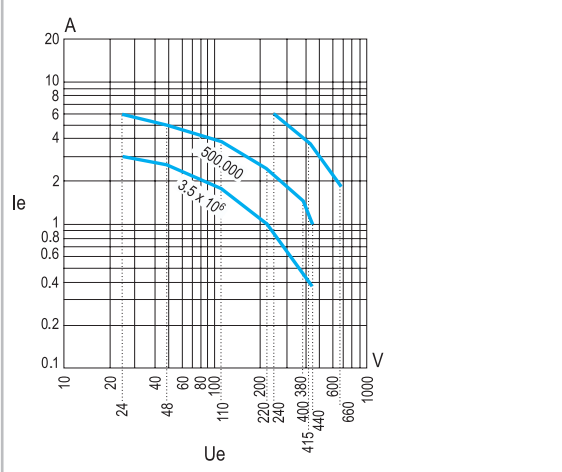

Instantaneous auxiliary contact blocks

		MACN..., MACL...
Rated insulation voltage (Ui) acc. IEC 60947-1	(V)	750
Rated thermal current (Ith) $\theta \leq 60^\circ\text{C}^{(1)}$	(A)	10
Making capacity (r.m.s.) according with IEC/EN 60947-5-1		
AC-15	Ue $\leq 220\text{V}$ 50/60Hz	(A) 73
	Ue = 380V 50/60Hz	(A) 38
	Ue = 690V 50/60Hz	(A) 22
DC-13	Ue $\leq 100\text{V}$ DC	(A) 2.6
	L/R=100ms Ue = 220V DC	(A) 1
	Ue = 440V DC	(A) 0.6
Breaking capacity (r.m.s.) acc. IEC/EN 60947-5-1		
AC-15	Ue $\leq 220\text{V}$ 50/60Hz	(A) 73
	Ue = 380V 50/60Hz	(A) 38
	Ue = 690V 50/60Hz	(A) 22
DC-13	Ue $\leq 100\text{V}$ DC	(A) 2
	LR=100ms Ue = 220V DC	(A) 0.8
	Ue = 440V DC	(A) 0.4
Rated voltage and rated current Ue-le		
AC-15	according to IEC 60947	120V - 6A
		230V - 6A
		400V - 4A
		500V - 1A
		600V - 1A
		A600
DC-13	according to IEC 60947	24V - 4A
		48V - 2A
		110V - 0.7A
		220V - 0.3A
		440V - 0.1A
		Q600
	according to UL, CSA	5 mA, 17V
Minimum operational power (operational safety)		5 mA, 17V
Short-circuit protection	(A)	10
Insulation resistance		
	Between adjacent contacts (M Ω)	> 10
	Between contacts an earth (M Ω)	> 10
	Between input and output (M Ω)	> 10
Guaranteed no overlap between NO and NC contacts		
	Space (mm)	0.5
	Minimal time (ms)	> 2
Impedance	(m Ω)	2.4
Terminal capacity		Same as main circuit

(1) Insulated terminal type B 2.8x0.8 with wire 1mm² le = 8A acc. with DIN 46247

AC characteristics

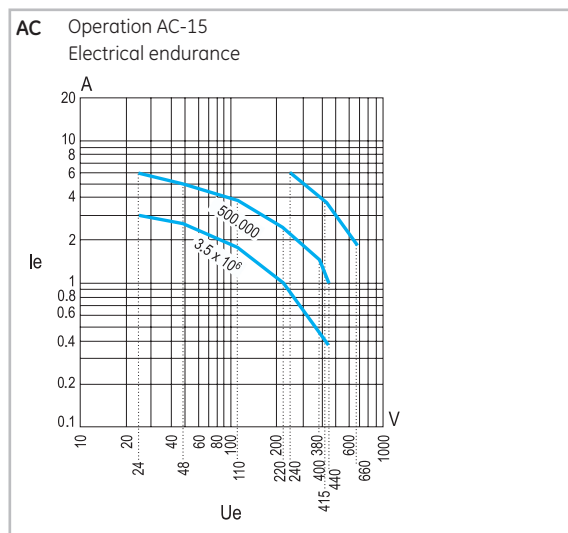

DC characteristics

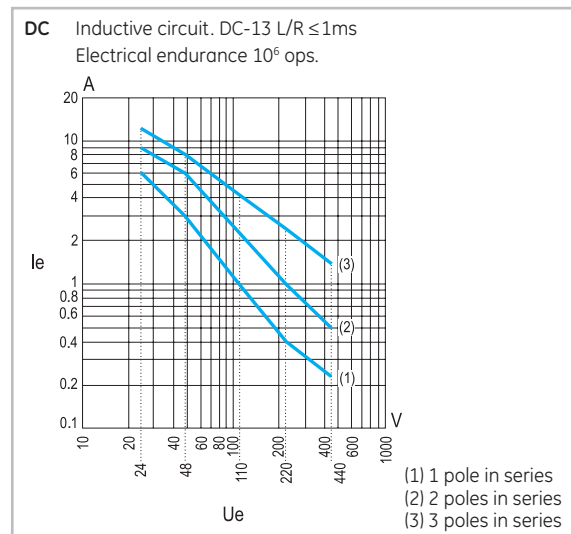
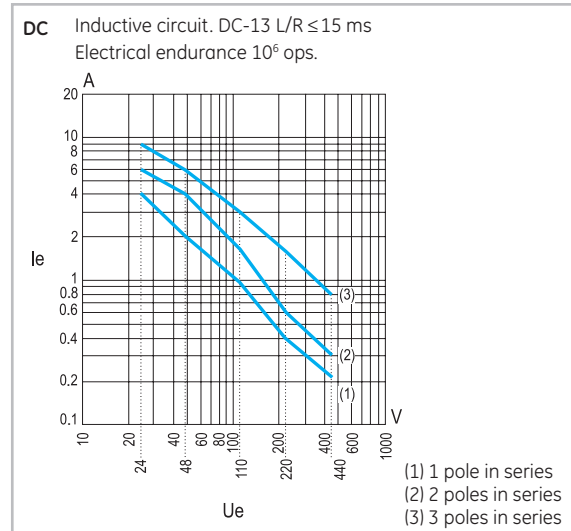
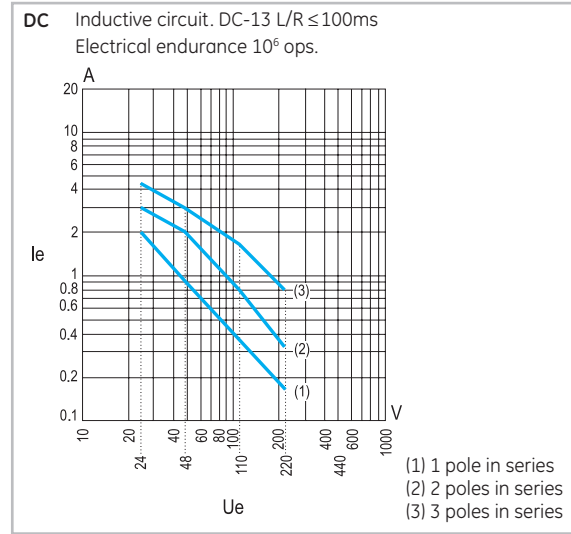

Electronic timer block



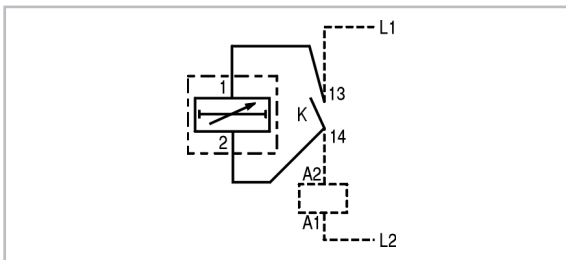









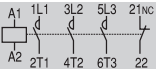

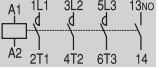

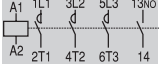

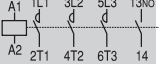

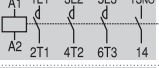

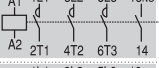

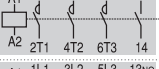

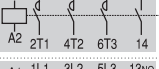

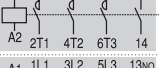
		MREBC...
Rated insulation voltage (Ui)	(V)	750
Rated thermal current (Ith) $\theta \leq 60^\circ\text{C}^{\text{II}}$	(A)	0.55
Supply voltage (AC and DC)	(V)	24 to 250
Operating limits		0.80 to 1.1 Us (0.85 to 1.1 Us to 12V)
Voltage drop	(V)	< 3
Maximum load current at :		
20°C	(A)	0.9
40°C	(A)	0.72
60°C	(A)	0.55
Minimum load for safe operation	(A)	> 10
Maximum current	(A)	10A per 40ms
Leakage current at 220V	(mA)	< 5
Operational current		
AC-15	(A)	0.7
DC-13	(A)	0.9
Timing range (delay ON)	(s)	0.5 to 60 ($\pm 6\text{s}$)
Rearrangement time	(ms)	< 100
Repeatability (accuracy) (%)		± 1
Ambient temperature		
storage	(°C)	-55 to + 80
operation	(°C)	-5 to + 60
Degree of protection		IP20
Mounting positions		Any
Terminals: 2 free cables		1mm ² (AWG 17) 250mm

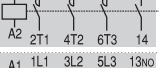

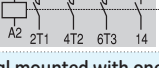
Contact sequence

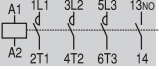
	Main contact (NO)	Main contact (NC)	Auxiliary contact (NO)	Auxiliary contact (NC)
Three-pole minicontactor				
MC...310...				
MC...301...				
Four-pole minicontactor				
MC...400...				
MC...B00...				
MC...A00...				
Auxiliary contact block				
MAC...				
MAR...				

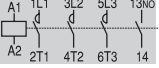
Terminal numbering in accordance with EN 50012

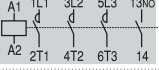
Final structure of the contactor	Auxiliary contactors		Possible basic contactors + Auxiliary contact blocks to be added
	Combination	 	
	Description		
Without auxiliary contact blocks			
 	01E	0 1	MC_A301A...
 	10E	1 0	MC_A310A...
Auxiliary contact blocks front mounted with two or four contacts			
 	11E	1 1	MC_A310A... + MACN211A
 	21E	2 1	MC_A310A... + MACN211A
 	12E	1 2	MC_A310A... + MACN202A
 	31E	3 1	MC_A310A... + MACN431A
 	41E	4 1	MC_A310A... + MACN431A
 	22E	2 2	MC_A310A... + MACN422A
 	32E	3 2	MC_A310A... + MACN422A
 	13E	1 3	MC_A310A... + MACN413A
 	23E	2 3	MC_A310A... + MACN413A
Auxiliary contact blocks lateral mounted with one contact			
 	11E	1 1	MC_A310A... + MACL101A
 	21E	2 1	MC_A310A... + MACL101A + MACL110A
 	12E	1 2	MC_A310A... + MACL101A + MACL101A

Technical data

Intro

A

B

C

D

E

F

G

H

I

X



Wiring diagrams

Basic three-pole contactors. (EN 50012)

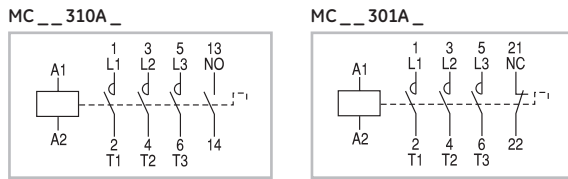

Instantaneous auxiliary contact blocks. (EN 50012)

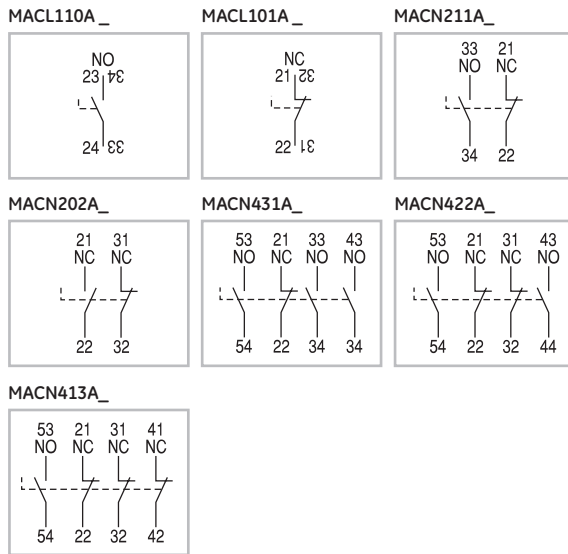

Instantaneous auxiliary contact blocks. (EN 50005)

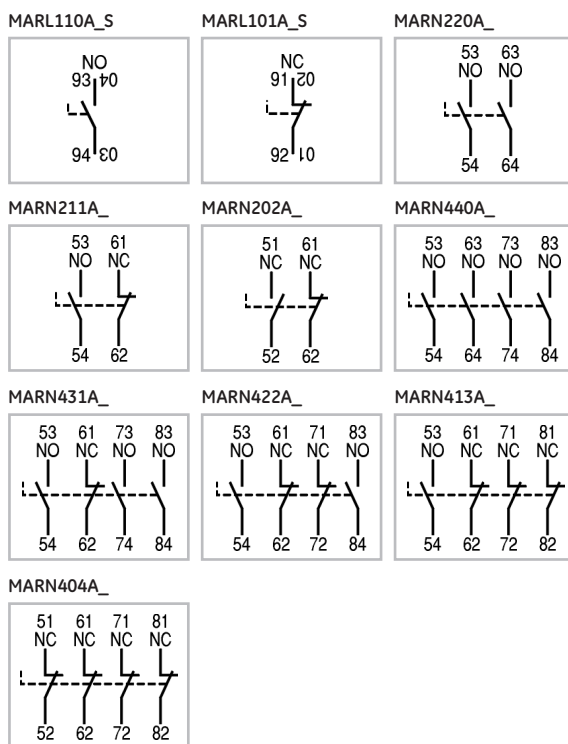

Base four-pole contactors. (EN 50005)

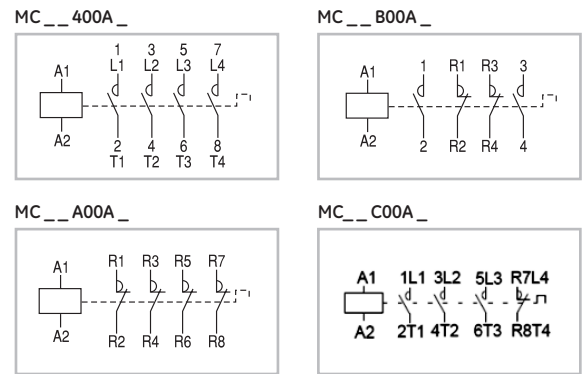

Instantaneous auxiliary contact blocks. (EN 50005)

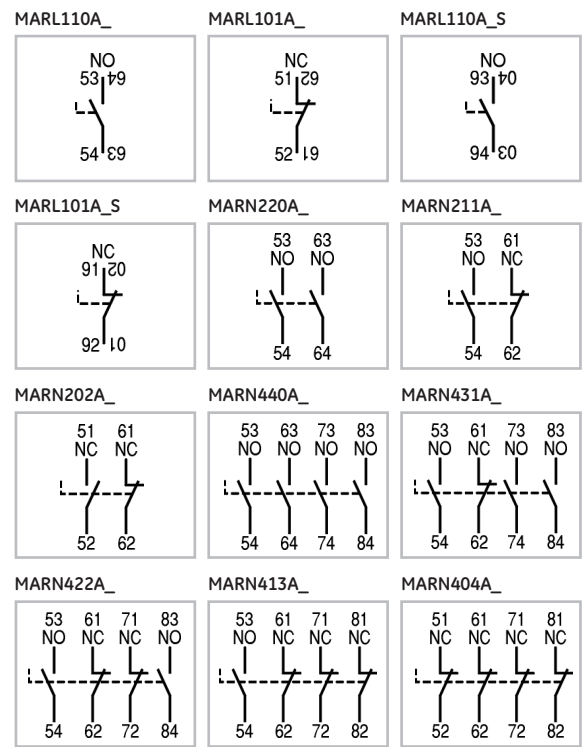

Voltage suppressor block

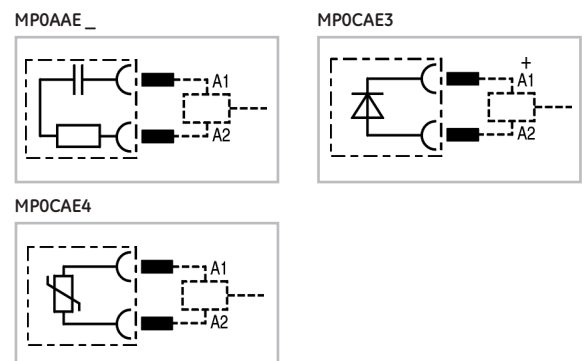

Everything is under control

Conformity to standards

IEC/EN 60947-1	EN 50005	UNE 20109
IEC/EN 60947-4-1	CENELEC HD419	BS 5424 & 775
IEC/EN 60947-5-1	NF C63-110	NEMA ICS 1
UL 508	ASE 1025	VDE 0660/102
CSA 22.2/14		

Approvals/Marking

cULus	RINA	CE
SETI	IMQ (up to Ith:32A)	
Lloyd's Register	Bureau Veritas	

Ambient conditions

Storage temperature	-55°C to +80°C	
Operation temperature	-40°C to +55°C	
Altitude	up to 3000m	Nominal values
	from 3000 up to 4000m	90%le 80%Ue
	from 4000 up to 5000m	80%le 75%Ue

Climatic resistance (IEC 68-2)

Continuous tests 40 / 125 / 56		Cyclic test (6 cycles)	
Cold (72h)		Humid heat	
Temperature	-40°C	First half-cycle (12h)	
Dry heat (96h)		Low temperature	+25°C
Temperature	+125°C	Relative humidity	93%
Relative humidity	< 50%	Second half-cycle (12h)	
Humid heat (56h)		Low temperature	+55°C
Temperature	+40°C	Relative humidity	95%
Relative humidity	95%		

Mounting positions

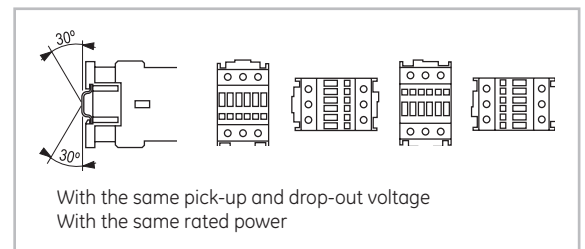

Terminal capacity and tightening torque

		CL00 ... CL02	CL03	CL03*4 & CL04	CL05A3	CL05 ... CL08	CL09 ... CL10
	Solid, stranded and finely stranded without end sleeve (mm²)	2 x 0.5 ... 2.5	2 x 0.5 ... 2.5	-	-	-	-
	Finely stranded with or without end sleeve (mm²)	2 x 1 ... 2.5	2 x 1 ... 2.5	-	-	-	-
	AWG wires	2 x 20 ... 12	2 x 20 ... 8	-	-	-	-
	Tightening torque (Nm)	1.6	2.2	-	-	-	-
	(Lb x in.)	15	20	-	-	-	-
	Solid, stranded and finely stranded without end sleeve (mm²)	-	-	0.75 ... 16	0.75 ... 16	1 ... 35	1.5 ... 50
	Finely stranded with end sleeve (mm²)	-	-	0.75 ... 16	0.75 ... 16	1 ... 35	1.5 ... 50
	Finely stranded w/o end sleeve (mm²)	-	-	1 ... 16	1 ... 16	1 ... 35	1.5 ... 50
	AWG wires	-	-	18 ... 6	18 ... 6	16 ... 2	16 ... 2
	Tightening torque (Nm)	-	-	1.4	1.8	(4-4.5)	(5.6-6.5)
(Lb x in.)	-	-	12	16	35	50	
	Solid (mm²)	-	-	0.75 ... 16	0.75 ... 16	1 ... 16	4 ... 35
	Stranded (mm²)	-	-	0.75 ... 16	0.75 ... 16	1 ... 25	4 ... 35
	Finely stranded w/o end sleeve (mm²)	-	-	0.75 ... 16	0.75 ... 16	1 ... 25	4 ... 35
	Finely stranded with end sleeve (mm²)	-	-	1 ... 16	1 ... 16	1 ... 25	4 ... 35
	AWG wires	-	-	18 ... 6	18 ... 6	16 ... 4	10 ... 1
Tightening torque (Nm)	-	-	1.4	1.8	(4-4.5)	5.6	
(Lb x in.)	-	-	12	16	35	50	
	Solid, stranded and finely stranded without end sleeve (mm²)	-	-	Max. 16	Max. 16	Max. 50 ... 4	Max. 50 ... 35
	Finely stranded w/o end sleeve (mm²)	-	-			Max. 25 ... 16	
	Finely stranded with end sleeve (mm²)	-	-			Max. 25 ... 16	
	AWG wires	-	-	Max. 6	Max. 6	Max. 25 ... 25	Max. 1
	Tightening torque (Nm)	-	-	1.4	1.8	Max 4 ... 4	5.6
(Lb x in.)	-	-	12	16	35	50	
	Ring terminals (Ø i)	3.6	4.2	4.2	4.2	6.2	6.2
	(acc. with IEC/EN 60947-1) (A)	8	10	10	10	12.5	12.5
	Tightening torque (Nm)	1.6	1.4	1.4	1.4	3	3
(Lb x in.)	15	12	12	12	26	26	

Coil Terminal capacity and tightening torque

Tightening torque	0.8Nm - 7Lb/in
Solid wire (mm²)	0.75 to 2x2
Flexible wire without terminal (mm²)	0.75 to 2.5x2
Flexible wire without terminal with cap (mm²)	0.75 to 2.5x21

Power circuit

		CL00	CL01	CL02	CL03	CL04	CL05	CL05	CL06	CL07	CL08	CL09	CL10
Three pole version													
Rated thermal current I _{th} at $\theta \leq 55^\circ\text{C}$ (A)		25	25	32	45	60	60	-	90	110	110	140	140
Rated operational current I _e AC-3 (A)		9	12	18	25	32	50	-	50	65	80	95	105
Rated operational voltage U _e (V)		690	690	690	690	690	690	-	690	690	690	690	690
Four pole version (4NO and 2NO+2NC)													
Rated thermal current I _{th} at $\theta \leq 55^\circ\text{C}$ (A)		-	25	32	45	60	-	90	-	110	110	140	-
Rated operational voltage U _e (V)		-	690	690	690	690	-	690	-	690	690	690	-
Three and four pole version													
Rated insulation voltage U _i (V)		1000	1000	1000	1000	1000	1000	1000	1000	1000	1000	1000	1000
Maximum continuous current AC-1 (A)		25	25	32	45	60	60	90	90	110	110	140	140
Frequency limits (Hz)		25.400	25.400	25.400	25.400	25.400	25.400	25.400	25.400	25.400	25.400	25.400	25.400
Making capacity (RMS) (IEC 947) (A)		450	450	450	450	550	550	1000	1000	1000	1000	1280	1280
Breaking capacity (RMS) (IEC 947)													
U _e ≤ 400V (A)		250	250	250	350	450	450	920	920	920	920	1050	1050
U _e = 500V (A)		250	250	250	320	450	450	920	920	920	920	1050	1050
U _e = 690V (A)		130	130	130	170	205	205	780	780	780	780	950	950
Short-time current													
1 sec. (A)		455	455	570	630	1010	1265	1580	1580	2530	2530	3300	3300
5 sec. (A)		205	205	254	280	450	450	565	710	1130	1130	1485	1485
10 sec. (A)		144	144	180	200	320	400	500	500	800	800	1050	1050
30 sec. (A)		85	85	104	115	185	230	290	290	460	460	600	600
1 min. (A)		60	60	74	80	130	165	205	205	325	325	430	430
3 min. (A)		35	35	46	50	90	100	120	120	185	185	250	250
Recovery time (min.)		10	10	10	10	10	10	10	10	10	10	10	10
Protec. against short-circuit with fuses without TOR													
Coordination type "1"													
gL/gG (A)		50	50	63	63	100	125	200	200	200	200	250	250
Coordination type "2"													
gL-gG (A)		25	35	35	50	63	80	100	100	125	125	160	200
Without welding													
gL-gG (A)		10	10	25	35	35	50	80	80	100	100	140	160
Impedance per pole (mΩ)		2.35	2.35	2.41	1.65	1.28	0.95	0.85	0.85	0.86	0.86	0.76	0.76
Power dissipation per pole													
AC-1 (W)		1.47	1.47	2.46	3.34	4.6	3.42	6.89	6.86	10.40	10.40	14.89	14.89
AC-3 (W)		0.19	0.34	0.78	1.03	1.31	1.52	1.36	2.12	3.63	5.5	6.86	8.37
Insulation resistance													
Between adjacent poles (MΩ)		>10	>10	>10	>10	>10	>10	>10	>10	>10	>10	>10	>10
Between poles and earth (MΩ)		>10	>10	>10	>10	>10	>10	>10	>10	>10	>10	>10	>10
Between input and output (MΩ)		>10	>10	>10	>10	>10	>10	>10	>10	>10	>10	>10	>10

Control circuit

		CL00 ... CL03	CL04 ... CL05_3..	CL05_4 ... CL08	CL09 ... CL10
Alternating current					
Rated insulation voltage U_i	(V)	1000	1000	1000	1000
Standard voltages U_s 50Hz	(V)	24...690	24...690	24...690	24...690
Standard voltages U_s 60Hz	(V)	24...600	24...600	24...600	24...600
Voltage operating limits monofrequency coils					
Operating	$\times U_s$	0.8...1.1	0.8...1.1	0.8...1.1	0.8...1.1
Pick-up	$\times U_s$	0.6...0.8	0.65...0.8	0.65...0.8	0.65...0.8
Seal	$\times U_s$	0.35...0.55	0.4...0.6	0.4...0.6	0.4...0.6
Voltage operating limits 50/60Hz coils					
Operating 50Hz	$\times U_s$	0.8...1.1	0.8...1.1	0.8...1.1	0.8...1.1
Operating 60Hz	$\times U_s$	0.85...1.1	0.85...1.1	0.85...1.1	0.85...1.1
Pick-up 50Hz	$\times U_s$	0.5...0.8	0.6...0.8	0.6...0.8	0.6...0.8
Pick-up 60Hz	$\times U_s$	0.65...0.85	0.7...0.85	0.7...0.85	0.7...0.85
Seal 50Hz	$\times U_s$	0.3...0.55	0.35...0.60	0.35...0.60	0.35...0.60
Seal 60Hz	$\times U_s$	0.35...0.65	0.4...0.6	0.4...0.6	0.4...0.6
Consumption monofrequency coils					
Magnetic circuit closed	(VA)	6	9	15.5	15.5
Magnetic circuit opened (VA)		48	88	190	190
Consumption bifrequency coils					
Magnetic circuit closed (50Hz/60Hz)	(VA)	6.8 / 5.6	11.4 / 9.5	20 / 16.6	20 / 16.6
Magnetic circuit opened (50Hz/60Hz)	(VA)	53 / 44	120 / 100	245 / 204	245 / 204
Thermal power dissipation (50Hz/60Hz)	(W)	2.2 / 1.8	3.2 / 2.6	5.2 / 4.3	5.2 / 4.3
Power factor					
Magnetic circuit closed	$\cos \varphi$	0.33	0.28	0.26	0.26
Magnetic circuit opened	$\cos \varphi$	0.84	0.73	0.54	0.54
Opening and closing times					
Values between +10% U_s and -20% U_s					
Time on energisation (NO)	(ms)	6...20	7...25	9...35	9...35
Time on de-energisation (NO)	(ms)	6...13	5...25	9...15	9...15
Values at U_s					
Time on energisation (NO)	(ms)	8...20	10...19	15...30	15...30
Time on de-energisation (NO)	(ms)	6...13	5...25	9...15	9...15
Mechanical endurance					
Monofrequency coils	10^6 ops.	15	15	15	15
Bifrequency coils (at 50Hz)	10^6 ops.	10	10	8	8
Maximum rate					
Monofrequency coils. No load	ops./h	9000	9000	9000	5000
AC-1 at rated power	ops./h	1200	1200	1200	1200
AC-2 at rated power	ops./h	1000	1000	1000	750
AC-3 at rated power	ops./h	1200	1200	1200	600
AC-4 at rated power	ops./h	360	360	200	200
Bifrequency coils. No load	ops./h	3600	3600	3600	3600

		CL00D ... CL03D		Coils with electronic module		Coils with wide voltage range		
		CL00D ... CL03D	CL04D ... CL05D3	CL05E ... CL08E	CL09E ... CL10E	CL00D..W ... CL03D..W	CL04D..W ... CL05D3..W	CL05D4..W ... CL10D..W
Direct current								
Rated insulation voltage U_i	(V)	1000	1000	1000	1000	1000	1000	1000
Standard voltages U_s	(V)	12...440	12...440	24...440	24...440	12...440	12...440	12...440
Operating limits								
Operating	$\times U_s$	0.8...1.1	0.8...1.1	0.8...1.1	0.8...1.1	0.7...1.3	0.7...1.3	0.7...1.3
Pick-up	$\times U_s$	0.45...0.65	0.45...0.65	0.70...0.80	0.70...0.80	0.45...0.55	0.45...0.55	0.45...0.55
Drop-out	$\times U_s$	0.15...0.3	0.15...0.3	0.4...0.6	0.4...0.6	0.15...0.3	0.15...0.3	0.15...0.3
Consumption								
Magnetic circuit closed	(W)	5.5	8	10	10	6.5	10.4	20
Magnetic circuit opened (W)		5.5	8	170	170	6.5	10.4	20
Opening and closing times								
Values between +10% U_s and -20% U_s								
Time on energisation (NO)	(ms)	35...65	35...70	60...80	60...80	26...55	30...65	64...133
Time on de-energisation (NO)	(ms)	6...15	40...65	40...50	40...50	6...15	5...10	20...23
Values at U_s								
Time on energisation (NO)	(ms)	35...45	40...55	50...60	50...60	35...45	40...55	75...95
Time on de-energisation (NO)	(ms)	7...12	30...65	55...60	55...60	7...12	6...8	20...22
Mechanical endurance								
No load	10^6 ops.	15	15	12	12	15	15	12
Maximum rate								
No load	ops./h	3600	3600	2500	2500	3600	3600	3600
AC1 and AC3 at rated power	ops./h	1200	1200	1200	600	1200	1200	1200
AC4 at rated power	ops./h	360	360	200	200	360	360	200



Electrical endurance

Mixed category AC4 / AC3

Electrical endurance for mixed category (AC-3/AC-4) is calculated with the following formula:

$$\text{Electrical endurance (AC-3/AC-4)} = \frac{\text{Electrical endurance (AC-3)}}{1 + \frac{\% \text{ oper AC-4}}{100}} \times \left(\frac{\text{Elec.endur. (AC-3)}}{\text{Elec.endur.(AC-4)} - 1} \right)$$

Category AC1⁽¹⁾

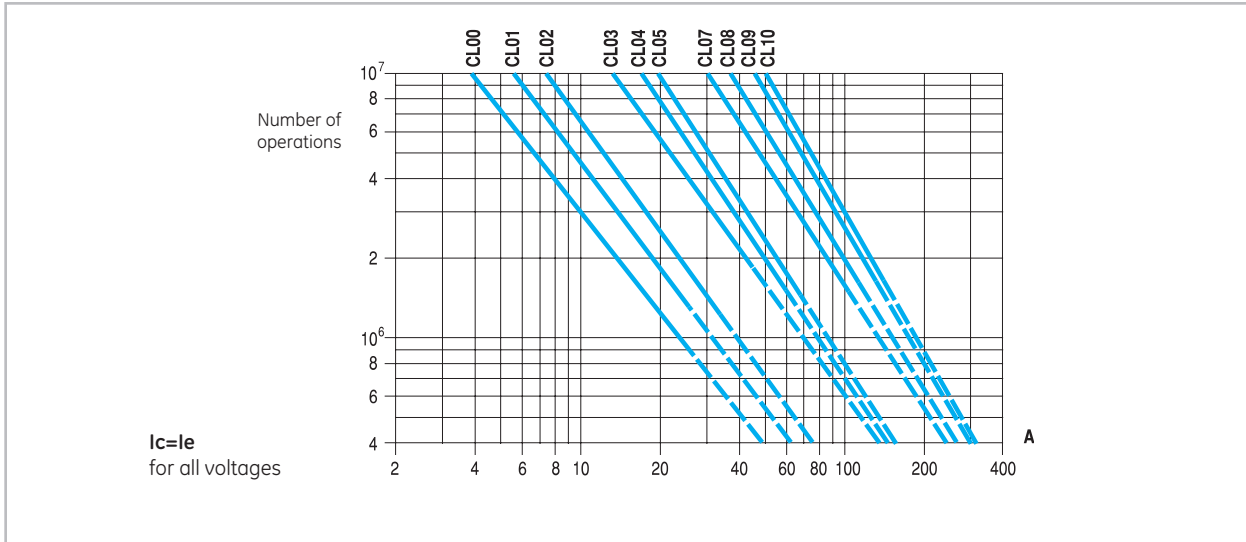

(1) AC1 application current shall not exceed Ith current of the contactor

Category AC2

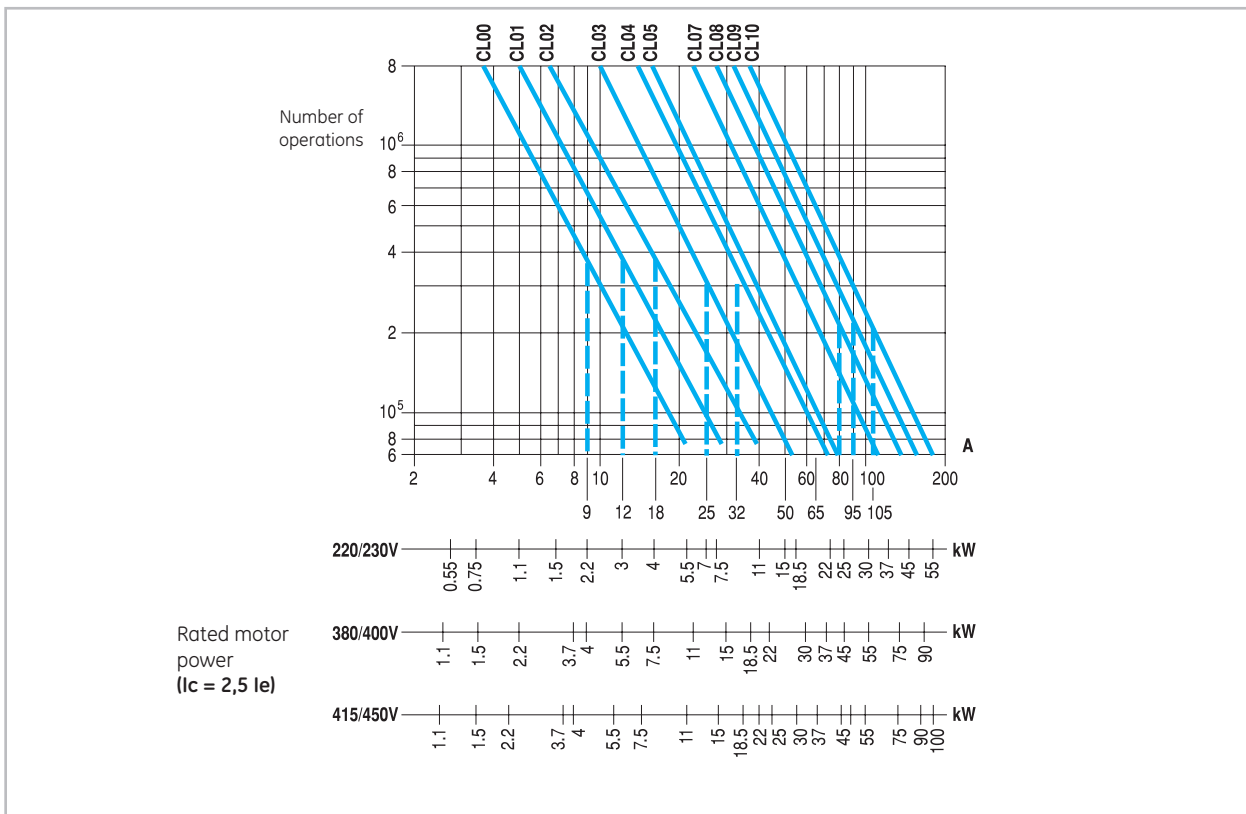

Category AC3

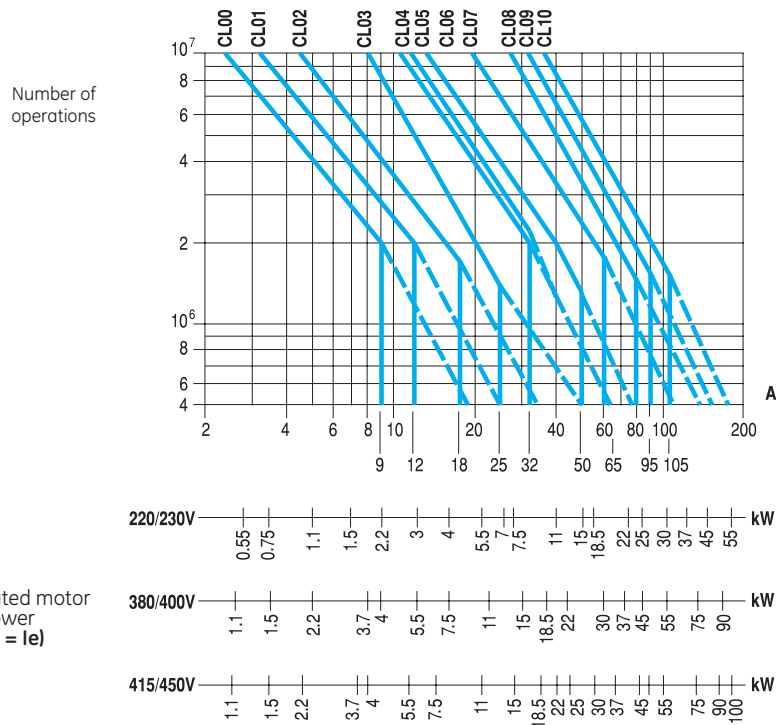

Category AC4

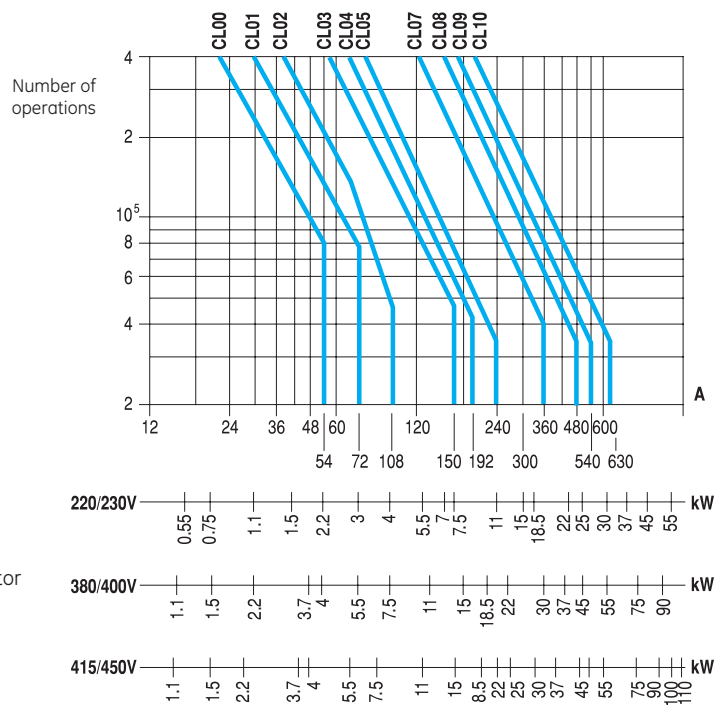

Internal auxiliary contacts

			CL00 ... CL02		CL04	
Rated insulation voltage U_i according to IEC 60947	(V)		1000		1000	
Rated thermal current I_{th} at $\theta \leq 55^\circ\text{C}$	(A)		20		20	
Making capacity (r.m.s.) acc. to IEC 60947						
AC-15	$U_e \leq 400\text{V}, 50/60\text{Hz}$	(A)	250		250	
DC-13	$U_e \leq 220\text{V DC}$	(A)	250		250	
Breaking capacity (r.m.s.) acc. to IEC 60947						
AC-15	$U_e \leq 400\text{V}, 50/60\text{Hz}$	(A)	250		250	
DC-13	$U_e \leq 220\text{V DC}$	(A)	2		2	
AC-15	Rated voltage and current U_e - I_e	according to IEC	110/120V-10A	220/230V-10A	110/120V-10A	230/220V-10A
			400/380V-6A	415/450V-5A	400/380V-6A	415/450V-5A
			500V-4A	690/660V-2A	500V-4A	690/660V-2A
			A600		A600	
DC-13	Rated voltage and current U_e - I_e	according to IEC	24V-6A	48V-4A	24V-6A	48V-4A
			110V-2A	220V-0.7A	110V-2A	220V-0.7A
			440V-0.35A		440V-0.35A	
			P600		P600	
Electrical endurance		ops.	10^6		10^6	
Minimum operational power (operational safety)			17V - 5mA		17V - 5mA	
Short-circuit protect.	Max.fuse class gl-gG without welding	(A)	10		10	
Insulation resistance	Between contacts	(M Ω)	> 10		> 10	
	Between contacts and earth	(M Ω)	> 10		> 10	
	Between input and output	(M Ω)	> 10		> 10	
Guaranteed no overlap between NO and NC contacts						
	Space	(mm)	1.3		2.6	
	Time	(ms)	1.5		1.5	
Impedance of the contacts		(m Ω)	1.28		1.28	

Auxiliary contact blocks

			Instantaneous BCLF..., BCRF..., BCLL..., BRLL...		Timed blocks BTLF..., BTRF...	
Rated insulation voltage U_i according to IEC 60947	(V)		1000		1000	
Rated thermal current I_{th} at $\theta \leq 55^\circ\text{C}$	(A)		10		10	
Making capacity (I _{eff}) according to IEC 60947						
AC-15	$U_e \leq 400\text{V}, 50/60\text{Hz}$	(A)	90		90	
DC-13	$U_e \leq 220\text{V DC}$	(A)	90		90	
Breaking capacity (I _{eff}) according to IEC 60947						
AC-15	$U_e \leq 400\text{V}, 50/60\text{Hz}$	(A)	60		60	
DC-13	$U_e \leq 220\text{V DC}$	(A)	0.95		0.95	
AC-15	Rated voltage and current U_e - I_e	according to IEC	120/110V-6A	230/220V-6A	120/110V-6A	230/220V-6A
			400/380V-4A	440/415V-3.5A	400/380V-4A	440/415V-3.5A
			500V-2.5A	690/660V-1.5A	500V-2.5A	690/660V-1.5A
			A600		A600	
DC-13	Rated voltage and current U_e - I_e	according to IEC	24V-4A	48V-2A	24V-4A	48V-2A
			110V-0.7A	220V-0.3A	110V-0.7A	220V-0.3A
			440V-0.15A		440V-0.15A	
			Q600		Q600	
Electrical endurance		10^6 ops.	1		1	
Mechanical endurance		10^6 ops.	10		5	
Minimum operational current (operational safety)						
Short-circuit protect.	Max.fuse class gl-gG without welding	(A)	10		10	
Insulation resistance	Between contacts	(M Ω)	> 10		> 10	
	Between contacts and earth	(M Ω)	> 10		> 10	
	Between input and output	(M Ω)	> 10		> 10	
Guaranteed no overlap between NO and NC contacts						
	Space	(mm)	1.3		1.3	
	Time	(ms)	1.5		5	
Impedance of the contacts		(m Ω)	1.28		1.28	
Timing (ambient temperature between -25°C and $+55^\circ\text{C}$)						
	Accuracy		-		$\pm 5\%$	

Mechanical latch blocks

	RMLF...	
Rated insulation voltage U_i	1000V	
Standard voltages U_s : 50 to 60Hz and DC	24...690V	
Operating limits	0.75...1.1 x U_s	
Consumption for unlatching (auto cut-out)		
24 to 72V	210W / VA	
110 to 440V	130W / VA	
Electrical unlatching control ⁽¹⁾		
Minimum impulse	10ms	
Maintained	auto cut-out by integral contact	
Manual unlatching control	by local push-button	
Electrical making control		
Minimum pulse	40ms auto cut-out by integral contact	
Manual making control	by local push-button	
Auxiliary contact NC		
Utilisation AC-15 according to IEC	120V - 6A 230V/220V - 4A 400V/380V - 2.5A	500V - 1.5A 690V/660V - 1A
according to UL/CSA	A600	
Utilisation DC-13 according to IEC	24V - 3A 48V - 1.5A 110V - 0.6A	220V - 0.3A 400V - 0.15A
according to UL/CSA	Q600	
Mechanical endurance		
CL00...CL05*3	3 million (1200 ops./h)	
CL05*4...CL10	0.1 million (300 ops./h)	
Wiring diagram Alternating current		
Alternating current / Direct current		

(1) The contactor coil and the unlatch control must not be energised simultaneously

Terminal capacity

	Terminal: screw BCLF, BCLL, BTLF y RMLF	Terminal: ring terminal BCRF, BTRF
Solid	2 x 0.5 to 2.5 or 1 x 4	
Stranded and finely stranded without end sleeve	2 x 0.5 to 2.5 or 1 x 4	
Finely stranded with end sleeve	2 x 0.5 to 2.5 or 1 x 4	
AWG wires, solid and stranded	12 - 22 AWG 75°C	
Tightening torque	1.1 Nm / 10 Lb x in.	
	Ring terminal $\varnothing i$	3.6 min.
	A	6.5 max.
	Tightening torque	0.8Nm / 7 Lb x in.

Contact sequence

	Basic contactor	Auxiliary contact blocks Front mounted		Auxiliary contact blocks Lateral mounted			
		BCLF 10 BCRF 10	BCLF 01 BCRF 01	BCLL 20 BRLL 20	BCLL 11 BRLL 11		
Three pole contactors 3 NO	CL00... CL01... CL02...						
	CL03...						
	CL04...						
	CL05...						
	CL06...						
	CL07... CL08...						
	CL09...						
	CL10...						
	Four pole contactors 4 NO	CL01... CL02...					
		CL03... CL04...					
CL05...							
CL07...							
CL09...							
Four pole contactors 2 NO + 2 NC	CL01... CL02...						
	CL03... CL04...						
	CL05...						
	CL07... CL08...						



Terminal numbering

Three-pole and four-pole AC contactors

CL00A310 ... CL10A300
 CL03D300 ... CL05D300
 CL07E300 ... CL10E300

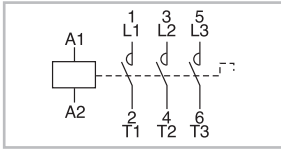

CL00_310 ... CL02_310
 CL04_310

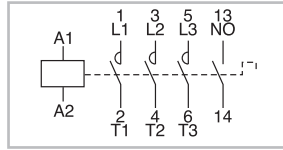

CL00_301 ... CL02_301
 CL04_301

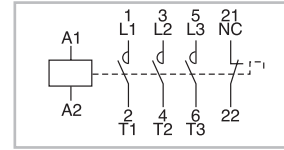

CL05A311 ... CL10A311

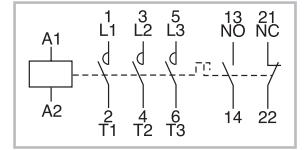

CL03_300

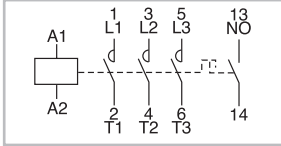

CL00A400 ... CL08A400
 CL01D400 ... CL04D400
 CL05E400 ... CL09E400

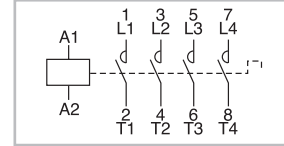

CL01AB00 ... CL08AB00
 CL01DB00 ... CL04DB00
 CL05EB00 ... CL08EB00

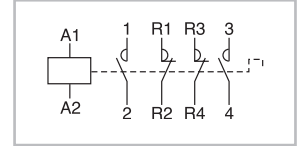

Auxiliary contact blocks. Front mounting

BC_F10

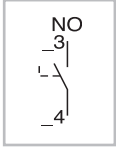

BC_F01

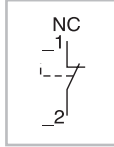

BCLF10G

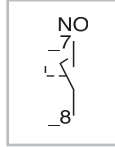

BCLF01G

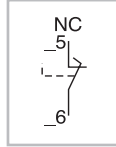

Auxiliary contact blocks. Lateral mounting

BCLL20

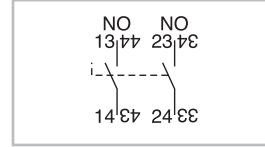

BCLL11

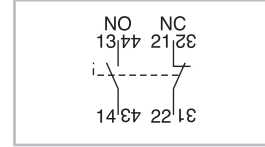

BRL20

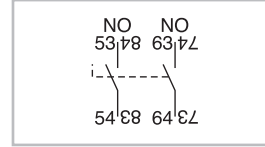

BRL11

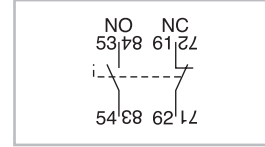

Pneumatic timer blocks

BT_F_C

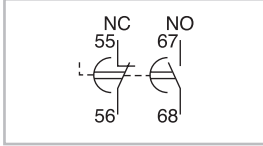

BT_F_D

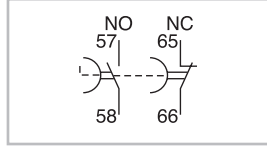

Electronic timer blocks

BETL_C

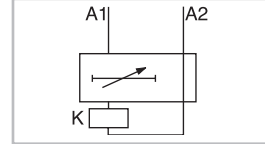

BETL_D

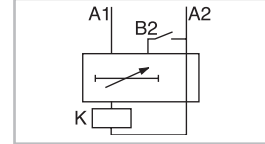

Mechanical and mechanical/electrical interlock

BELA



BELA02

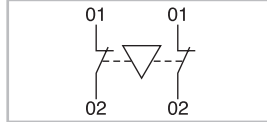

Voltage suppressor blocks

BSLR2, BSLR3

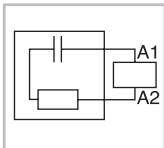

BSLDZ

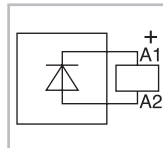

BSLV3

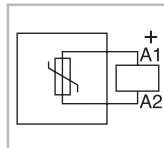

Mechanical latch block

RMLF

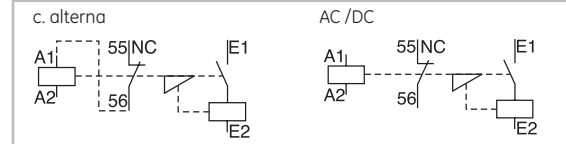











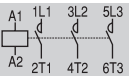

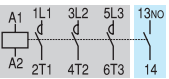

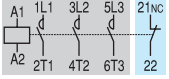

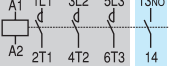

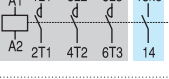

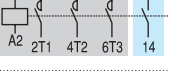

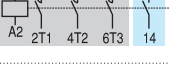

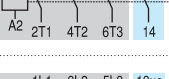

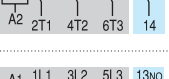

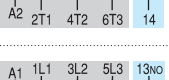

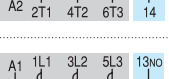

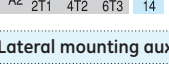
Terminal numbering according to EN 50012

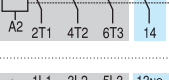
	Auxiliary contacts		Possible basic contactors + Auxiliary contacts blocks to be added	
	Combination	Diagram		
	Description	NO	NC	
Without auxiliary contact blocks				
	10E	1	0	CL00_310... - CL04_310...
	01E	0	1	CL00_301... - CL04_301...
Front mounting auxiliary contact blocks with one contact each				
	11E	1	1	CL00_310... - CL04_310... + BC_F01
	21E	2	1	CL00_310... - CL04_310... + BC_F01 + BC_F10
	12E	1	2	CL00_310... - CL04_310... + BC_F01 + BC_F01
	31E	3	1	CL00_310... - CL04_310... + BC_F01 + BC_F10 + BC_F10
	41E	4	1	CL00_310... - CL04_310... + BC_F01 + BC_F10 + BC_F10 + BC_F10
	22E	2	2	CL00_310... - CL04_310... + BC_F01 + BC_F01 + BC_F10
	32E	3	2	CL00_310... - CL04_310... + BC_F01 + BC_F01 + BC_F10 + BC_F10
	13E	1	3	CL00_310... - CL04_310... + BC_F01 + BC_F01 + BC_F01
	23E	2	3	CL00_310... - CL04_310... + BC_F01 + BC_F01 + BC_F01 + BC_F10
Lateral mounting auxiliary contact blocks with two contacts each				
	11E	1	1	CL03_300... - CL05_300... + BCLL11
	31E	3	1	CL03_300... - CL05_300... + BCLL11 + BCLL20
	22E	2	2	CL00_310... - CL05_300... + BCLL11 + BCLL11

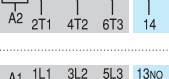
The maximum number of auxiliary contacts is 4 for CL00 to CL03, 6 for CL04 and 8 for CL05, CL06 to CL10. When using the pneumatic BTLF-block, these numbers are reduced to two, resp. four. (2 for CL00 to CL03, 4 for CL04, etc.)

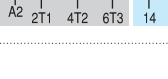
Terminal numbering according to EN 50012 (continued)

		Auxiliary contacts		Possible basic contactors		
		Combination			+ Auxiliary contacts blocks to be added	
		Description				
Without auxiliary contact blocks						
					 CL03_300... - CL05_300...	 CL06_300... - CL10_300...
Front mounting auxiliary contact blocks with one contact each						
	10E	1	0	 CL03_300... - CL05_300... + BC_F10	 CL06_300... - CL10_300... + BC_F10	
	01E	0	1	 CL03_300... - CL05_300... + BC_F01	 CL06_300... - CL10_300... + BC_F01	
	11E	1	1	 CL03_300... - CL05_300... + BC_F10 + BC_F01	 CL06_300... - CL10_300... + BC_F10 + BC_F01	
	21E	2	1	 CL03_300... - CL05_300... + BC_F10 + BC_F01 + BC_F10	 CL06_300... - CL10_300... + BC_F10 + BC_F01 + BC_F10	
	12E	1	2	 CL03_300... - CL05_300... + BC_F10 + BC_F01 + BC_F01	 CL06_300... - CL10_300... + BC_F10 + BC_F01 + BC_F01	
	31E	3	1	 CL03_300... - CL05_300... + BC_F10 + BC_F01 + BC_F10 + BC_F10	 CL06_300... - CL10_300... + BC_F10 + BC_F01 + BC_F10 + BC_F10	
	41E	4	1	 CL06_300... - CL10_300... + BC_F10 + BC_F01 + BC_F10 + BC_F10 + BC_F10		
	22E	2	2	 CL03_300... - CL05_300... + BC_F10 + BC_F01 + BC_F01 + BC_F10	 CL06_300... - CL10_300... + BC_F10 + BC_F01 + BC_F01 + BC_F10	
	32E	3	2	 CL06_300... - CL10_300... + BC_F10 + BC_F01 + BC_F01 + BC_F10 + BC_F10		
	13E	1	3	 CL03_300... - CL05_300... + BC_F10 + BC_F01 + BC_F01 + BC_F01	 CL06_300... - CL10_300... + BC_F10 + BC_F01 + BC_F01 + BC_F01	
	23E	2	3	 CL06_300... - CL10_300... + BC_F10 + BC_F01 + BC_F01 + BC_F10 + BC_F10		
Lateral mounting auxiliary contact blocks with two contacts each						
	11E	1	1	 CL03_300... - CL05_300... + BCLL11	 CL06_300... - CL10_300... + BCLL11	
	31E	3	1	 CL03_300... - CL05_300... + BCLL11 + BCLL20	 CL06_300... - CL10_300... + BCLL11 + BCLL20	
	22E	2	2	 CL03_300... - CL05_300... + BCLL11 + BCLL11	 CL06_300... - CL10_300... + BCLL11 + BCLL11	

Conformity to standards

IEC/EN 60947-1	NF C 63-110	BS 5424 & 775
IEC/EN 60947-4-1	ASE 1025	NEMA ICS 1
CENELEC HD 419	CSA 22.2/14	VDE 0660/102
UL 508	UNE 20109	
EN 50005		

Approvals/Marking

cULus	RINA	CE
NOM	FI	
Lloyd's Register	Bureau Veritas	

Ambient conditions

Storage temperature	-55°C to +80°C	
Operation temperature	-40°C to +60°C	
Altitude	up to 3000m	Nominal values
	from 3000 up to 4000m	90%le 80%Ue
	from 4000 up to 5000m	80%le 75%Ue

Climatic resistance (IEC 68-2)

Continuous tests 40 / 125 / 56		
Cold (72h)		
Temperature	-40°C	
Dry heat (96h)		
Temperature	+125°C	
Relative humidity	< 50%	
Humid heat (56 days)		
Temperature	+40°C	
Relative humidity	95%	
Cyclical test		
First half-cycle (12h)		
Low temperature	+25°C	
Relative humidity	93%	
Second half-cycle (12h)		
Low temperature	+55°C	
Relative humidity	95%	
Number of consecutive cycles	6	

Terminal capacity and tightening torque

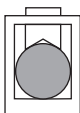
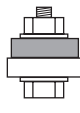
		CK07B	CK75C CK08C	CK08B CK95B	CK10C	CK11C	CK12B	CK13B
	Solid (mm ²)	1.5..95						
	Finely stranded w/end sleeve (mm ²)	2..35						
	Finely stranded w/o end sleeve (mm ²)	2..50						
	Stranded (mm ²)	1.5..95						
	AWG wires (mm ²)	16..00						
Tightening torque (Nm)	8							
	(Lb x in)	70						
	Finely stranded w/end sleeve (mm ²)		1 x 120 2 x 95	1 x 240 2 x 150	2 x 185	2 x 240	-	-
	AWG wires with end sleeve (mm ²)		1 x 300 2 x 107	1 x 500 2 x 300	2 x 350	2 x 500	-	-
	Busbars		2 (25 x 5)	2 (25 x 5)	2 (35 x 10)	2 (35 x 10)	2 (35 x 10)	2 (60 x 10)
	Tightening torque (Nm)		8	23	31.5	31.5	31.5	31.5
		(Lb x in)		70	200	275	275	275

Coil Terminal capacity and tightening torque

Tightening torque	0.8Nm - 7Lb/in	
Solid wire (mm ²)	0.75 to 2x2	
Flexible wire without terminal (mm ²)	0.75 to 2.5x2	
Flexible wire without terminal with cap (mm ²)	0.75 to 2.5x21	

Mounting positions

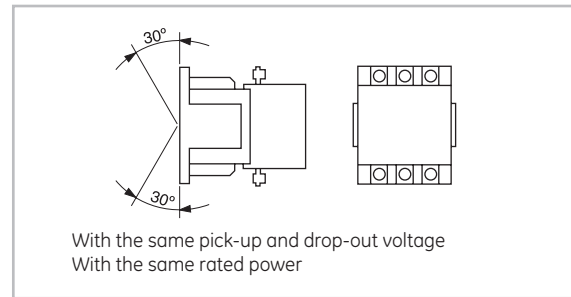

Power circuit

		CK75C	CK08C	CK85B	CK09B	CK95B	CK10C	CK11C	CK12B	CK13B
Three pole contactors										
Rated thermal current I _{th} at θ ≤ 40°C	(A)	250	250	315	315	450	600	700	1000	1250
Rated operational current I _e AC-3	(A)	150	195	205	250	309	420	550	700	825
Rated operational voltage U _e	(V)	1000	1000	1000	1000	1000	1000	1000	1000	1000
Rated insulation voltage U _i	(V)	1000	1000	1000	1000	1000	1000	1000	1000	1000
Maximum continuous current AC-1	(A)	250	250	315	315	450	600	700	1000	1250
Frequency limits	(Hz)	25..400	25..400	25..400	25..400	25..400	25..400	25..400	25..400	25..400
Making capacity (RMS) (IEC 947)	(A)	1850	2200	2500	2500	3700	6500	6500	8400	8250
Breaking capacity (RMS) (IEC 947)										
U _e ≤ 400V	(A)	1600	1850	2000	3500	3500	5600	5600	7300	6600
U _e = 500V	(A)	1600	1850	2000	3500	3500	5600	5600	7000	6600
U _e = 690V	(A)	1000	1200	1660	2200	2200	5000	5000	6700	6000
U _e = 1000V	(A)	350	350	850	1100	1100	3000	3000	3500	3500
Short-time current	1 sec. (A)	2500	2500	4000	5500	5500	7500	7500	9700	11600
	5 sec. (A)	2500	2500	3200	3500	3500	5200	5200	7700	8800
	10 sec. (A)	2300	2300	2400	2500	2500	4000	4000	6100	7350
	30 sec. (A)	1250	1250	1400	1600	1600	2800	2800	4400	5300
	1 min. (A)	900	900	1000	1200	1200	1800	1800	3500	4500
3 min. (A)	600	600	750	900	900	1200	1200	2300	2800	
Recovery time	(min.)	10	10	10	10	10	10	10	10	10
Protec. against short-circuit with fuses without TOR										
Coord. type "1"	gL/gG (A)	355	355	500	500	630	1250	1250	1250	2×800
Coord. type "2"	gL/gG (A)	250	250	315	400	500	630	800	1000	1250
Without welding	gL/gG (A)	200	200	250	315	425	500	630	800	1000
Impedance per pole	(mΩ)	0.30	0.30	0.28	0.28	0.28	0.15	0.13	0.14	0.11
Power dissipation	AC-1 (W)	19	19	27.7	27.7	56.7	54.3	63.7	140	171.8
	per pole AC-3 (W)	6.8	10.3	11.7	17.5	26.7	26.5	45.3	68.6	74.8
Insulation resistance										
Between adjacent poles	(MΩ)	> 10	> 10	> 10	> 10	> 10	> 10	> 10	> 10	> 10
Between poles and earth	(MΩ)	> 10	> 10	> 10	> 10	> 10	> 10	> 10	> 10	> 10
Between input and output	(MΩ)	> 10	> 10	> 10	> 10	> 10	> 10	> 10	> 10	> 10
Four pole contactors										
		CK07B	CK08B		CK09B	CK95B	CK10C	CK11C	CK12B	CK13B
Rated thermal current I _{th} at θ ≤ 40°C	(A)	200	350		400	500	600	700	1000	1250
Rated operational voltage U _e	(V)	690	1000		1000	1000	1000	1000	1000	1000
Rated insulation voltage U _i	(V)	1000	1000		1000	1000	1000	1000	1000	1000
Maximum continuous current AC-1	(A)	200	325		400	500	600	700	1000	1250
Frequency limits	(Hz)	25..400	25..4000		25..400	25..400	25..400	25..400	25..400	25..400
Making capacity (RMS) (IEC 947)	(A)	1150	1850		2500	3700	6500	6500	6700	8250
Breaking capacity (RMS) (IEC 947)										
U _e ≤ 400V	(A)	950	1600		3500	3500	5600	5600	6700	6600
U _e = 500V	(A)	950	1600		3500	3500	5600	5600	6700	6600
U _e = 690V	(A)	800	1000		2200	2200	3500	3500	6000	6000
U _e = 1000V	(A)	-	350		1100	1100	2000	2000	3500	3500
Short-time current	1 sec. (A)	2100	2500		5500	5500	7500	7500	9700	11600
	5 sec. (A)	1500	2500		3500	3500	5200	5200	7700	8800
	10 sec. (A)	1150	2300		2500	2500	4000	4000	6100	7350
	30 sec. (A)	750	1250		1600	1600	2800	2800	4400	5300
	1 min. (A)	550	900		1200	1200	1800	1800	3500	4500
3 min. (A)	350	600		900	900	1200	1200	2300	2800	
Recovery time	min.	10	10		10	10	10	10	10	10
Short-circuit protection with fuse without TOR										
Coord. type "1"	gL/gG (A)	315	500		500	630	1250	1250	1250	2×800
Coord. type "2"	gL/gG (A)	250	400		400	500	630	800	1000	1250
Without welding	gL/gG (A)	200	315		315	425	500	630	800	1000
Impedance per pole	(mΩ)	0.45	0.32		0.28	0.28	0.15	0.13	0.14	0.11
Power dissipation per pole										
AC-1 (W)		18	33.8		44.8	56.7	61.2	68.6	140	171.8
Insulation resistance										
Between adjacent poles	(MΩ)	> 10	> 10		> 10	> 10	> 10	> 10	> 10	> 10
Between poles and earth	(MΩ)	> 10	> 10		> 10	> 10	> 10	> 10	> 10	> 10
Between input and output	(MΩ)	> 10	> 10		> 10	> 10	> 10	> 10	> 10	> 10



Electrical endurance

Mixed category AC4 / AC3

Electrical endurance for mixed category (AC-3/AC-4) is calculated with the following formula:

$$\text{Electrical endurance (AC-3/AC-4)} = \frac{\text{Electrical endurance (AC-3)}}{1 + \frac{\% \text{ oper AC-4}}{100}} \times \left(\frac{\text{Elec.endur. (AC-3)}}{\text{Elec.endur. (AC-4)} - 1} \right)$$

Category AC1

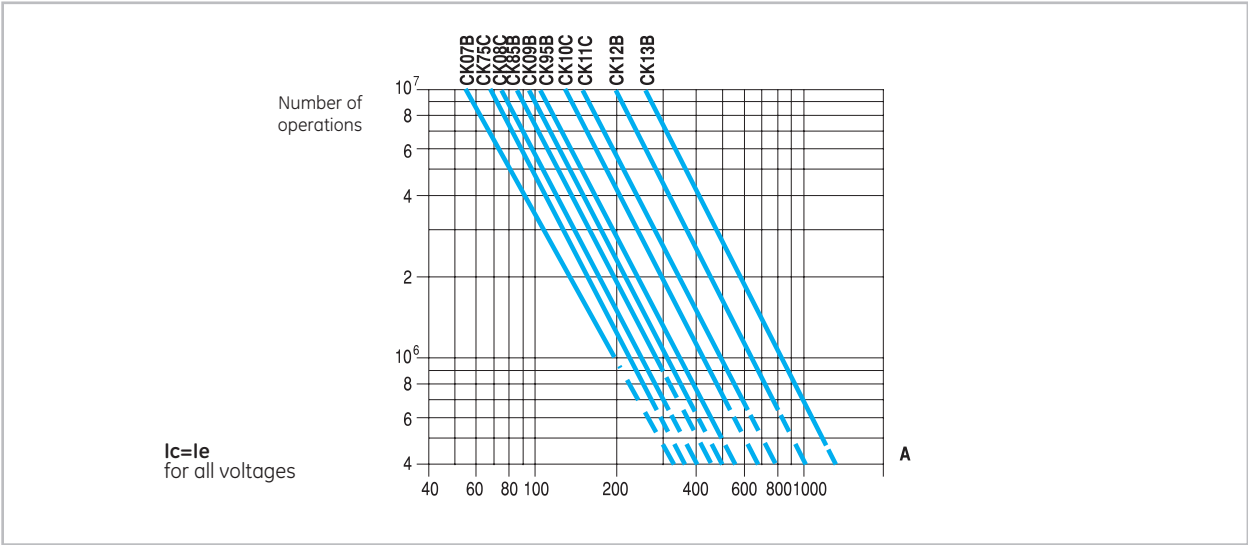

Category AC2

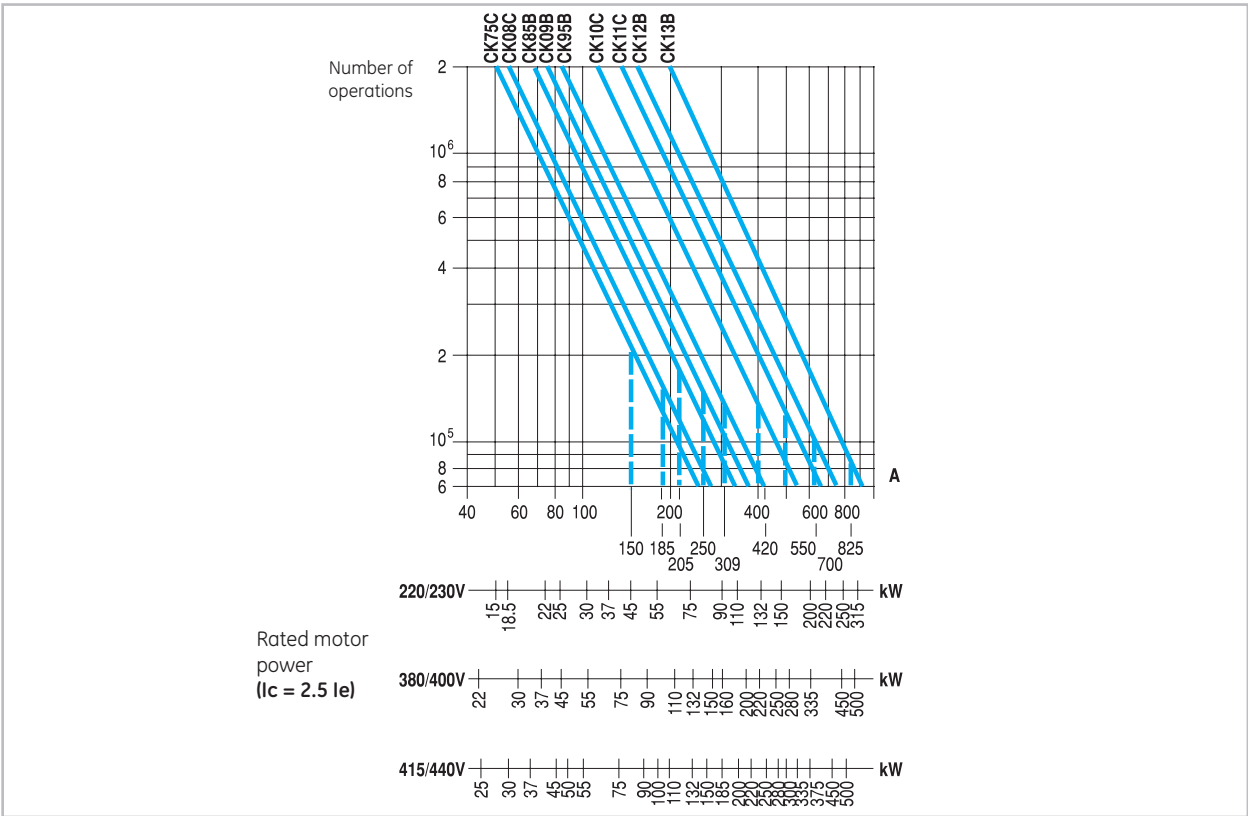

Electrical endurance (continued)

Category AC3

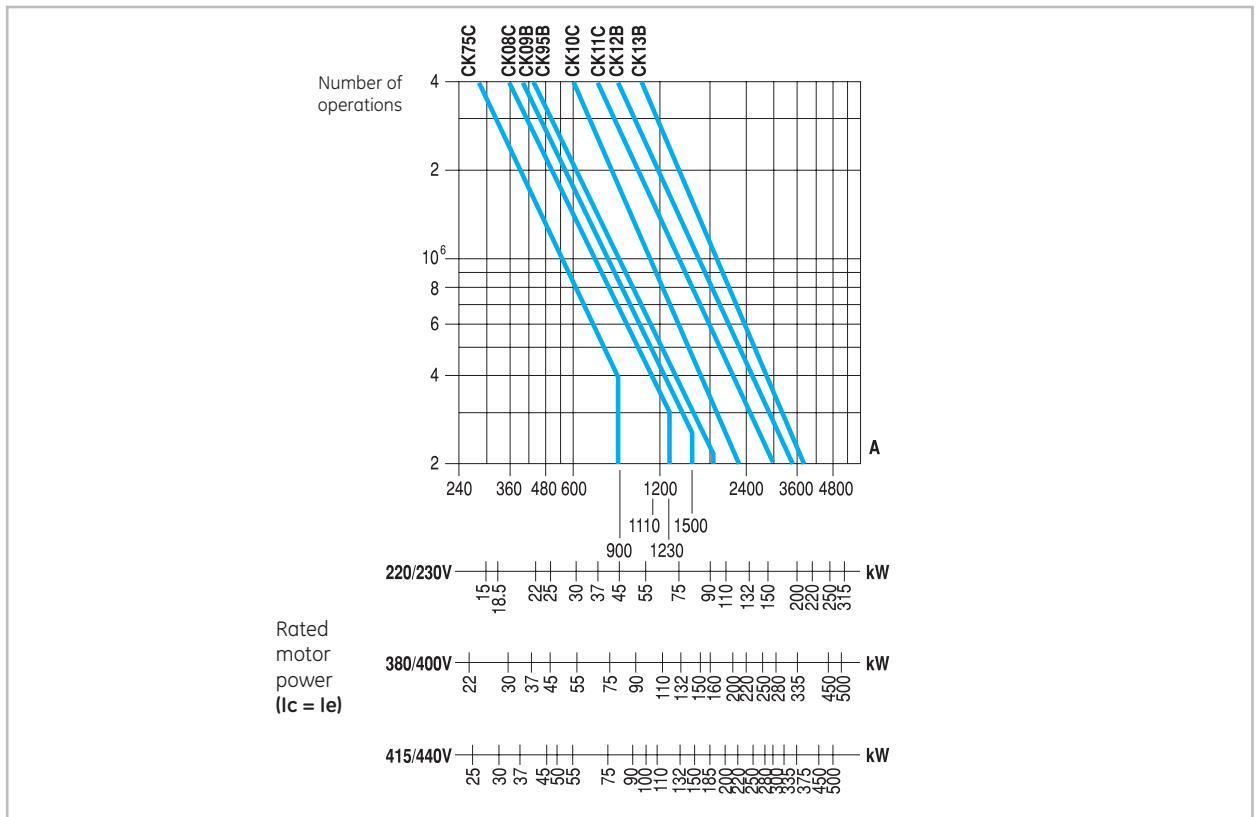

Category AC4

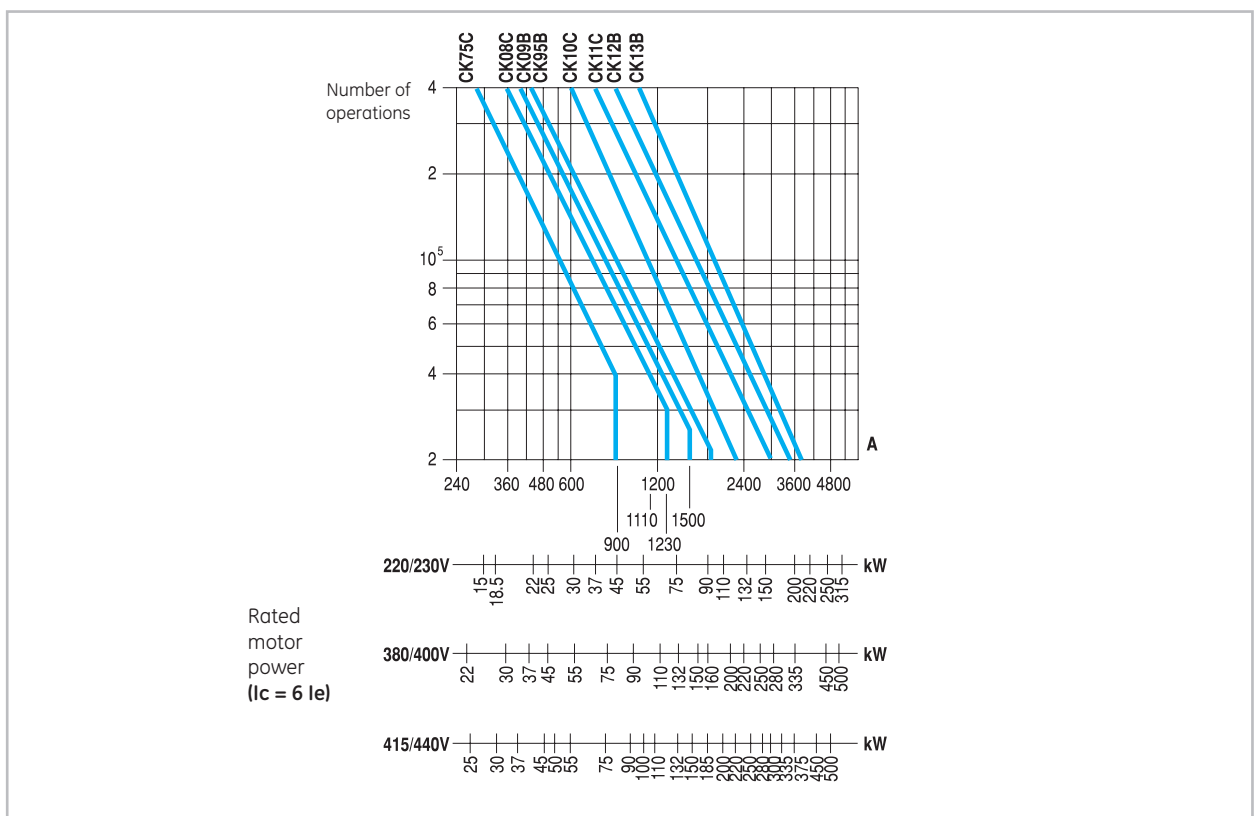

Three pole contactors - Control circuit

Alternating current

		CK75CA CK75CE	CK08CA CK08CE	CK85BA CK85BE	CK09BE	CK95BE	CK10CE	CK11CE	CK12BE	CK12BE	CK13BA
Rated insulation voltage U_i	(V)	1000	1000	1000	1000	1000	1000	1000	1000	1000	1000
Standard voltages U_s (50/60Hz)	(V)	24..690	24..690	24..690	24..690	24..690	24..690	24..690	24..72	100..690	24..440
Operating limits											
Switch-on	xUs	0.8..1.1	0.8..1.1	0.85..1.1	0.85..1.1	0.85..1.1	0.85..1.1	0.85..1.1	0.85..1.1	0.85..1.1	0.8..1.1
Switch-off	xUs	0.2..0.75	0.2..0.75	0.2..0.75	0.2..0.75	0.2..0.75	0.2..0.75	0.2..0.75	0.2..0.75	0.2..0.75	0.25..0.55
Consumption. Monofrequency coils											
Magnetic circuit	CK...A (VA)	42	42	46	-	-	-	-	-	-	6
closed	CK...E (VA)	3.5	3.5	6.3	6.3	6.3	9.1	9.1	10.9	10.9	-
Magnetic circuit	CK...A (VA)	500	500	830	-	-	-	-	-	-	2760
open	CK...E (VA)	212	212	350	350	350	515	515	543	543	-
Power	CK...A (W)	21	21	17	-	-	-	-	-	-	5
dissipation	CK...E (W)	1.8	1.8	3.5	3.5	3.5	4	4	4.5	4.5	-
Consumption. Bifrequency coils											
Magnetic circuit	50Hz (VA)	46	46	60	-	-	-	-	-	-	-
closed (CK...A)	60Hz (VA)	38.3	38.3	50	-	-	-	-	-	-	-
Magnetic circuit	50Hz (VA)	568	568	1082	-	-	-	-	-	-	-
open (CK...A)	60Hz (VA)	473	473	901	-	-	-	-	-	-	-
Power	50Hz (W)	23	23	22.2	-	-	-	-	-	-	-
dissipation (CK...A)	60Hz (W)	19.1	19.1	18.5	-	-	-	-	-	-	-
Power factor											
Magnetic circuit	CK...A (cos ϕ)	0.4	0.4	0.37	-	-	-	-	-	-	approx. 1
closed	CK...E (cos ϕ)	-	-	-	-	-	-	-	-	-	-
Magnetic circuit	CK...A (cos ϕ)	0.6	0.6	0.6	-	-	-	-	-	-	approx. 1
open	CK...E (cos ϕ)	-	-	-	-	-	-	-	-	-	-
Opening and closing times at U_s											
Making time	(ms)	20..25	20..25	36..40	60..70	60..80	80..90	80..90	150..170	70..80	50..55
at excitation (NO)											
Breaking time	(ms)	10..13	10..13	60..80	60..80	60..80	60..80	60..90	60..90	60..90	115..130
at de-energisation (NO)											
Mechanical endurance ⁽¹⁾	10 ⁶ ops	10	10	6.5	6.5	6.5	7.5	7.5	3.5	3.5	3
Maximum rate											
No load	ops/h	2400	2400	2400	1200	1200	900	900	900	900	600
AC-1/AC-3 at rated power	ops/h	600	600	600	600	600	300	300	300	300	120
AC-2 at rated power	ops/h	150	150	150	150	150	120	120	120	120	120
AC-4 at rated power	ops/h	150	150	150	150	150	120	120	120	120	120

(1) Mechanical endurance for e-module is 1 million operations

Direct current - Electronic module

		CK75CE	CK08CE	CK85BE	CK09BE	CK95BE	CK10CE	CK11CE	CK12BE	CK12BE	
Rated insulation voltage U_i	(V)	1000	1000	1000	1000	1000	1000	1000	1000	1000	
Standard voltages U_s (50/60Hz)	(V)	24..500	24..500	24..500	24..500	24..500	24..500	24..500	24..72	100..500	
Operating limits											
Switch-on	xUs	0.8..1.1	0.8..1.1	0.8..1.1	0.8..1.1	0.8..1.1	0.8..1.1	0.8..1.1	0.8..1.1	0.8..1.1	
Switch-off	xUs	0.2..0.75	0.2..0.75	0.2..0.75	0.2..0.75	0.2..0.75	0.2..0.75	0.2..0.75	0.2..0.75	0.2..0.75	
Consumption											
Magnetic circuit closed	(VA)-(W)	2.7-1.6	2.7-1.6	4.3-2.8	4.3-2.8	4.3-2.8	5.4-3.8	5.4-3.8	7.2-4.9	7.2-4.9	
Magnetic circuit open	(VA)-(W)	234-234	234-234	345-345	345-345	345-345	515-515	515-515	545-545	545-545	
Opening and closing times at U_s											
Making time	(ms)	60..70	60..70	60..70	60..70	60..70	80..90	80..90	150..170	70..80	
at excitation (NO contacts)											
Breaking time	(ms)	40..50	40..50	60..80	60..80	60..80	60..80	60..80	60..90	60..90	
at de-energisation (NO contacts)											
Mechanical endurance	10 ⁶ ops.	10	10	6.5	6.5	6.5	7.5	7.5	3.5	3.5	
Maximum rate											
No load	ops/h	1200	1200	1200	1200	1200	900	900	900	900	
AC-3 at rated power	ops/h	600	600	600	600	600	300	300	300	300	
AC-4 at rated power	ops/h	150	150	150	150	150	120	120	120	120	

(1) Mechanical endurance for e-module is 1 million operations

Four pole contactors - Control circuit

Alternating current

		CK07BA CK07BE	CK08BA CK08BE	CK09BE	CK95BE	CK10CE	CK11CE	CK12BE	CK12BE	CK13BA
Rated insulation voltage U_i	(V)	1000	1000	1000	1000	1000	1000	1000	1000	1000
Standard voltages U_s (50/60Hz)	(V)	24..690	24..690	24..690	24..690	24..690	24..690	24..72	100..690	110..440
Operating limits										
Switch-on	xUs	0.85..1.1	0.85..1.1	0.85..1.1	0.85..1.1	0.85..1.1	0.85..1.1	0.85..1.1	0.85..1.1	0.85..1.1
Switch-off	xUs	0.2..0.75	0.2..0.75	0.2..0.75	0.2..0.75	0.2..0.75	0.2..0.6	0.2..0.75	0.2..0.75	0.2..0.75
Consumption. Monofrequency coils										
Magnetic circuit	CK...A (VA)	46	130	-	-	-	-	-	-	6
closed	CK...E (VA)	6.3	10.9	10.9	10.9	5.4	5.4	10.9	10.9	-
Magnetic circuit	CK...A (VA)	830	2860	-	-	-	-	-	-	2760
open	CK...E (VA)	350	543	543	543	515	515	543	543	-
Power	CK...A (W)	17	53	-	-	-	-	-	-	5
dissipation	CK...E (W)	3.5	4.5	4.5	4.5	4	4	4.5	4.5	-
Consumption. Bifrequency coils										
Magnetic circuit	50Hz (VA)	60	159.3	-	-	-	-	-	-	-
closed (CK...A)	60Hz (VA)	50	132.7	-	-	-	-	-	-	-
Magnetic circuit	50Hz (VA)	1082	3509	-	-	-	-	-	-	-
open (CK...A)	60Hz (VA)	901	2924	-	-	-	-	-	-	-
Power	50Hz (W)	22.2	65.3	-	-	-	-	-	-	-
dissipation (CK...A)	60Hz (W)	18.5	54.4	-	-	-	-	-	-	-
Power factor										
Magnetic circuit	CK...A (cos ϕ)	0.37	0.37	-	-	-	-	-	-	approx. 1
closed	CK...E (cos ϕ)	-	-	-	-	-	-	-	-	-
Magnetic circuit	CK...A (cos ϕ)	0.6	0.6	-	-	-	-	-	-	approx. 1
open	CK...E (cos ϕ)	-	-	-	-	-	-	-	-	-
Opening and closing times at Us										
Making time	(ms)	36..40	60..70	70..80	70..80	110..115	80..90	150..170	110..115	50..55
at excitation (NO)										
Breaking time	(ms)	10..15	13..17	70..80	70..80	70..80	70..80	70..80	70..80	70..80
at de-energisation (NO)										
Mechanical endurance	10 ⁶ ops.	10	6.5	6.5	6.5	6.5	6.5	3.5	3.5	3
Maximum rate										
No load	ops/h	2400	900	900	900	900	900	900	900	600
AC-1/AC-3 at rated power	ops/h	600	600	600	600	300	300	300	300	120

Direct current - Electronic module

		CK07BE	CK08BE	CK09BE	CK95BE	CK10CE	CK11CE	CK12BE	CK12BE	-
Rated insulation voltage U_i	(V)	1000	1000	1000	1000	1000	1000	1000	1000	-
Standard voltages U_s	(V)	24..500	24..500	24..500	24..500	24..500	24..500	24..72	110..500	-
Operating limits										
Switch-on	xUs	0.75..1.1	0.8..1.1	0.8..1.1	0.8..1.1	0.8..1.1	0.8..1.1	0.8..1.1	0.8..1.1	-
Switch-off	xUs	0.2..0.75	0.2..0.75	0.2..0.75	0.2..0.75	0.2..0.75	0.2..0.75	0.2..0.75	0.2..0.75	-
Consumption										
Magnetic circuit closed	(VA)-(W)	4.3-2.8	7.2-4.9	7.2-4.9	7.2-4.9	5.4-3.8	5.4-3.8	7.2-4.9	7.2-4.9	-
Magnetic circuit open	(VA)-(W)	345-345	545-545	545-545	545-545	515-515	515-515	545-545	545-545	-
Opening and closing times at Us										
Making time	(ms)	60..70	70..80	70..80	70..80	80..90	80..90	150..170	110..115	-
at excitation (NO contacts)										
Breaking time	(ms)	40..50	70..80	70..80	70..80	60..80	60..80	60..90	60..90	-
at de-energisation (NO contacts)										
Mechanical endurance	10 ⁶ ops.	10	6.5	6.5	6.5	6.5	6.5	3.5	3.5	-
Maximum rate										
No load	ops/h	1200	900	900	900	900	900	900	900	-
AC-3 at rated power	ops/h	600	600	600	600	600	300	300	300	-



Contact sequence

		Basic contactor	Auxiliary contact blocks Lateral mounted	
			BCLL 20 BRLL 20	BCLL 11 BRLL 11
Three-pole contactors 3 NO	CK75C... CK08C...			
	CK85B... CK09B... CK95B...			
	CK10C... CK11C...			
	CK12B... CK13B...			
	CK07B...			
	CK08B... CK09B... CK95B...			
	CK10C... CK11C...			
	CK12B... CK13B...			

Numbering of the terminals

Three pole contactors

CK75C_3_... CK13B_3_

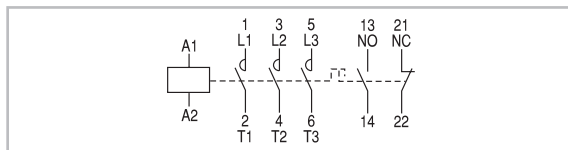

Four pole contactors

CK07B_4_... CK13B_4_

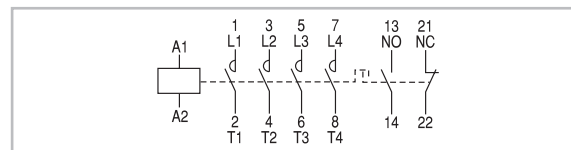

Auxiliary contact blocks. Lateral mounting

BCLL20

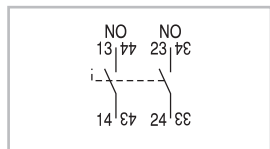

BCLL11

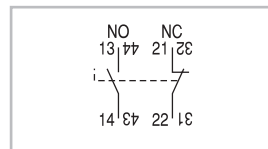

BRLL20

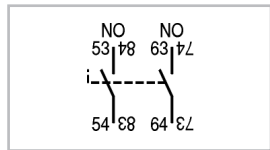

BRLL11

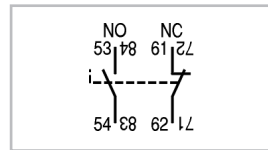

Voltage suppressor block

K/RC...

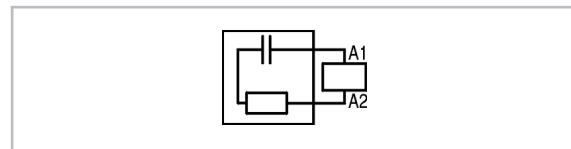

Mechanical interlock

BEKV, BEKVA1, BEKVS1, BEKVH



Everything is under control

Dimensions and weights

EC contactors

Contactors

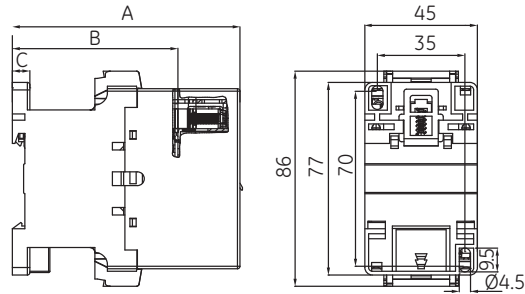

Dimensions in mm	EC09*3 - EC18*3 and ECACA	EC25*3	EC32*3 - EC40*3	EC09D3 - EC18D3 and ECACD	EC25D3	EC32D3 - EC40D3
A	92	97	102	102	110	115
B	66.2	66.2	67.2	76.2	80.2	81.2
C	7	7	7	7	7	7
Weight in g	350	490	530	620	700	740

* A (AC) and E (AC/DC) configurations

Thermal overload relay ECRT1
186 g

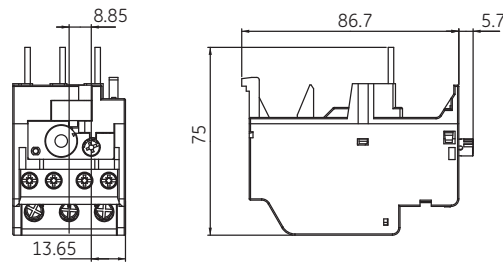

Thermal overload relay ECRT2
194 g

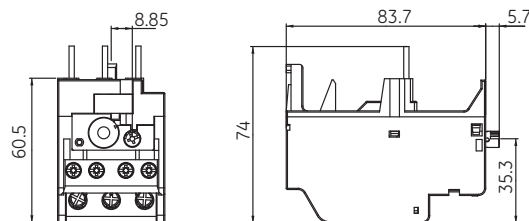

Electronic overload relay RE1
200 g

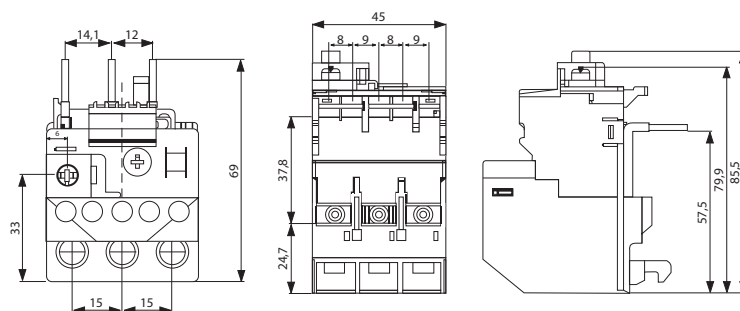

Dimensions in mm (inch = mm x 0.03937) - Weight in kg (lb = kg x 2.2046)



Dimensions and weights

EF contactors

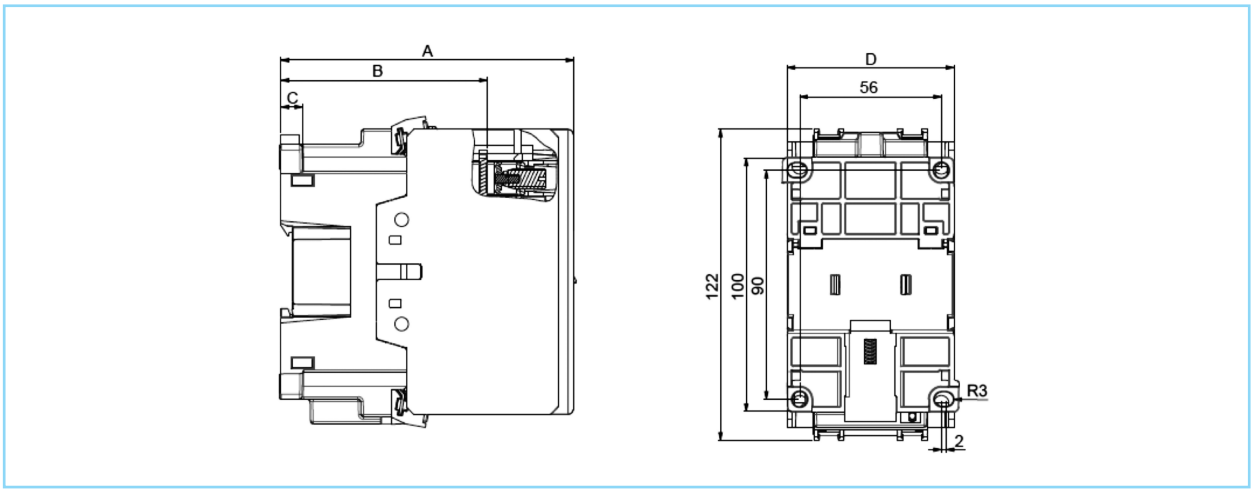

Dimensions in mm	EF50A3 - EF80A3	EF95A3-EF105A3	EF50E3 - EF80E3	EF95E3 - EF105E3
A	117	126	143	153
B	80	85	109	119
C	9	9	9	9
D	65	75	65	75
Weight in g	1125	1468	1270	1613

Thermal overload relay RT2
400 g

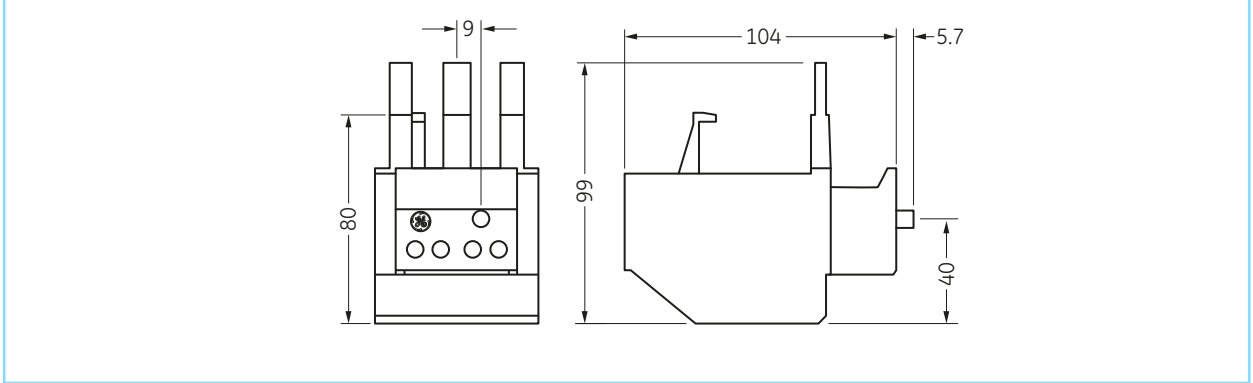

Electronic overload relay RE2
320 g

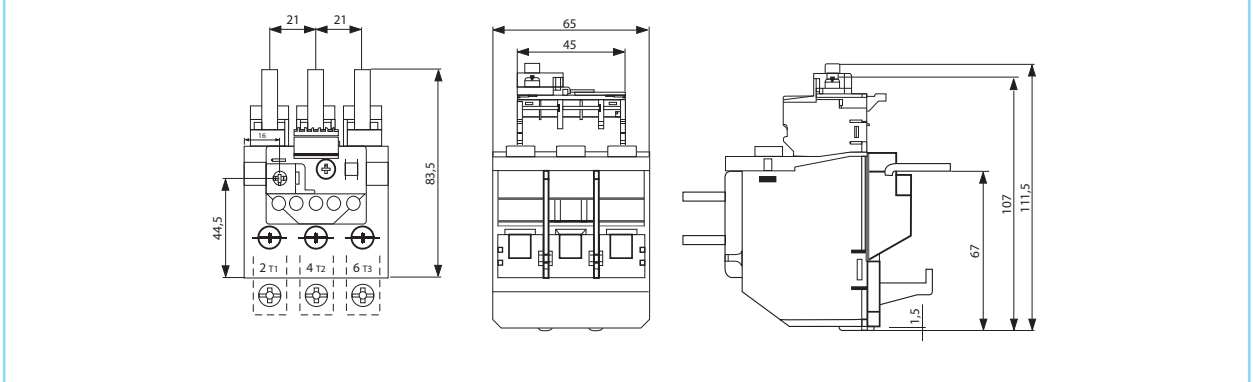

Dimensions in mm (inch = mm x 0.03937) - Weight in kg (lb = kg x 2.2046)



Dimensions and weights

EC contactors

Contactors

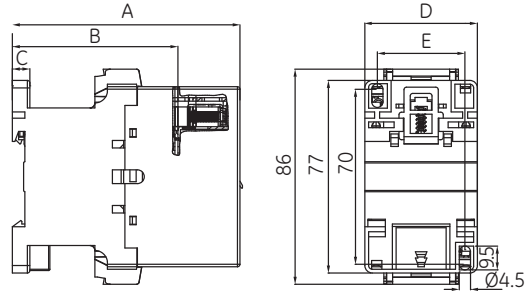

Dimensions in mm	EC12*4 - EC18*4 EC12*B-EC18*B	EC25*4 EC25*B	EC32*4 EC32*B	EC12D4- EC18D4 EC12DB-EC18DB	EC25D4 EC25DB	EC32D4 EC32DB
A	92	97	102	102	110	115
B	66.2	66.2	67.2	76.2	80.2	81.2
C	7	7	7	7	7	7
D	45	45	56	45	45	56
E	35	35	45	35	35	45
Weight in g	350	490	530	620	700	740

* A (AC) and E (AC/DC) configurations

EF contactors

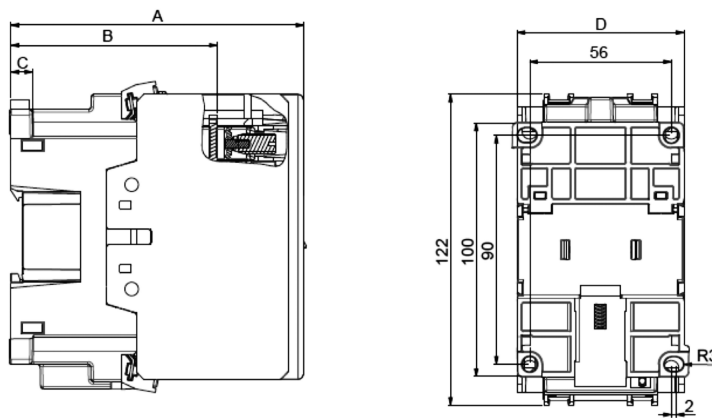

Dimensions in mm	EF40A4 - EF80A4	EF95A4	EF40E4 - EF80E4	EF95E4
A	118.5	126	143	153
B	80	85	109	119
C	9	9	9	9
D	87	96	87	96
Weight in g	1290	1613	1290	1613

Dimensions and weights

EC contactors

Combination of contactor EC09-12-18 (A and E) and thermal overload relay ECRT1

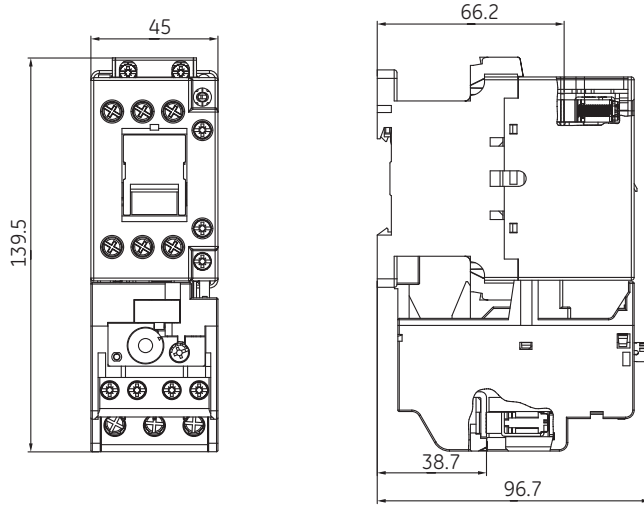

Combination of contactor EC25A and EC25E and thermal overload relay ECRT2

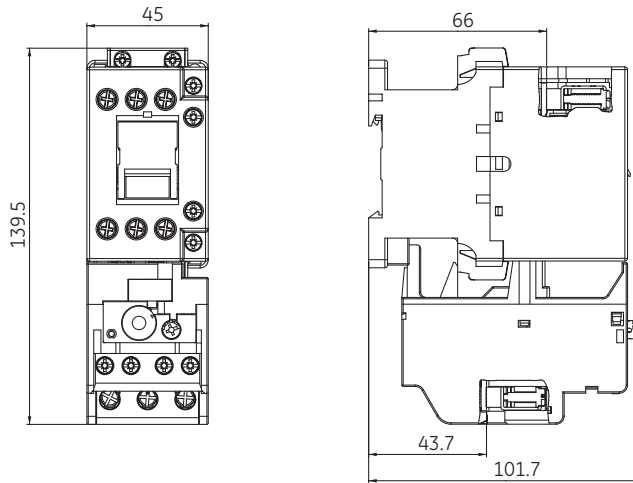

Combination of contactor EC32-40 (A and E) and thermal overload relay ECRT2

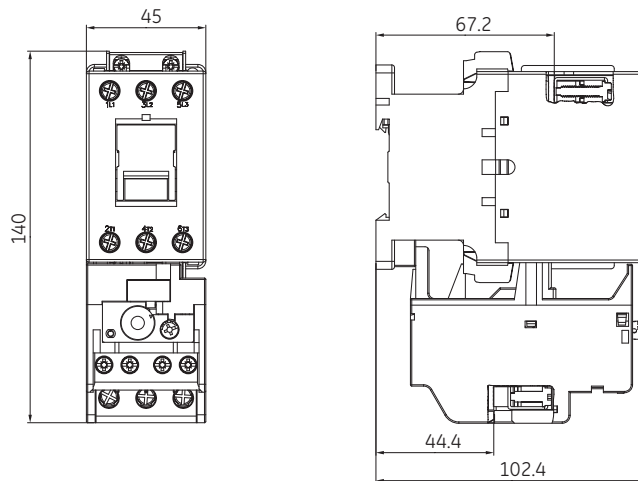

Dimensions in mm (inch = mm x 0.03937) - Weight in kg (lb = kg x 2.2046)



Dimensions and weights

EF contactors

Combination of contactor EF50A3-65A3-80A3 and thermal overload relay RT2

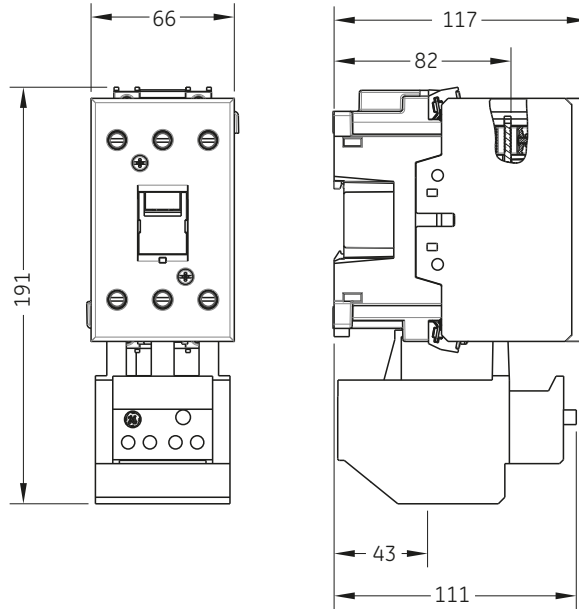

Combination of contactor EF95A3-105A3 and thermal overload relay RT2

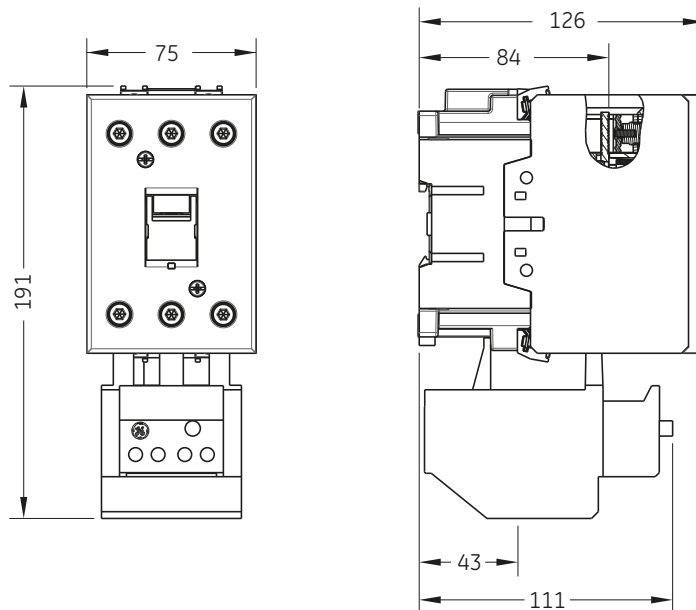

Dimensions in mm (inch = mm x 0.03937) - Weight in kg (lb = kg x 2.2046)

Dimensions and weights

EF contactors

Combination of contactor EF50A3-65A3-80A3 and overload relay RE2

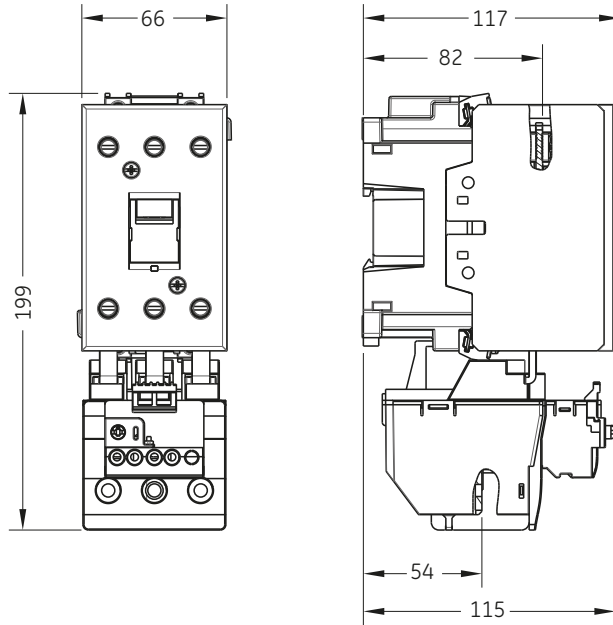

Combination of contactor EF95A3-105A3 and overload relay RE2

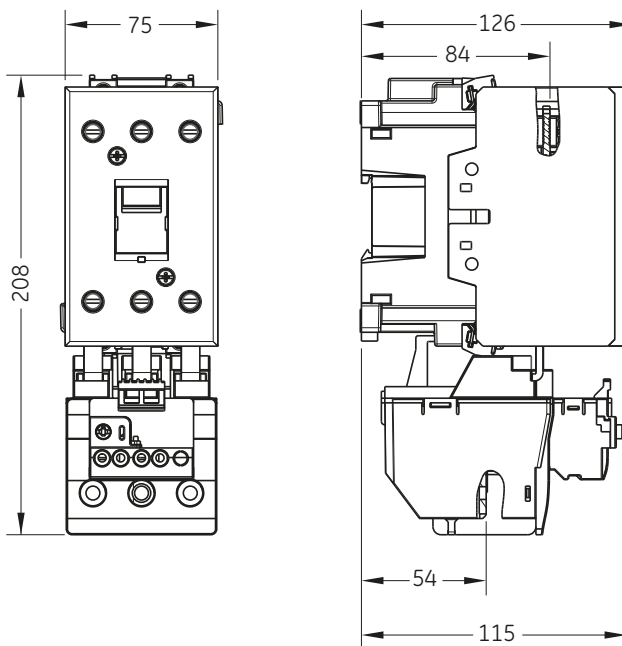

Dimensions in mm (inch = mm x 0.03937) - Weight in kg (lb = kg x 2.2046)

Dimensions and weights

EC contactors

Frontal auxiliary contact block 2P ECFA2S
42 g

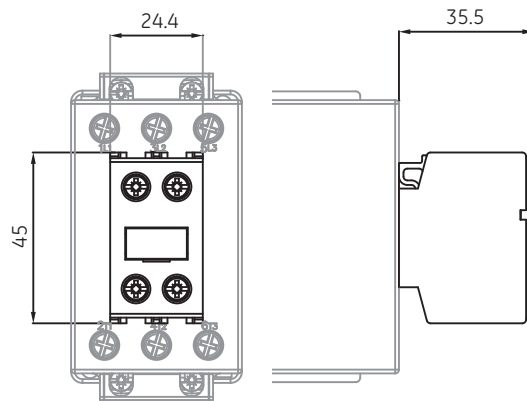

Frontal auxiliary contact block 4P ECFA4S
74 g

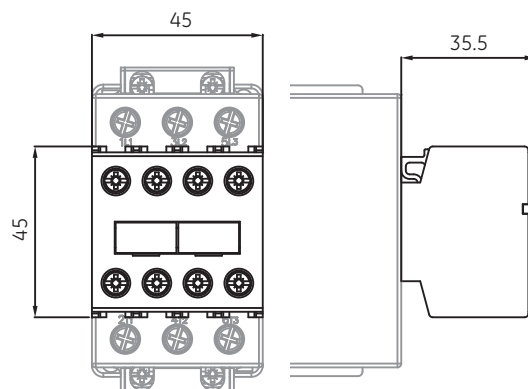

Lateral auxiliary contact block ECLA
70 g

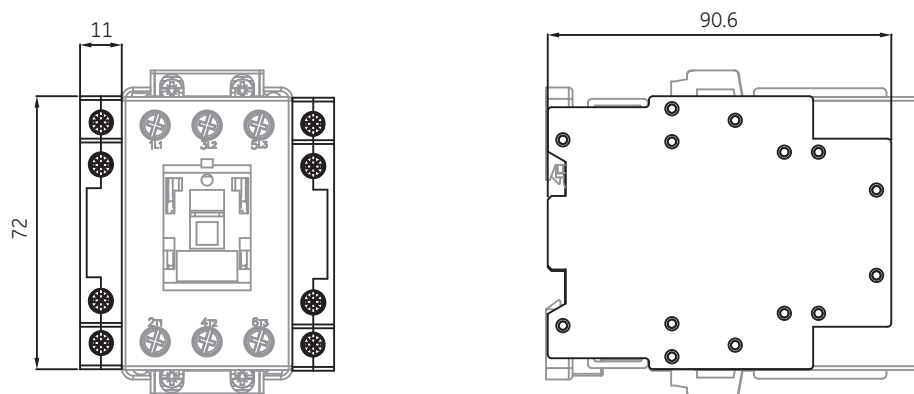

Dimensions in mm (inch = mm x 0.03937) - Weight in kg (lb = kg x 2.2046)

Dimensions and weights

EF contactors

Frontal auxiliary contact block 2P ECFA2S

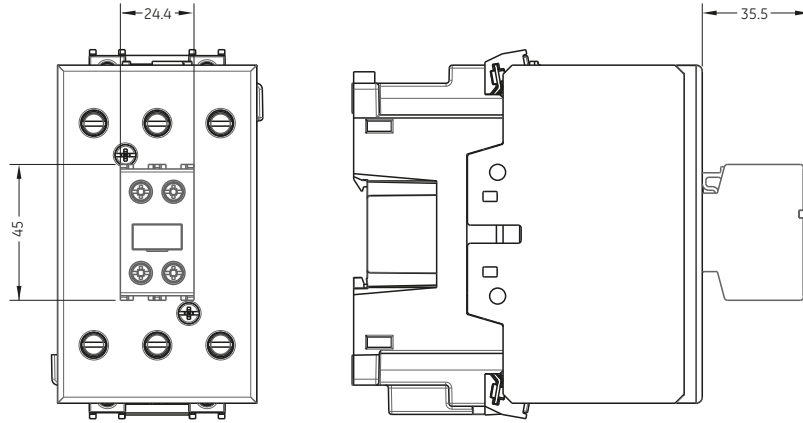

Frontal auxiliary contact block 4P ECFA4S

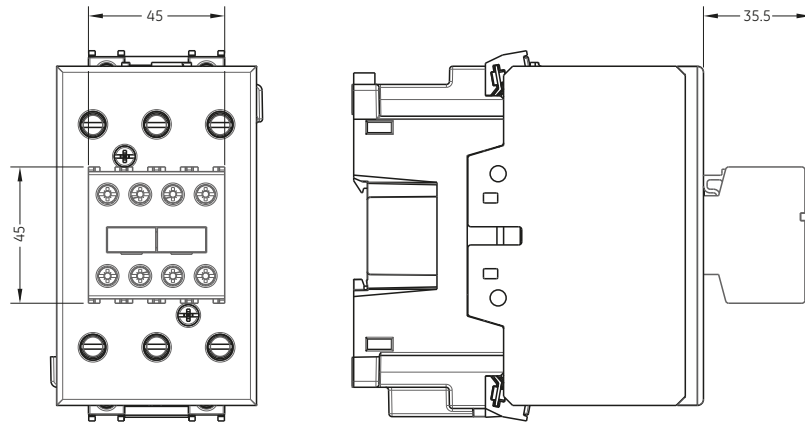

Lateral auxiliary contact block BCLL

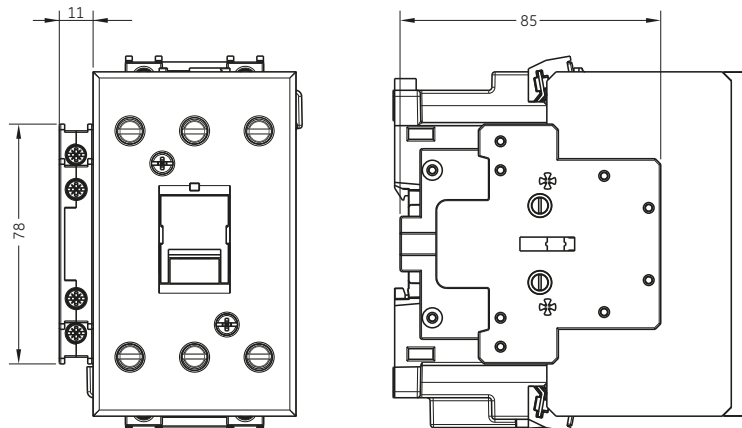

Dimensions in mm (inch = mm x 0.03937) - Weight in kg (lb = kg x 2.2046)

Dimensions and weights

EC contactors

Lateral auxiliary mechanical interlock ECMI
52 g

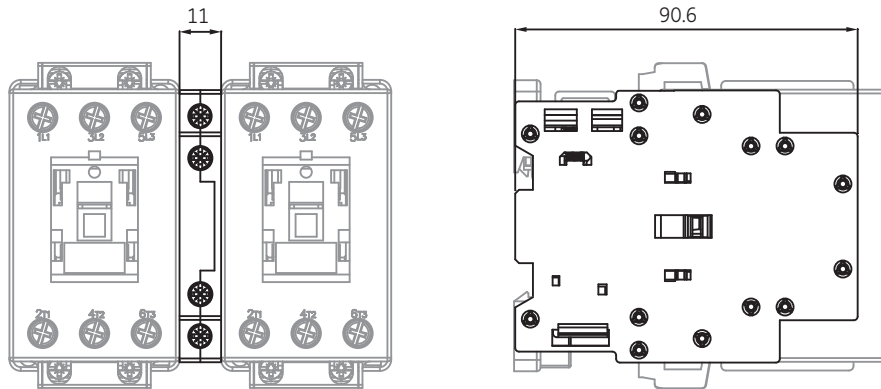

Pneumatic timer ECPT
78 g

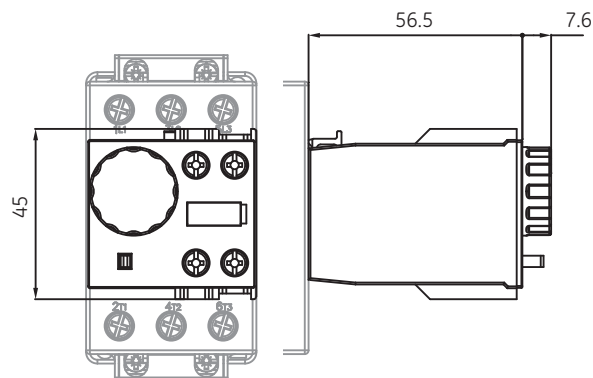

Mechanical latch ECML
113 g

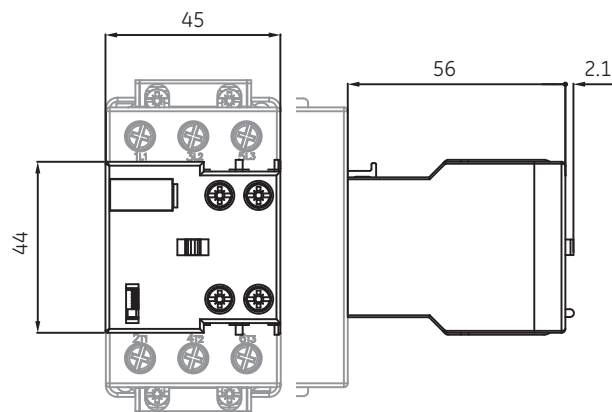

Dimensions in mm (inch = mm x 0.03937) - Weight in kg (lb = kg x 2.2046)

Dimensions and weights

EF contactors

Lateral auxiliary mechanical interlock BELA

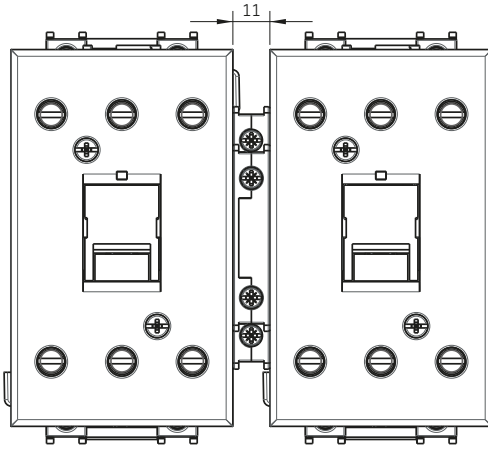

Mechanical latch ECML
113 g

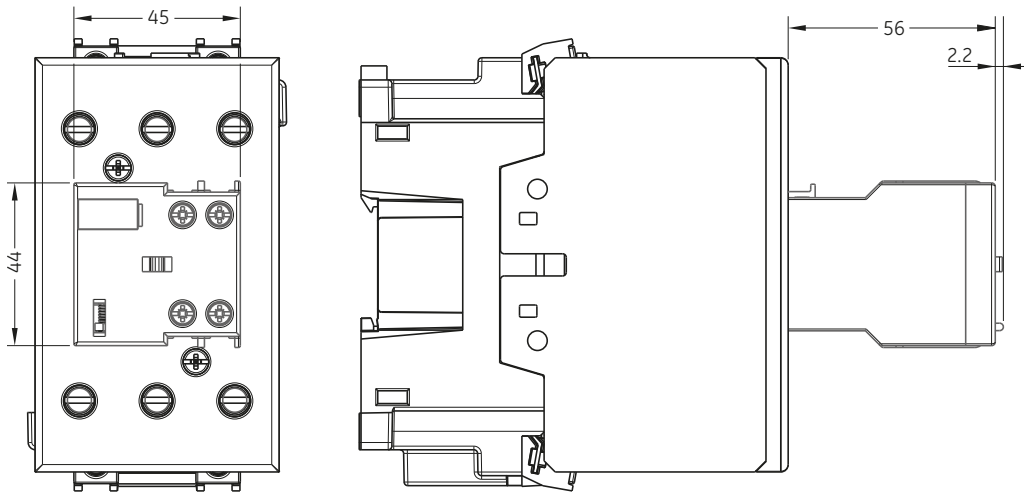

Dimensions in mm (inch = mm x 0.03937) - Weight in kg (lb = kg x 2.2046)



Dimensions and weights

EC contactors

Starter combination of manual motor starter Surion GPS1 and contactor EC09A-12A-18A
787 g

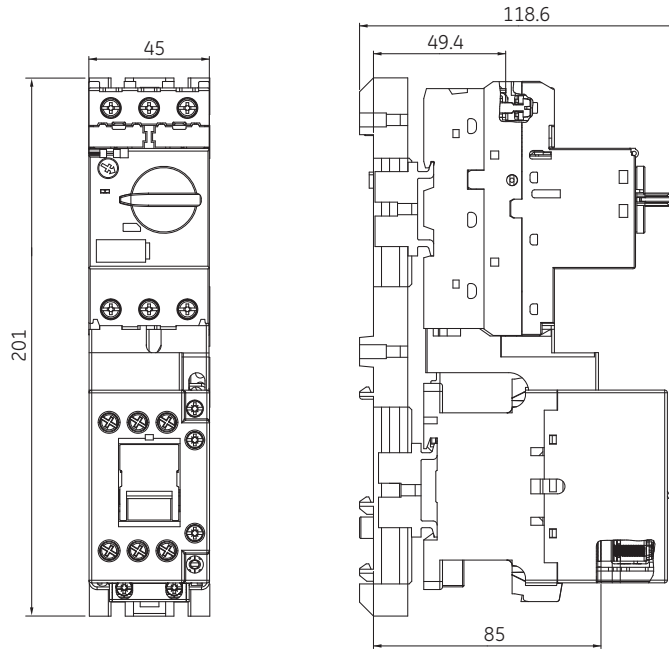

EF contactors

Starter combination of manual motor starter Surion GPS2 and contactor EF50-65-80

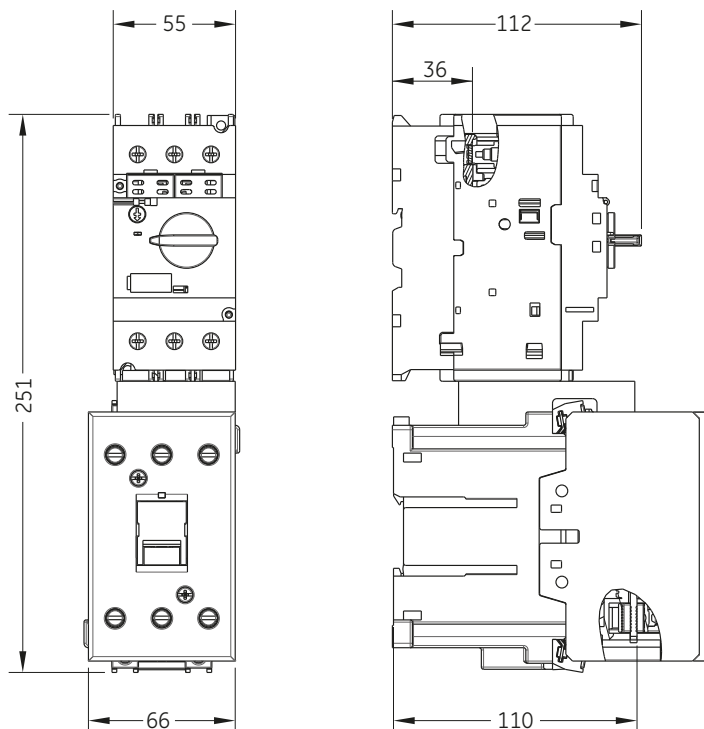

Dimensions in mm (inch = mm x 0.03937) - Weight in kg (lb = kg x 2.2046)

Dimensional drawings

Three and four pole contactors

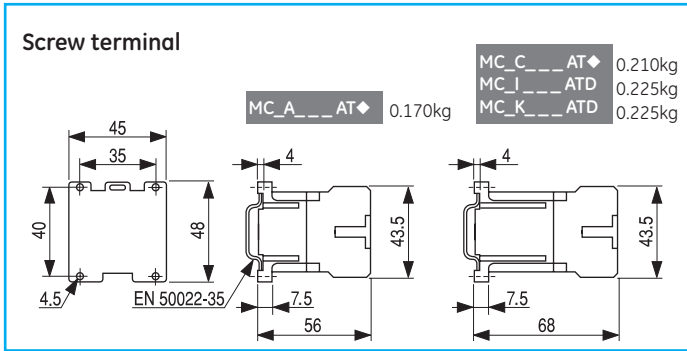

Auxiliary contact block. Front mounting

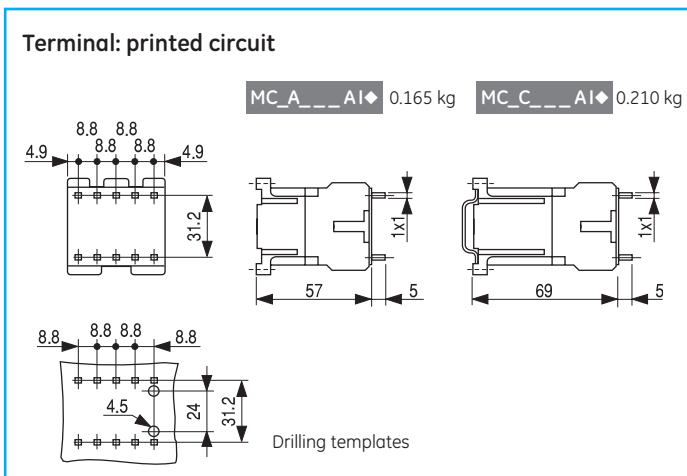
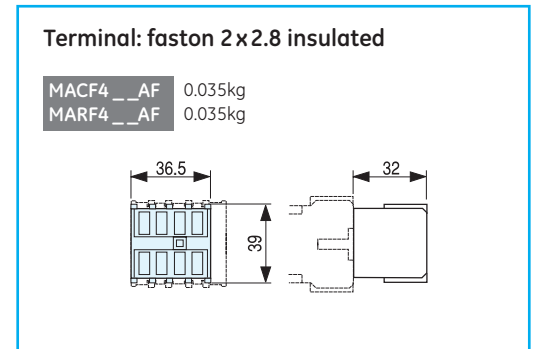
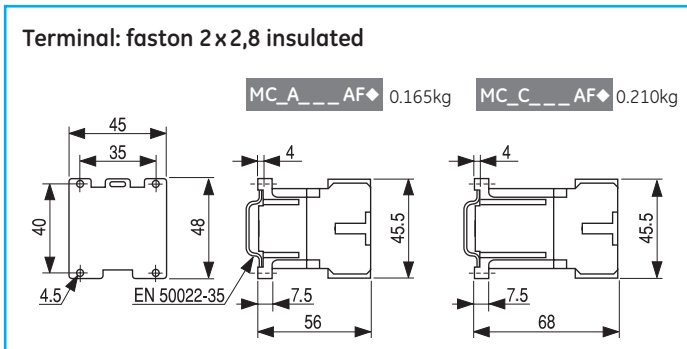
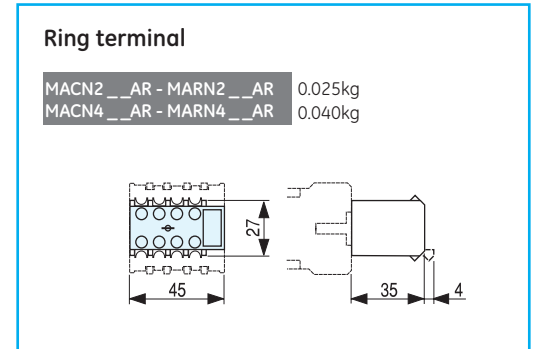
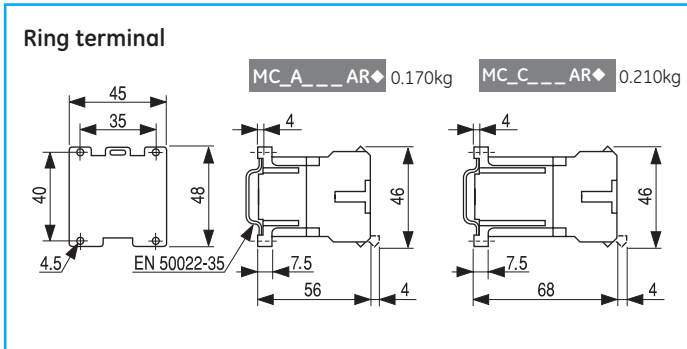
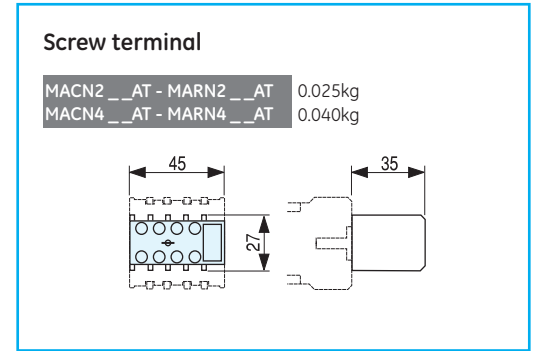

Dimensions in mm (inch = mm x 0.03937) - Weight in kg (lb = kg x 2.2046)



Auxiliary contact blocks. Lateral mounting

Screw terminal

MACL__AT 0.013kg
MARL__ATS 0.013kg

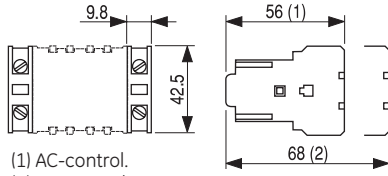

(1) AC-control.
(2) DC-control.

Electronic timer block

MREBC_0AC2 0.040kg

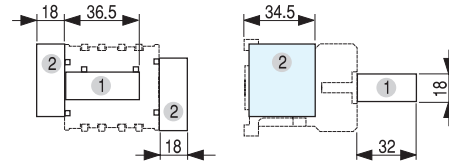

(1) Frontal mounting
(2) Lateral mounting

Ring terminal

MACL__AR 0.013kg
MARL__ARS 0.013kg

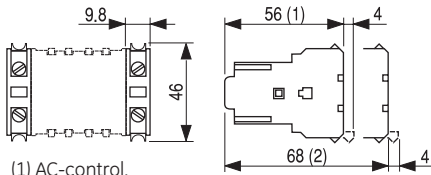

(1) AC-control.
(2) DC-control.

Voltage suppressor block

MPOA_AE 0.010kg
MPOC_AE3 0.010kg

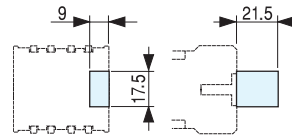

Terminal: faston 2 x 2.8 insulated

MACL__AF 0.009kg
MARL__AFS 0.009kg

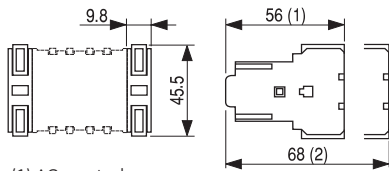

(1) AC-control.
(2) DC-control.

Direct-on-line starters. IP40 / IP65

Series M

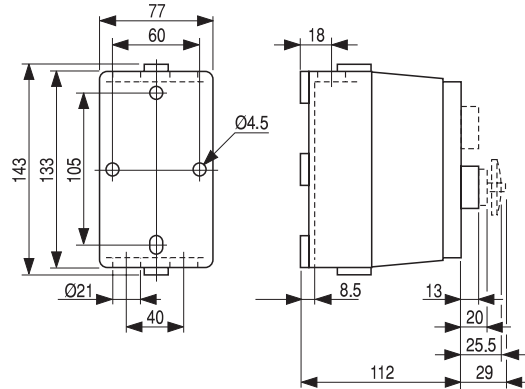

Terminal: printed circuit

MACL__AI 0.009 kg
MARL__AIS 0.009 kg

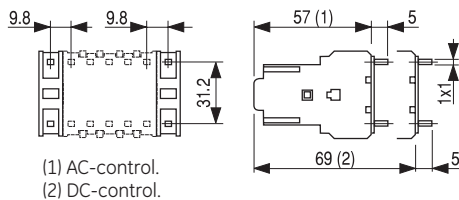

(1) AC-control.
(2) DC-control.

Dimensional drawings

Three pole contactors - Alternating current

CL00A3...., CL01A3...., CL02A3....

0.280 kg 0.280 kg 0.280 kg

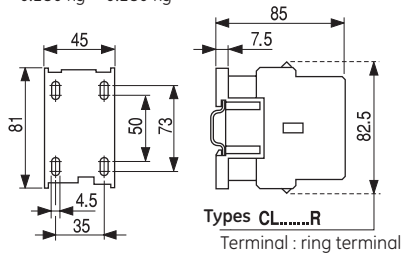

CL03A3...T

0.270 kg

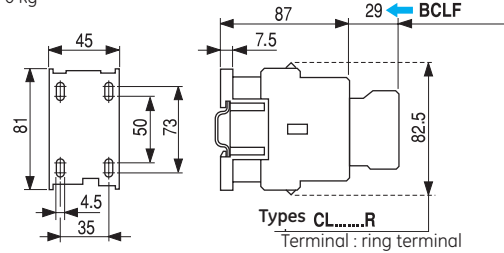

CL04A3....

0.500 kg

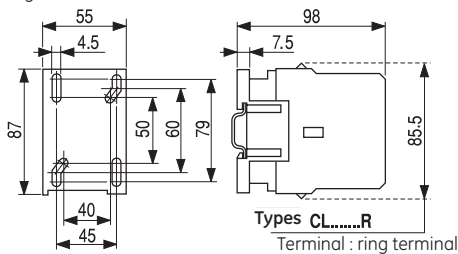

CL05A3....

0.520 kg

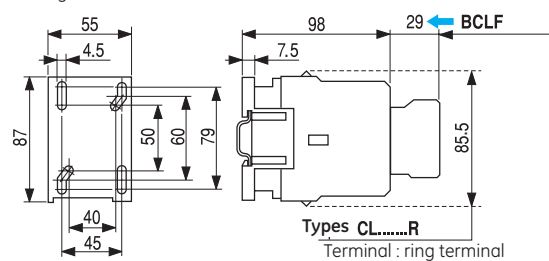

CL06A3...., CL07A3...., CL08A3....

1.105 kg 1.120 kg 1.130 kg

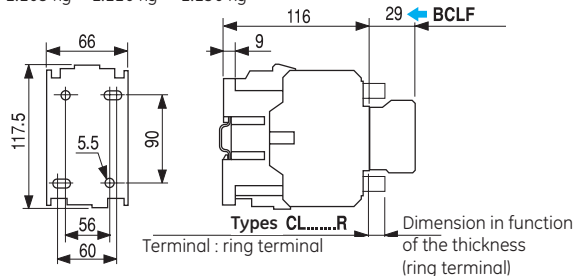

CL09A3...., CL10A3....

1.450 kg 1.470 kg

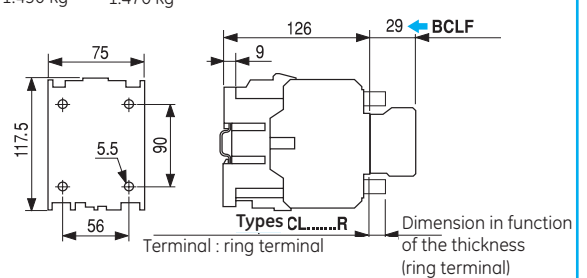

Dimensions in mm (inch = mm x 0.03937) - Weight in kg (lb = kg x 2.2046)



Three pole contactors - Direct current

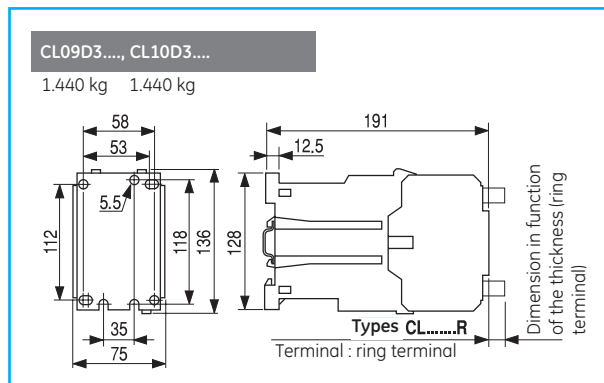
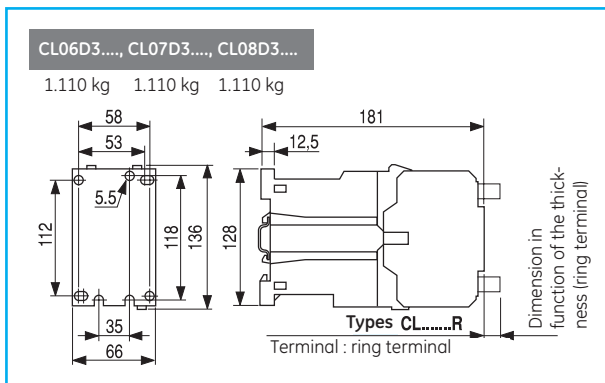
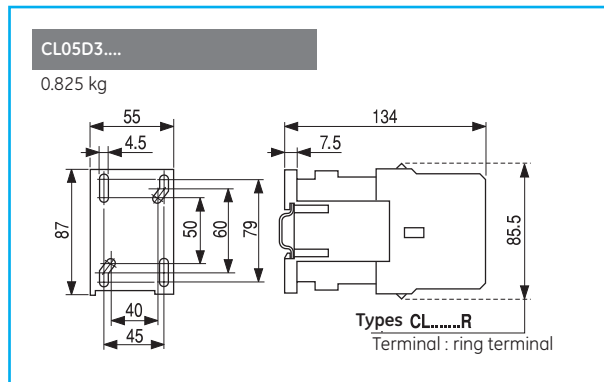
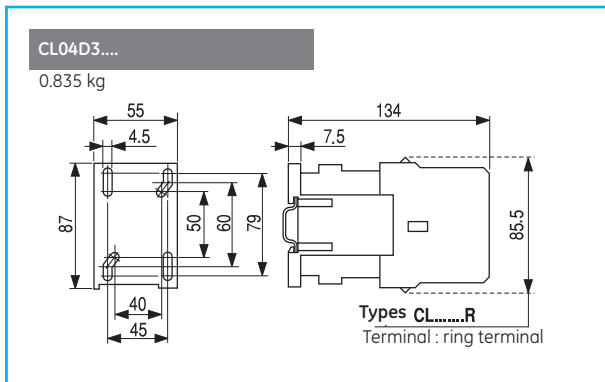
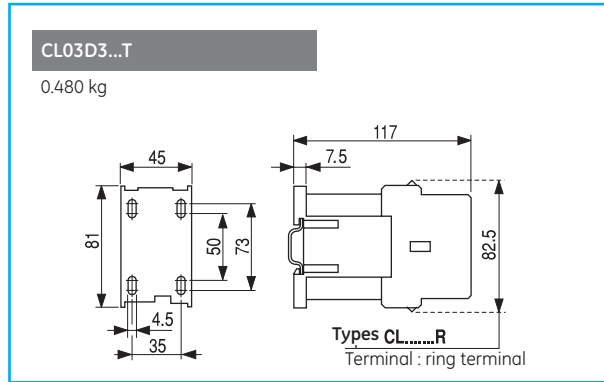
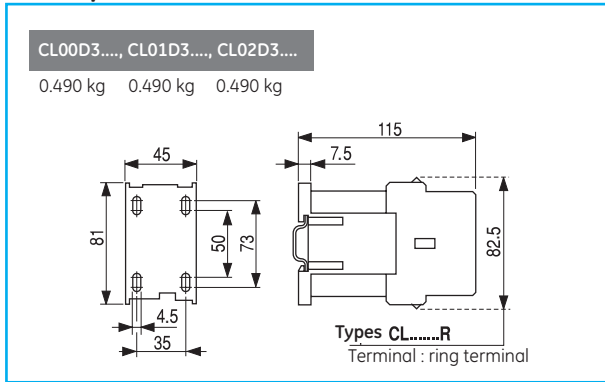

Three pole contactors - Coil with electronic module

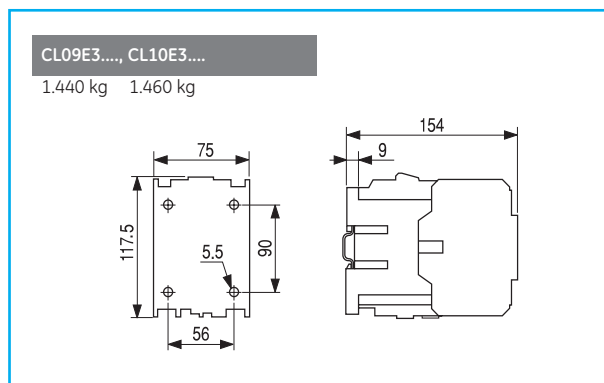
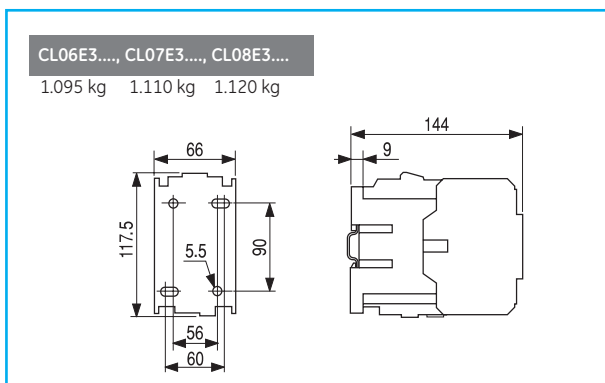

Dimensions in mm (inch = mm x 0.03937) - Weight in kg (lb = kg x 2.2046)



Dimensions

Intro

A

B

C

D

E

F

G

H

I

X

Dimensional drawings

Four pole contactors - Alternating current

CL01A4...., CL02A4...., CL01AB...., CL02AB....

0.280 kg 0.280 kg 0.280 kg 0.280 kg

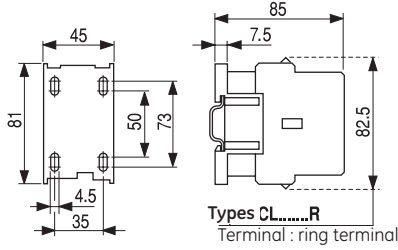

CL03A4...., CL04A4...., CL03AB...., CL04AB....

0.490 kg 0.500 kg 0.490 kg 0.500 kg

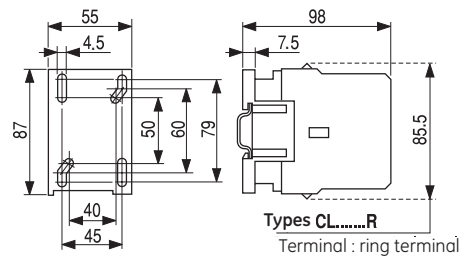

CL05A4...., CL07A4...., CL05AB...., CL07AB...., CL08AB....

1.240 kg 1.270 kg 1.240 kg 1.270 kg 1.270 kg

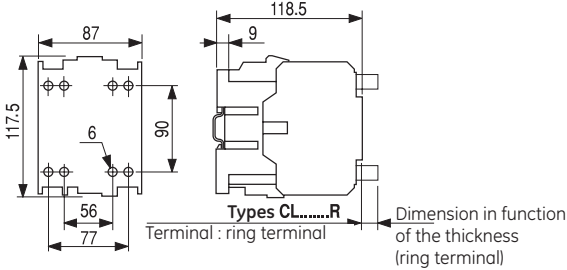

CL09A4....

1.450 kg

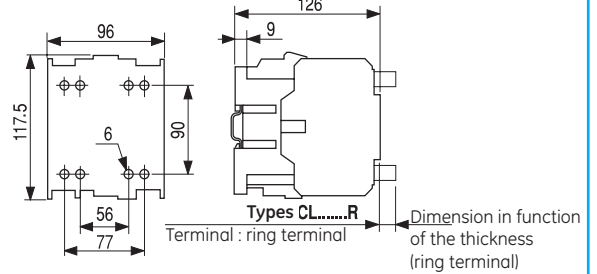

Four pole contactors - Direct current

CL01D4...., CL02D4...., CL01DB...., CL02DB....

0.490 kg 0.490 kg 0.490 kg 0.490 kg

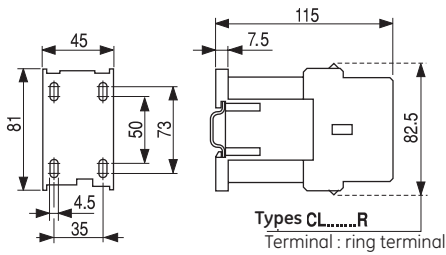

CL03D4...., CL04D4...., CL03DB...., CL04DB....

0.825 kg 0.835 kg 0.825 kg 0.835 kg

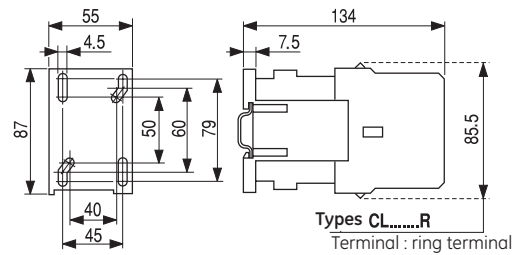

CL05D4...., CL07D4...., CL05DB...., CL07DB...., CL08DB....

1.290 kg 1.290 kg 1.290 kg 1.290 kg

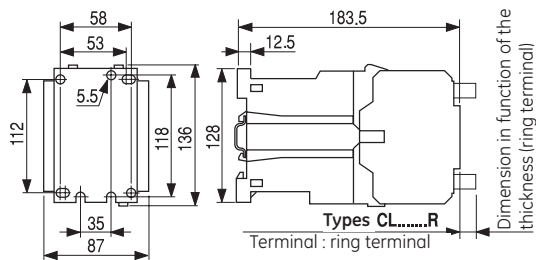

CL09D4....

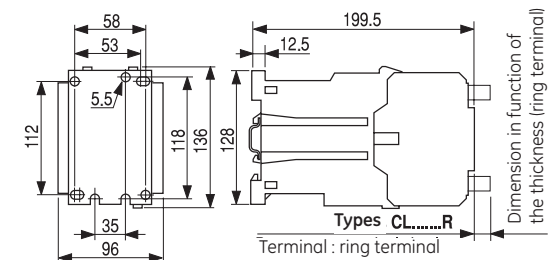

Dimensions in mm (inch = mm x 0.03937) - Weight in kg (lb = kg x 2.2046)



Four pole contactors - Coil with electronic module

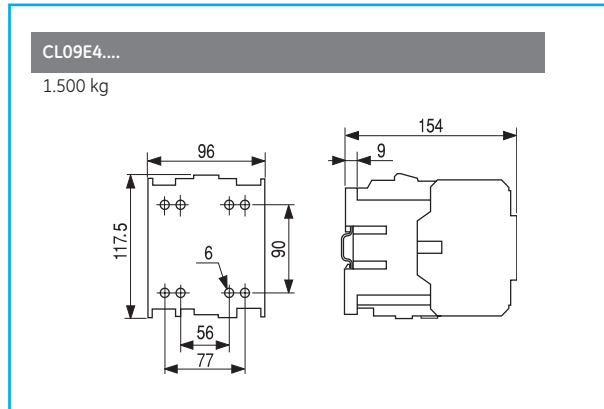
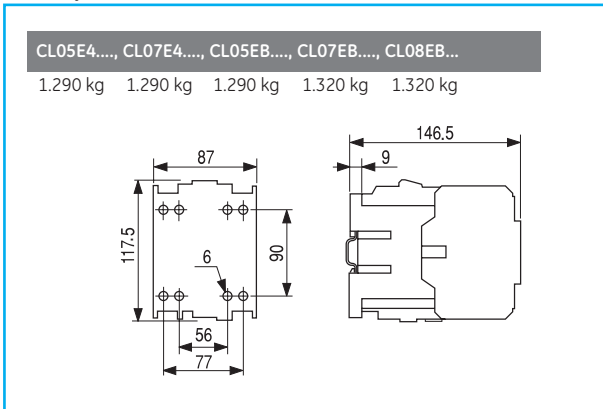

Dimensions in mm (inch = mm x 0.03937) - Weight in kg (lb = kg x 2.2046)



Dimensional drawings

Auxiliary contact blocks

Screw terminal

BCLF... 0.015 kg

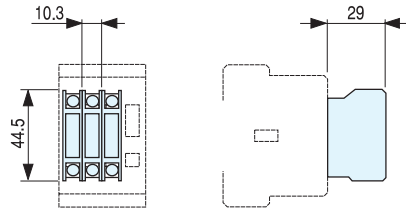

BCLL..., BRLL...

0.048 kg

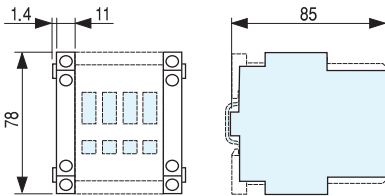

BTLF...

0.085 kg

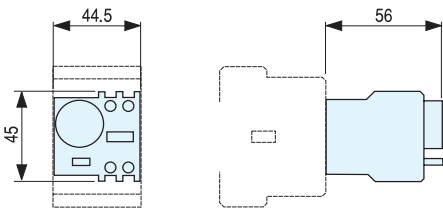

Ring terminal

BCRF... 0.015 kg

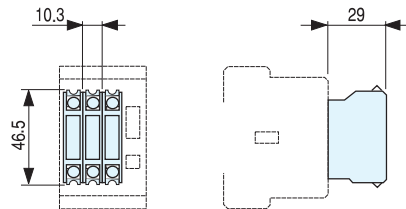

BTRF...

0.085 kg

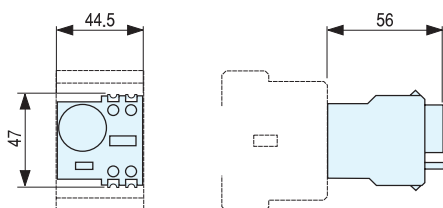

Accessories

Voltage suppressor block

BSLR, BSLDZ, BSLV 0.020 kg

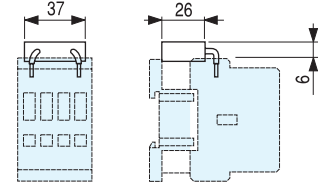

CL00 ... CL03

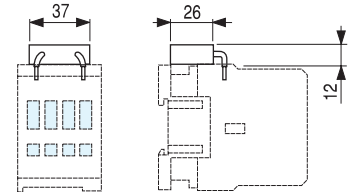

CL04...CL05*3

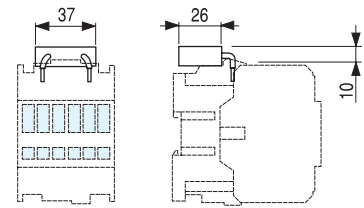

CL05*4... CL10

Mechanical latch block

RMLF 0.082 kg

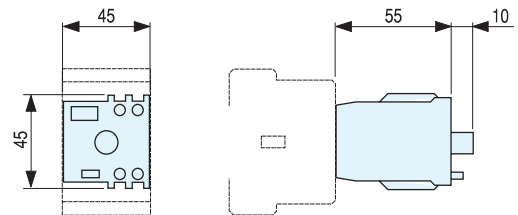

Mechanical / mechanical-electrical interlock

BEL, BELA, BEL02, BELA02 0.025 kg

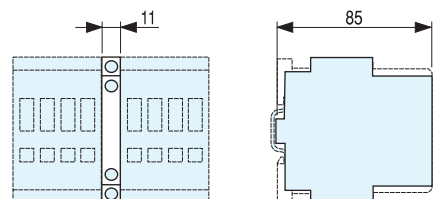

Dimensions in mm (inch = mm x 0.03937) - Weight in kg (lb = kg x 2.2046)



Electronic timer block

BETL02, BETL45 0,040 kg

CL00 ... CL03

CL04...CL05*3

CL05*4... CL10

Direct-on-line starters. IP40 / IP65

Series CL

	LG00... - LG02...	LG25... - LG04...
A	87	101
B	180	195
C	124.5	136
D	162	177
E	20	23
F	49	57
G	8	8
Ø H	21	23
Ø J	21	21
Ø K	21	23
Ø L	21	23

Dimensions in mm (inch = mm x 0.03937) - Weight in kg (lb = kg x 2.2046)

Four pole contactors

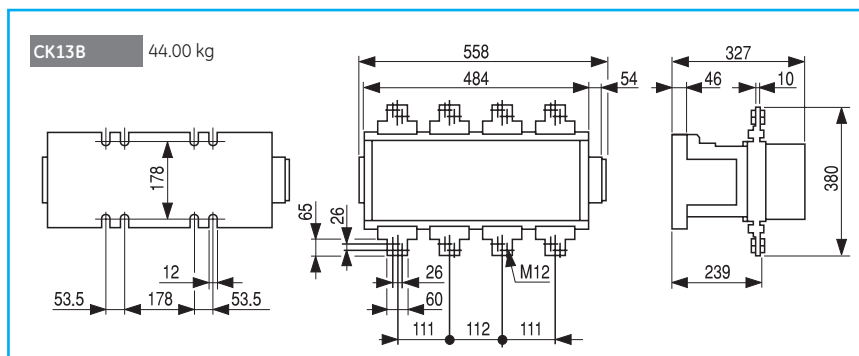
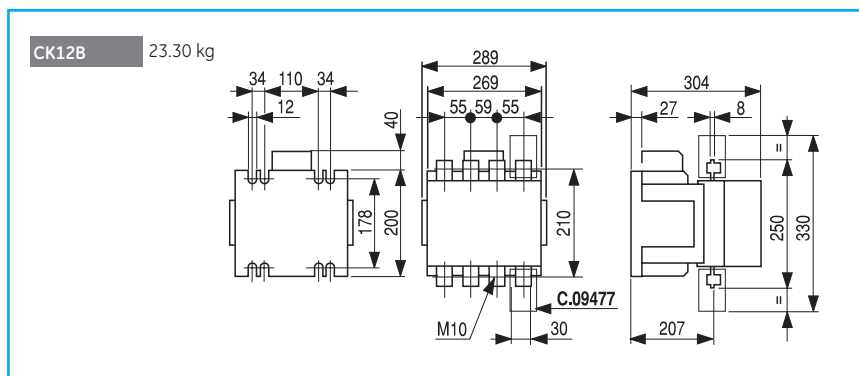
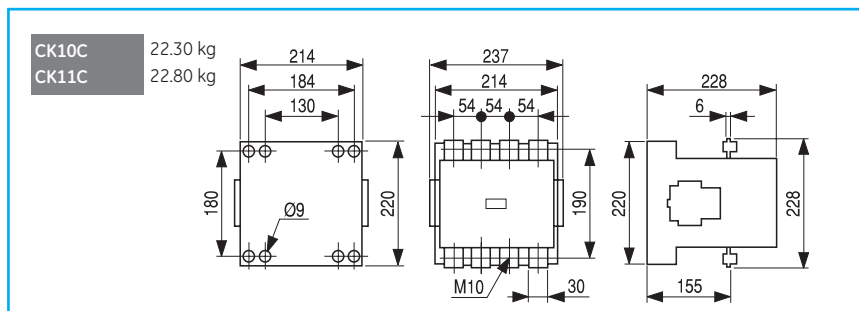
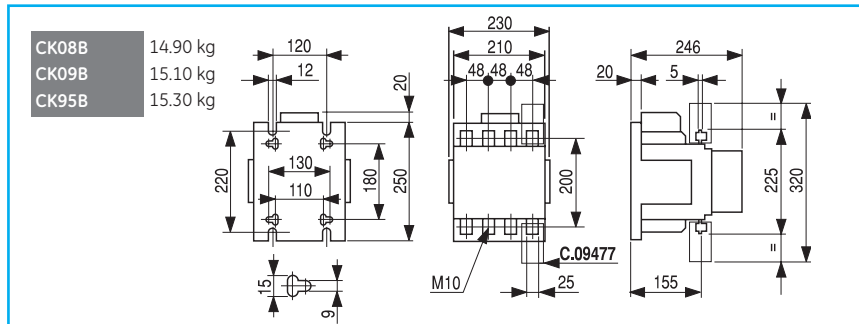
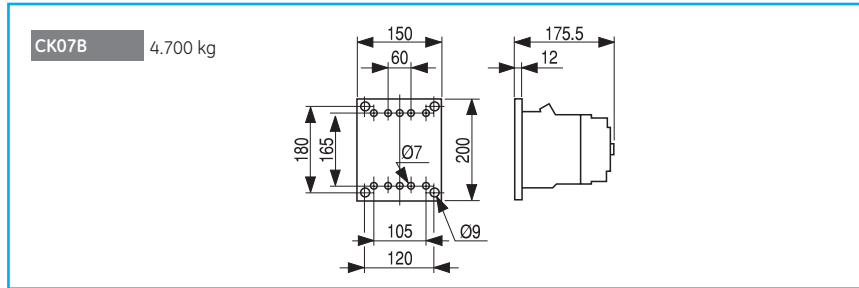

Dimensions in mm (inch = mm x 0.03937) - Weight in kg (lb = kg x 2.2046)

Mechanical interlock

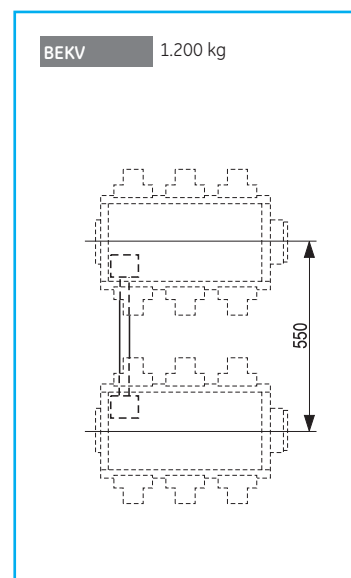
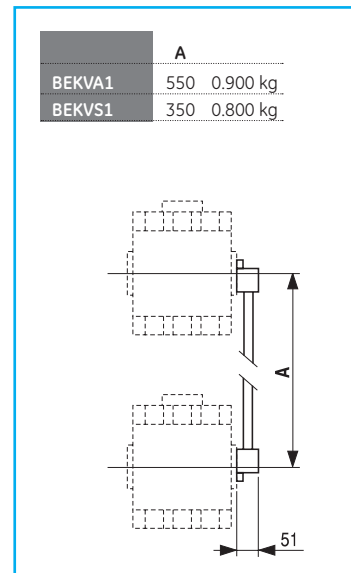
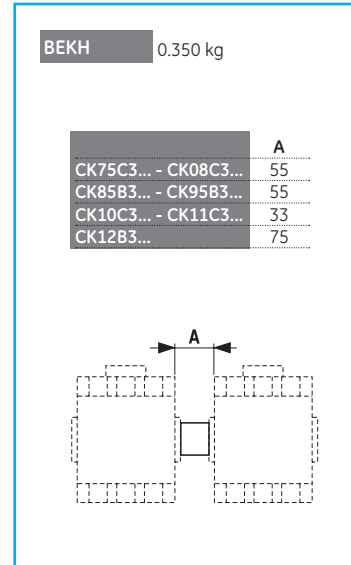

Overload relays

- Control and Power Circuit up to 690V AC
- Thermal protection against balanced overload
- Three-pole differential (phase unbalance protection)
- Automatic ambient temperature compensation
- Front mounted selector for choosing utilization current
- Manual trip lever (tripping test)
- Tripping indicator (0-1)
- IP20 protection
- Reset button, 4 positions:
 - Manual RESET
 - Manual RESET and STOP
 - Automatic RESET with STOP
 - Automatic RESET without STOP

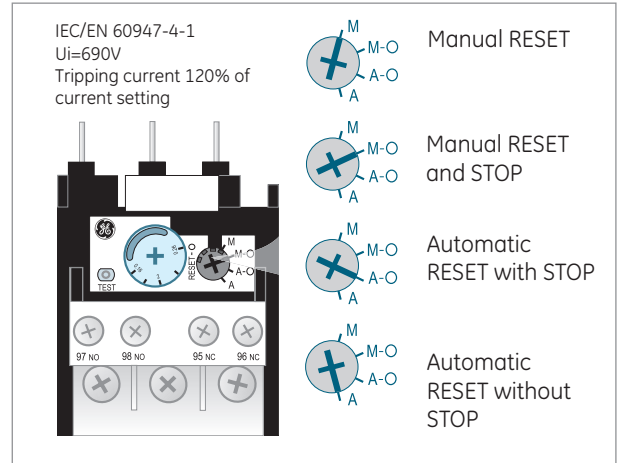

Technical characteristics

		ECRT	RT2	RE
Class		10A	10	5, 10, 20 and 30
Setting range	(A)	0.16..40	11.5..110	0.1..110
Main circuit				
Rated insulation voltage	(V)	690	690	690
Frequency limits	(Hz)	0-400	0-400	0-400
Control circuit				
Rated insulation voltage (IEC60947-4) Ui	(V)	690	690	690
Rated thermal current Ith	(A)	10	10	10
Operating current				
AC-15 - rated voltage and current Ue-Ie	(V-A)	110/120-3	220/230-2 380/400-1 480/500-0.8	690/660-0.3
DC-13 - rated voltage and current Ue-Ie	(V-A)	24-2	48-1.4 110-0.6 220-0.3	440-0.1
Utilization according UL and CSA		B600-Q600		
Protective fuse type gL	(A)	10		
Terminal capacity	AWG	2.5		
Tightening capacity	(Nm)	0.8		

Ambient conditions for ECRT, RT2 and RE

Storage temperature	-55°C to +80°C
Operation temperature (compensated)	-25°C to +60°C
Altitude <2000 m	without any changes in characteristics
Relative humidity	40°C, 95% no cond.
Protection treatment	Lloyd's Register Environmental category ENV1 & ENV2 10:33 Germanischer Lloyd Environmental category C

Remote electrical reset

Power consumption	
AC	100VA
DC	100W

Coils not suitable for continuous operating duty

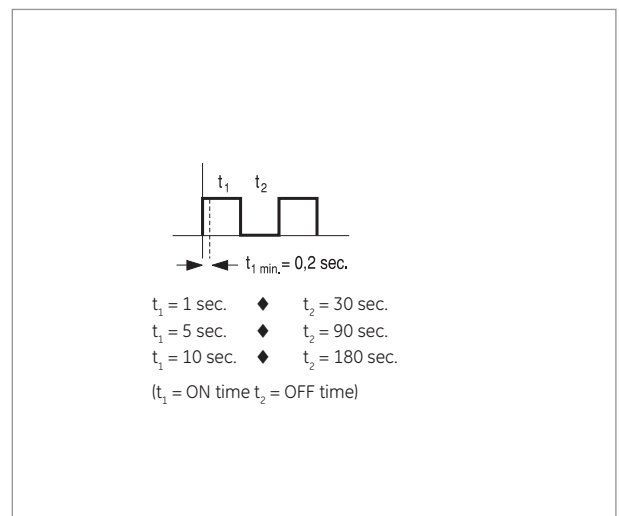

Mounting positions

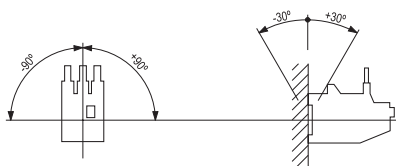

Inclination angle axis Y and Z: $\pm 30^\circ$

Tripping curves

ECRT Class 10A

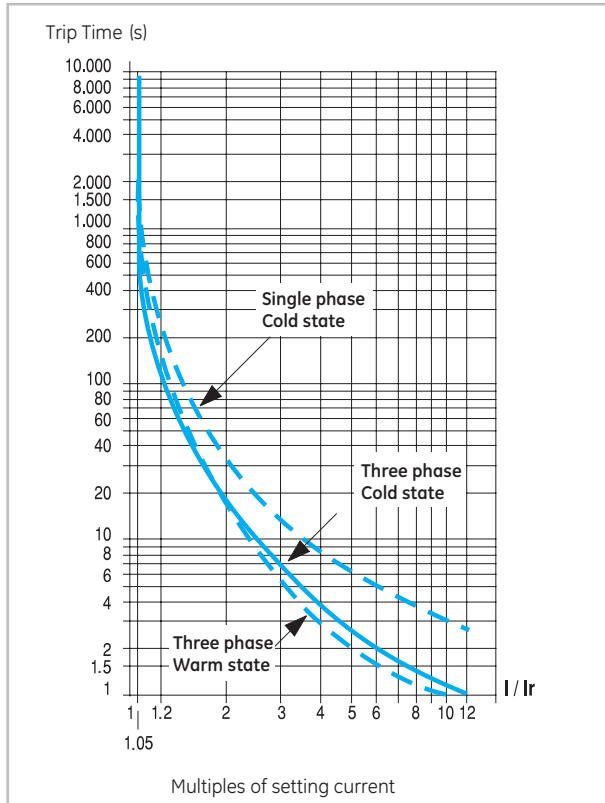

RT2 Class 10

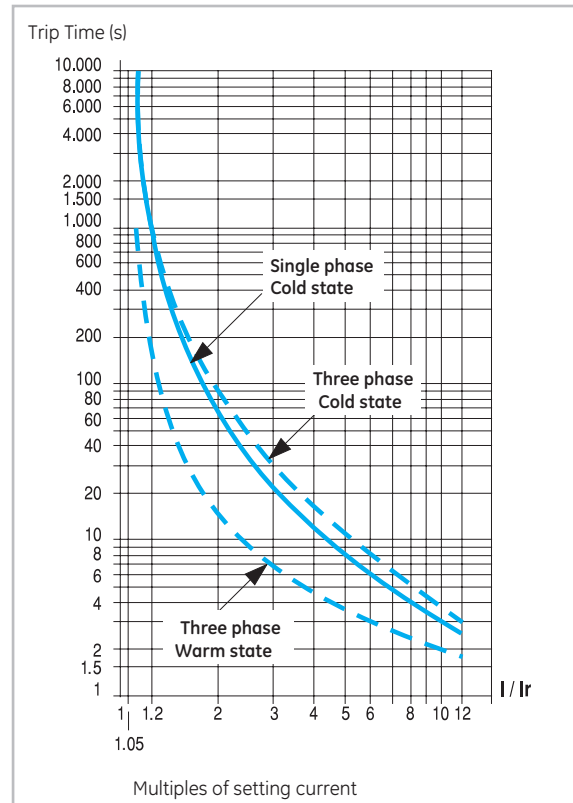

RE Class 5, 10, 20 and 30

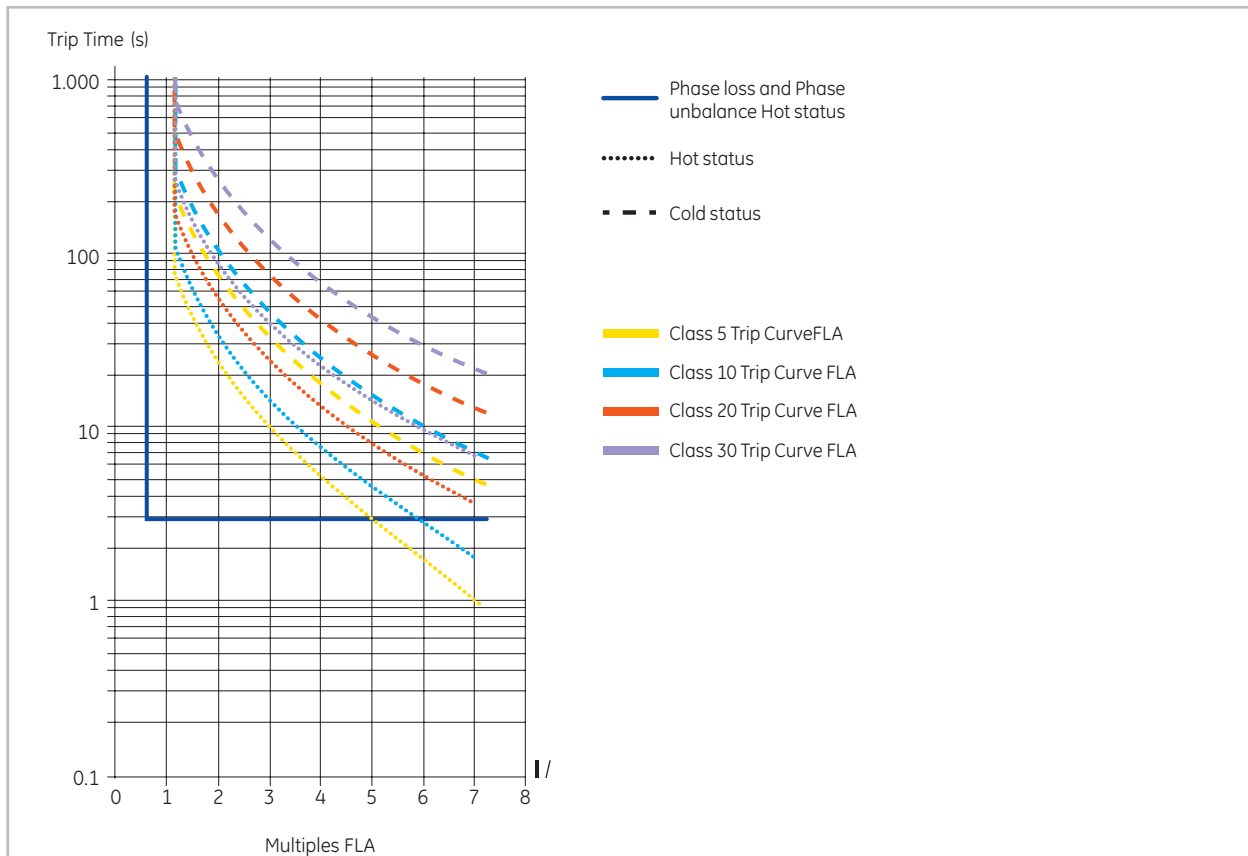

Technical data

General

- Thermal protection against balanced overload.
- Three-pole differential (phase unbalance protection).
- Automatic ambient temperature compensation.
- Front mounted selector for choosing utilisation current.
- Reset button, 2 positions:
Manual(H) and Automatic(A) by turning the blue selector.
- Stop push button, independent of reset (red).
- Manual trip lever (tripping test).
- Tripping indicator (0-1).
- To facilitate wiring arrangements terminal 96 fits directly onto coil terminal (A2) and terminal 14/22 fits directly onto the feedback auxiliary contact.

Conformity to standards

IEC 60947-4	CEI 17-50	VDE660
UNE 115	NI C63-650	UL508
NFC63-650		

Approvals

UL	CSA	SEMKO
SETI	NEMKO	CE

Ambient conditions

Storage temperature	-55°C to +80°C	
Operation temperature	-25°C to +60°C	
Altitude	up to 3000m	
	from 3000 to 4000m	90%le 80%Ue
	from 4000 to 5000m	80%le 75%Ue
Degree of protection	IP20	
Protection treatment	Tropical finish	

Climatic resistance

Continuous tests 40 / 125 / 56		
Cold (72h)	Temperature	-40°C
	Dry heat (96h)	Temperature
Humid heat (56 days)	Relative humidity	< 50%
	Temperature	+40°C
Cyclical tests	Relative humidity	95%
	First half-cycle (12h)	Low temperature
Relative humidity		93%
Second half-cycle (12h)	Low temperature	+55°C
	Relative humidity	95%
Number of consecutive cycles		6

Mounting positions

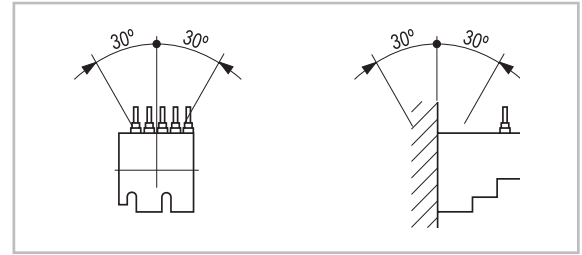

Main circuit (poles)

		MT0...
Rated insulation voltage (Ui) according to IEC 947	(V)	750
Frequency	(Hz)	0...400
Power dissipation per pole	(W)	min. 1 / max. 2.5
Terminal capacity		
Screw M 3.5 (pozidrive head) safety flange		
Maximum capacity:		
Solid	(Ø mm)	2 x 2 wires
Stranded without end sleeve	(mm²)	2 wires Ø 2.5
Stranded with end sleeve		
pen (2 end sleeves)	(mm²)	2 wires Ø 0.75
pen (1 end sleeve)	(mm²)	2 wires Ø 1
		1 wires Ø 2.5
Tightening torque	(Nm)	0.8

Control circuit (incorporated auxiliary contact)

		MT0...
Rated insulation voltage (Ui) according to IEC 947	(V)	750
Rated thermal current (Ith) $\theta \leq 60^\circ\text{C}$	(A)	10
Tripping currents		
AC-15	Ue-Ie (V-A)	223-3, 380-2, 500-1
DC-13	Ue-Ie (V-A)	60-0.5, 110-0.2, 220-0.1
Short-circuit protection (max.glass gL fuse - w/h welding)	(A)	6
Number and type of contacts		

Control circuit (auxiliary contact block)

		MATV10AT
Rated insulation voltage (Ui) according to IEC 947	(V)	750
Rated thermal current (Ith) $\theta \leq 60^\circ\text{C}$	(A)	10
Tripping currents		
AC-15	Ue-Ie (V-A)	223-1, 380-0.5
DC-13	Ue-Ie (V-A)	60-0.1, 110-0.5
Short-circuit protection (max.glass gL fuse - w/h welding)	(A)	6
Number and type of contacts		

Numbering of the terminals

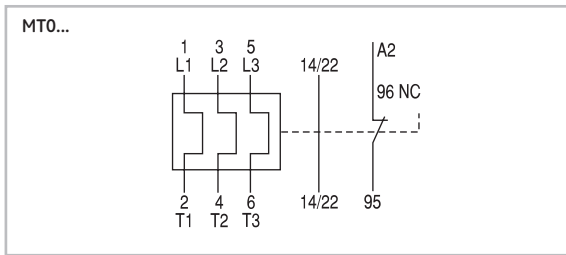

Tripping curves

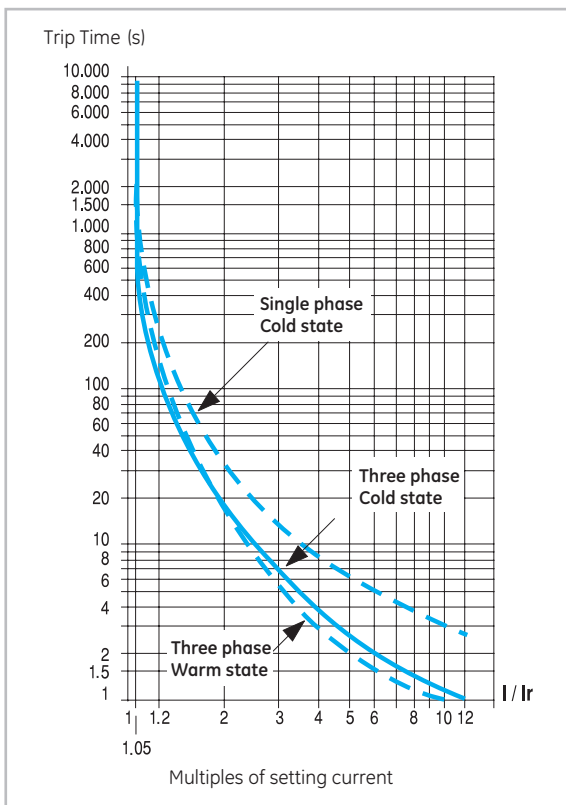

Dimensional drawings

Thermal overload relay

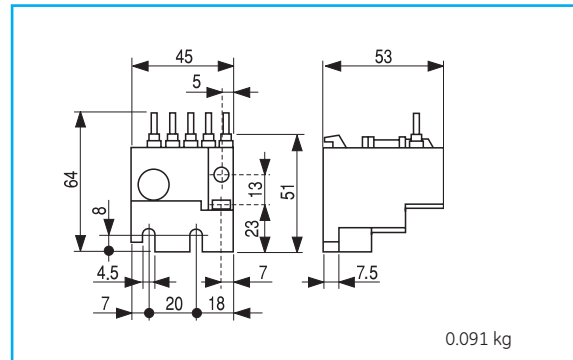

Thermal overload relay + aux. contact block (front mounting)

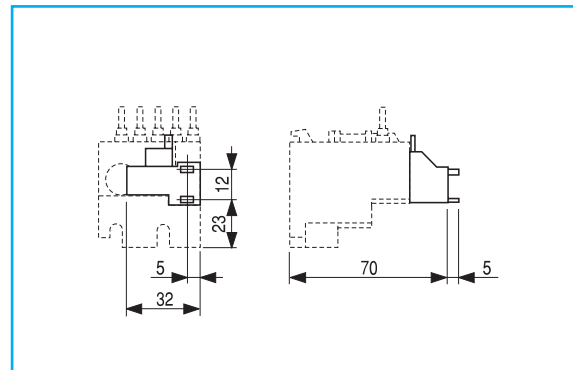

Independent mounting of the thermal overload relay

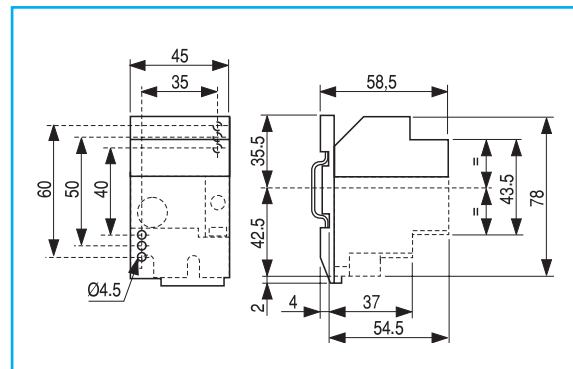

Technical data

		RT1...	RT2...	RT3...	RT4.../ 4L...	RT5.../ 5L...	RT6.../ 6L...
General							
Class		10A / 20	10 / 20	10 / 20	10 / 30	10 / 30	10 / 30
Setting range	(A)	0.16 ... 40	11.5 ... 110	55 ... 190	2.5 ... 310	120 ... 700	500 ... 850
Suitable for		CL00..CL05	CL06..CL10	CK75..CK08	CL,CK	CK10..CK12	CK13
Main circuit							
Rated insulation voltage	(V)	690	1000	1000	1000	1000	1000
(IEC947-4) Ui							
Frequency limits	(Hz)	0..400	0..400	0..400	50..60	50..60	50..60
Terminal capacity							
Clamp terminal - solid	(mm ²)	16	50	120	-	-	-
Clamp terminal - flexible	(mm ²)	10	50	120	-	-	-
Flat terminal	(mm)	-	-	25 x 5	-	-	80 x 10
Passing by hole (wire) through C.T. core	(mm ²)	-	-	-	-	400	-
Passing by hole (bar) through C.T. core	(mm)	-	-	-	30 x 10	30 x 10	-
Tightening torque	(Nm)	2.5	4.5	6.5	23	31.5	-
Control circuit							
Rated insulation voltage	(V)	690					
(IEC60947-4) Ui							
Rated thermal current I _{th}	(A)	10					
Operation current							
AC-15 - U _e -I _e	(V - A)	110/120 - 3 ; 220/240 - 2 ; 380/415 - 1 ; 480/500 - 0.8 ; 660/690 - 0.3					
DC-13 - U _e -I _e	(V - A)	24 - 2 ; 48 - 1.4 ; 110 - 0.6 ; 250 - 0.3 ; 440 - 0.1					
Utilisation according UL and CSA		B600 - Q600					
Protective fuse type gL	(A)	10					
Terminal capacity	(mm ²)	2.5					
Tightening capacity	(Nm)	0.8					

Conformity to standards

IEC/EN 60947-4-1	NFC 63-650	NI C 63-650
IEC/EN 60947-5-1	CEI 17-50	VDE 0660
UNE 115	CSA 22.2/14	UL 508

Remote electrical reset

Power consumption		
AC	(VA)	100
DC	(W)	100

Coils not suitable for continuous operating duty

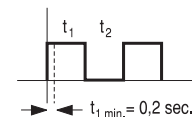

t ₁ = 1 sec.	◆	t ₂ = 30 sec.
t ₁ = 5 sec.	◆	t ₂ = 90 sec.
t ₁ = 10 sec.	◆	t ₂ = 180 sec.

(t₁ = ON time t₂ = OFF time)

Approvals/Marking

cULus	RINA	CE
Lloyd's Register	Bureau Veritas	

Ambient conditions

Storage temperature	-40°C to +70°C	
Operation temperature (compensated)	-25°C to +60°C	
Altitude	up to 3000m	w/o any changes in characteristics
Relative humidity	98%	
Protection treatment	Tropical finish	

Mounting positions

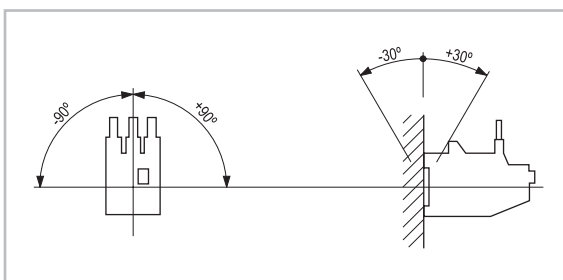

Tripping curves

RT1 Class 10A

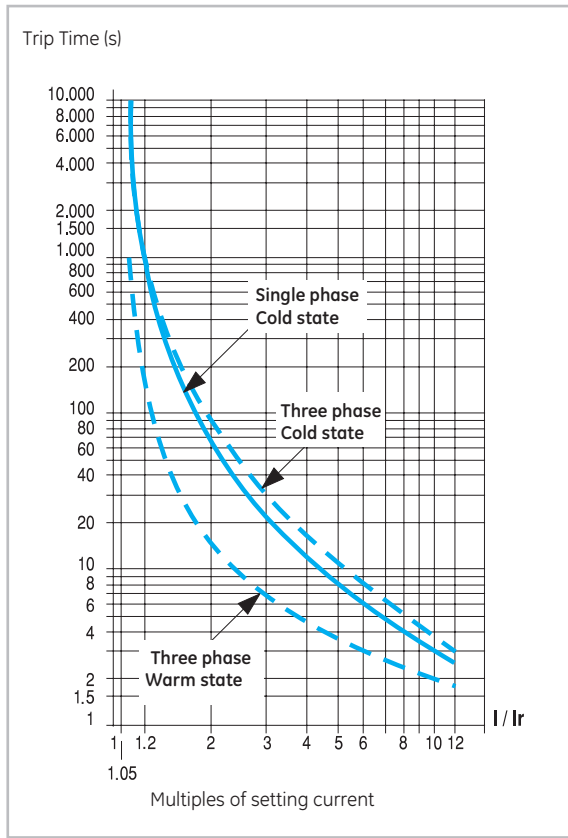

RT2 Class 10

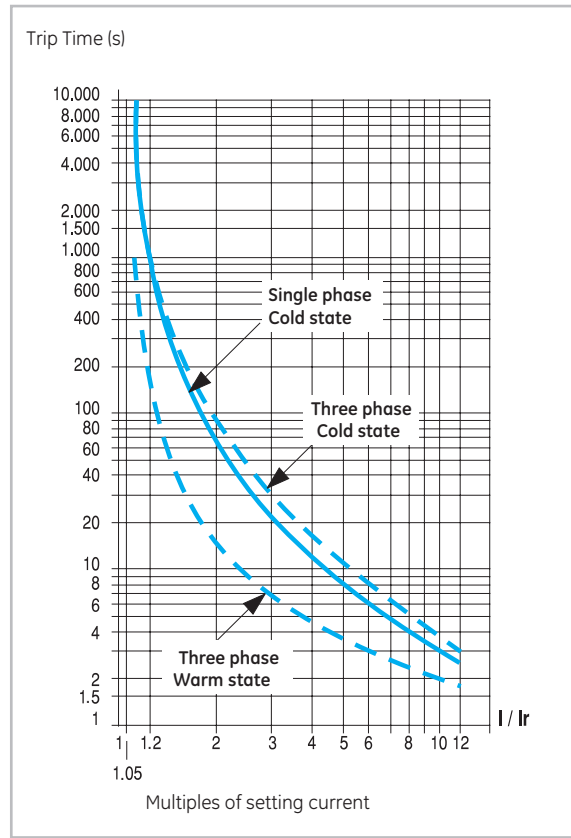

RT12 Class 20

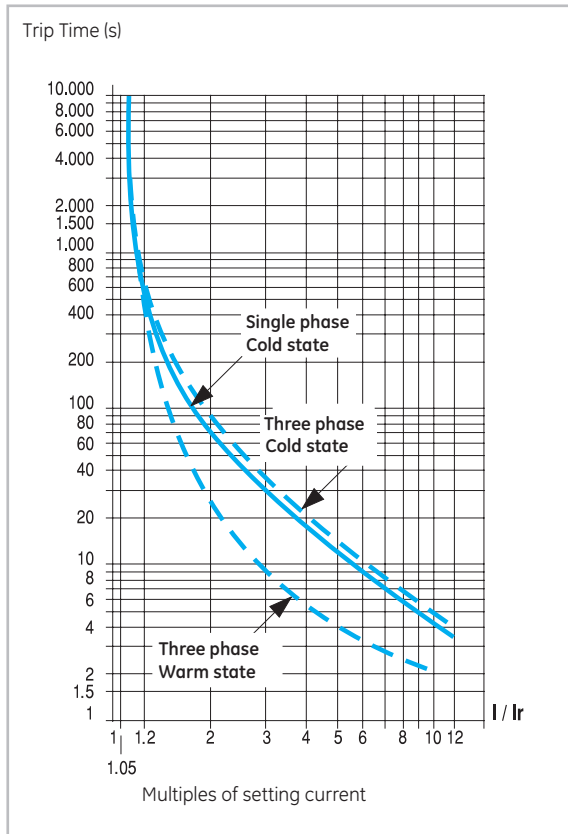

RT22 Class 20

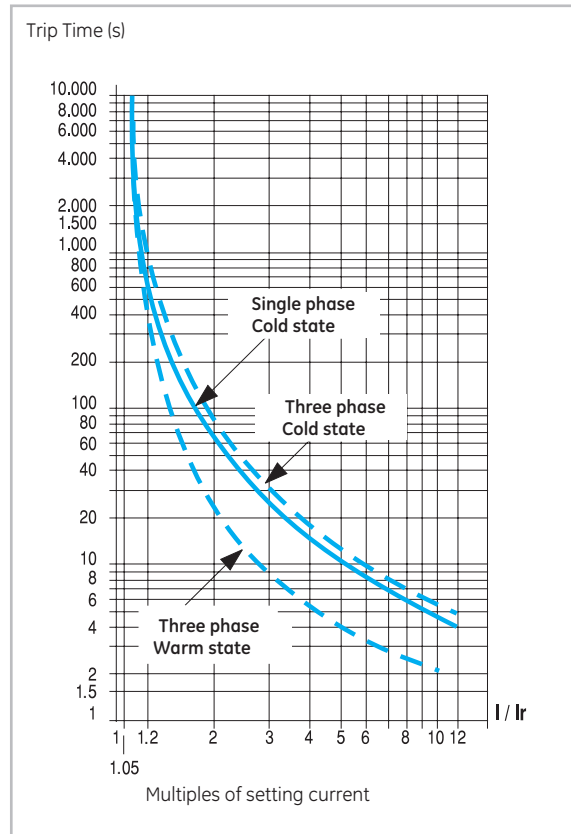

Series RT

Tripping curves

RT3 Class 10

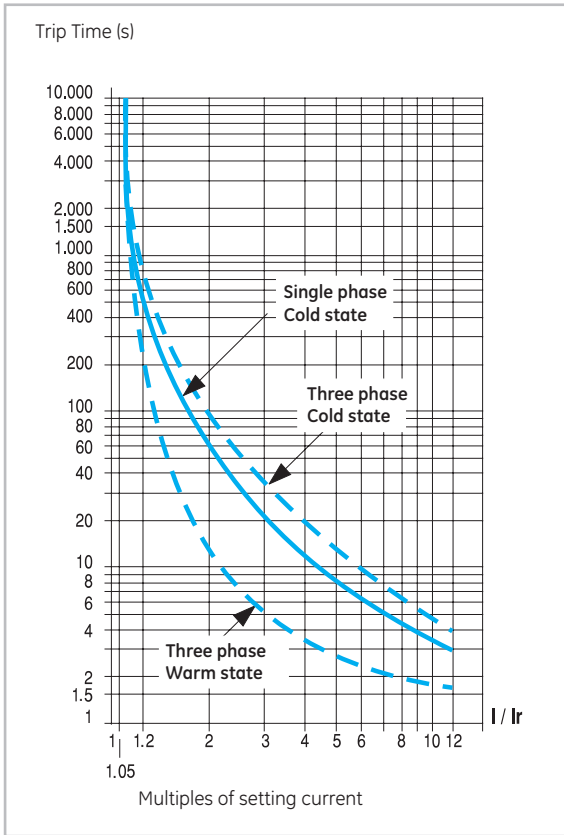

RT4 Class 10

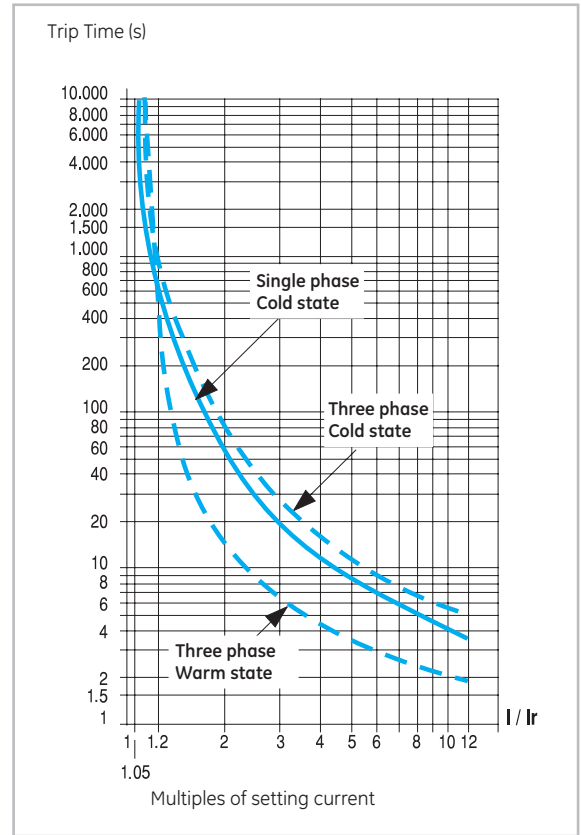

RT32 Class 20

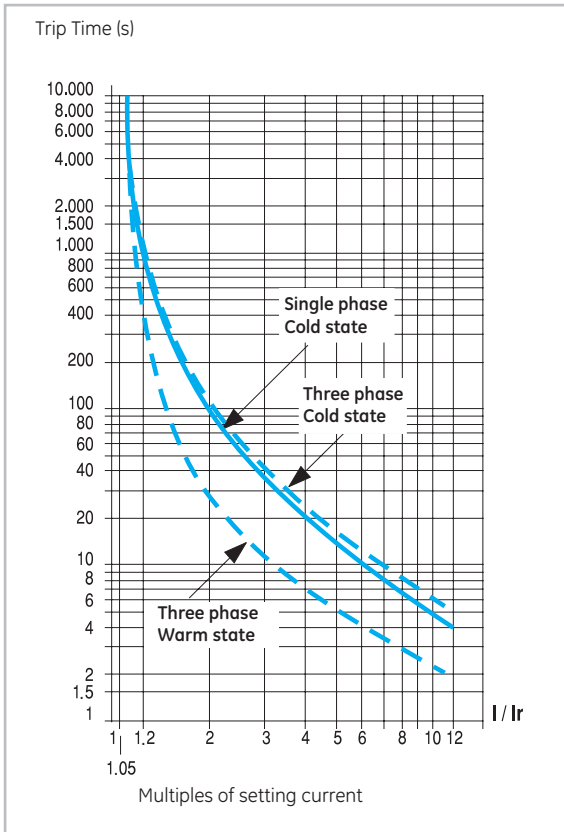

RT4L Class 30

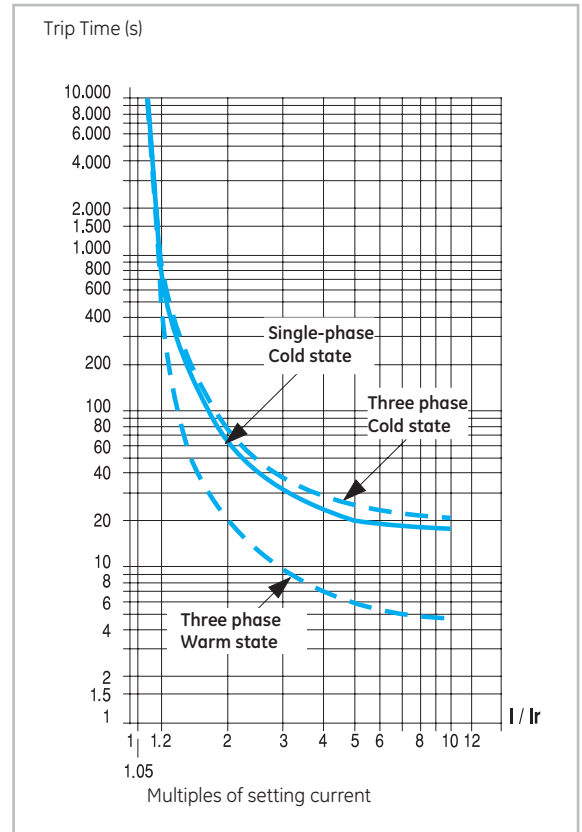

Tripping curves

RT5 Class 10

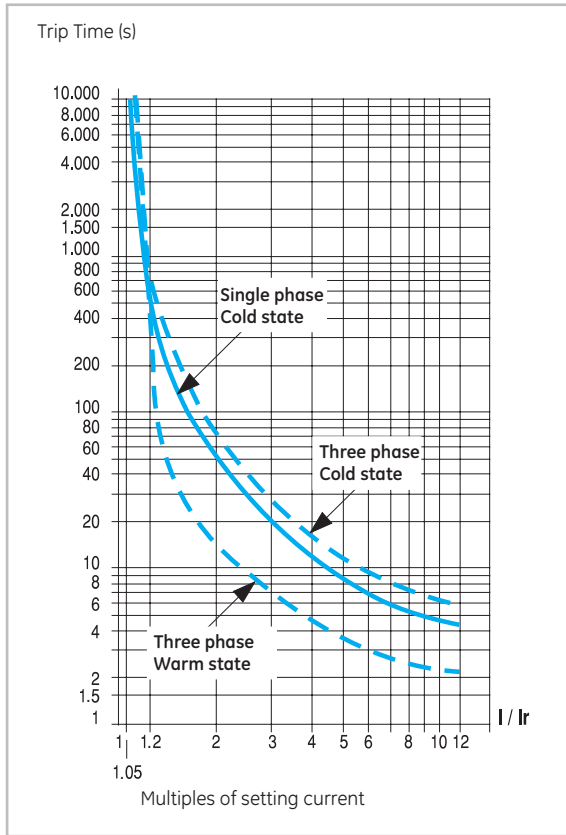

RT6 Class 10

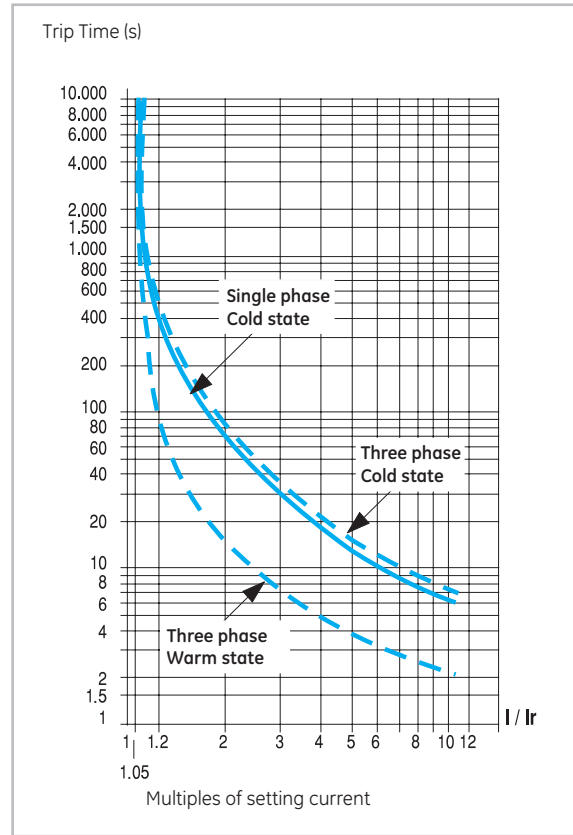

RT5L Class 30

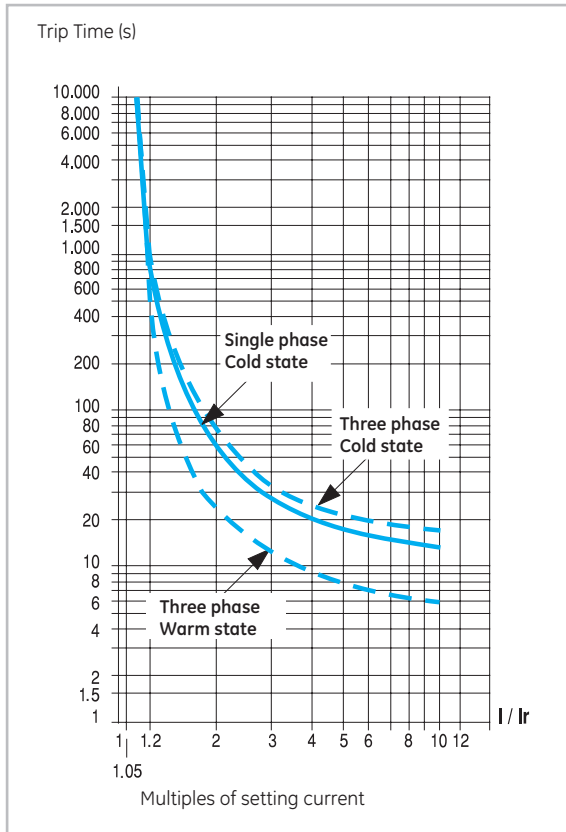

RT6L Class 30

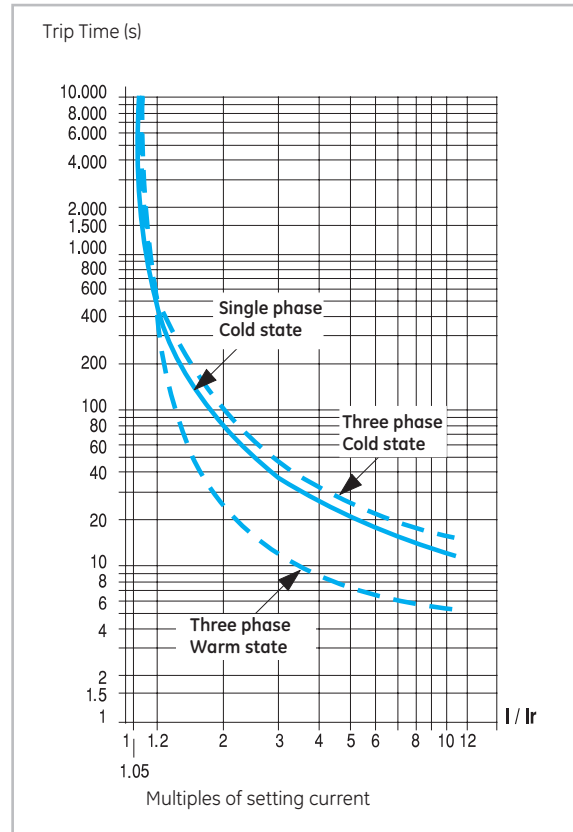

Series RT

Dimensional drawings

Thermal overload relay for contactors

RT1 - RT12
0.190 kg

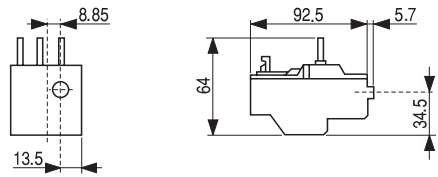

**RT1 + RT XP
RT12 + RTXP**

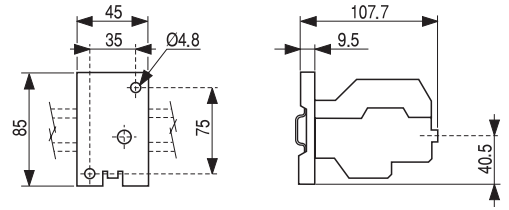

RT2 - RT22
0.400 kg

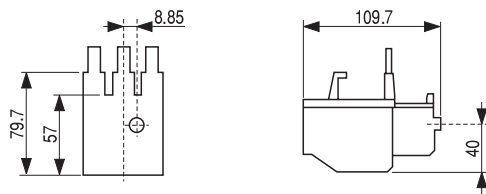

**RT2 + RT XP
RT22 + RTXP**

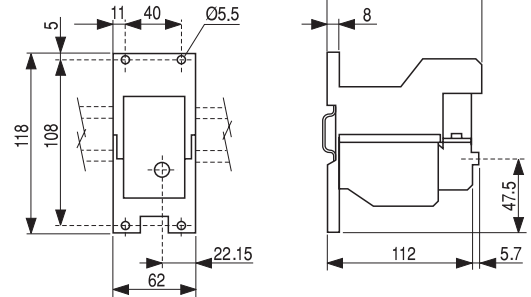

RT3 - RT32
0.900 kg

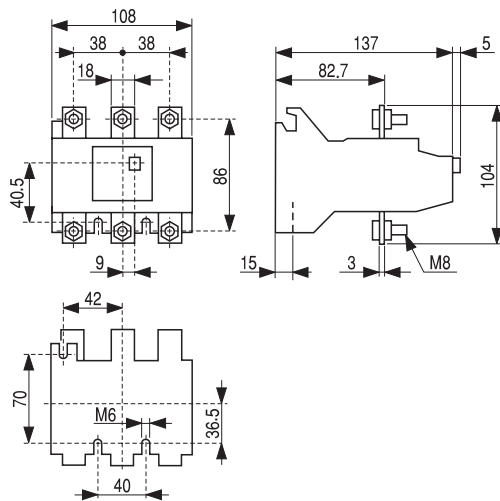

Dimensions in mm (inch = mm x 0.03937) - Weight in kg (lb = kg x 2.2046)



Thermal overload relay for contactors

RT4LA...RT4LM

2.400 kg

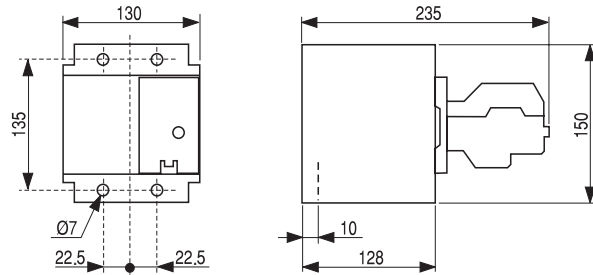

RT4/4LN...RT4/4LR

2.400 kg

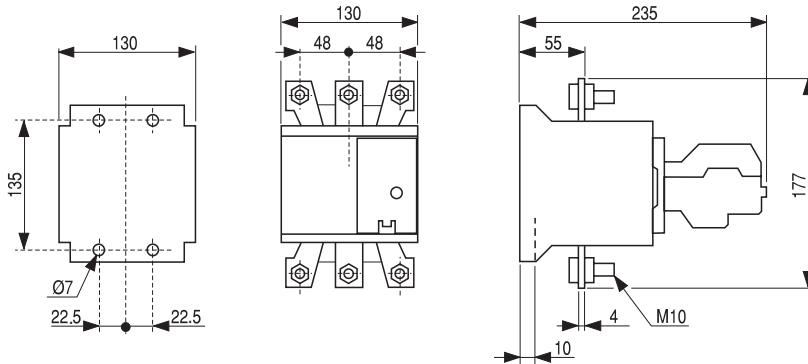

RT5 / 5L

0.875 kg

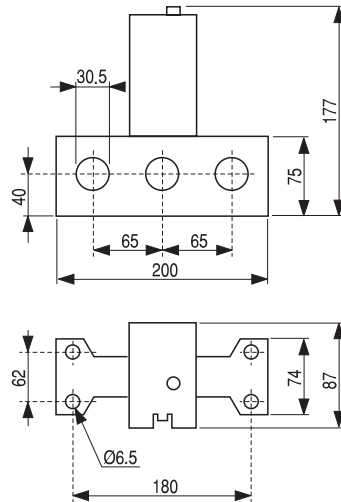

Remote electrical reset

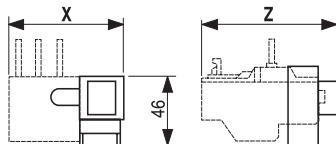

RTXRR + ...	X	Z
RT1	75	110
RT2	84	121
RT3	108	153
RT4	150	240
RT5	200	196

Dimensions in mm (inch = mm x 0.03937) - Weight in kg (lb = kg x 2.2046)

Dimensional drawings

Frame 1

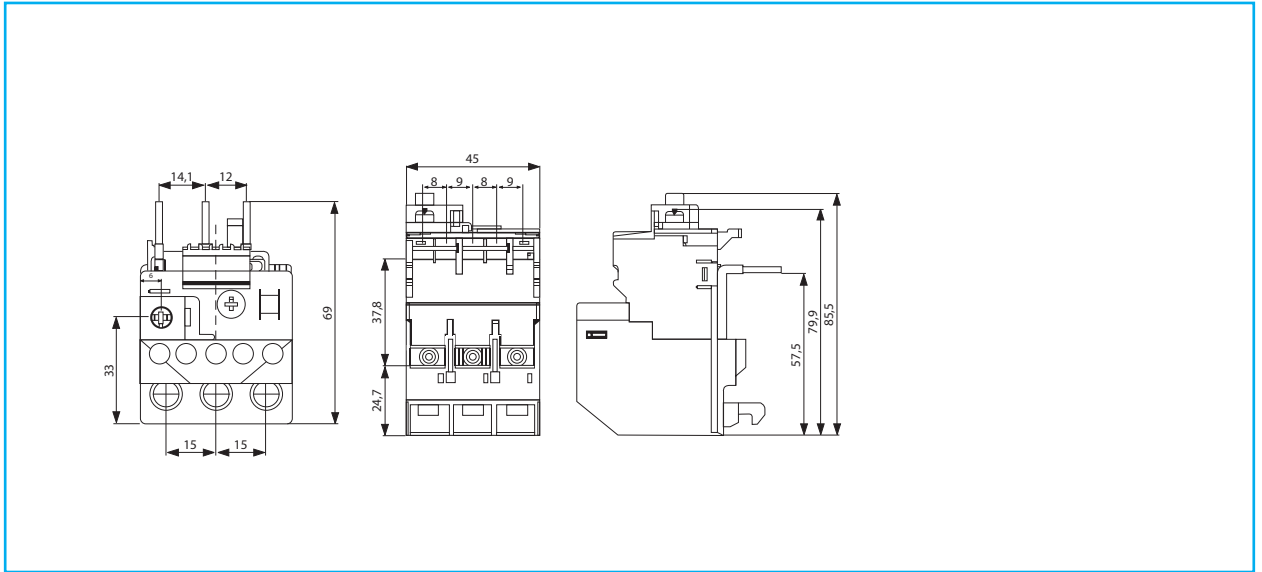

Frame 2

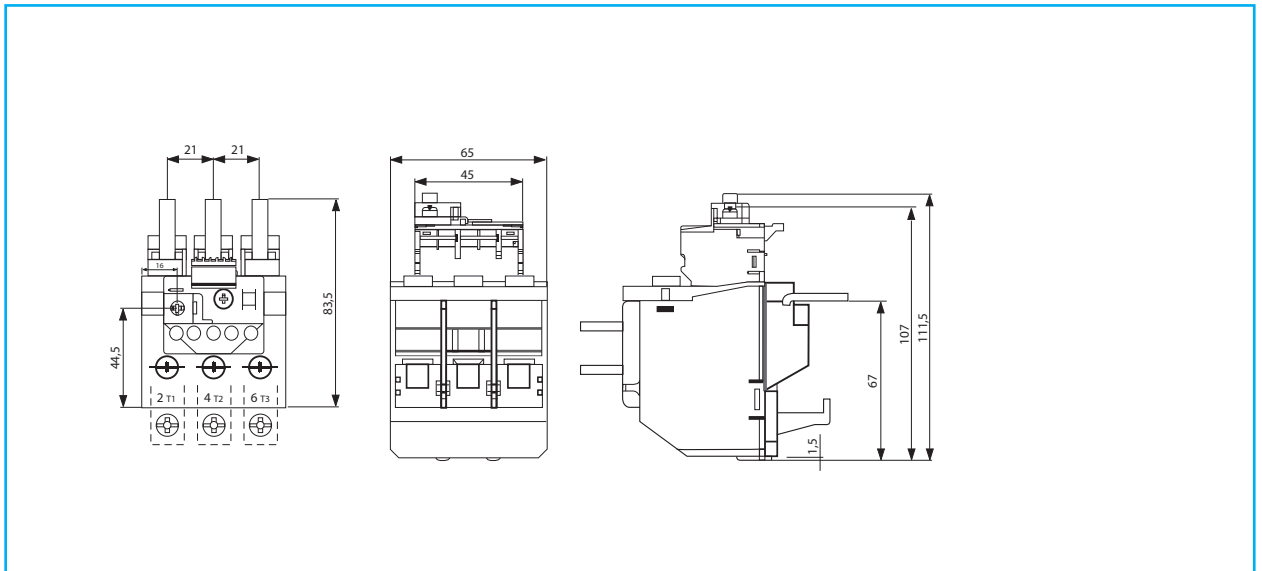

Frame 3

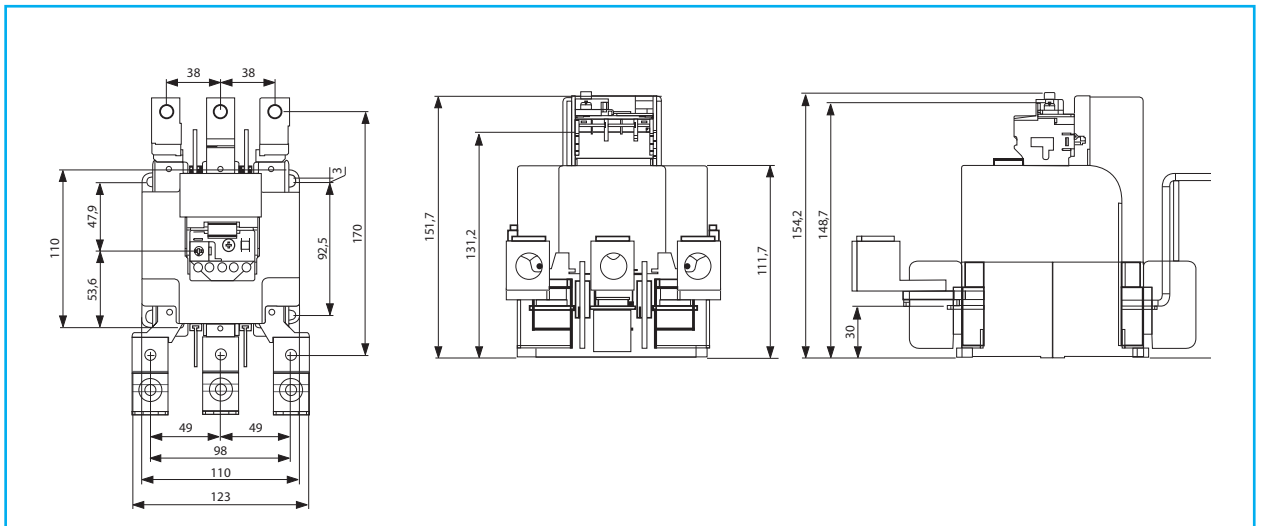

Dimensions in mm (inch = mm x 0.03937) - Weight in kg (lb = kg x 2.2046)

Dimensional drawings

Fuseless starter - GPS1 rocker + Minicontactor MC

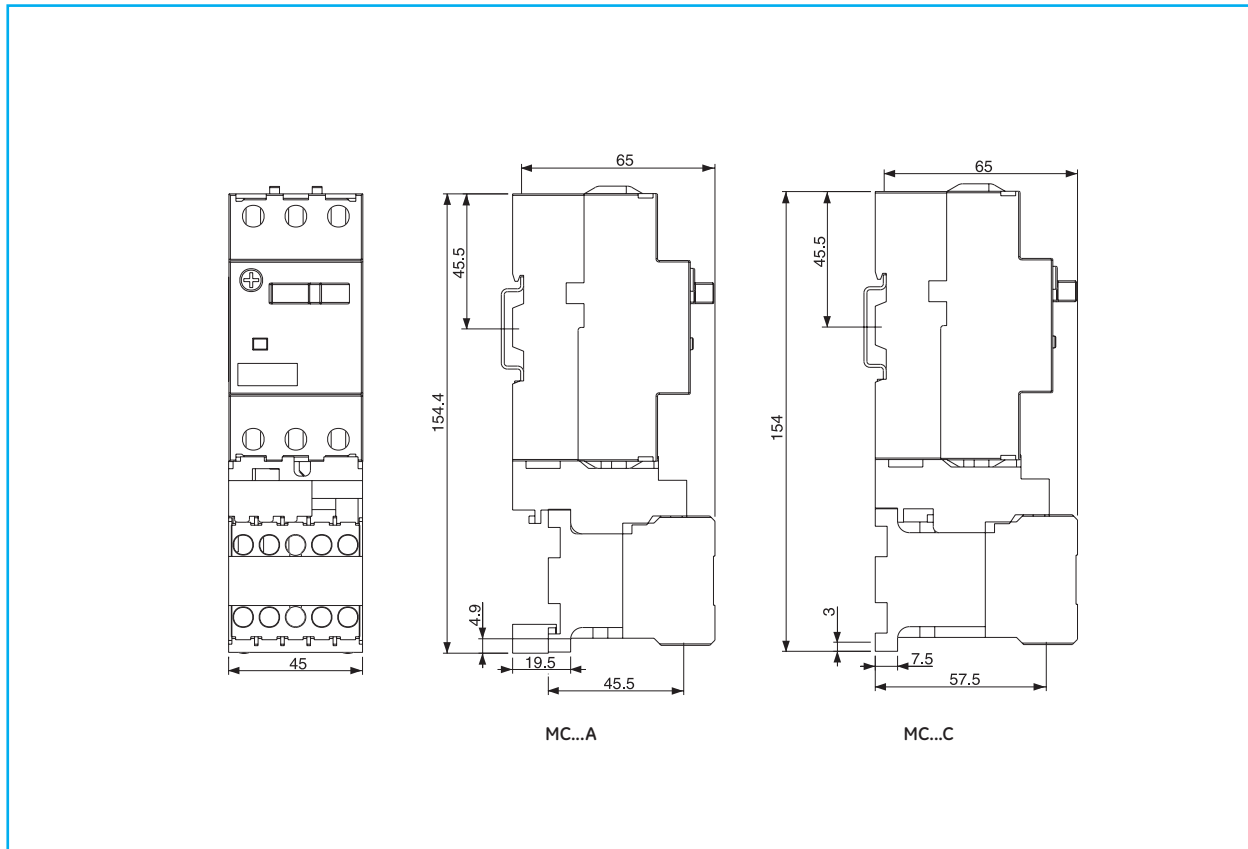

Fuseless starter - GPS1 rocker + Contactor CL00-CL01-CL02

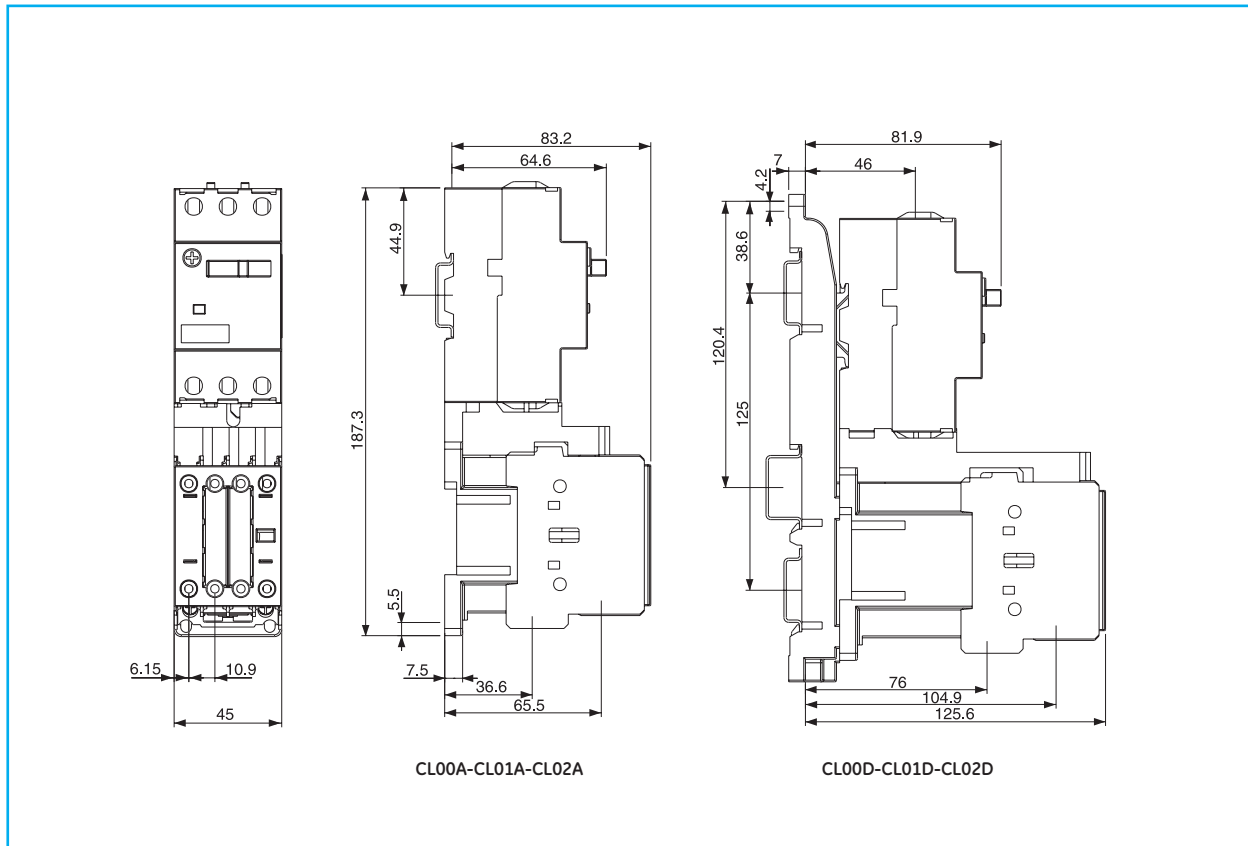

Fuseless starter - GPS1 rocker + Contactor CL03

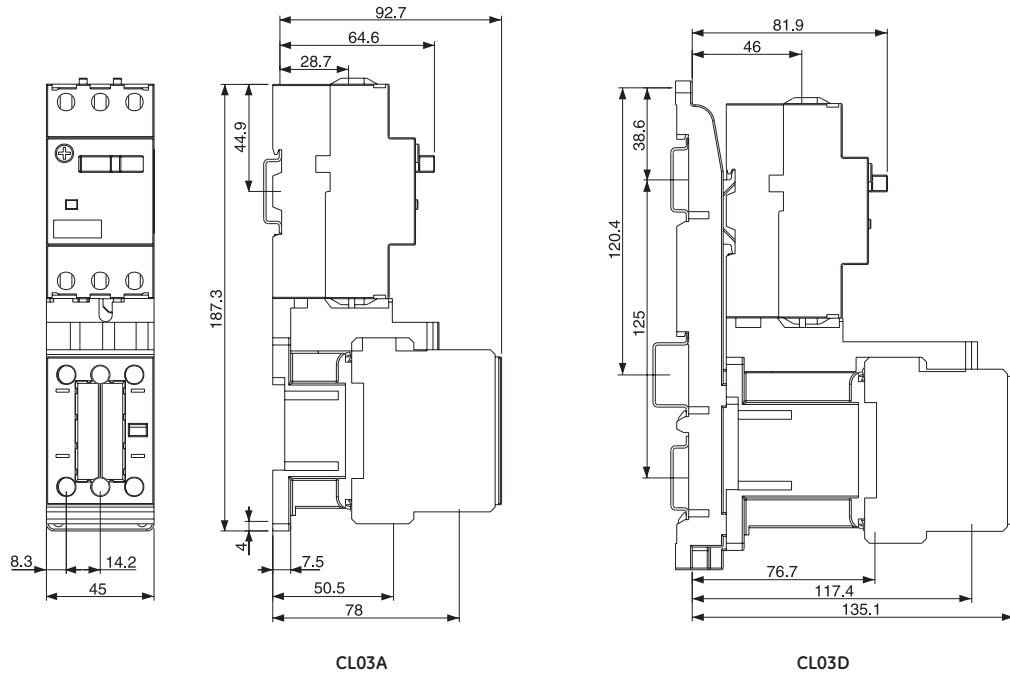

Fuseless starter - GPS2 + Contactor CL04

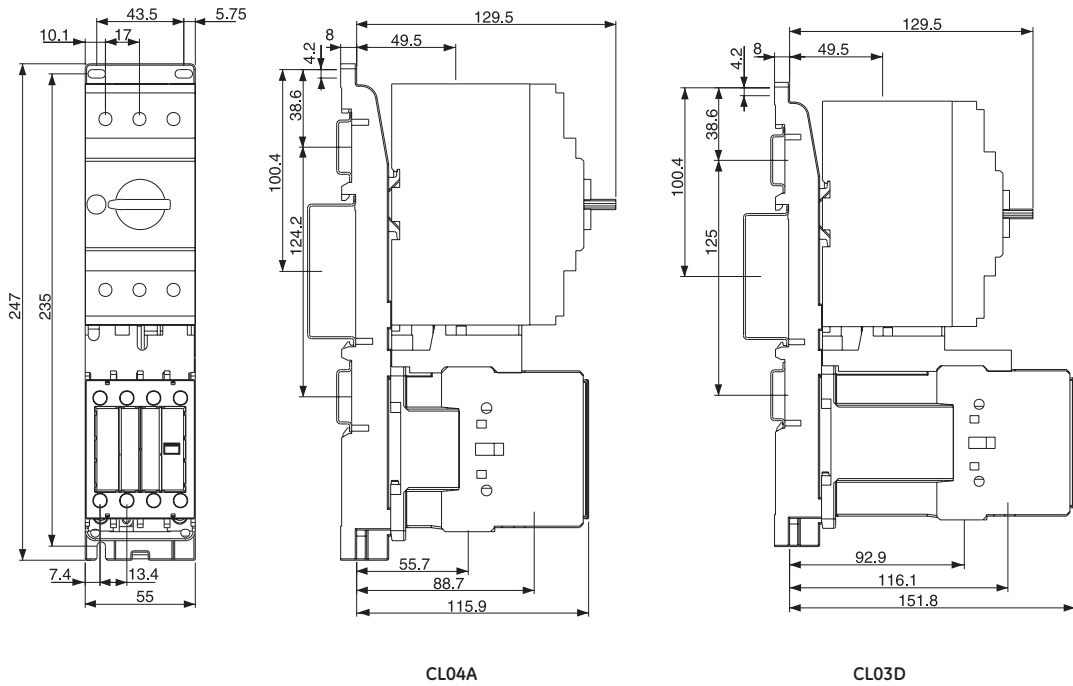

Dimensional drawings

Fuseless starter - GPS2 + Contactor CL05

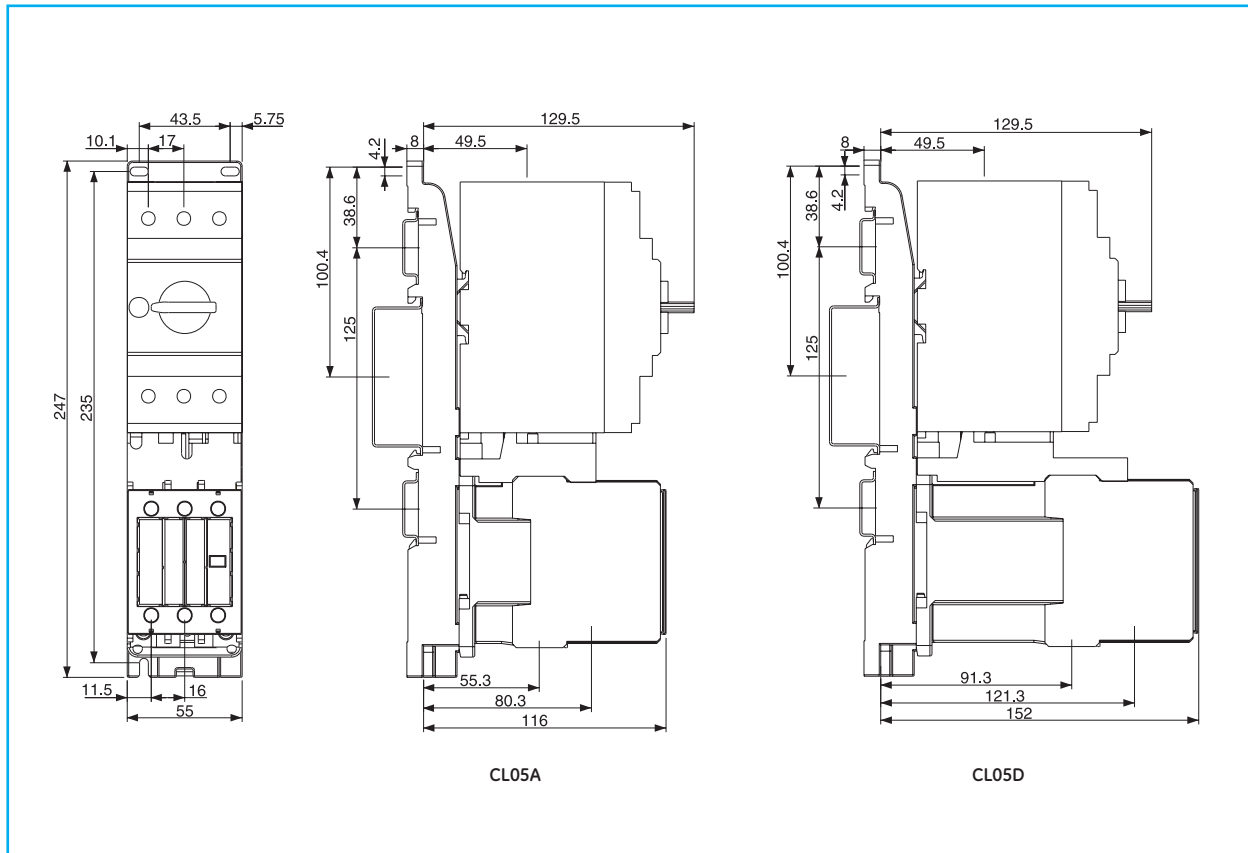

Fuseless starter - GPS2 + Contactor CL06-CL08

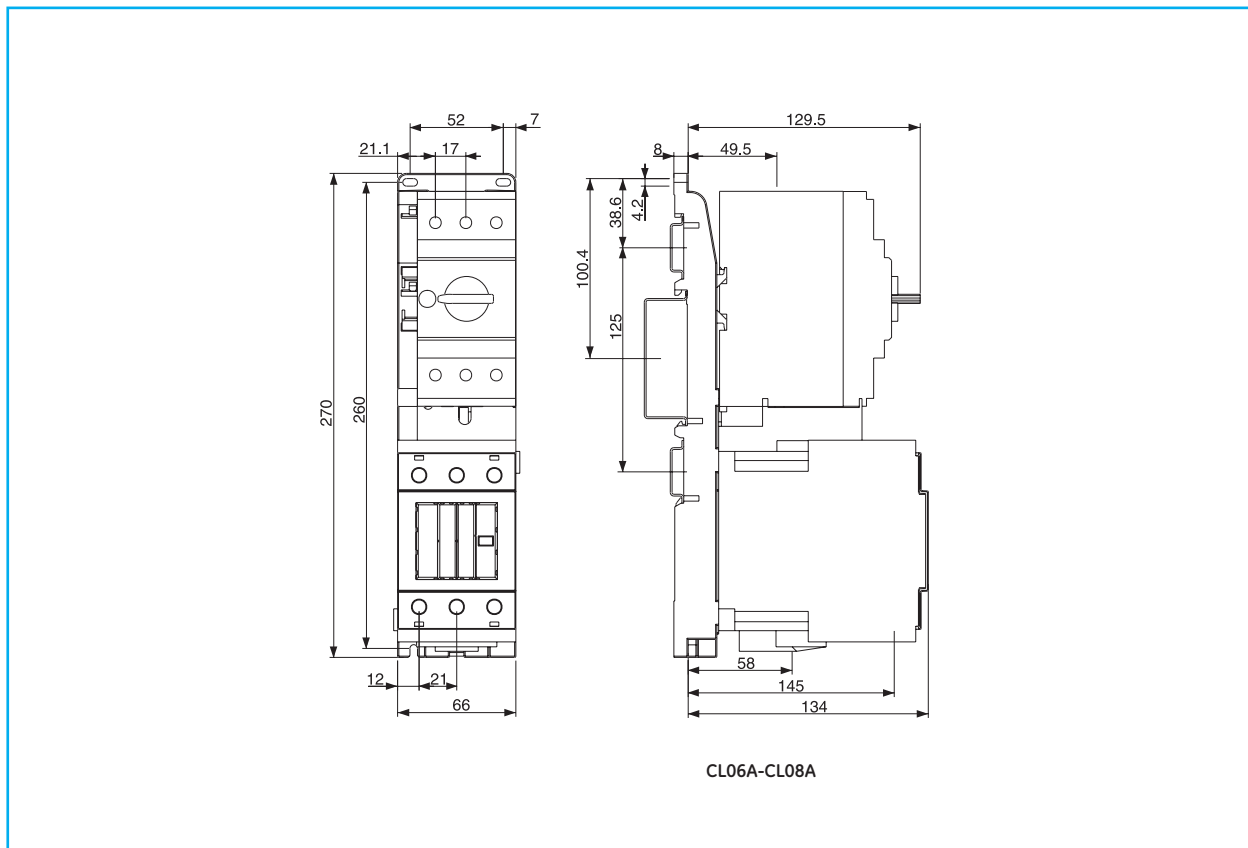

Dimensions

Intro

A

B

C

D

E

F

G

H

I

X



Fuseless starter - Record Plus + Contactor CL09 + Thermal overload relay RT2

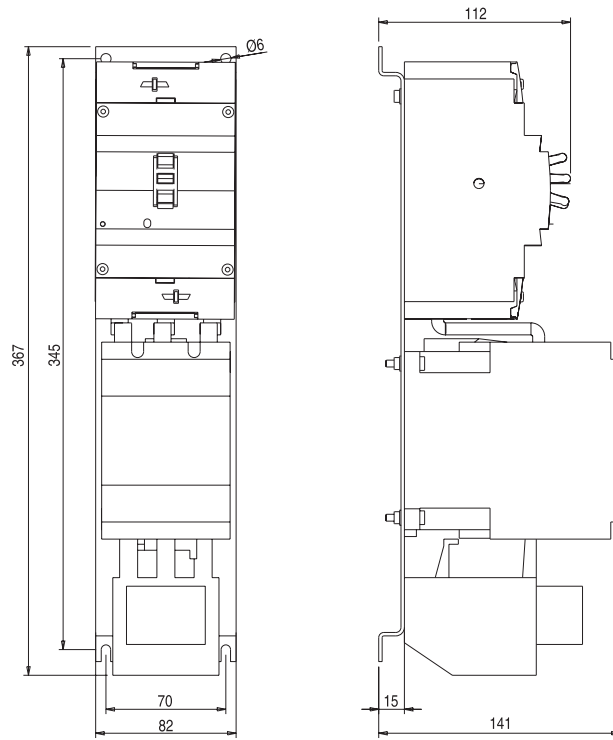

A

B

C

D

E

F

G

H

I

X



Dimensional drawings

Series CL - Direct-on-line starters

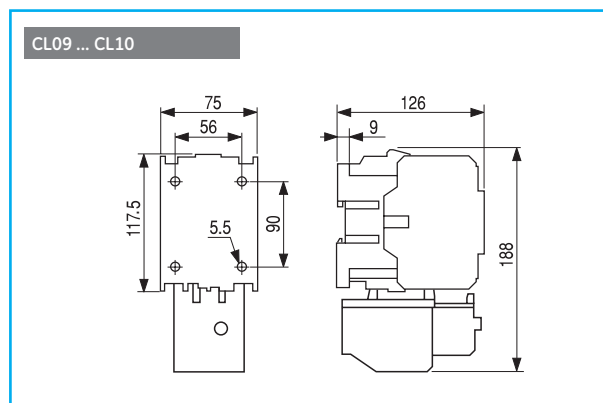
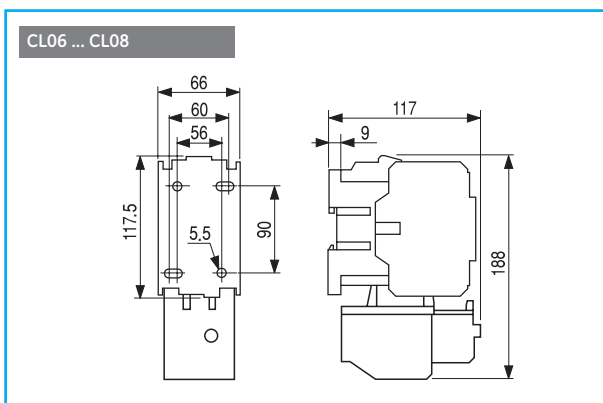
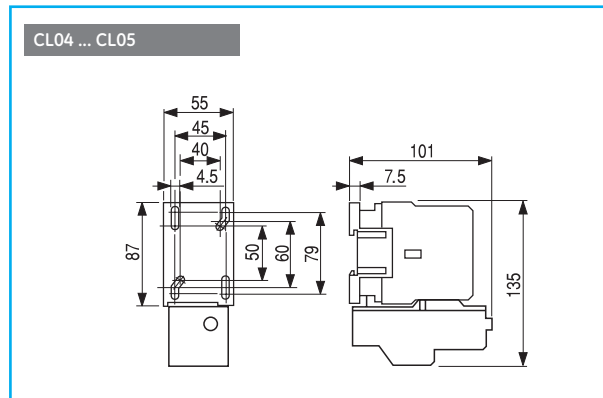
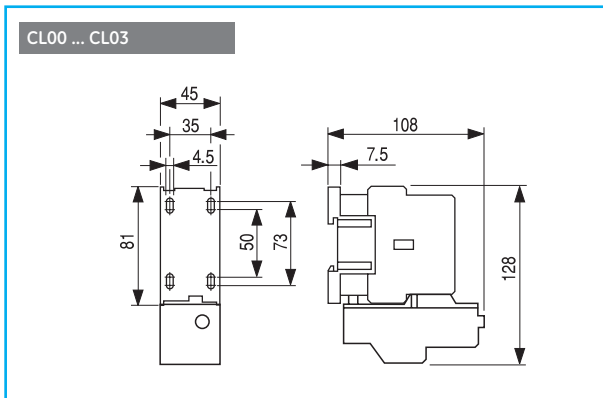

Series CK - Direct-on-line starters

CK75 ... CK08

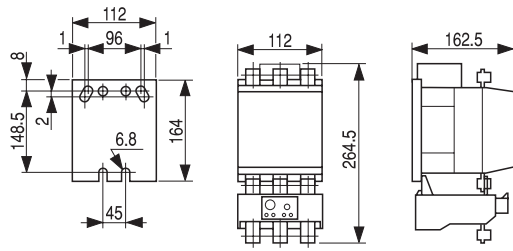

CK85 ... CK95

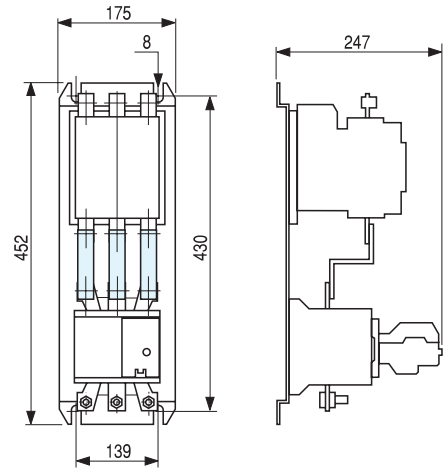

CK10 ... CK11

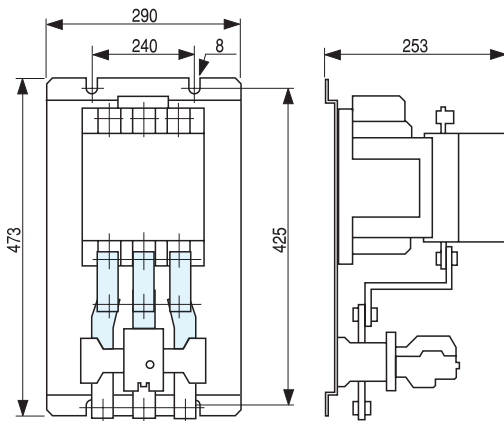

CK12

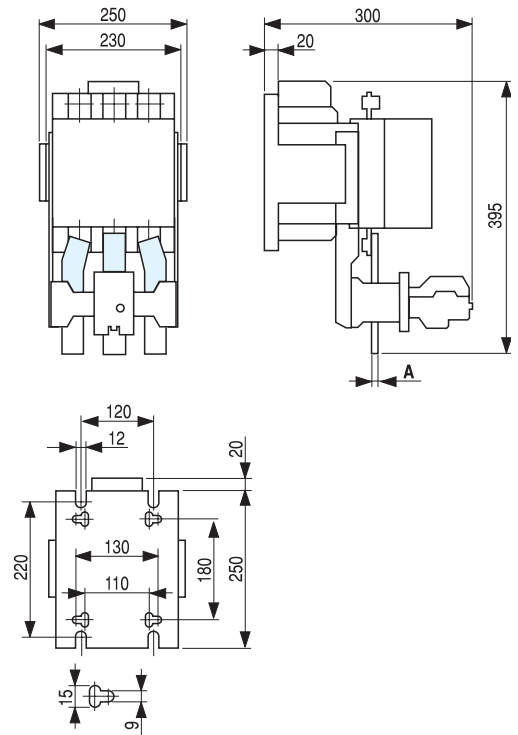

Dimensional drawings

Series M - Direct-on-line reversing starters

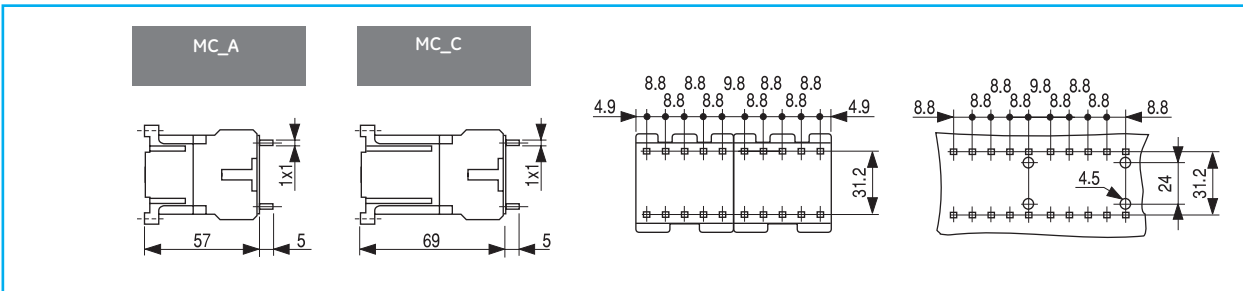
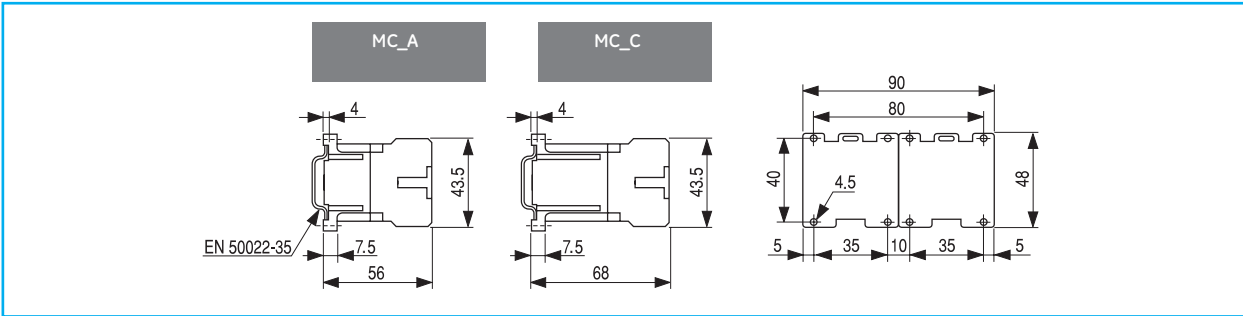

Series CL - Direct-on-line reversing starters without thermal overload relay

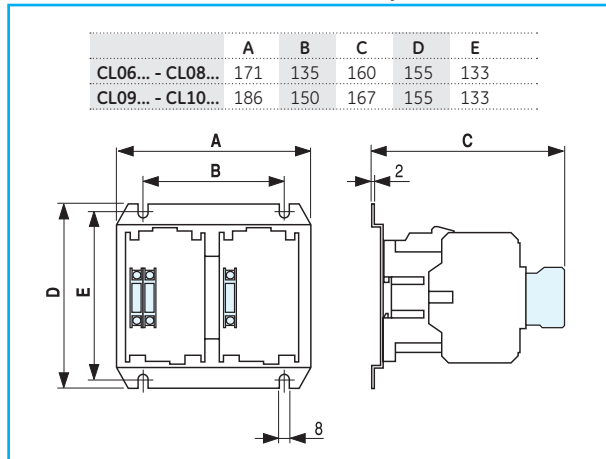
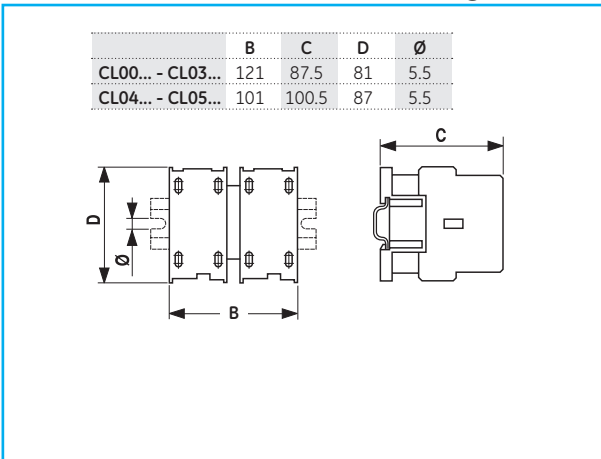

Series CL - Direct-on-line reversing starters with thermal overload relay

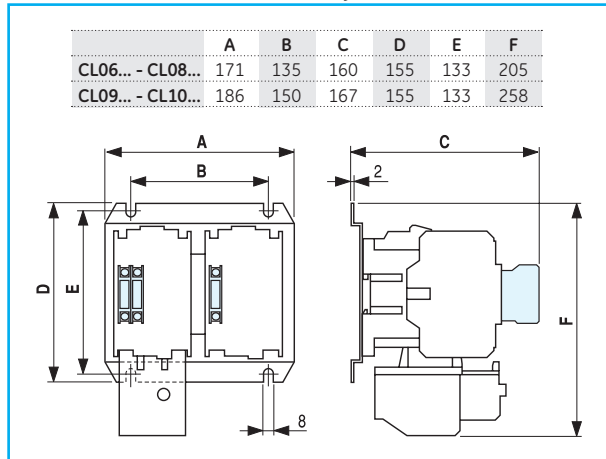
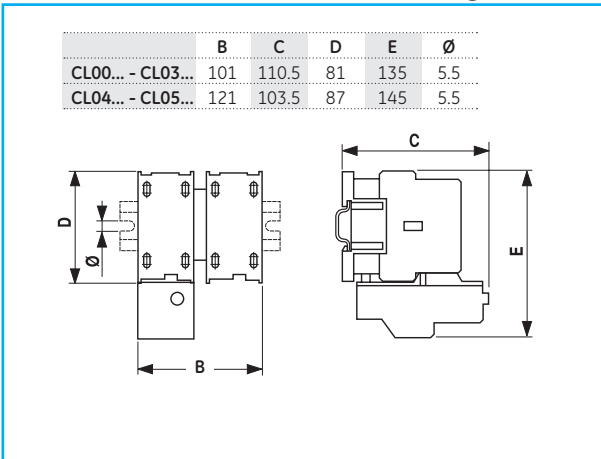

Series CK - Direct-on-line reversing starters without thermal overload relay

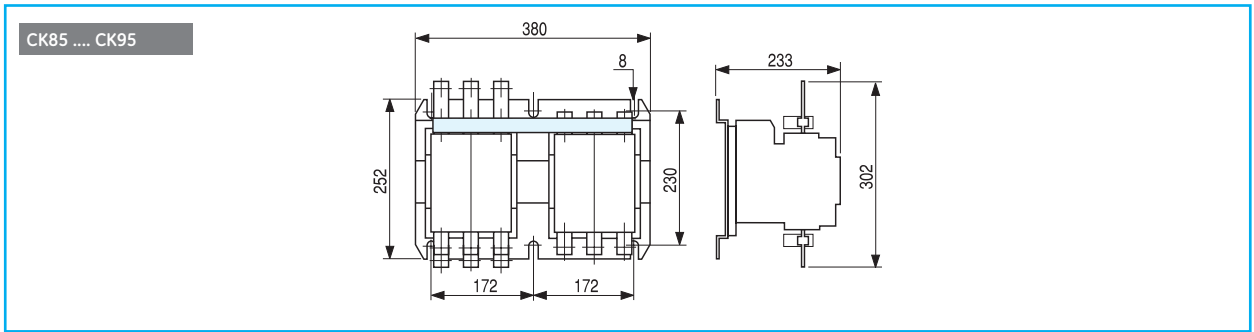
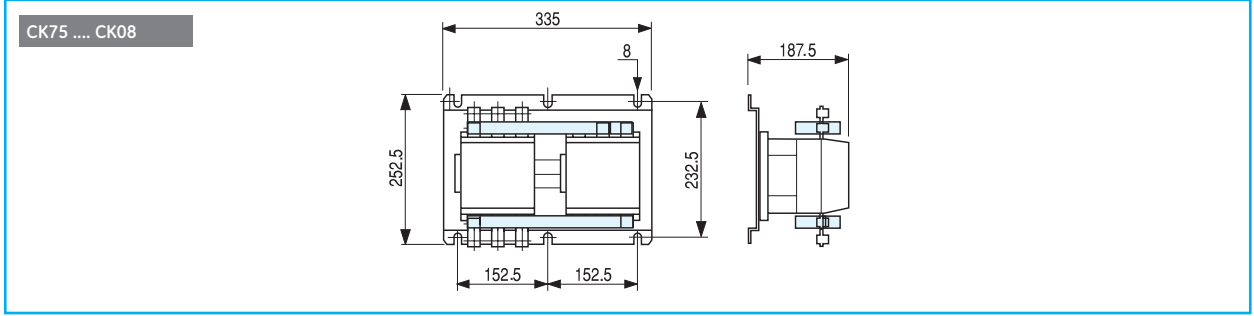

Series CK - Direct-on-line reversing starters with thermal overload relay

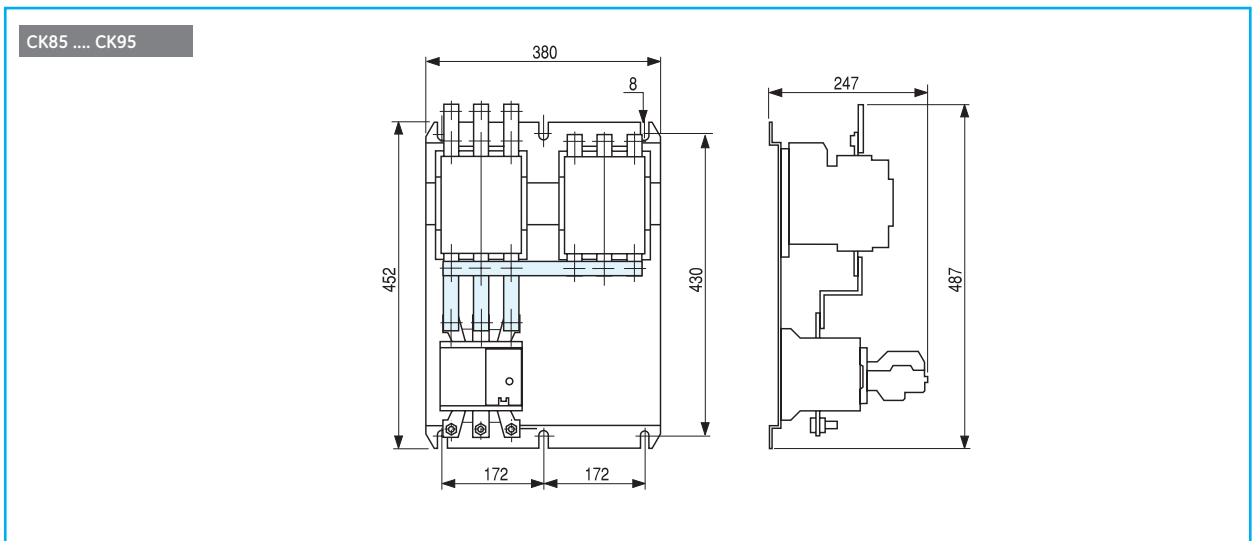
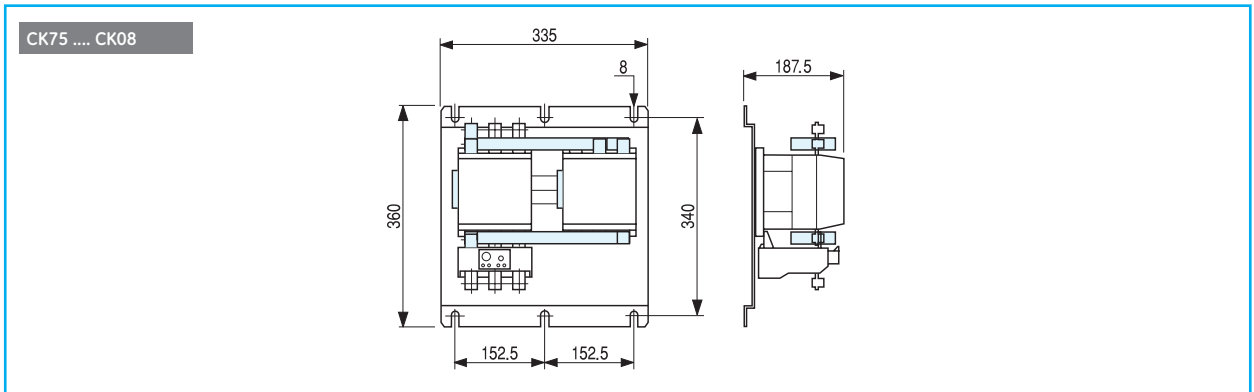

A

B

C

D

E

F

G

H

I

X



Dimensional drawings

Series CK - Direct-on-line reversing starters without thermal overload relay

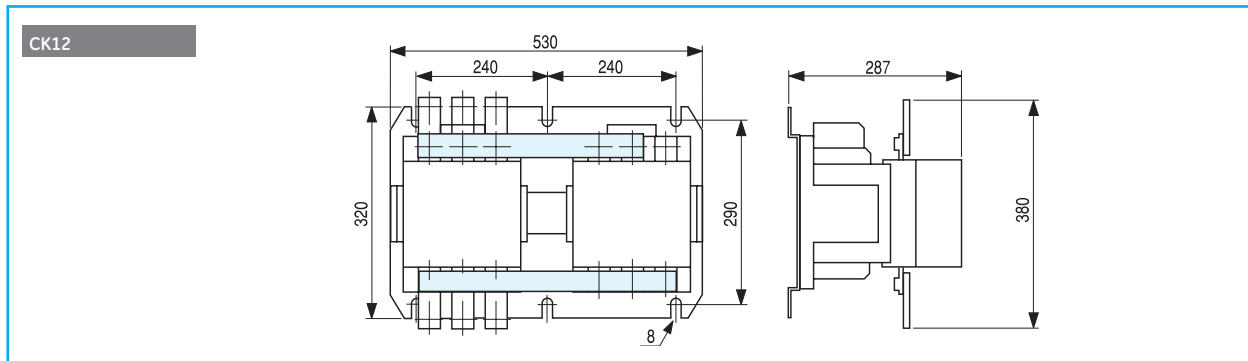
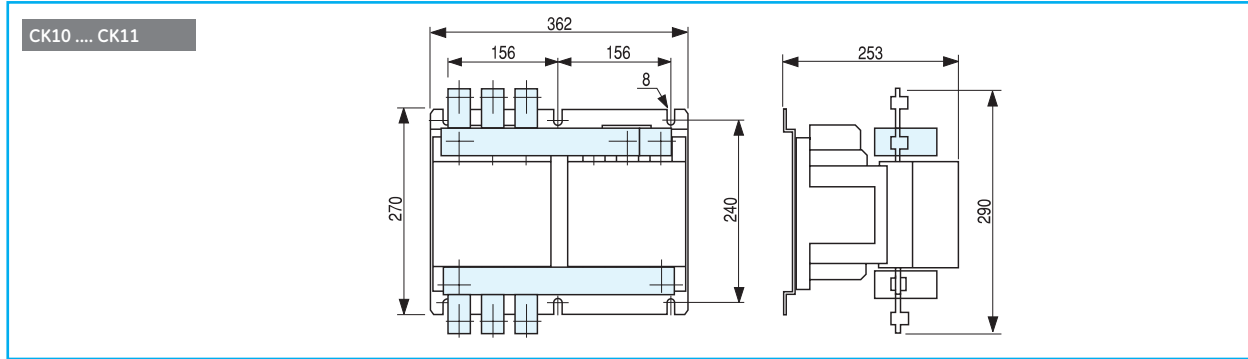

Series CK - Direct-on-line reversing starters with thermal overload relay

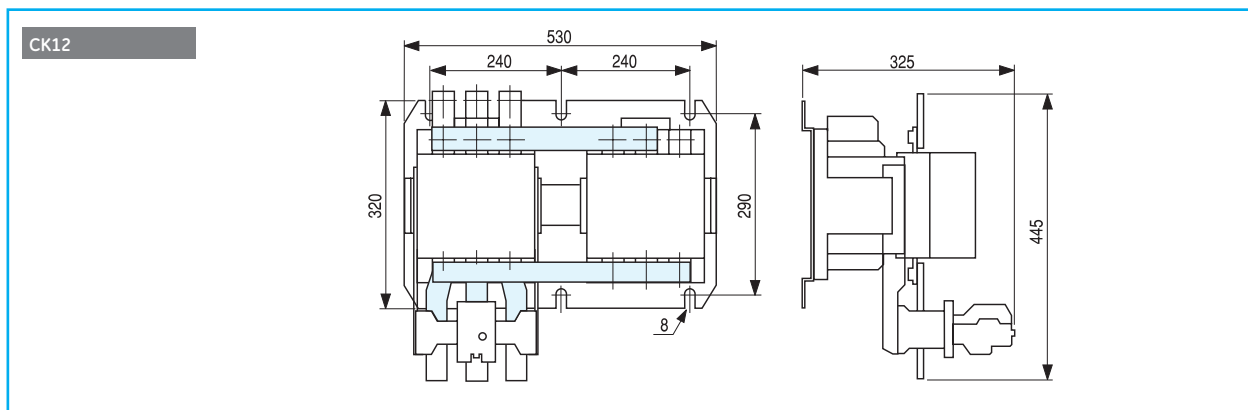
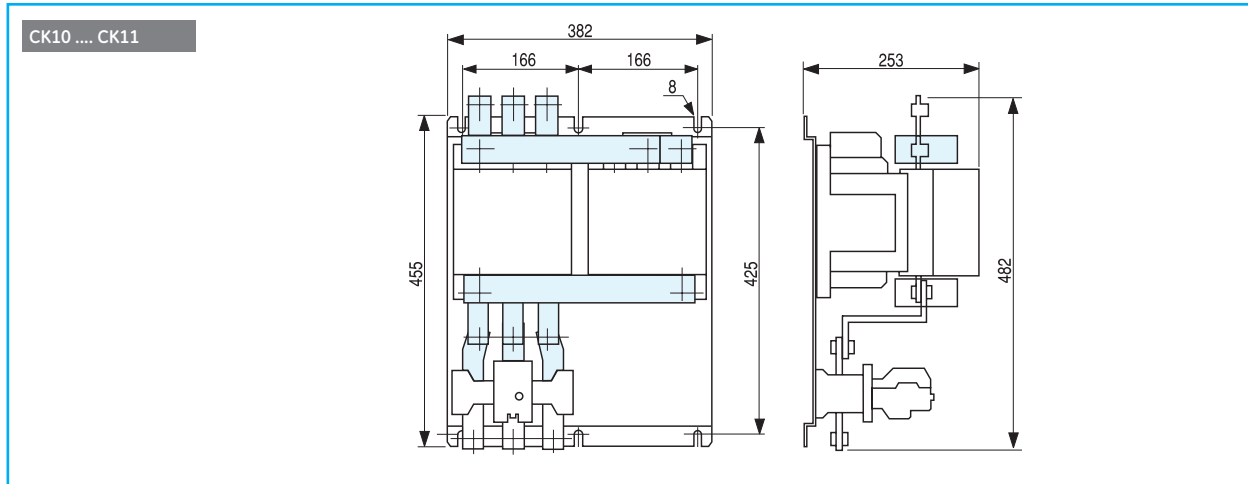

Series CL - Star-delta starters

	A	B	C	D
CL00... - CL03...	190	180	110.5	135
CL04...	220	210	103.5	145

	A	B	C	D	E	F
CL06... - CL08...	253	217	129	205	155	133
CL09...	263	247	138	247	155	133
CL10...	283	247	151	247	155	133

A

Series CK - Star-delta starters

CK75 ... CK08

CK85 ... CK95



Dimensional drawings

Series CK - Star-delta starters

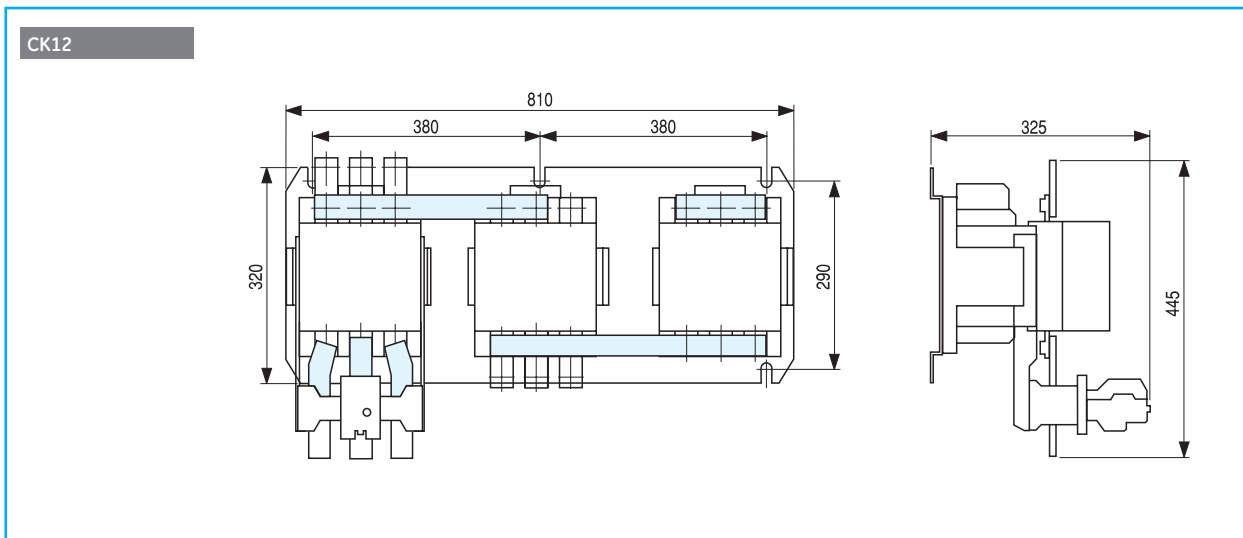
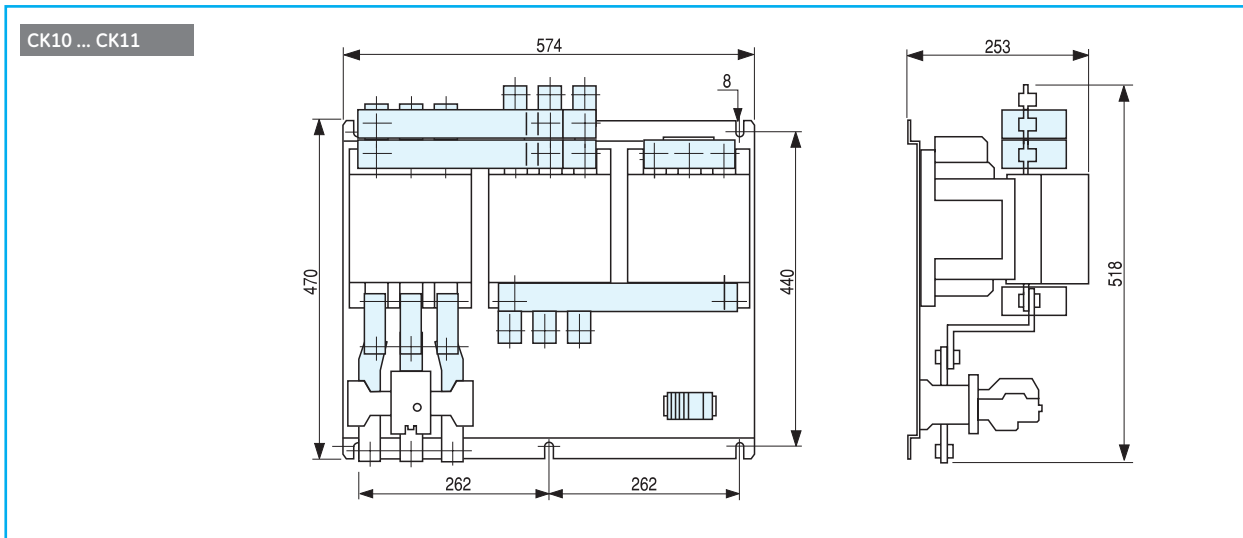

Everything is under control

Plug-in Relays and Auxiliary Contactors

Order codes

- B.2 Series PRC - Plug-in relays
- B.8 Series M - Auxiliary contactors
- B.14 Series RL - Auxiliary contactors
- B.17 Series EC - Auxiliary contactors

Series PRC - Plug-in relays

- B.20 Technical data
- B.27 Dimensions

Series M - Auxiliary contactors

- B.29 Technical data
- B.34 Terminal numbering
- B.37 Dimensions

Series RL - Auxiliary contactors

- B.39 Technical data
- B.42 Terminal numbering
- B.45 Dimensions

POWER DEVICES

Contactors and overload relays

Auxiliary relays and contactors

Effcor - Auxiliary contactors

- B.47 Technical data
- B.49 Terminal numbering
- B.51 Dimensions

Motor protection devices

Applications

AUXILIARY DEVICES

Main switches

Control and signalling units

POWER ELECTRONICS

Speed drive units

Soft starters

ENCLOSURES

Product overview

Alphabetical index

Intro

A

B

C

D

E

F

G

H

I

X



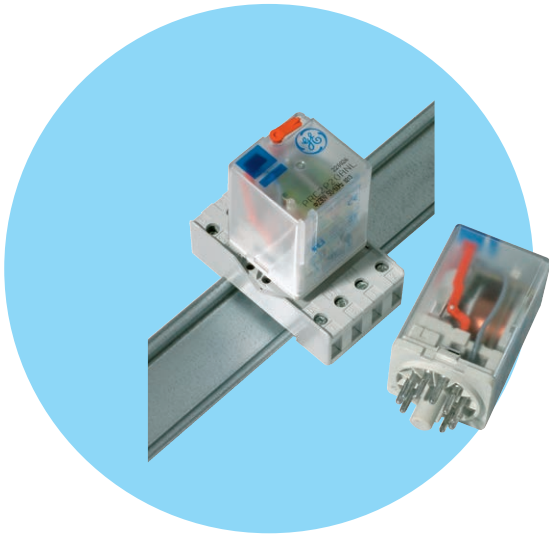

Plug-in auxiliary relays

- AC or DC coils
- Lockable test button with mechanical flag indicator.
- Sockets with rear 35mm rail (EN 50022) mounting.
- With LED indicator incorporated.

Miniature relays

Types	Poles	AC ratings	Sockets
PRC4M2...	2 CO	12A/250V	PRCG-ES15/2N
PRC4M3...	3 CO	10A/250V	PRCG-ES15/3N
PRC4M4...	4 CO	6A/250V	PRCG-ES15/4N

Standard 8-11 pin relays

Types	Poles	AC ratings	Sockets
PRC2P2...	2 CO	10A/250V	PRZ8
PRC3P3...	3 CO	10A/250V	PRZ11

Interface relay module

Types	Poles	AC ratings	Sockets
PRC1S1...	1 CO	6A/250V	-
For use with PLC systems			
PRC1T1...	1 CO	16A/250V	PRCGZT80
PRC1T2...	2 CO	8A/250V	PRCGZT80

Approvals

According to types:

Plug-in relays	Sockets
CE	CE
cUL	cUL
VDE	

Catalogue number structure

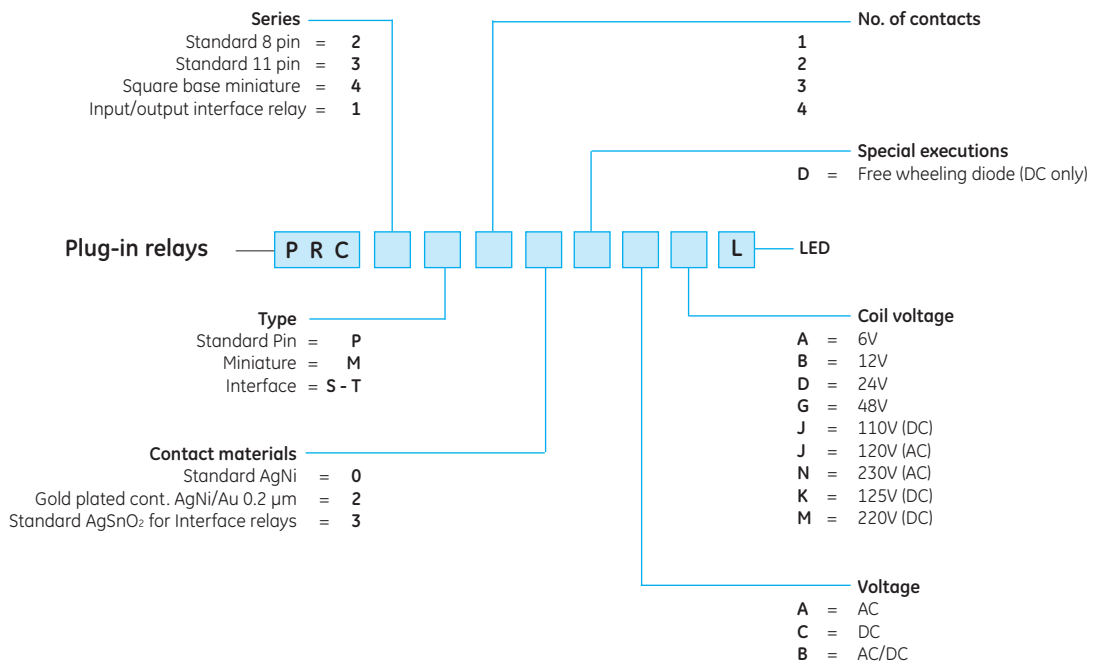

- Order codes ● page B.3
- Modules for sockets ● page B.6
- Technical characteristics ● page B.20
- Dimensions ● page B.27



Miniature plug-in relays



	Ratings AC	Contacts Standard material	Voltage		with LED		Pack.
					Cat. no.	Ref. no.	
2 changeover contacts	12A/250V	0 AgNi	AC 50/60Hz	12V	PRC4M20ABL	220710	10
				24V	PRC4M20ADL	220711	10
				48V	PRC4M20AGL	220712	10
				120V	PRC4M20AJL	220715	10
				230V	PRC4M20ANL	220717	10
				DC	12V	PRC4M20CBL	220713
			24V		PRC4M20CDL	220714	10
			48V		PRC4M20CGL	220716	10
			110V		PRC4M20CJL	220718	10
			125V		PRC4M20CKL	220029	10
			220V		PRC4M20CML	220046	10
			DC Diode	12V	PRC4M20DCBL	220754	10
				24V	PRC4M20DCDL	220755	10
				48V	PRC4M20DCGL	220756	10
				110V	PRC4M20DCJL	220757	10
				125V	PRC4M20DCKL	220028	10
	220V	PRC4M20DCML	220045	10			
3 changeover contacts	10A/250V	0 AgNi	AC 50/60Hz	12V	PRC4M30ABL	221051	10
				24V	PRC4M30ADL	221052	10
				48V	PRC4M30AGL	221053	10
				120V	PRC4M30AJL	221056	10
				230V	PRC4M30ANL	221058	10
				DC	12V	PRC4M30CBL	221054
			24V		PRC4M30CDL	221055	10
			48V		PRC4M30CGL	221057	10
			110V		PRC4M30CJL	221059	10
			125V		PRC4M30CKL	220031	10
			220V		PRC4M30CML	220048	10
			DC Diode	12V	PRC4M30DCBL	221074	10
				24V	PRC4M30DCDL	221075	10
				48V	PRC4M30DCGL	221076	10
				110V	PRC4M30DCJL	221077	10
				125V	PRC4M30DCKL	220030	10
	220V	PRC4M30DCML	220047	10			
4 changeover contacts	6A/250V	0 AgNi	AC 50/60Hz	12V	PRC4M40ABL	221809	10
				24V	PRC4M40ADL	221810	10
				48V	PRC4M40AGL	221811	10
				120V	PRC4M40AJL	221814	10
				230V	PRC4M40ANL	221816	10
				DC	12V	PRC4M40CBL	221812
			24V		PRC4M40CDL	221813	10
			48V		PRC4M40CGL	221815	10
			110V		PRC4M40CJL	221817	10
			125V		PRC4M40CKL	220033	10
			220V		PRC4M40CML	220050	10
			DC Diode	12V	PRC4M40DCBL	221851	10
				24V	PRC4M40DCDL	221852	10
				48V	PRC4M40DCGL	221853	10
				110V	PRC4M40DCJL	221854	10
				125V	PRC4M40DCKL	220032	10
	220V	PRC4M40DCML	220049	10			

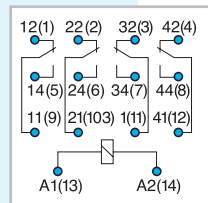
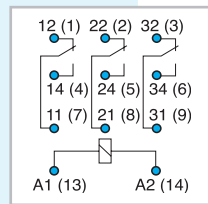
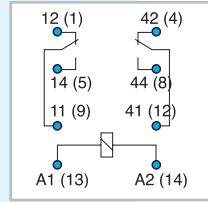

Sockets



				Cat. no.	Ref. no.	Pack.
For PRC4M2... 2 changeover contacts	Screw terminals Two levels	Socket Fixing clip Retainer/Extractor Identification plate	Metal White plastic	PRCG-ES15/2N	220912	10
				PRCG1052	220914	10
				PRCMS35	220915	10
				PRCTR1	220916	10
For PRC4M3... 3 changeover contacts	Screw terminals Two levels	Socket Fixing clip Retainer/Extractor Identification plate	Metal White plastic	PRCG-ES15/3N	221442	10
				PRCG1052	220914	10
				PRCMS35	220915	10
				PRCTR1	220916	10
For PRC4M4... 4 changeover contacts	Screw terminals Two levels	Socket Fixing clip Retainer/Extractor Identification plate	Metal White plastic	PRCG-ES15/4N	221934	10
				PRCG1052	220914	10
				PRCMS35	220915	10
				PRCTR1	220916	10

Order codes

Intro

A

B

C

D

E

F

G

H

I

X



Standard 8-11 pin plug-in relays

Standard 8 pin
2 changeover contacts



Ratings
AC

10A/250V

Contacts
Standard material

0
AgNi

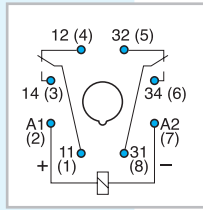

Voltage

AC

50/60Hz

12V

24V

48V

120V

230V

DC

12V

24V

48V

110V

DC Diode

12V

24V

48V

110V

with LED

Cat. no.

Ref. no.

Pack.

PRC2P20ABL

220019

10

PRC2P20ADL

220020

10

PRC2P20AGL

220021

10

PRC2P20AJL

220024

10

PRC2P20ANL

220026

10

PRC2P20CBL

220022

10

PRC2P20CDL

220023

10

PRC2P20CGL

220025

10

PRC2P20CJL

220027

10

PRC2P20DCBL

220041

10

PRC2P20DCDL

220042

10

PRC2P20DCGL

220043

10

PRC2P20DCJL

220044

10

Standard 11 pin
3 changeover contacts



10A/250V

0
AgNi

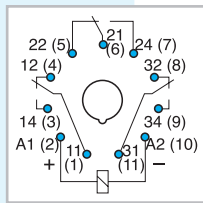

AC

50/60Hz

12V

24V

48V

120V

230V

DC

12V

24V

48V

110V

DC Diode

12V

24V

48V

110V

PRC3P30ABL

220310

10

PRC3P30ADL

220311

10

PRC3P30AGL

220312

10

PRC3P30AJL

220315

10

PRC3P30ANL

220317

10

PRC3P30CBL

220313

10

PRC3P30CDL

220314

10

PRC3P30CGL

220316

10

PRC3P30CJL

220318

10

PRC3P30DCBL

220335

10

PRC3P30DCDL

220336

10

PRC3P30DCGL

220337

10

PRC3P30DCJL

220338

10

Sockets

For PRC2P20...
Standard 8 pin



Screw terminals
One level

Socket
Fixing clip

Cat. no.

Ref. no.

Pack.

PRCZ8

220216

10

PRCPZ11

220218

10

Solder terminal

Socket
Fixing clip

PRCG8

220217

10

PRCR159

220219

10

For PRC3P30...
Standard 11 pin

Screw terminals
One level

Socket
Fixing clip

PRCZ11

220647

10

PRCPZ11

220218

10

Solder terminal

Socket
Fixing clip

PRCG11

220648

10

PRCR159

220219

10

Interface relay

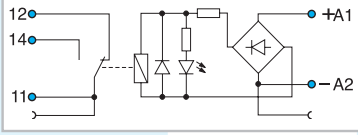

	Ratings AC1	Ratings DC1	Voltage		with LED		Pack.
					Cat. no.	Ref. no.	
6.2mm wide							
 1 single pole 1 changeover contact	6A/250V	-	AC/DC	230V	PRC1S13BNL	222013	10
				12V	PRC1S13CBL	222007	10
			24V	PRC1S13CDL	222008	10	
			AC/DC	24V	PRC1S13BDL	222004	10
							

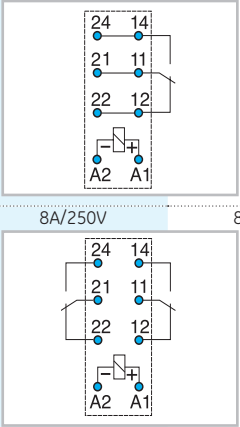
Interface relay for PLC systems

	Ratings AC1	Ratings DC1	Voltage		with LED		Pack.
					Cat. no.	Ref. no.	
 1 changeover contact	16A/250V	16A/24V	AC	24V	PRC1T10ADL	221868	10
				120V	PRC1T10AJL	221869	10
				230V	PRC1T10ANL	221870	10
			DC	12V	PRC1T10CBL	221860	10
				24V	PRC1T10CDL	221861	10
				110V	PRC1T10CJL	221862	10
 2 changeover contacts	8A/250V	8A/24V	AC	24V	PRC1T20ADL	221883	10
				120V	PRC1T20AJL	221884	10
				230V	PRC1T20ANL	221885	10
			DC	12V	PRC1T20CBL	221875	10
				24V	PRC1T20CDL	221876	10
				110V	PRC1T20CJL	221877	10
							

Complete set of relay, socket, module (diode+Led for DC-Varistor + Led for AC) and retaining clip + marking plate. 16mm width

Spare parts

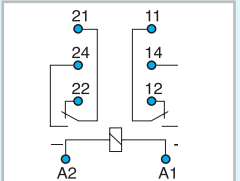
		Voltage		Cat. no.	Ref. no.	Pack.	
 1 changeover contact	Miniature P.C.B. relays. 16A	AC 50/60Hz	24V	PRCT1AD	221896	20	
			120V	PRCT1AJ	221897	20	
			230V	PRCT1AN	221898	20	
		DC	12V	PRCT1CB	221890	20	
			24V	PRCT1CD	221891	20	
			110V	PRCT1CJ	221892	20	
 2 changeover contacts	Miniature P.C.B. relays. 8A	AC 50/60Hz	24V	PRCT2AD	221913	20	
			120V	PRCT2AJ	221914	20	
			230V	PRCT2AN	221915	20	
		DC	12V	PRCT2CB	221905	20	
			24V	PRCT2CD	221906	20	
			110V	PRCT2CJ	221907	20	
Socket for miniature P.C.B. relays							
	Three level screws			PRCGZT80	221918	10	
	Retainer/Retractor Plate			PRCMS16 PRCTR	221920 221921	10 10	
							

NOTE: If more than 12A are applied to the relay contact, twin wiring is required. See the connection diagram of the relay



Modules for sockets

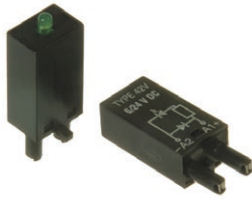

				Color LED	Cat. no.	Ref. no.	Pack.
Diode	Protection against polarity inversion						
	For use with sockets: PRCG-ES15/2N PRCG-ES15/3N PRCG-ES15/4N PRCGZT80		6 / 230V DC		PRCM21P	222100	10
			6 / 230V DC		PRCM21N	222101	10
Diode and LED	Protection against polarity inversion Coil energizing indication						
	For use with sockets: PRCG-ES15/2N PRCG-ES15/3N PRCG-ES15/4N PRCGZT80		6 / 24V DC	Red	PRCM31R	222102	10
				Green	PRCM31G	222104	10
			24 / 60V DC	Red	PRCM32R	222103	10
				Green	PRCM32G	222105	10
			110 / 230V DC	Red	PRCM33R	222109	10
				Green	PRCM33G	222106	10
			6 / 24V DC	Red	PRCM41R	222110	10
				Green	PRCM41G	222107	10
			24 / 60V DC	Red	PRCM42R	222111	10
			Green	PRCM42G	222124	10	
			110 / 230V DC	Red	PRCM43R	222112	10
				Green	PRCM43G	222125	10
RC group	Arc suppression circuit						
	For use with sockets: PRCG-ES15/2N PRCG-ES15/3N PRCG-ES15/4N PRCGZT80		6 / 24V AC		PRCM51	222113	10
			24 / 60V AC		PRCM52	222114	10
110 / 240V AC				PRCM53	222115	10	
LED and varistor	No protection against polarity inversion Coil energizing indication AC/DC voltage allowed						
	For use with sockets: PRCG-ES15/2N PRCG-ES15/3N PRCG-ES15/4N PRCGZT80		6 / 24V AC	Red	PRCM91R	222116	10
				Green	PRCM91G	222126	10
110 / 230V AC			Green	PRCM93G	222120	10	
Varistor group	No indication Protection against overvoltage						
	For use with sockets: PRCG-ES15/2N PRCG-ES15/3N PRCG-ES15/4N PRCGZT80		24V AC 230V AC		PRCM71 PRCM73	222121 222122	10 10



Everything is under control

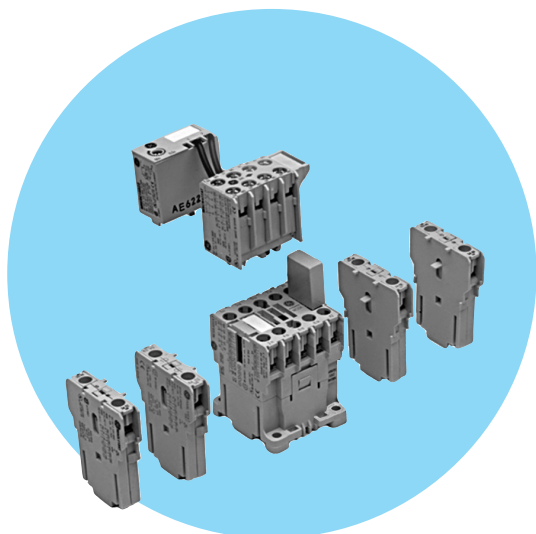

Auxiliary contactors $I_{th} = 16A$

- Control circuit: Alternating current up to 600V
Direct current up to 250V
- Terminal numbering in accordance with EN 50011
- Fixing system for rapid and simple mounting by clamping onto standard 35mm DIN rail (EN 50022).
- 6kV rated impulse withstand strength
- Screw and push-on terminals protected against accidental contacts in accordance with VDE 0106 T.100 and VBG4.
- Printed circuit version.
- Ring terminal version.
- Facility to mount instant or timed auxiliary contact blocks and voltage suppressor blocks.
- Maximum number of auxiliary contacts to add: 6
- Degree of protection IP20 (EN 60529).
- According to IEC/EN 60947-1.

Standards

IEC/EN 60947-5-1	BS 4794
IEC/EN 60947-1	CENELEC HD 420
EN 50002	NFC 63-110
EN 50005	NFC 63-140
EN 50011	CSA C22.2/14
UL 508	VDE 0660

General data

Maximum number of contacts (MCR...)	4
Rated thermal current (I_{th}) $\theta \leq 60^\circ$	(A) 16
Rated operational voltage (U_e) acc. IEC 60947-1	(V) 690
Insulation voltage (U_i) acc. IEC 60947-1	(V) 750

Utilisation category:

AC-15	V	110	220/240	380/400	415	440	500	660/690
	A	6	6	4	4	3	2.5	1.5

DC-13	V	24	48	110	220
	A	5	3.5	1.2	0.6

Approvals



cULus

CE



Lloyd's Register



Bureau Veritas



RINA

Standard voltages

To complete the catalogue number, replace the symbol \blacklozenge by the code corresponding to the voltage and frequency of the control circuit.

AC Coils

AC	1	2	9	J	K	M	6	7	N	U	W	Y
50/60Hz	24	42	48				220-230	240				
50 Hz				110-115	115-127					380-400	415-440	500
60Hz				110-120		208-220			277	440	480	600

Voltage operating limits of dual-frequency coil:

at 60Hz = $0.85 \text{ a } 1.1 \times U_s$

at 50Hz = $0.8 \text{ a } 1.1 \times U_s$ for uninterrupted duty (ED=100%), temperature = 40°C

DC Coils

-	B	D	G	J
Voltage	12	24	48	110

DC Wide Range Coils

-	WD	WG	WI	WJ	WL	WN	WS
Voltage	24	48	72	110	125	220	250

Operating voltage limits with DC coils:

Standard = $0.8 \text{ to } 1.1 \times U_s$

Wide range = $0.7 \text{ to } 1.3 \times U_s$

- Order codes page B.9
- Auxiliary contacts blocks page B.10
- Accessories page B.12
- Technical data page B.29
- Dimensions page B.37



Auxiliary contactors

	Contacts acc. EN 50011			Control circuit: alternating current			Control circuit: direct current		
				Cat. no. ⁽¹⁾	Ref. no. see bottom	Pack.	Cat. no. ⁽¹⁾	Ref. no. see bottom	Pack.
	Screw terminal								
	40E	4	0	MCRA040AT	◆	5	MCRC040AT	◆	10
	31E	3	1	MCRA031AT	◆	5	MCRC031AT	◆	10
	22E	2	2	MCRA022AT	◆	5	MCRC022AT	◆	10
	13E	1	3	MCRA013AT	◆	5	MCRC013AT	◆	10
	04E	0	4	MCRA004AT	◆	5	MCRC004AT	◆	10
	Ring terminal								
	40E	4	0	MCRA040AR	◆	5	MCRC040AR	◆	10
	31E	3	1	MCRA031AR	◆	5	MCRC031AR	◆	10
	22E	2	2	MCRA022AR	◆	5	MCRC022AR	◆	10
	13E	1	3	MCRA013AR	◆	5	MCRC013AR	◆	10
	04E	0	4	MCRA004AR	◆	5	MCRC004AR	◆	10
	Terminal: faston 2 x 2.8 insulated⁽²⁾								
	40E	4	0	MCRA040AF	◆	5	MCRC040AF	◆	10
	31E	3	1	MCRA031AF	◆	5	MCRC031AF	◆	10
	22E	2	2	MCRA022AF	◆	5	MCRC022AF	◆	10
	13E	1	3	MCRA013AF	◆	5	MCRC013AF	◆	10
	04E	0	4	MCRA004AF	◆	5	MCRC004AF	◆	10
	Terminal: printed circuit								
	40E	4	0	MCRA040AI	◆	5	MCRC040AI	◆	10
	31E	3	1	MCRA031AI	◆	5	MCRC031AI	◆	10
	22E	2	2	MCRA022AI	◆	5	MCRC022AI	◆	10
	13E	1	3	MCRA013AI	◆	5	MCRC013AI	◆	10
	04E	0	4	MCRA004AI	◆	5	MCRC004AI	◆	10
	Spare coil			MB0A	◆	10	MB0C	◆	10

(1) To complete the catalogue number, replace the symbol ◆ by the code corresponding to the voltage and frequency of the control circuit. (see pag. B.8).
 (2) Terminal: - with wire 1.5mm²: Ie = 16A - with wire 1mm²: Ie = 10A
 Insulated terminal type B 2.8x0.8 with wire 1mm²: Ie = 8A to DIN 46247
 Faston terminal 1x6.3 on request, replace the letter F by H in the catalogue number

Auxiliary contactors interface

	Contacts acc. EN 50011			Control circuit: direct current 24V / 1.2W ⁽³⁾			Control circuit: direct current 24V / 2W ⁽⁴⁾		
				Operating limits from 19 to 30V (0.8-1.25xUs)			Operating limits from 17 to 30V (0.7-1.25xUs)		
			Cat. no.	Ref. no.	Pack.	Cat. no.	Ref. no.	Pack.	
	Screw terminal								
	40E	4	0	MCRI040ATD	100530	5	MCRK040ATD	100533	10
	31E	3	1	MCRI031ATD	100531	5	MCRK031ATD	100534	10
	22E	2	2	MCRI022ATD	100532	5	MCRK022ATD	100535	10
	Spare coil			MB0ID	100470	10	MB0KD	100471	10

(3) No possibility of adding instantaneous auxiliary blocks.
 (4) Facility to mount instantaneous auxiliary contact block of two contacts (MARN2...) or two instantaneous auxiliary contact blocks of one contact (MARL1...).

Order codes

Intro

A

B

C

D

E

F

G

H

I

X



Instantaneous auxiliary contacts blocks



Front mounting

Number of contacts	Combination with MCRA040AT ♦ (40E) according to EN 50011	Contacts acc. to EN 50005		Cat. no.	Ref. no.	Pack.
		Designation (block marking)				
Screw terminal						
2	60E	20	2 0	MARN220AT	100994	10
2	51E	11	1 1	MARN211AT	100993	10
2	42E	02	0 2	MARN202AT	100992	10
Ring terminal						
2	60E	20	2 0	MARN220AR	103349	10
2	51E	11	1 1	MARN211AR	103350	10
2	42E	02	0 2	MARN202AR	103351	10
Screw terminal						
4	80E	40	4 0	MARN440AT	100991	10
4	71E	31	3 1	MARN431AT	100990	10
4	62E	22	2 2	MARN422AT	100989	10
4	53E	13	1 3	MARN413AT	100988	10
4	44E	04	0 4	MARN404AT	100987	10
Ring terminal						
4	80E	40	4 0	MARN440AR	103352	10
4	71E	31	3 1	MARN431AR	103353	10
4	62E	22	2 2	MARN422AR	103354	10
4	53E	13	1 3	MARN413AR	103355	10
4	44E	04	0 4	MARN404AR	103300	10

Intro

A

B

C

D

E

F

G

H

I

X



Instantaneous auxiliary contacts blocks

	Number of contacts	Combination with MCRA040AT ♦ (40E) according to EN 50011	Contacts acc. to EN 50005		Cat. no.	Ref. no.	Pack.	
			Designation (block marking)	.3 .4				.1 .2
Front mounting	• One or two blocks to cover combinations of 5 or 6 contacts without increasing the height of the basic unit.							
	Screw terminal							
	1	50E	10	1	0	MARL110AT	100513	10
	1	-	01	0	1	MARL101AT	100514	10
	Ring terminal							
	1	50E	10	1	0	MARL110AR	103556	10
	1	-	01	0	1	MARL101AR	103557	10
	Terminal: Faston 2x2.8 insulated⁽¹⁾							
	1	50E	10	1	0	MARL110AF	100515	10
	1	-	01	0	1	MARL101AF	100516	10
	Terminal: printed circuit							
	1	50E	10	1	0	MARL110AI	100517	10
	1	-	01	0	1	MARL101AI	100518	10
	• One or two additional blocks, when 9 or 10 contacts are required (combination possible with the front mounting block) • One or two additional blocks on both sides, to cover up to 8 contacts (combination only possible with lateral blocks)							
	Screw terminal							
	1	50E	10	1	0	MARL110ATS	100519	10
	1	-	01	0	1	MARL101ATS	100520	10
	Ring terminal							
	1	50E	10	1	0	MARL110ARS	103299	10
	1	-	01	0	1	MARL101ARS	103298	10
	Terminal: Faston 2x2.8 insulated⁽¹⁾							
	1	50E	10	1	0	MARL110AFS	100521	10
	1	-	01	0	1	MARL101AFS	100522	10
	Terminal: printed circuit							
1	50E	10	1	0	MARL110AIS	100523	10	
1	-	01	0	1	MARL101AIS	100524	10	

(1) Terminal with wire 1mm²: Ie = 10A
Insulated terminal type B 2.8x0.8 with wire 1mm²: Ie = 8A

Order codes

Intro

A

B

C

D

E

F

G





H

I

X



Accessories

	For use with	Time	Function	Ue	Cat. no.	Ref. no.	Pack.	
	Electronic timer block	Lateral or front fixing on the contactor						
		MCR, MC_ ...	0.5 - 60 sec.	Delay ON	24 to 250V AC/DC	MREBC10AC2	100541	10
		MCR, MC_ ...	0.2 - 24 sec.	Delay ON	24 to 250V AC/DC	MREBC20AC2	100542	10
	Timer fitment	For fixing onto 35mm DIN-rail (EN 5022)						
		MREBC...				MVB0R	100543	10
	Voltage suppressor block	Connection and (plug-in) fixing onto front of the contactor						
		MCRA, MC_ ...	RC	AC	12 to 60V 50/60Hz	MP0AAE1	100544	10
		MCRA, MC_ ...	RC	AC	72 to 250V 50/60Hz	MP0AAE2	100545	10
		MCRC, MC_ ...	Diode	DC	6 to 250V DC	MP0CAE3	100546	10
		MCRC, MC_ ...	Varistor	AC/DC	24-48V	MP0DAE4	100536	10
		MCRC, MC_ ...	Varistor	AC/DC	50-127V	MP0DAE5	204848	10
		MCRC, MC_ ...	Varistor	AC/DC	130-250V	MP0DAE6	204849	10
	Mechanical interlock	Kit comprising mechanical interlock and contactor jointing parts						
		MCR, MC_ ...				MMH0	100547	10
	Identification	For use with			Cat. no.	Ref. no.	Pack.	
		MCR, MC_ ...	Sheets of labels (10 sheets of 260 labels each)		EAT 260	100547	10	
		MCR, MC_ ...	Labelling plate base. Plug-in labelling plate bases (50 pieces in one pack)		SPR	100549	10	

Everything is under control

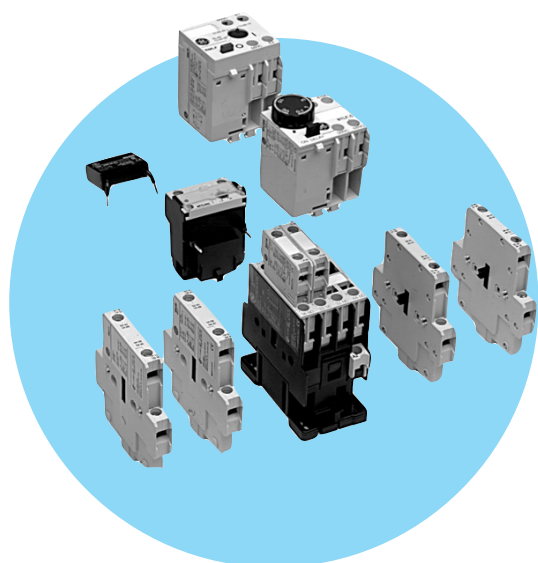

Auxiliary contactors *I_{th}* = 20A

- Control circuit: Alternating current up to 690V
Direct current up to 440V
- Terminal numbering in accordance with EN 50005 and EN 50011
- Fixing system for rapid and simple mounting onto standard 35mm DIN-rail (EN 50022-35)
- Terminals protected against accidental contact in accordance with VDE 0106 T.100, VBG4
- Ring terminal versions
- Three coil terminals
- Facility to mount side and/or front instantaneous contact blocks, timed auxiliary contacts, mechanical latch, voltage suppressor blocks and interface modules.
- Degree of protection IP20 (EN 60529)

Standards

IEC/EN 60947-5-1	BS 4794
IEC/EN 60947-1	CENELEC HD410
EN 90947	CENELEC HD420
EN 60947	NFC 63-110
EN 50005	NFC 63-140
EN 50011	CSA C22.2/14
UL 508	VDE 0660/102
NEMA ICS 1	

General data

Maximum number of contacts (RL...)	4
Rated thermal current (I_{th}) θ ≤ 55°	(A) 20
Rated operational voltage (U_e)	(V) 690
Insulation voltage (U_i)	(V) 1000

Utilisation category:

AC-15	V	120	230/220	400/380	440/415	500	690/660
A	10	10	6	5	4	2	

DC-13	V	24	48	110	220	440
A	6	4	2	0.7	0.35	

Approvals/Marking



Lloyd's Register



Bureau Veritas



RINA

Standard voltages

AC Coils

-	1	2	9	J	K	L	6	7	N	U	Y
50/60Hz	24	42	48				220-230	240			
50 Hz				110-115	127					380-400	500
60Hz				110-120		208			277	440	600

DC Coils

-	B	D	G	H	J	K	N	T
Voltage	12	24	48	60	110	120-125	220	250

DC Wide Range Coils

-	WD	WE	WG	WI	WJ	WN
Voltage	24	33	48	72	110	220

- Order codes ● page B.15
- Accessories ● page B.16
- Technical data ● page B.39
- Dimensions ● page B.45



Accessories

	Number of contacts	Contacts				Cat. no.	Ref. no.	Pack.
		.3 .4	.1 .2	.7 .8	.5 .6			
	Mechanical	-	-	-	-	BELA	104723	5
	Mechanical / electrical	2	0	2	-	BELA02	104724	5

	Mechanical latch blocks	Frontal mounted to the contactor	RL4RA..., RL4RD...	RMLF	see bottom	20
---	-------------------------	----------------------------------	--------------------	------	------------	----

(1) To complete the catalogue number, replace the symbol © by the code corresponding to the voltage and frequency of the control circuit.

	D	G	HC	J	N	U	Y
50Hz	24, 32	42, 48		110, 115, 120, 127	220, 230, 240	380, 400, 415, 440, 480	500, 660/690
60Hz	24, 32	48, 60		110, 115, 120, 127	208, 220, 240, 277	380, 400, 415, 440, 480	600
DC	24, 32, 36	42, 48	60, 72	110, 120, 125	220, 230, 240, 250	440	

	For use with	Type	Control circ.	Ue	Cat. no.	Ref. no.	Pack.
	Transient voltage suppressor block	Directly connected parallel to the coil terminals, allows simultaneous use with auxiliary contact blocks.					
	RL4RA...	R/C	AC	12V ... 48V	BSLR2G	104713	10
	RL4RA...	R/C	AC	50V ... 127V	BSLR2K	104714	10
	RL4RA...	R/C	AC	130V ... 250V	BSLR2R	104715	10
	RL4RD...	Diode	DC		BSLDZ	104719	10
	RL4RA..., RL4RD...	Varistor	AC / DC	24V ... 48V	BSLV3G	104720	10
	RL4RA..., RL4RD...	Varistor	AC / DC	50V ... 127V	BSLV3K	104721	10
	RL4RA..., RL4RD...	Varistor	AC / DC	130V ... 250V	BSLV3R	104722	10
RL4RA..., RL4RD...	Varistor	AC / DC	277V ... 500V	BSLV3U	110836	10	

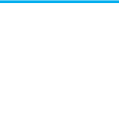
	For use with		Cat. no.	Ref. no.	Pack.
	Identification	RL4RA..., RL4RD...	EAT 260	100548	1
		RL4RA..., RL4RD...	SPR	100549	1

	For use with	Control circuit	Function	Time	Cat. no.	Ref. no.	Pack.
	Electronic timer module	Directly connected parallel to the coil terminals, allows simultaneous use with auxiliary contact blocks.					
	RL4...	24-250V AC/DC	Delayed ON	0.1 - 2 sec.	BETL02C	113602	5
	RL4...	24-250V AC/DC	Delayed ON	1.5 - 45 sec.	BETL45C	113603	5
	RL4...	24-250V AC/DC	Delayed OFF	0.1 - 2 sec.	BETL02D	113604	5
	RL4...	24-250V AC/DC	Delayed OFF	1.5 - 45 sec.	BETL45D	113605	5

Auxiliary contactors Ith = 20A

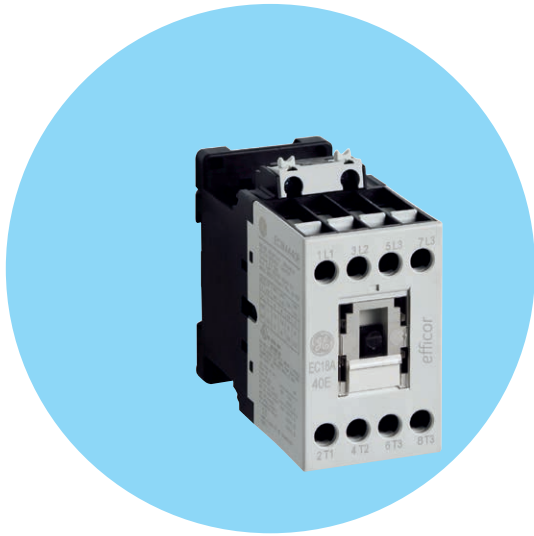

- Double cage clamp terminals
- Control circuit: Alternating current up to 690V, Direct current up to 440V
- Safe control circuit:
 - High fidelity auxiliary with four points of contact ensuring conductivity
 - Positive guided, mechanically linked contacts according to IEC 60947-5-1
- Wide temperature operation: -40°C to 55°C without derating
- Low noise, 32dBA... No humming noise
- Safer plastics: NF 16-101 and NF 16-102
- Closed design: Protection against pollution
- Terminal numbering in accordance with EN5005 and EN50011
- Fixing system for rapid and simple mounting onto standard 35mm DIN-rail
- Same accessories than Efficor contactor: Facility to mount side and/or front instantaneous contact blocks, timed auxiliary contacts, mechanical latch and voltage suppressor blocks.

Standards

IEC/EN 60947-5-1 ANSI/UL 60947-1
 IEC/EN 60947-1 ANSI/UL 60947-5-1
 EN 50005 VDE 0660/102
 EN 50011
 EN 45545-2
 EN50155

Approval/Marking



Catalog number configurator

Example: EC AC A 431 B 024 L

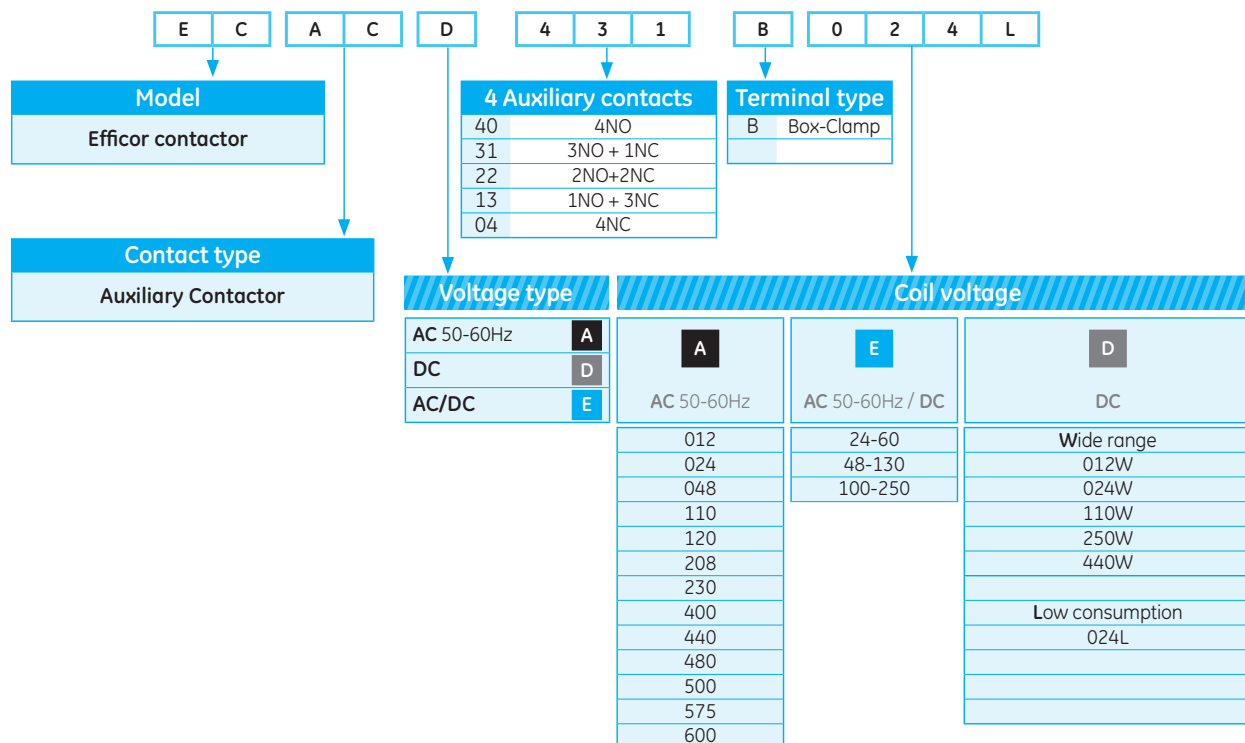

Order codes

Intro

A

B

C

D

E

F

G



H

I

X

Auxiliary contactors - Double box terminals - Ith 20A



Contacts		Control circuit					
NO  .3 .4	NC  .1 .2	AC			Voltage	Cat. no. ⁽¹⁾	Ref. no.
		Voltage	Cat. no.	Ref. no.			
4	0	12	ECACA440B012	268140	AC/DC		
4	0	24	ECACA440B024	268141	24-60	ECACE440B24-60	216419
4	0	48	ECACA440B048	268143	48-130	ECACE440B48-130	216420
4	0	110	ECACA440B110	268144	100-250	ECACE440B100-250	216421
4	0	120	ECACA440B120	268145			
4	0	208	ECACA440B208	268146		DC	
4	0	230	ECACA440B230	268147	12	ECACD440B012W	268210
4	0	240	ECACA440B240	268148	24	ECACD440B024W	268211
4	0	400	ECACA440B400	268149	110	ECACD440B110W	268216
4	0	440	ECACA440B440	268150	250	ECACD440B250W	268219
4	0	480	ECACA440B480	268151	440	ECACD440B440W	268220
4	0	500	ECACA440B500	268152			
4	0	600	ECACA440B600	268153	24	ECACD440B024L	268221
3	1	12	ECACA431B012	268154	AC/DC		
3	1	24	ECACA431B024	268155	24-60	ECACE431B24-60	216422
3	1	48	ECACA431B048	268157	48-130	ECACE431B48-130	216423
3	1	110	ECACA431B110	268158	100-250	ECACE431B100-250	216424
3	1	120	ECACA431B120	268159			
3	1	208	ECACA431B208	268160		DC	
3	1	230	ECACA431B230	268161	12	ECACD431B012W	268225
3	1	240	ECACA431B240	268162	24	ECACD431B024W	268226
3	1	400	ECACA431B400	268163	110	ECACD431B110W	268231
3	1	440	ECACA431B440	268164	250	ECACD431B250W	268234
3	1	480	ECACA431B480	268165	440	ECACD431B440W	268235
3	1	500	ECACA431B500	268166			
3	1	600	ECACA431B600	268167	24	ECACD431B024L	268236
2	2	12	ECACA422B012	268168	AC/DC		
2	2	24	ECACA422B024	268169	24-60	ECACE422B24-60	216425
2	2	48	ECACA422B048	268171	48-130	ECACE422B48-130	216426
2	2	110	ECACA422B110	268172	100-250	ECACE422B100-250	216427
2	2	120	ECACA422B120	268173			
2	2	208	ECACA422B208	268174		DC	
2	2	230	ECACA422B230	268175	12	ECACD422B012W	268240
2	2	240	ECACA422B240	268176	24	ECACD422B024W	268241
2	2	400	ECACA422B400	268177	110	ECACD422B110W	268246
2	2	440	ECACA422B440	268178	250	ECACD422B250W	268249
2	2	480	ECACA422B480	268179	440	ECACD422B440W	268250
2	2	500	ECACA422B500	268180			
2	2	600	ECACA422B600	268181	24	ECACD422B024L	268251
1	3	12	ECACA413B012	268182	AC/DC		
1	3	24	ECACA413B024	268183	24-60	ECACE413B24-60	216428
1	3	48	ECACA413B048	268185	48-130	ECACE413B48-130	216429
1	3	110	ECACA413B110	268186	100-250	ECACE413B100-250	216430
1	3	120	ECACA413B120	268187			
1	3	208	ECACA413B208	268188		DC	
1	3	230	ECACA413B230	268189	12	ECACD413B012W	268400
1	3	240	ECACA413B240	268190	24	ECACD413B024W	268401
1	3	400	ECACA413B400	268191	110	ECACD413B110W	268406
1	3	440	ECACA413B440	268192	250	ECACD413B250W	268409
1	3	480	ECACA413B480	268193	440	ECACD413B440W	268410
1	3	500	ECACA413B500	268194			
1	3	600	ECACA413B600	268195	24	ECACD413B024L	268411
0	4	12	ECACA404B012	268196	AC/DC		
0	4	24	ECACA404B024	268197	24-60	ECACE404B24-60	216431
0	4	48	ECACA404B048	268199	48-130	ECACE404B48-130	216432
0	4	110	ECACA404B110	268200	100-250	ECACE404B100-250	216433
0	4	120	ECACA404B120	268201			
0	4	208	ECACA404B208	268202		DC	
0	4	230	ECACA404B230	268203	12	ECACD404B012W	268270
0	4	240	ECACA404B240	268204	24	ECACD404B024W	268271
0	4	400	ECACA404B400	268205	110	ECACD404B110W	268276
0	4	440	ECACA404B440	268206	250	ECACD404B250W	268279
0	4	480	ECACA404B480	268207	440	ECACD404B440W	268280
0	4	500	ECACA404B500	268208			
0	4	600	ECACA404B600	268209			

(1) End character: W = Wide voltage (0.7-1.25xUn) and built-in diode. L = Low consumption.

Technical data, terminal numbering and dimensions are available in chapter A under Effcor.



Spare coils for contactors and auxiliary contactors - Box clamp terminals



Voltage	Use for	Cat. no.	Ref. no.	Pack
12V AC	EC09A...EC18A, ECACA...B	ECCS1A012S	268687	5
24V AC	EC09A...EC18A, ECACA...B	ECCS1A024S	268688	5
48V AC	EC09A...EC18A, ECACA...B	ECCS1A048S	268690	5
110V AC	EC09A...EC18A, ECACA...B	ECCS1A110S	268691	5
120V AC	EC09A...EC18A, ECACA...B	ECCS1A120S	268692	5
208V AC	EC09A...EC18A, ECACA...B	ECCS1A208S	268693	5
230V AC	EC09A...EC18A, ECACA...B	ECCS1A230S	268694	5
240V AC	EC09A...EC18A, ECACA...B	ECCS1A240S	268695	5
400V AC	EC09A...EC18A, ECACA...B	ECCS1A400S	268696	5
440V AC	EC09A...EC18A, ECACA...B	ECCS1A440S	268697	5
480V AC	EC09A...EC18A, ECACA...B	ECCS1A480S	268698	5
500V AC	EC09A...EC18A, ECACA...B	ECCS1A500S	268699	5
575V AC	EC09A...EC18A, ECACA...B	ECCS1A575S	268984	5
600V AC	EC09A...EC18A, ECACA...B	ECCS1A600S	268700	5

Order codes

Intro

A

B

C

D

E

F

G

H

I

X

Technical data

Sockets for miniature plug-in relays

		PRCG-ES15/2N	PRCG-ES15/3N	PRCG-ES15/4N
		Screw terminals two levels	Screw terminals two levels	Screw terminals two levels
<i>Specifications</i>				
Nominal load	(A)	12 (300V)	10 (300V)	10 (300V)
<i>Dielectric strength</i>				
Adjacent screws	(kV)	3	3	3
Screws - rail	(kV)	3	3	3
<i>Terminals</i>				
Type		Screw M4, Pozidriv	Screw M4, Pozidriv	Screw M3, Pozidriv
Max. torque	(Nm)	0.7	0.7	0.7
<i>Protection category</i>				
Protection category		IP20	IP20	IP20
<i>Capacity</i>				
Solid wire	(mm ²)	2x2.5	2x2.5	2x2.5
Flexible wire		22-14 AWG	22-14 AWG	22-14 AWG
Ambient temperature	(°C)	-40 ... +70	-40 ... +70	-40 ... +70

Sockets for 8-11 pin standard plug-in relays

		PRCZ8	PRCG08	PRCZ11	PRCG11
		Screw terminals One level	8 pin Solder terminal socket	Screw terminals One level	11 pin Solder terminal socket
<i>Specifications</i>					
Nominal load	(A)	10 (250V)	10 (250V)	10 (250V)	10 (250V)
<i>Dielectric strength</i>					
Adjacent screws	(kV)	2.5	2.5	2.5	2.5
Screws - rail	(kV)	3		3	
<i>Terminals</i>					
Type		Screw M3, Pozidriv	Hard brass tin-plated terminals	Screw M3, Pozidriv	Hard brass tin-plated terminals
Max. torque	(Nm)	0.7		0.7	
<i>Protection category</i>					
Protection category		IP20		IP20	
<i>Capacity</i>					
Solid wire	(mm ²)	2x2.5		2x2.5	
Flexible wire		22-14 AWG		22-14 AWG	
Ambient temperature	(°C)	-40 ... +70		-40 ... +70	

Sockets for miniature P.C.B. relays

		PRCGZ80
		Screw terminals Two levels
<i>Specifications</i>		
Nominal load	(A)	12 (300V)
<i>Dielectric strength</i>		
Adjacent screws	(kV)	3
Screws - rail	(kV)	3
<i>Terminals</i>		
Type		Screw M4, Pozidriv
Max. torque	(Nm)	0.7
<i>Protection category</i>		
Protection category		IP20
<i>Capacity</i>		
Solid wire	(mm ²)	2x2.5
Flexible wire		22-14 AWG
Ambient temperature	(°C)	-40 ... +70

Miniature plug-in relays

		PRC4M20...	PRC4M30...	PRC4M40...
		2 pole	3 pole	4 pole
Contacts				
Number of contacts		2 changeover	3 changeover	4 changeover
Standard material		AgNi	AgNi	AgNi
Optional material		AgNi/Au 5μ	AgNi/Au 5μ	AgNi/Au 5μ
Voltage				
Max. switching voltage	AC/DC (poll. 3)	250V	250V	250V
	AC (poll. 2)	400V	400V	400V
Min. switching voltage	AC/DC	5V	5V	5V
Current				
Rated load	AC1 (A)	12 (250V)	10 (250V AC)	6 (250V AC)
	AC15 (A)	3 (120V) / 1.5 (240V)	3 (120V) / 1.5 (240V)	1.5 (120V) / 0.75 (240V)
	DC1 (A)	10 (24V)	10 (24V)	6 (24V)
	DC13 (A)	0.22 (120V) / 0.1 (250V)	0.22 (120V) / 0.1 (250V)	0.22 (120V) / 0.1 (250V)
Min. switching current	(mA)	5	5	5
Max. inrush current	(A)	24	20	12
Rated current	(A)	12	10	6
Max. breaking capacity	(VA)	3000	2500	1500
Resistance	(mΩ)	≤100	≤100	≤100
		(100mA, 24V)	(100mA, 24V)	(100mA, 24V)
Max. operating frequency				
At rated load	cycles/hour	1200	1200	1200
No load	cycles/hour	18000	18000	18000
Coil				
Rated voltage	AC 50/60Hz (V)	6 ... 240	6 ... 240	6 ... 240
	DC (V)	5 ... 220	5 ... 220	5 ... 220
Must release time	AC (V)	≥0.2 Un	≥0.2 Un	≥0.2 Un
	DC (V)	≥0.1 Un	≥0.1 Un	≥0.1 Un
Operating range of supply voltage		Table 1, 2	Table 1, 2	Table 1, 2
Rated power consumption	AC 50Hz (VA)	1.5	1.6	1.6
	60Hz (VA)	1.3	1.3	1.3
	DC (W)	0.9	0.9	0.9
	AC/DC (W)	-	-	-
Insulation according to EN 60664-1				
Insulation rated voltage	(VAC)	250	250	250
Rated surge voltage	(V)	4000 1.2/50 μs	4000 1.2/50 μs	2500 1.2/50 μs
Overvoltage category		III	III	II
Insulation pollution degree		2	2	2
Dielectric strength	Coil-Contact (VAC)	2500	2500	2500
	Contact-Contact (VAC)	1500	1500	1500
	Pole-Pole (VAC)	2500	2500	2000
Contact coil distance	Clearance (mm)	≥ 2.5	≥ 2.5	≥ 1.6
	Creepage (mm)	≥ 4	≥ 4	≥ 3.2
General data				
Operating time (typical value)	AC (ms)	10	10	10
	DC (ms)	13	13	13
Release time (typical value)	AC (ms)	8	8	8
	DC (ms)	3	3	3
Electrical life	Resistive	≥ 10 ⁵	≥ 10 ⁵	≥ 10 ⁵
	Cos φ	(12A, 250V AC)	(10A, 250V AC)	(6A, 250V AC)
		See curves	See curves	See curves
Mechanical life (cycles)		≥ 10 ⁷	≥ 10 ⁷	≥ x10 ⁷
Ambient temperature	Storage (°C)	-40 ... +85	-40 ... +85	-40 ... +85
	Operating AC (°C)	-40 ... +55	-40 ... +55	-40 ... +55
	DC (°C)	-40 ... +70	-40 ... +70	-40 ... +70
Cover protection category		IP40	IP40	IP40
Shock resistance	(G)	10	10	10
Vibration resistance	(G)	5	5	5
		(for 10..150Hz)	(for 10..150Hz)	(for 10..150Hz)

Table 1. Coil data DC version

Rated voltage V DC	Coil resistance Ω	Coil operating range V DC	
		Min. (at 20°C)	Max. (at 55°C)
12	160	9.6	13.2
24	640	19.2	26.4
48	2600	38.4	52.8
110	13600	88	121
220	54000	176	242

Table 2. Coil data AC 50/60Hz version

Rated voltage V AC	Coil resistance Ω	Coil operating range V AC	
		Min. (at 20°C)	Max. (at 55°C)
12	39	9.6	13.2
24	158	19.2	26.4
48	640	38.4	52.8
132	3770	96	120
230	16100	184	253

Series PRC

Miniature 2 pole plug-in relays

Electrical life at AC resistive load

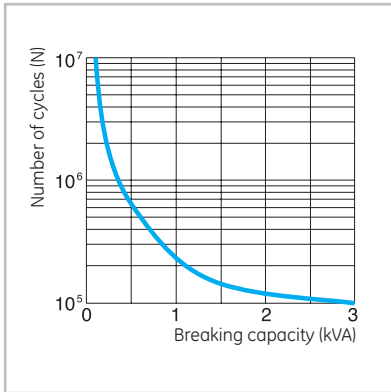

Electrical life reduction factor at AC inductive load

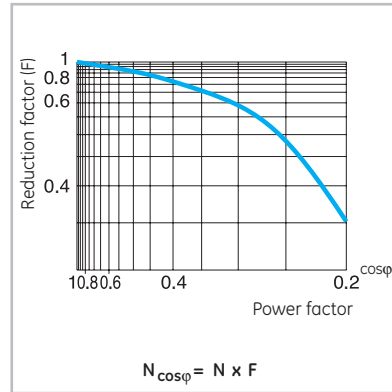

Max. DC resistive load breaking capacity

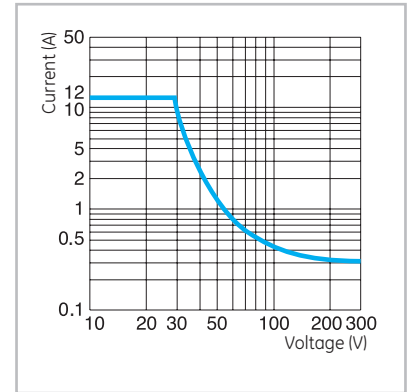

Miniature 3 pole plug-in relays

Electrical life at AC resistive load

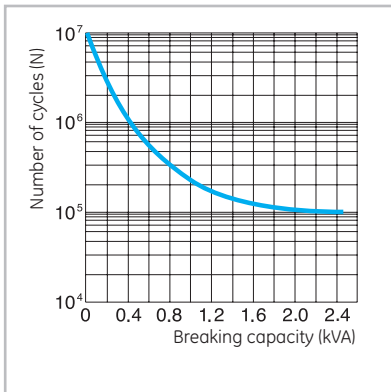

Electrical life reduction factor at AC inductive load

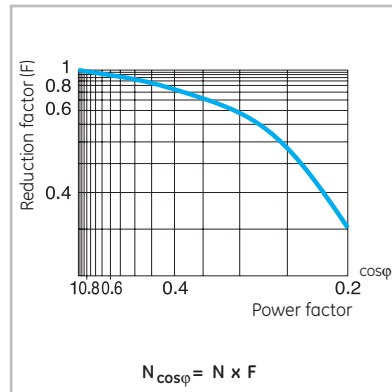

Max. DC load breaking capacity

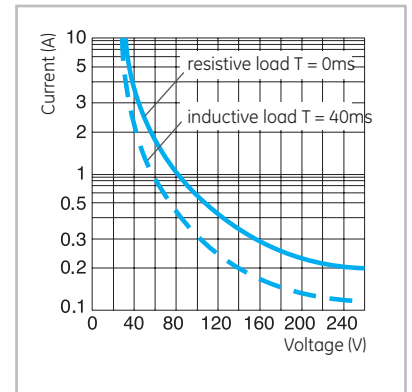

Miniature 4 pole plug-in relays

Electrical life at AC resistive load

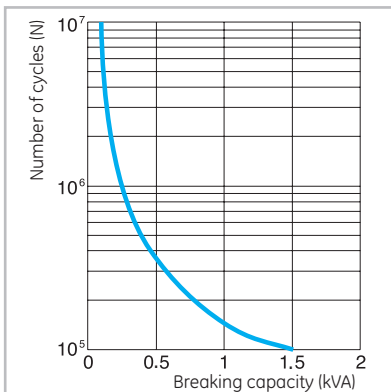

Electrical life reduction factor at AC inductive load

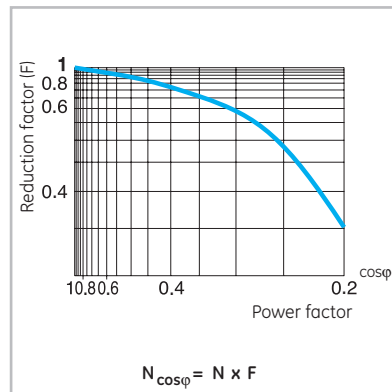

Max. DC resistive load breaking capacity

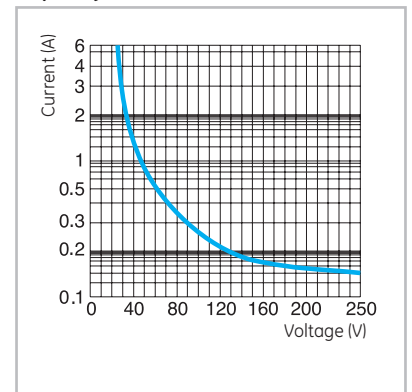

Standard 8-11 pin plug-in relays

		PRC2P20...	PRC3P30...
		Standard 8-pin	Standard 11-pin
Contacts			
Number of contacts		2 changeover	3 changeover
Standard material		AgNi	AgNi
Optional material		AgNi/Au 5μ	AgNi/Au 5μ
Voltage			
Max switching voltage	AC/DC (poll. 3)	250V	250V
	AC (poll. 2)	400V	400V
Min switching voltage	AC/DC	10V (AgNi) 5V (AgNi/Au 5μ)	10V (AgNi) 5V (AgNi/Au 5μ)
Current			
Rated load	AC1 (A)	10 (250V)	10 (250V AC)
	AC15 (A)	3 (120V) / 1.5 (240V)	3 (120V) / 1.5 (240V)
	DC1 (A)	10 (24V)	10 (24V)
	DC13 (A)	0.22 (120V) / 0.1 (250V)	0.22 (120V) / 0.1 (250V)
Min. switching current	(mA)	5	5
Max. inrush current	(A)	30	30
Rated current	(A)	10	10
Max. breaking capacity	(VA)	2500	2500
Resistance	(mΩ)	H100 (100mA, 24V)	H100 (100mA, 24V)
Max. operating frequency			
At rated load	cycles/hour	1200	1200
No load	cycles/hour	12000	12000
Coil			
Rated voltage	AC 50/60Hz (V)	6 ... 240	6 ... 240
	DC (V)	6 ... 220	6 ... 220
Must release time	AC	≥0.15 Un	≥0.15 Un
voltage	DC	≥0.1 Un	≥0.1 Un
Operating range of supply voltage		Table 1, 2	Table 1, 2
Rated power	AC 50Hz (VA)	2.7	2.7
consumption	60Hz (VA)	2.5	2.5
	DC (W)	1.5	1.5
	AC/DC (W)	-	-
Insulation according to EN 60664-1			
Insulation rated voltage	(VAC)	250	250
Rated surge voltage	(V)	4000 1.2/50 μs	4000 1.2/50 μs
Overvoltage category		III	III
Insulation pollution degree		3	3
Dielectric strength	Coil-Contact (VAC)	2500	2500
	Contact-Contact (VAC)	1500	1500
	Pole-Pole (VAC)	2000	2000
Distance	Clearance (mm)	≥ 3	≥ 3
contact coil	Creepage (mm)	≥ 4.2	≥ 4.2
General			
Operating time	AC (ms)	12	12
(typical value)	DC (ms)	12	12
Release time	AC (ms)	10	10
(typical value)	DC (ms)	7	7
Electrical life	Resistive	≥ 2 × 10 ⁵ (10A, 250V AC)	≥ 2 × 10 ⁵ (10A, 250V AC)
	Cos φ	See curves	See curves
Mechanical life (cycles)		≥ 2 × 10 ⁷	≥ 2 × 10 ⁷
Ambient temperature	Storage (°C)	-40 ... +85	-40 ... +85
	Operating AC (°C)	-40 ... +55	-40 ... +55
	DC (°C)	-40 ... +70	-40 ... +70
Cover protection category		IP40	IP40
Shock resistance	(G)	10	10
Vibration resistance	(G)	5	5

Table 1. Coil data DC version

Rated voltage V DC	Coil resistance Ω	Coil operating range V DC	
		Min. (at 20°C)	Max. (at 55°C)
12	110	9.6	13.2
24	430	19.2	26.4
48	1750	38.4	52.8
110	9200	88	121
220	37000	176	242

Table 2. Coil data AC 50/60Hz version

Rated voltage V AC	Coil resistance Ω	Coil operating range V AC	
		Min. (at 20°C)	Max. (at 55°C)
12	18.5	9.6	13.2
24	75	19.2	26.4
48	305	38.4	52.8
120	1910	96	132
230	7080	184	253

Electrical life at AC resistive load

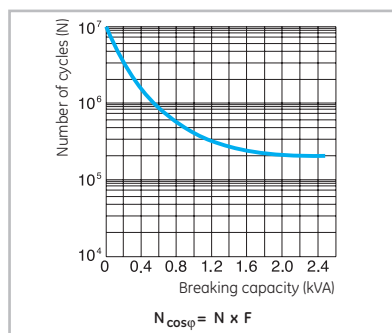

Electrical life reduction factor at AC inductive load

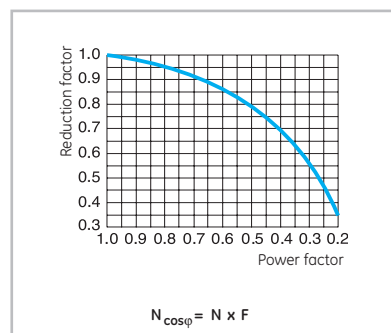

Max. DC load breaking capacity

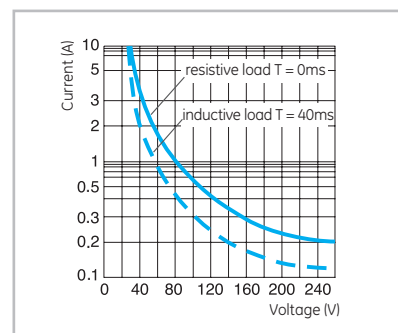

Interface plug-in relays

			PRC1S13...	
Contacts				
Number of contacts			1 changeover	
Standard material			AgSnO ₂	
Optional material				
Voltage				
Max switching voltage	AC/DC (poll. 3)		AC 250V / DC 150V	
	AC (poll. 2)		AC 400V / DC 300V	
Min switching voltage	AC/DC		12V	
Current				
Rated load	AC1	(A)	6 (250V)	
	DC1	(A)	6 (30V)	
Min. switching current		(mA)	10	
Max. inrush current (A)			15	
Rated current		(A)	6	
Max. breaking capacity		(VA)	1500V	
Resistance		(mΩ)	≤100	
			(100mA, 24V)	
Max. operating frequency				
At rated load			360 cycles/hour	
No load			72000 cycles/hour	
Coil				
Rated voltage	AC/DC	(V)	24, 230	
	AC 50/60Hz	(V)	230	
	DC	(V)	12, 24	
Must release time	AC		≥0.2 Un	
voltage	DC		≥0.1 Un	
Operating range of supply voltage			See Table 1	
Rated power consumption	AC 50Hz	(VA)	0.6..1.9	
	60Hz	(VA)	-	
	DC	(W)	0.33	
	AC/DC	(W)	0.48 (at 24V), 1.8 (at 230V)	
Insulation according to EN 60664-1				
Insulation category			250	
Rated surge voltage		(V)	4000 1.2/50 μs	
Overtoltage category			III	
Insulation pollution degree			3	
Insulation rated voltage		(VAC)	400	
Dielectric strength	Coil-Contact	(VAC)	4000	
	Contact-Contact	(VAC)	1000	
	Pole-Pole	(VAC)	-	
Distance	Clearance	mm	≥ 8	
contact coil	Creepage	mm	≥ 8	
General				
Operating time	AC	(ms)	8	
(typical value)	DC	(ms)	6	
Release time	AC	(ms)	15	
(typical value)	DC	(ms)	8	
Electrical life	Resistive			
	Cos φ			
Mechanical life (cycles)			20 x 10 ⁶	
Ambient temperature	Storage	(°C)	-40 ... +70	
	Operating	AC	(°C)	-20 ... +55
		DC	(°C)	-20 ... +55
Cover protection category			IP20	
Shock resistance		(G)	10	
Vibration resistance		(G)	0.062" DA	
			(10 ... 55Hz)	

Table 1. Interface relay

Rated voltage V		Coil operating range V DC	
		Min.	Max.
12	DC	9	17
24	DC	17	30
24	AC/DC	18	30
230	AC	80	250
230	AC/DC	185	250

Interface relay for PLC systems

PRC1T10...		
Contacts		
Number of contacts		1 changeover
Standard material		AgNi
Optional material		
Voltage		
Max. switching voltage	AC/DC	AC 400V / DC 300V
Min. switching voltage	AC/DC	5V
Current		
Rated load	AC1	(A) 16 (250V AC)
	DC1	(A) 16 (24V DC)
Min. switching current	(mA)	5
Max. inrush current	(A)	30
Rated current	(A)	16
Max. breaking capacity	(VA)	4000
Min. breaking capacity	(W)	0.3
Resistance	(mΩ)	≤100 (at 1A, 24V)
Max. operating frequency		
At rated load		600 cycles/hour
No load		72000 cycles/hour
Coil		
Rated voltage	AC 50/60Hz	(V) 24, 120, 230
	DC	(V) 12, 24, 110
Must release time	AC	≥0.15 Un
voltage	DC	≥0.1 Un
Operating range of supply voltage		See Table 1, 2
Rated power	AC	(VA) 0.75
consumption	DC	(W) 0.4
Insulation		
Insulation category		C250
Insulation rated voltage	(VAC)	400
Dielectric strength	Coil-Contact	(VAC) 5000
	Contact-Contact	(VAC) 1000
	Pole-Pole	(VAC) -
Distance	Clearance	mm ≥ 10
contact coil	Creepage	mm ≥ 10
General		
Operating time	AC	(ms) 7
(typical value)	DC	(ms) 7
Release time	AC	(ms) 5
(typical value)	DC	(ms) 3
Electrical life	Resistive	(s) ≥ 0.7 × 10 ⁵ (at 16A, 250VAC)
	Cos φ	See curves
	L/R = 40ms	≥ 10 ⁵ (at 0.12A, 220VDC)
Mechanical life (cycles)		3 × 10 ⁷
Ambient	Storage	(°C) -40 ... +70
temperature	Operating	(°C) -40 ... +70
Cover protection category		IP40
Shock resistance	(G)	30
Vibration resistance	(G)	10 (for 10 ... 150Hz)

Table 1. Coil data DC version

Rated voltage V DC	Coil resistance Ω (±10% at 20°C)	Coil operating range V DC	
		U Min.	U Max.
12	360	8.4	30.6
24	1440	16.8	61.2
110	25200	77	280

Table 2. Coil data AC 50/60Hz version

Rated voltage V AC	Coil resistance Ω (±10% at 20°C)	Coil operating range V AC	
		U Min.	U Max.
24	400	19.2	28.8
120	10200	96	144
230	38500	184	276

Electrical life at AC resistive load

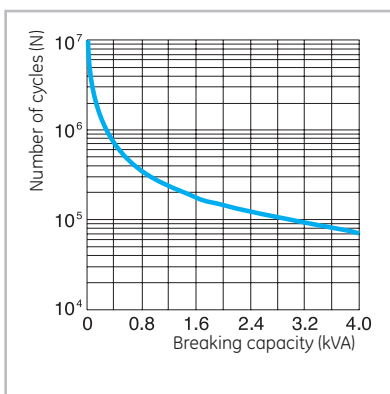

Electrical life reduction factor at AC inductive load

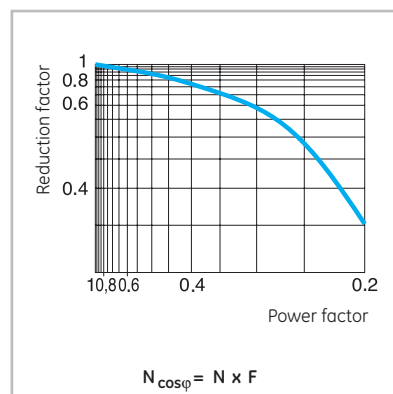

Max. DC load breaking capacity

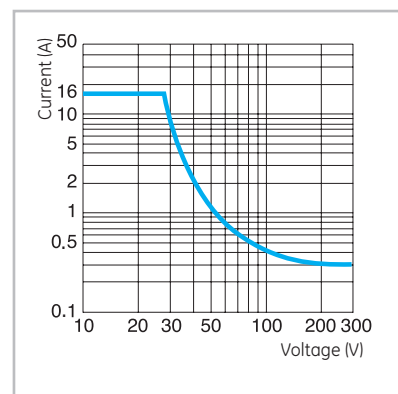

Interface relay for PLC systems

PRC1T20...		
Contacts		
Number of contacts		2 changeover
Standard material		AgNi
Optional material		
Voltage		
Max. switching voltage	AC/DC	AC 400V / DC 300V
Min. switching voltage	AC/DC	5V
Current		
Rated load	AC1	(A) 8 (250V AC)
	DC1	(A) 8 (24V DC)
Min. switching current	(mA)	5
Max. inrush current	(A)	15
Rated current	(A)	8
Max. breaking capacity	(VA)	2000
Min. breaking capacity	(W)	0.3
Resistance	(mΩ)	≤100 (at 1A, 24V)
Max. operating frequency		
At rated load		600 cycles/hour
No load		72000 cycles/hour
Coil		
Rated voltage	AC 50/60Hz	(V) 24, 230
	DC	(V) 12, 24
Must release time	AC	≥0.15 Un
	DC	≥0.1 Un
Operating range of supply voltage		See Table 1, 2
Rated power	AC	(VA) 0.75
consumption	DC	(W) 0.4
Insulation		
Insulation category		C250
Insulation rated voltage	(VAC)	400
Dielectric strength	Coil-Contact	(VAC) 5000
	Contact-Contact	(VAC) 1000
	Pole-Pole	(VAC) -
Distance	Clearance	mm ≥ 10
	Creepage	mm ≥ 10
General		
Operating time	AC	(ms) 7
(typical value)	DC	(ms) 7
Release time	AC	(ms) 5
(typical value)	DC	(ms) 3
Electrical life	Resistive	(s) ≥ 0.7 × 10 ⁵ (at 8A, 250VAC)
	Cos φ	See curves
	L/R = 40ms	≥ 10 ⁵ (at 0.12A, 220VDC)
Mechanical life (cycles)		3 × 10 ⁷
Ambient temperature	Storage	(°C) -40 ... +70
	Operating	(°C) -40 ... +70
Cover protection category		IP40
Shock resistance	(G)	20
Vibration resistance	(G)	10 (for 10 ... 150Hz)

Table 1. Coil data DC version

Rated voltage V DC	Coil resistance (±10%) at 20°C Ω	Coil operating range V DC	
		U Min.	U Max.
12	360	8.4	30.6
24	1440	16.8	61.2
110	25200	77	280

Table 2. Coil data AC 50/60Hz version

Rated voltage V AC	Coil resistance (±10%) at 20°C Ω	Coil operating range V AC	
		U Min.	U Max.
24	400	19.2	28.8
120	10200	96	144
230	38500	184	276

Electrical life at AC resistive load

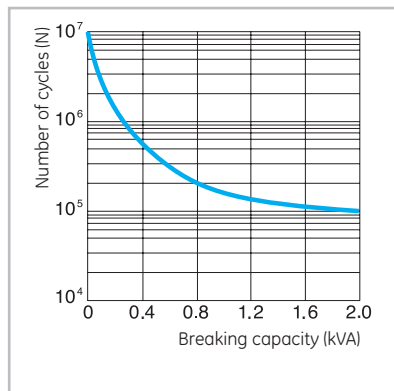

Electrical life reduction factor at AC inductive load

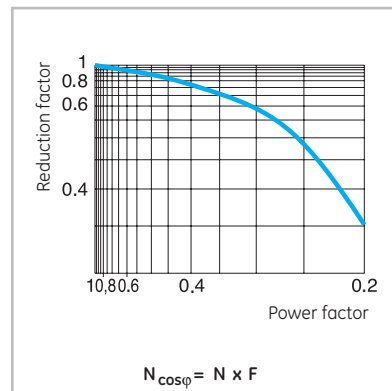

Max. DC load breaking capacity

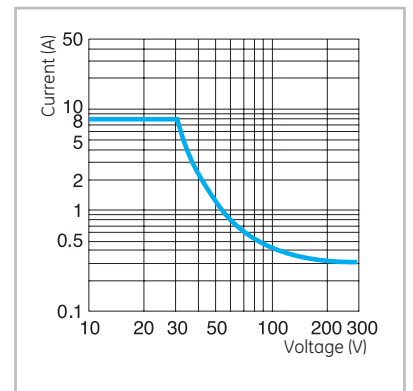

Dimensional drawings

Miniature

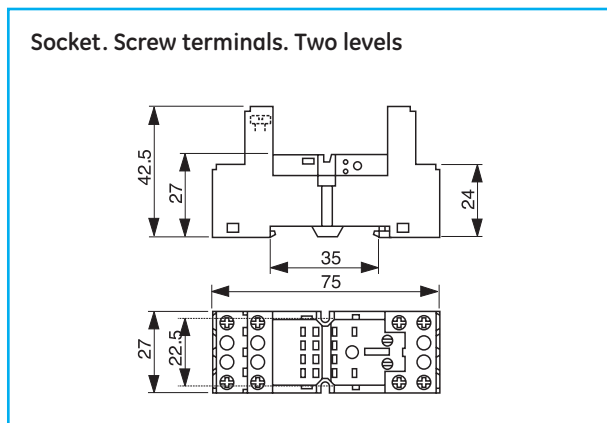
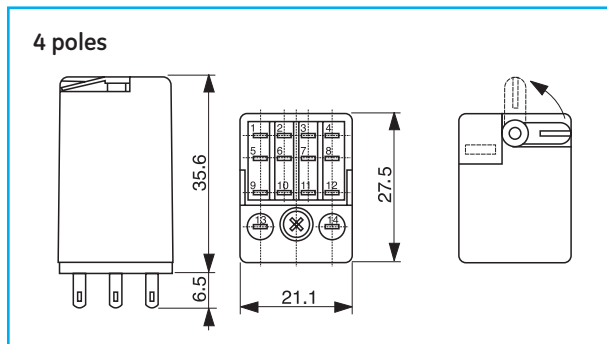
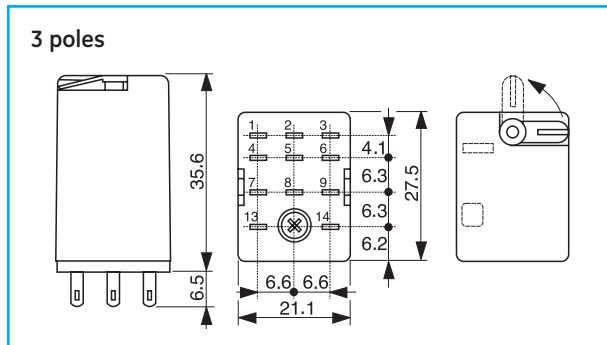
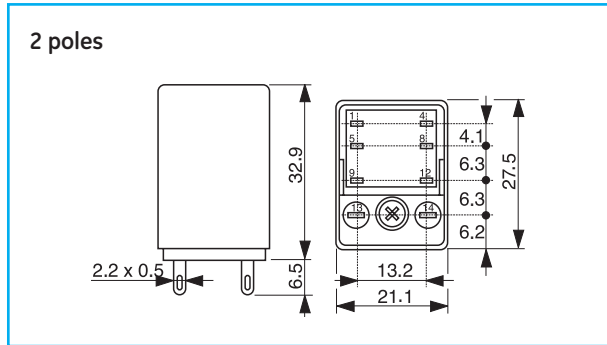

Standard 8-11 pin

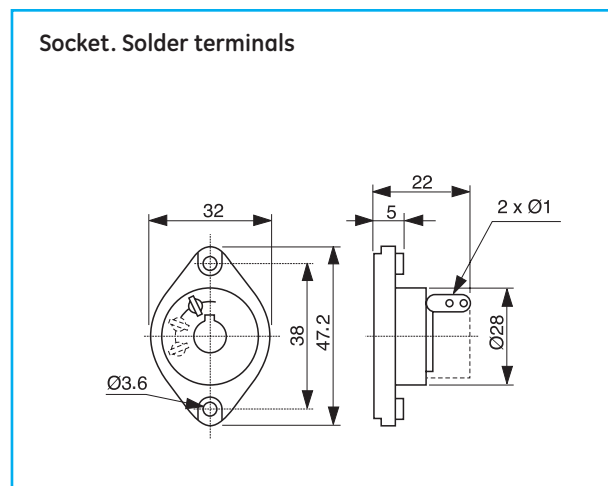
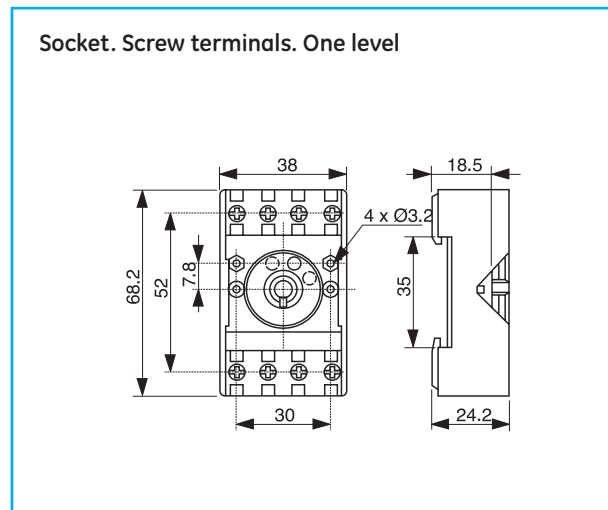
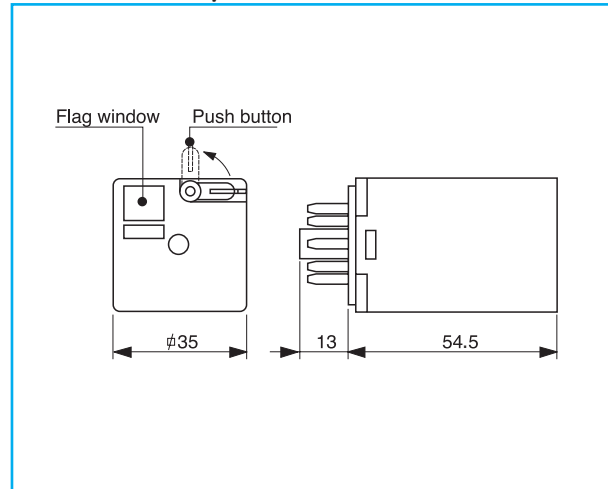

Interface relay

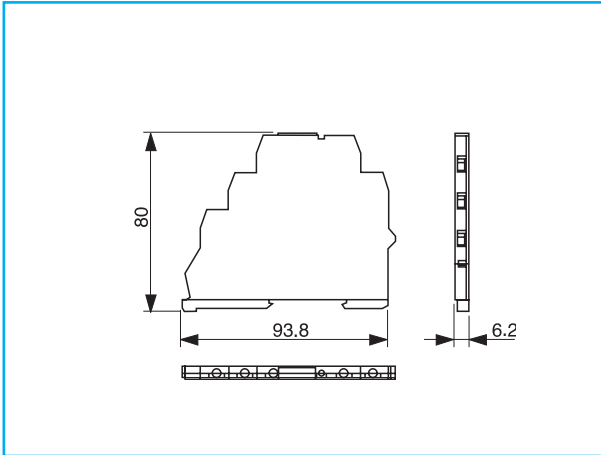

Socket for miniature P.C.B. relays

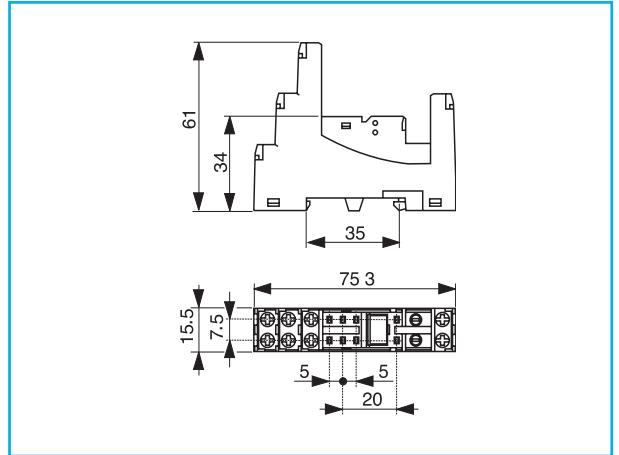

Dimensions in mm (inch = mm x 0.03937) - Weight in kg (lb = kg x 2.2046)



Technical data

General

Maximum number of contacts (MCR...)	4
Rated thermal current (I _{th}) θ ≤ 60°	16A
Rated operational voltage (U _e) acc. IEC 60947.1	690V
Insulation voltage (U _i) acc. IEC 60947.1	750V

Conformity to standards

IEC / EN 60947-5-1	IEC / EN 60947-1	BS 4794
EN 50002	EN 50005	EN 50011
NFC 63-110	NFC 63-140	CENELEC HD 420
CSA C22.2/14	VDE 0660	UL 508

Approvals

cULus	DEMKO	NEMKO
SEMKO	SETI	RINA
Lloyd's Register	Bureau Veritas	CE

Ambient conditions

Storage temperature	-55°C to +80°C	
Operation temperature	-40°C to +60°C	
Altitude	up to 3000m	Nominal values
	from 3000 to 4000m	90%le 80%Ue
	from 4000 to 5000m	80%le 75%Ue

Climatic resistance (IEC 68-2)

Continuous tests	40 / 125 / 56	
Cold (72h)	Temperature	-40°C
	Dry heat (96h)	Temperature
Humid heat (56 days)	Relative humidity	< 50%
	Temperature	+40°C
Cyclical tests (6 cycles)	Relative humidity	95%
	Humid heat	Low temperature
Relative humidity		93%
First half-cycle (12h)	Low temperature	+55°C
	Relative humidity	95%
Second half-cycle (12h)	Low temperature	+55°C
	Relative humidity	95%

Shock resistance (IEC 68-2-27)

Continuously closed (at 0.8Us)	
Admissible acceleration	25 g
Impulse duration	11ms
Continuously opened (no voltage)	
Admissible acceleration	20 g
Impulse duration	11ms

Vibration resistance (IEC 68-2-6)

Continuously closed (at 0.8Us)	
Admissible acceleration	15 g
Sweep between	10 - 200Hz
Continuously opened (no voltage)	
Admissible acceleration	5 g AC - 3.5g DC
Sweep between	10 - 200Hz

Mounting positions

With the same pick-up and drop-out voltage
With the same rated power

-7% of connection voltage
+4% of disconnection voltage
With the same rated power

-7% of connection voltage
+4% of disconnection voltage
With the same rated power

Terminal capacity

Terminal with screw M3.5 Tightening torque (with pozidrive head and safety flange)		
Solid wire	mm ²	0.75 to 2 x 2 w.
Flexible wire without terminal	mm ²	0.75 to 2.5 x 2 w.
Flexible wire with terminal with cap	mm ²	0.75 to 2.5 x 1 w.
	mm ²	0.75 to 1 x 2 w.
Ring terminal cap		0.8 Nm - 7 Lb/in

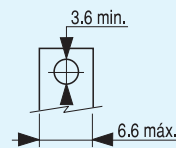

Fast-on 2.8 - 2 insulated terminals	mm ²	1 x 2 w.
Terminal for printed circuit (Ø of PCB hole)		1.8mm
Ring terminal cap		7.8mm
Fork terminal cap		6.5mm

Coil Terminal capacity and tightening torque

Tightening torque	0.8Nm - 7Lb/in	
Solid wire	(mm ²)	0.75 to 2x2
Flexible wire without terminal	(mm ²)	0.75 to 2.5x2
Flexible wire without terminal with cap	(mm ²)	0.75 to 2.5x21

Control circuit

		MCRA...	MCRC...	MCRC...	MCRI...	MCRK...
Rated insulation voltage (Ui)	(V)	750	750	750	750	750
Standard voltages (Us)						
50Hz	(V)	24..690	-	-	-	-
60Hz	(V)	6..600	-	-	-	-
DC	(V)	-	6..440	12..440	24	24
Voltage ⁽¹⁾						
Operating limits	xUs	0.8..1.1	0.8..1.1	0.7..1.3	0.8..1.25	0.7..1.25
Drop-out	xUs	0.35..0.55	0.15..0.3	0.15..0.3	0.15..0.3	0.13..0.35
Consumption						
Pick-up	(VA)	26	-	-	-	-
Seal	(VA)	4	-	-	-	-
DC	(W)	-	3	4	1.2	2
Power factor						
Pick-up	(cos φ)	0.8	-	-	-	-
Seal	(cos φ)	0.35	-	-	-	-
Power dissipation	(W)	1.4	3	4	1.2	2
Opening and closing times						
Values between ± %Us	%	+10...-20	+10...-20	+30...-30	+25...-20	+25...-20
Time at energisation NO	(ms)	6..13	22..36	17..28	30..70	20..50
Time at de-energisation NC	(ms)	8..16	9..12	9..12	9..16	9..16
Time at energisation NC	(ms)	5..11	18..27	12..25	20..45	18..35
Time at de-energisation NO	(ms)	6..13	5..7	5..7	5..9	5..9
Values at Us						
Time at energisation NO	(ms)	7..12	24..27	19..23	25..45	25..40
Time at de-energisation NC	(ms)	8..16	9..11	9..11	9..16	9..16
Time at energisation NC	(ms)	6..10	20..26	15..21	25..35	20..30
Time at de-energisation NO	(ms)	6..13	5..8	5..8	5..9	5..9
Maximum time without voltage (without effecting the closed magnetic circuit)	(ms)	3	3	3	3	3
Mechanical endurance						
Monofrequency	x10 ⁶ ops.	15	-	-	-	-
Dual-frequency	x10 ⁶ ops.	10	-	-	-	-
DC	x10 ⁶ ops.	-	10	10	10	10
Maximum rate (no load)						
Monofrequency	n° ops./h	9000	-	-	-	-
Dual-frequency	n° ops./h	3600	-	-	-	-
DC	n° ops./h	-	9000	9000	9000	9000

Contact sequence (distance in mm)

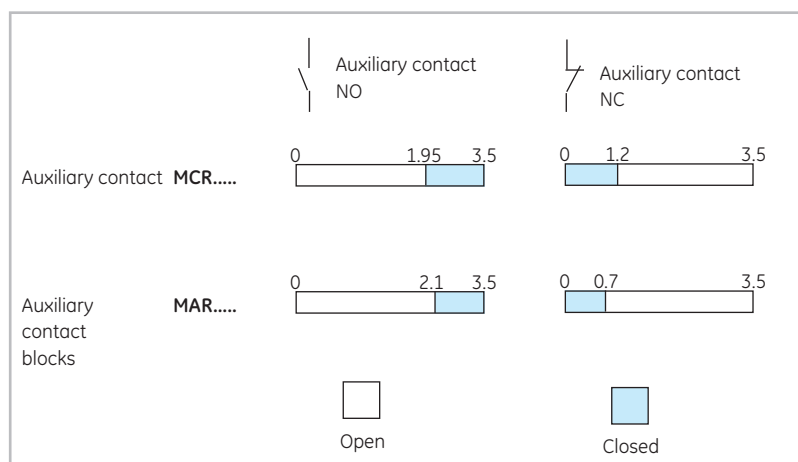

Internal auxiliary contacts

		MCR.....	
Rated insulation voltage (Ui) acc. IEC 60947-1		750V	
Rated thermal current (Ith) $\theta \leq 60^\circ\text{C}$ [1]		16A	
Making capacity (r.m.s.) acc. IEC 60947-5			
AC-15	$U_e \leq 440\text{V } 50/60\text{Hz}$	160A	
DC-13	$U_e \leq 220\text{V DC}$	3A	
Breaking capacity (r.m.s.) acc. IEC 60947-5			
AC-15	$U_e \leq 440\text{V } 50/60\text{Hz}$	106A	
DC-13 (L/R = 100 ms)	$U_e \leq 220\text{V DC}$	1.2A	
	$U_e = 110\text{V DC}$	3A	
	$U_e = 48\text{V DC}$	10A	
Rated voltage and rated current U_e - I_e			
AC-15	according to IEC 947	110/120V - 6A 220/240V - 6A 380/400V - 4A 415/440V - 4A 500V - 2.5A 660/690V - 1.5A	
	according to UL, CSA	A600	
	DC-13	according to IEC	24V - 5A 48V - 3.5 A 110V - 1.2A 220V - 0.6A 440V - 0.25A
		according to UL, CSA	P600
		Minimum operational power (operational safety)	
Short-circuit protection		10A	
(max.class gI fuse without welding)			
Insulation resistance			
	between contacts	> 10M Ω	
	between contacts and earth	> 10M Ω	
	between input and output	> 10M Ω	
Guaranteed no overlap of the contacts			
	Space	1.1mm	
	minimum time	> 2ms	
Impedance		2.3m Ω	
Terminal capacity		Same as main circuit	

Tripping characteristics (AC)

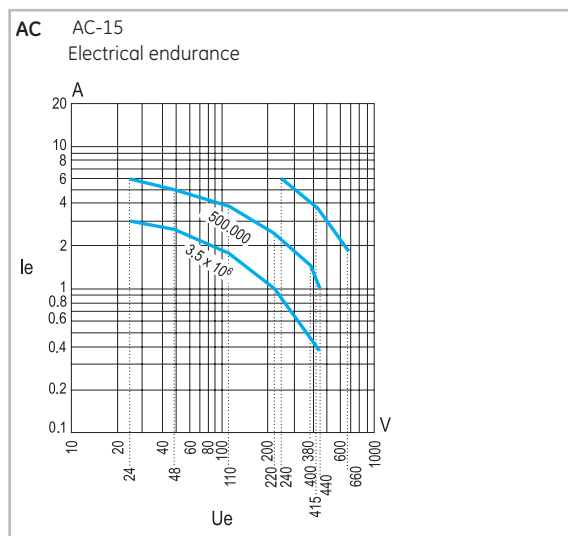

Tripping characteristics I_e/U_e

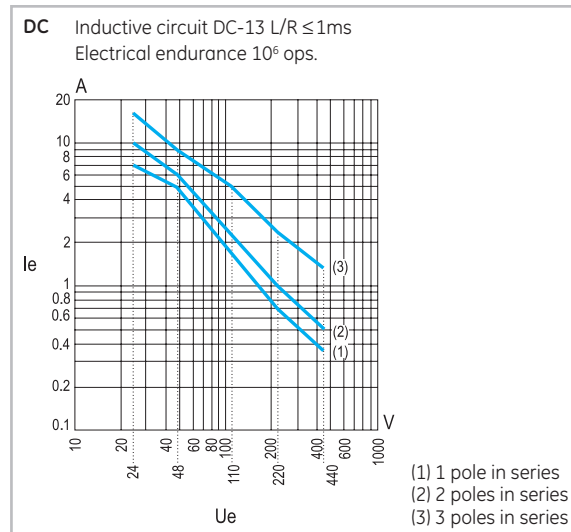
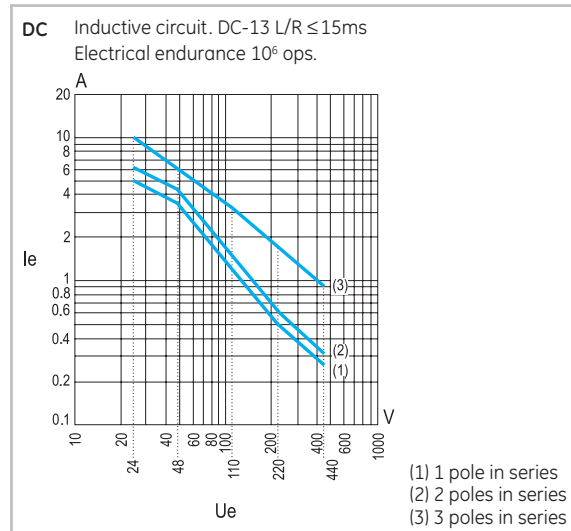
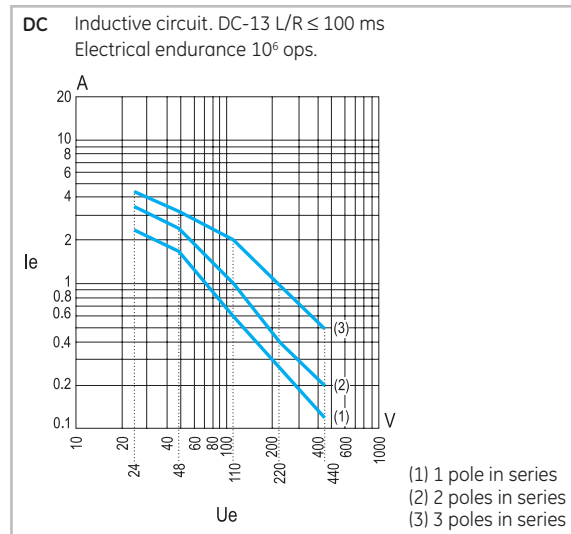

External auxiliary contact blocks

MARN..., MARL...		
Rated insulation voltage (Ui) acc. IEC 60947-1		750V
Rated thermal current (Ith) $\theta \leq 60^\circ\text{C}^{(1)}$		10A
Making capacity (r.m.s.) acc. IEC 60947-5		
AC-15	Ue \leq 220V 50/60Hz	73A
	Ue = 380V 50/60Hz	38A
	Ue = 690V 50/60Hz	22A
DC-13 L/R = 100 ms	Ue \leq 100V DC	2.6A
	Ue = 220V DC	1A
	Ue = 440V DC	0.6A
Breaking capacity (r.m.s.) acc. IEC 60947-5		
AC-15	Ue \leq 220V 50/60Hz	73A
	Ue = 380V 50/60Hz	38A
	Ue = 690V 50/60Hz	22A
DC-13 L/R = 100 ms	Ue \leq 100V DC	2A
	Ue = 220V DC	0.8A
	Ue = 440V DC	0.4A
Rated voltage and rated current Ue-Ie		
AC-15	according to IEC 60947	110/120V - 6A
		220/240V - 6A
		380/400V - 3A
		415/440V - 3A
		500V - 1A
		660/680V - 1A
	according to UL, CSA	A600
DC-13	according to IEC 60947	24V - 4A
		48V - 2A
		110V - 0.7A
		220V - 0.3A
		440V - 0.1A
	according to UL, CSA	Q600
Minimum operational power (operational safety)		
		5mA, 17V
Short-circuit protection		
	(max.class g) fuse without welding	10A
Insulation resistance		
	between contacts	> 10M Ω
	between contacts and earth	> 10M Ω
	between input and output	> 10M Ω
Guaranteed no overlap of the contacts		
	Space	0.5mm
	minimum time	> 2ms
Impedance		
		2.4m Ω
Terminal capacity		
		Same as main circuit

Tripping characteristics (AC)

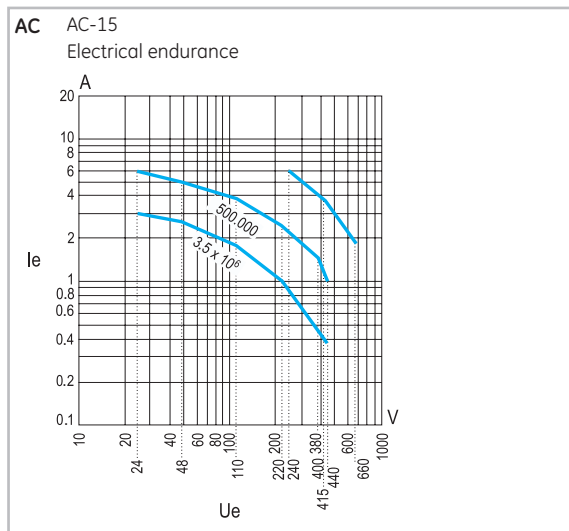

Tripping characteristics Ie/ue

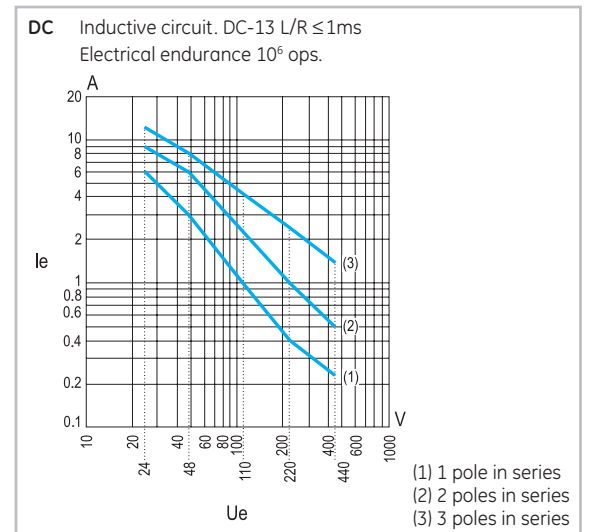
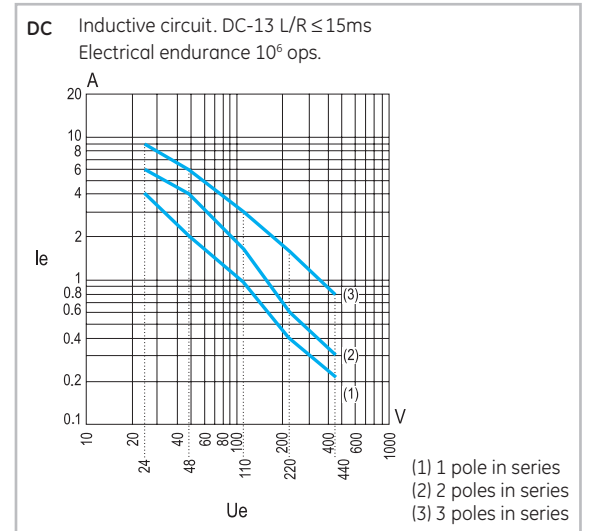
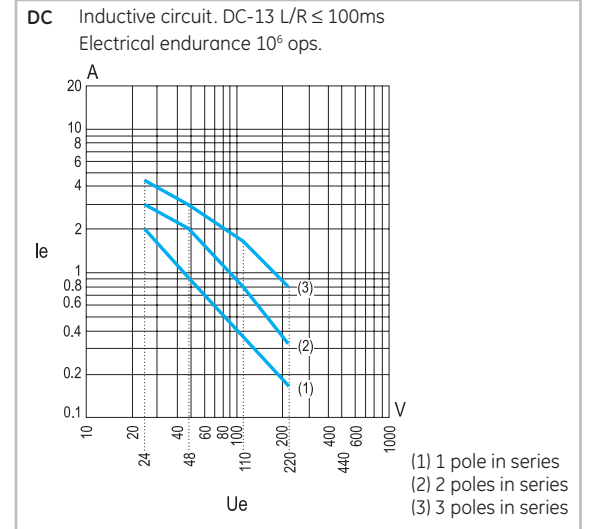

Electronic timer block

		MREBC...
Rated insulation voltage (Ui)		750V
Rated thermal current (Ith) $\theta \leq 60^{\circ}\text{C}$ ⁽¹⁾		0.55V
Standard voltages (AC y DC)		24 to 250V
Operation limits		0.80 to 1.1 Us (0.85 to 1.1 Us at 12V)
Voltage drop		< 3V
Maximum load current at		
	20°C	0.9A
	40°C	0.72A
	60°C	0.55A
Minimum load for safe operation		> 10mA
Maximum current (peak)		10A for 40ms
Leakage current at 220V		< 5mA
Operational current		
	AC-15	0.7A
	DC-13	0.9A
Timing range (delay ON)		0.5 to 60s (\pm 6s)
Rearrangement time		< 100ms
Repeatability (accuracy)		\pm 1%
Ambient temperature		
	Storage	from -55 up to + 80°C
	Operation	from -5 up to + 60°C
Degree of protection		IP20
Mounting position		any
Terminals : 2 free cables		1mm ² (AWG 17) 250mm

MREBC_0AC2

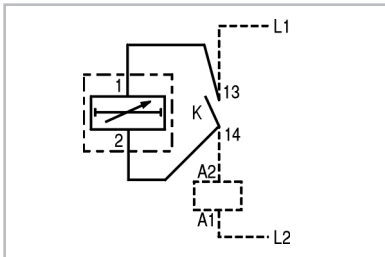

Terminal numbering

Auxiliary contactors. According to EN 50011

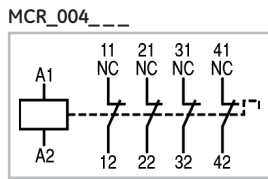
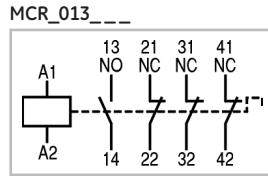
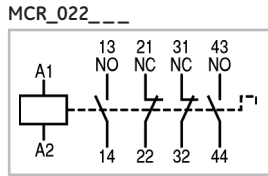
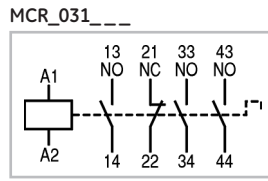
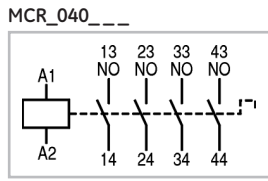

Auxiliary contact blocks

According to EN 50005 & EN 50011

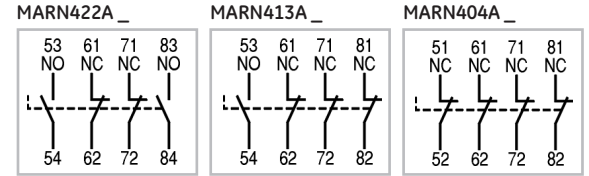
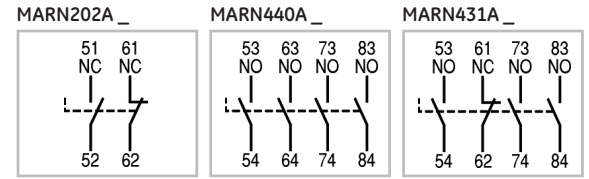
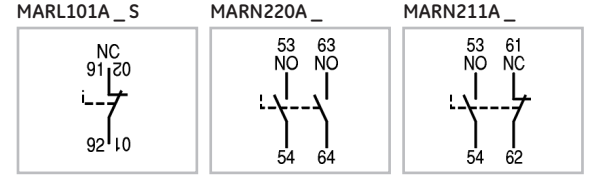
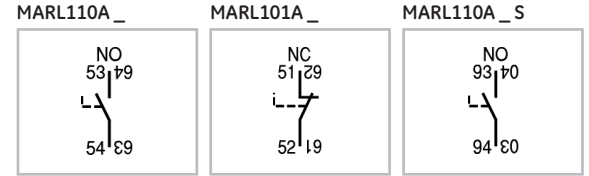

Transient voltage suppressor block

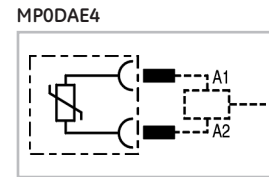
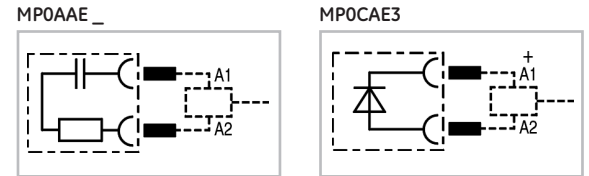







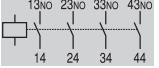
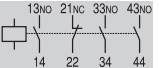
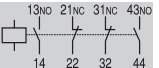
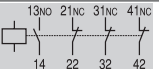
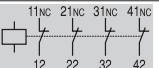

Terminal numbering in accordance with EN 50011

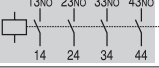
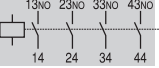
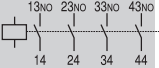
By combining other basic auxiliary contactors with auxiliary contact blocks MAR..., it is possible to obtain other combinations, and positions of contacts which are not covered by the table. But in all cases the maximum number of auxiliary contacts should be ten.

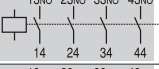
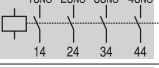
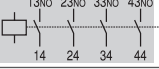
Type E

Standard contact combination in which the interchangeability of the devices does not affect the cabling or the diagram. Specifies a particular contact numbering and positioning.

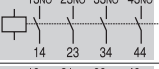
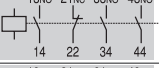
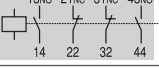
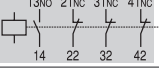
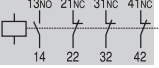
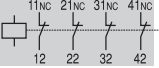
	Final structure of the combination	Auxiliary contacts		Auxiliary contactor + Auxiliary contact blocks to be added	
		Combination	NO NC		
Type E		Description			
		40E	4 0	MCRA040A..	
		31E	3 1	MCRA031A..	
		22E	2 2	MCRA022A..	
		13E	1 3	MCRA013A..	
		04E	0 4	MCRA004A..	
			60E	6 0	MCRA040A.. + MARN220A..
			51E	5 1	MCRA040A.. + MARN211A..
			42E	4 2	MCRA040A.. + MARN202A..
			80E	8 0	MCRA040A.. + MARN440A..
			71E	7 1	MCRA040A.. + MARN431A..
			62E	6 2	MCRA040A.. + MARN422A..
			53E	5 3	MCRA040A.. + MARN413A..
			44E	4 4	MCRA040A.. + MARN404A..
				50E	5 0
			41E	4 1	MCRA031A.. + MARL110A..
			32E	3 2	MCRA022A.. + MARL110A..
			23E	2 3	MCRA013A.. + MARL110A..
			14E	1 4	MCRA013A.. + MARL101A..
	05E		0 5	MCRA004A.. + MARL101A..	



Terminal numbering in accordance with EN 50011 (continued)

By combining other basic auxiliary contactors with auxiliary contact blocks MAR..., it is possible to obtain other combinations, and positions of contacts which are not covered by the table. But in all cases the maximum number of auxiliary contacts should be ten.

Type Z

Contact combination the same as Type E. Interchangeability of the devices may affect the cabling and the diagram. Neither contact numbering nor positioning are retained.

Type X

Contact combination the same as Type E. Interchangeability of the devices may affect the cabling but not the diagram. The contact numbering is maintained but not their position.

Type Y

Contact combination which differs from Type E, although it is obtained by a combination of devices provided for this Type E.

	Final structure of the combination	Auxiliary contacts		Auxiliary contactor + Auxiliary contact blocks to be added	
		Combination Description	NO NC		
Type Z			6 0	MCRA040A.. + MARL110A.. + MARL110A..	
			5 1	MCRA040A.. + MARL110A.. + MARL101A..	
			4 2	MCRA040A.. + MARL101A.. + MARL101A..	
			10 0	MCRA040A.. + MARN440A.. + MARL110A..S + MARL110A..S	
			5 5	MCRA040A.. + MARN413A.. + MARL101A..S + MARL101A..S	
	Type X			8 0	MCRA040A.. + MARL110A.. + MARL110A.. + MARL110A..S + MARL110A..S
			7 1	MCRA040A.. + MARL110A.. + MARL101A.. + MARL110A..S + MARL110A..S	
			6 2	MCRA040A.. + MARL110A.. + MARL101A.. + MARL101A..S + MARL110A..S	
			5 3	MCRA040A.. + MARL110A.. + MARL101A.. + MARL101A..S + MARL101A..S	
			4 4	MCRA040A.. + MARL101A.. + MARL101A.. + MARL101A..S + MARL101A..S	
			9 1	MCRA040A.. + MARN431A.. + MARL110A..S + MARL110A..S	
			8 2	MCRA040A.. + MARN431A.. + MARL101A..S + MARL110A..S	
			7 3	MCRA040A.. + MARN422A.. + MARL101A..S + MARL110A..S	
			6 4	MCRA040A.. + MARN422A.. + MARL101A..S + MARL101A..S	
Type Y				4 2	MCRA031A.. + MARL110A.. + MARL101A..
				3 3	MCRA022A.. + MARL110A.. + MARL101A..
				4 2	MCRA031A.. + MARN211A..
			3 3	MCRA022A.. + MARN211A..	
			5 3	MCRA031A.. + MARN422A..	
			4 4	MCRA022A.. + MARN422A..	

Dimensional drawings

Auxiliary minicontactors

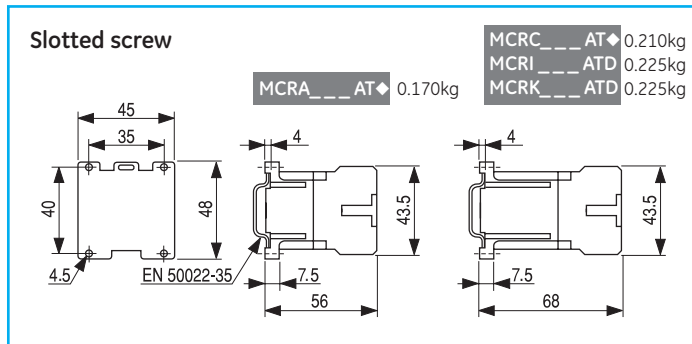

Auxiliary contact blocks. Front mounting

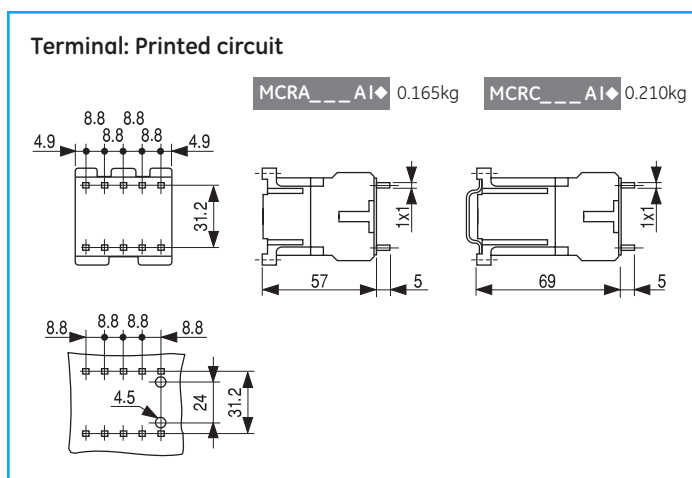
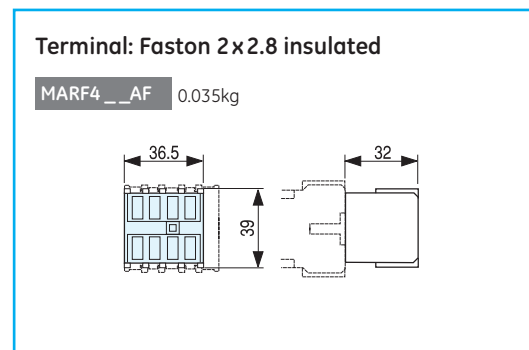
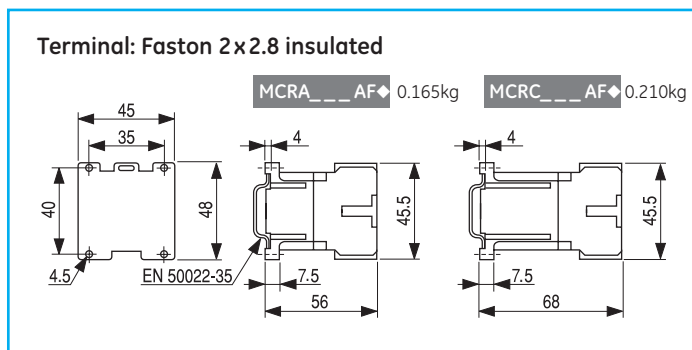
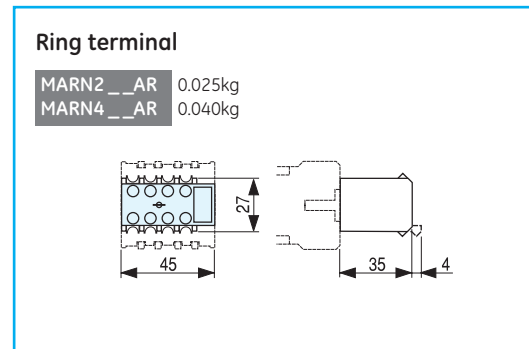
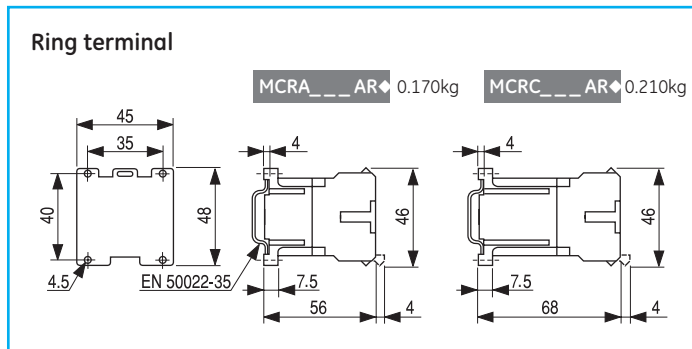
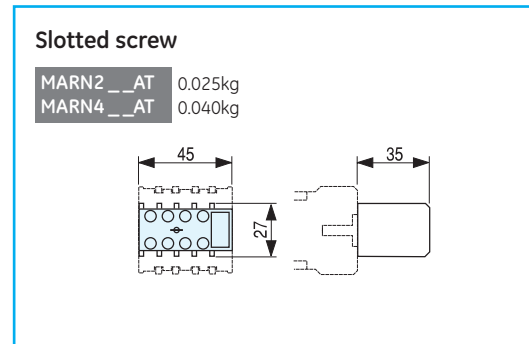

Dimensions in mm (inch = mm x 0.03937) - Weight in kg (lb = kg x 2.2046)



Auxiliary contact blocks. Lateral mounting

Slotted screw

MARL__AT, ATS 0.013kg

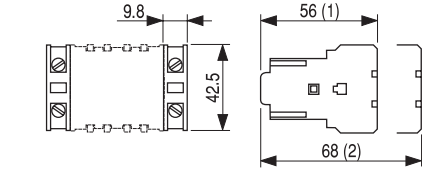

- (1) AC-control.
- (2) DC-control

Electronic timer block

MREBC_0AC2 0.040kg

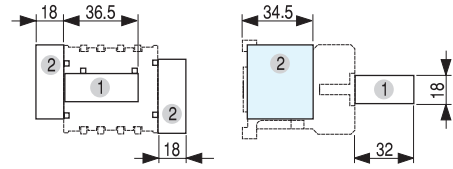

- (1) Frontal mounting
- (2) Lateral mounting

Ring terminal

MARL__AR, ARS 0.013kg

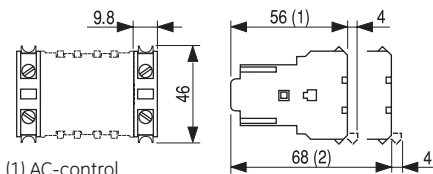

- (1) AC-control.
- (2) DC-control

Voltage suppressor block

MPOA_AE_ 0.010kg
MPOC_AE3 0.010kg

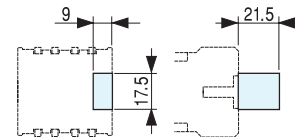

Terminal: Faston 2x2.8 insulated

MARL__AF, AFS 0.009kg

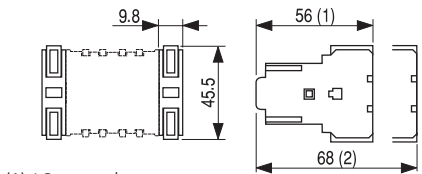

- (1) AC-control.
- (2) DC-control

Terminal: Printed circuit

MARL__AI, AIS 0.009kg

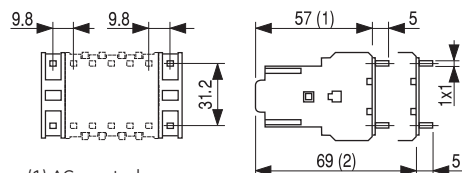

- (1) AC-control
- (2) DC-control

Dimensions in mm (inch = mm x 0.03937) - Weight in kg (lb = kg x 2.2046)

General

Maximum number of contacts	4
Rated thermal current (I _{th}) θ < 55°C	20A
Rated operational voltage (U _e)	690V
Insulation voltage (U _i)	1000V

Conformity to standards

IEC / EN 60947-1	IEC / EN 60947-5-1	ASE 1025
EN 50005	EN 50011	VDE 0660 / 102
NFC 63-110	NFC 63-140	
CENELEC HD 410	CENELEC HD 420	
NEMA ICS 1	CSA C22.2/14	
UL 508	BS 4794	

Approvals/Marking

cULus	DEMKO	NEMKO
SEMKO	FI	CE
Lloyd's Register	Bureau Veritas	

Ambient conditions

Storage temperature	-55°C to +80°C	
Operation temperature	-40°C to +60°C	
Altitude	up to 3000m	Nominal values
	from 3000 to 4000m	90%le 80%Ue
	from 4000 to 5000m	80%le 75%Ue

Climatic resistance (IEC 68-2)

Continuous tests	40 / 125 / 56	
Cold (72h)	Temperature	-40°C
	Relative humidity	< 50%
	Humid heat (56 days)	
Dry heat (96h)	Temperature	+125°C
	Relative humidity	95%
	Humid heat (56 days)	
Humid heat (56 days)	Temperature	+40°C
	Relative humidity	95%
	Cyclical tests (6 cycles)	
Humid heat	First half-cycle (12h)	
	Low temperature	+25°C
	Relative humidity	93%
Second half-cycle (12h)	Low temperature	+55°C
	Relative humidity	95%

Mounting positions

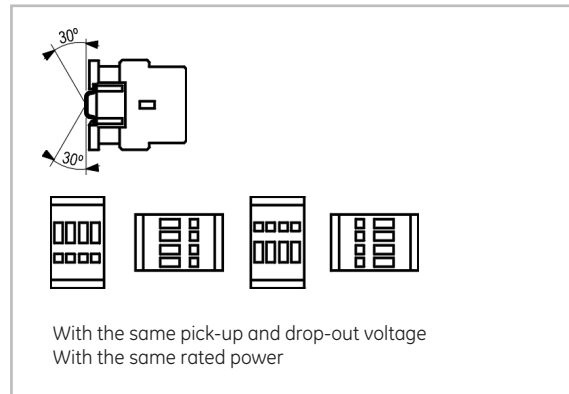

Control circuit

	RL4RA...	RL4RD...	RL4RD...W
Rated insulation voltage U _i (V)	1000	1000	1000
Standard voltages U _s			
50Hz (V)	24 ... 690	-	-
60Hz (V)	24 ... 600	-	-
DC (V)	-	12 ... 440	12 ... 440
Voltage ¹⁾			
Operating limits	xUs 0.8 ... 1.1	0.8 ... 1.1	0.7 ... 1.3
Pick-up	xUs 0.65 ... 0.75	0.45 ... 0.65	0.45 ... 0.55
Seal	xUs 0.4 ... 0.55	0.15 ... 0.3	0.15 ... 0.3
Consumption			
AC Magnetic circuit closed (VA)	6	-	-
AC Magnetic circuit open (VA)	45	-	-
DC Magnetic circuit closed (W)	-	5.5	6.5
DC Magnetic circuit open (W)	-	5.5	6.5
Power dissipation (W)	2.4	5.5	6.5
Power factor			
Magnetic circuit closed	cos φ 0.34	-	-
Magnetic circuit open	cos φ 0.82	-	-
Opening and closing times			
at 0.8 to 1.1 U _s			
Closing time NO (ms)	6 ... 25	35 ... 65	25 ... 65
Opening time NO (ms)	6 ... 13	6 ... 13	6 ... 13
at U _s			
Closing time NO (ms)	8 ... 20	35 ... 45	25 ... 55
Opening time NO (ms)	6 ... 13	7 ... 12	6 ... 13
Mechanical endurance	10 ⁶ ops	15	15
Maximum rate no load (ops/h)	9000	3600	3600

Contact sequence (distance in mm)

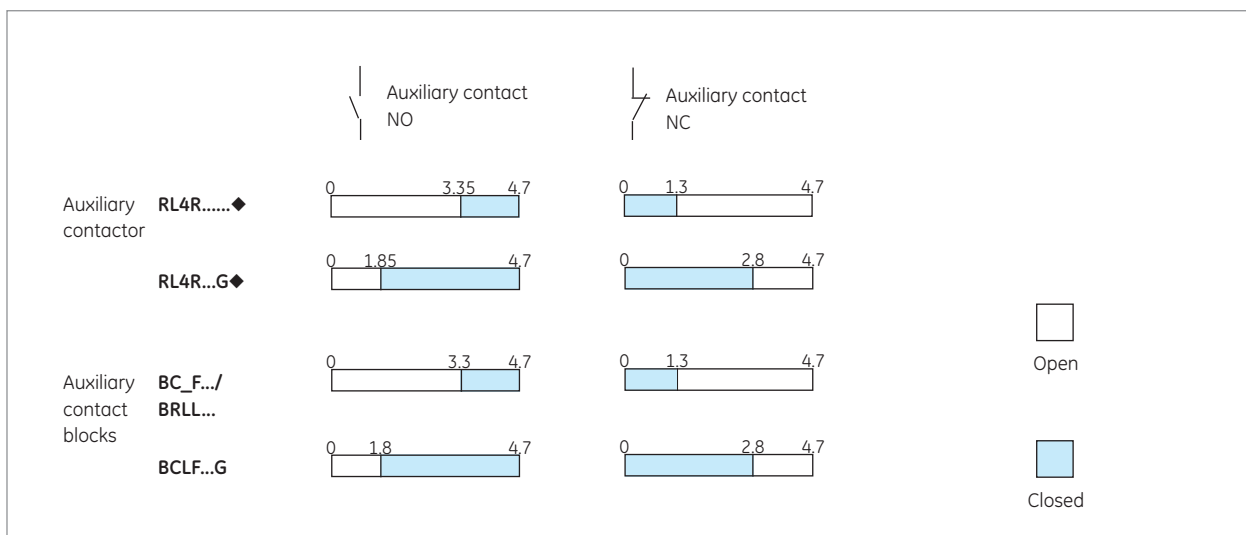

Internal auxiliary contacts

		RL4.....
Rated insulation voltage (Ui) acc. IEC 60947-5		1000V
Rated thermal current (Ith) $\theta < 55^{\circ}\text{C}$		20A
Making capacity (r.m.s.) acc. IEC 60947-5		
AC-15	$U_e \leq 400\text{V}, 50/60\text{Hz}$	250A
DC-13	$U_e \leq 220\text{V DC}$	250A
Breaking capacity (r.m.s.) acc. IEC 60947-5		
AC-15	$U_e \leq 400\text{V}, 50/60\text{Hz}$	250A
DC-13	$U_e \leq 220\text{V DC}$	2A (4A with 2 contacts in series)
	$U_e \leq 110\text{V DC}$	7A (12A with 2 contacts in series)
	$U_e \leq 48\text{V DC}$	10A (18A with 2 contacts in series)
Rated voltage and rated current $U_e\text{-}I_e$		
AC-15	according to IEC	110/120V - 10A 220/240V - 10A 380/400V - 6A 415/440V - 5A 500V - 4A 660/690V - 2A
	according to UL, CSA	A600
DC-13	according to IEC	24V - 6A 48V - 4A 110V - 2A 220V - 0.7A 440V - 0.35A
	according to UL, CSA	P600
Electrical endurance		1×10^6 ops.
Minimum operational voltage (operational safety)		17V
Minimum operational current		5mA
Short-circuit protection		
	max. fus. class gL fuse without welding	20A 10A
Insulation resistance		
	between contacts	$> 10\text{m}\Omega$
	between contacts and earth	$> 10\text{m}\Omega$
	between input and output	$> 10\text{m}\Omega$
Guaranteed no overlap between NO and NC contacts		
	space	1.3mm
	minimum time	1.5ms
Impedance		1.28m Ω

Terminal capacity

Solid, stranded and finely stranded without end sleeve	mm ²	2x0.5 to 6
Finely stranded with end sleeve	mm ²	2x1 to 6
AWG wires, solid and stranded	mm ²	2x20 to 12
Tightening torque		1.1 Nm / 10 Lb.in
Ring terminals		1.6 Nm / 15 Lb.in

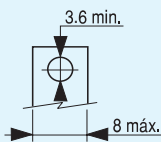

Coil Terminal capacity and tightening torque

Tightening torque		0.8Nm - 7Lb/in
Solid wire	(mm ²)	0.75 to 2x2
Flexible wire without terminal	(mm ²)	0.75 to 2.5x2
Flexible wire without terminal with cap	(mm ²)	0.75 to 2.5x21

Instantaneous auxiliary contact blocks

		BCLF../BCRF../BRLL..
Rated insulation voltage (Ui) acc. IEC 60947-5		1000V
Rated thermal current (Ith) $\theta < 55^{\circ}\text{C}$		10A
Making capacity (r.m.s.) acc. IEC 60947-5		
AC-15	$U_e \leq 440\text{V}, 50/60\text{Hz}$	90A
DC-13	$U_e \leq 220\text{V DC}$	90A
Breaking capacity (r.m.s.) acc. IEC 60947-5		
AC-15	$U_e \leq 400\text{V}, 50/60\text{Hz}$	60A
DC-13	$U_e \leq 220\text{V DC}$	0.95A
Rated voltage and rated current $U_e\text{-}I_e$		
AC-15	according to IEC	110/120V - 6A 220/240V - 6A 380/400V - 4A 415/440V - 3.5A 500V - 2.5A 660/690V - 1.5A
	according to UL, CSA	A600
DC-13		24V - 4A 48V - 2A 110V - 0.7A 220V - 0.3A 415/440V - 0.15A
	according to UL, CSA	Q600
Electrical endurance		1×10^6 ops.
Minimum operational voltage (operational safety)		17V
Minimum operational current		5mA
Short-circuit protection (without welding) gL		10A
Insulation resistance		
	between contacts	$> 10\text{m}\Omega$
	between contacts and earth	$> 10\text{m}\Omega$
	between input and output	$> 10\text{m}\Omega$
Guaranteed no overlap between NO and NC contacts		
	Space	1.3mm
	minimum time	1.5ms
Impedance of the contacts		1.28m Ω

Terminal capacity

Solid, stranded and finely stranded without end sleeve	mm ²	2x0.5 to 2.5 2x2.5 to 4
Finely stranded with end sleeve	mm ²	2x0.5 to 2.5 2x2.5 to 4
AWG wires, solid and stranded	mm ²	2x20 to 10
Tightening torque		0.8 Nm / 7 Lb.in
Ring terminals		0.8 Nm / 7 Lb.in

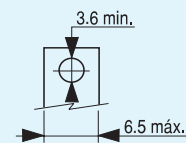

Timed auxiliary contact blocks

	BTLF... / BTRF...
Rated insulation voltage (Ui) acc. IEC 60947-5	1000V
Rated thermal current (Ith) $\theta < 55^{\circ}\text{C}$	10A
Making capacity (r.m.s.) acc. IEC 60947-5	
AC-15 $U_e \leq 440\text{V}, 50/60\text{Hz}$	90A
DC-13 $U_e \leq 220\text{V DC}$	90A
Breaking capacity (r.m.s.) acc. IEC 60947-5	
AC-15 $U_e \leq 400\text{V}, 50/60\text{Hz}$	60A
DC-13 $U_e \leq 220\text{V DC}$	0.95A
Rated voltage and rated current U_e - I_e	
AC-15 according to IEC	110/120V - 6A 220/240V - 6A 380/400V - 4A 415/440V - 3.5A 500V - 2.5A 660/690V - 1.5A
	according to UL, CSA A600
DC-13 according to IEC	24V - 4A 48V - 2A 110V - 0.7A 220V - 0.3A 415/440V - 0.15A
	according to UL, CSA Q600
Electrical endurance	1×10^6 ops.
Minimum operational voltage (operational safety)	17V
Minimum operational current	5mA
Short-circuit protection (without welding) gL	10A
Insulation resistance	
between contacts	$> 10\text{M}\Omega$
between contacts and earth	$> 10\text{M}\Omega$
between input and output	$> 10\text{M}\Omega$
Guaranteed no overlap between NO and NC contacts	
space	1.3mm
minimum time	1.5ms
Timing	
(Ambient temperature between $- 25$ and $+ 55^{\circ}\text{C}$)	
Accuracy	$\pm 5\%$
Loss of accuracy after 0.5×10^6 ops.	+ 20%
Loss of accuracy per rise $^{\circ}\text{C}$ (0 - 55°C)	+ 0.75 % per $^{\circ}\text{C}$
Impedance of the contacts	1.28m Ω
Mechanical endurance	5×10^6 ops.
Peak current	
during 1 s.	50A
during 0.1 s.	100A

Terminal capacity

Solid, stranded and finely stranded without end sleeve	(mm ²)	2 x 0.5 to 2.5 2 x 2.5 to 4
Finely stranded with end sleeve	(mm ²)	2 x 0.5 to 2.5 2 x 2.5 to 4
AWG wires, solid and stranded	(mm ²)	2 x 20 to 10
Tightening torque		0.8 Nm / 7 Lb.in
Ring terminals		0.8 Nm / 7 Lb.in

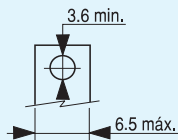

Mechanical latch blocks

	RMLF.....
Rated insulation voltage (Ui)	1000V
Standard voltages (Us): 50-60Hz and direct current	24 ... 690V
Operating limits	0.75 to 1.1 x Us
Consumption for unlatching (auto cut-out)	210W /VA (24-72V) 130W /VA (110-440V)
Unlatching control ⁽¹⁾	
Electrical Min.impuls	10 ms Maintained auto cut-out by integral contact 55-56 (only AC slots)
Manual	By local (0) push-button
Contactor control	
Electrical Min.impuls	40 ms
Manual	By local (I) push-button
Mechanical endurance RL4	3×10^6 (1200ops./h)

Terminal capacity

Solid, stranded and finely stranded without end sleeve	mm ²	2 x 0.5 to 2.5 2 x 2.5 to 4
Finely stranded with end sleeve	mm ²	2 x 0.5 to 2.5 2 x 2.5 to 4
AWG wires, solid and stranded	mm ²	2 x 20 to 10
Tightening torque		0.8 Nm / 7 Lb.in

Terminal numbering

Auxiliary contactors

RL4R_040__

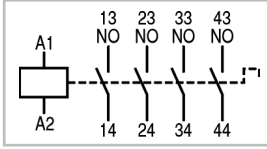

RL4R_031__

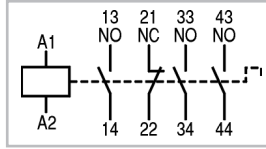

RL4R_022__

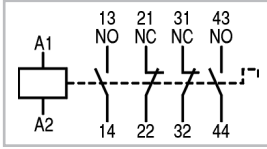

RL4R_004__

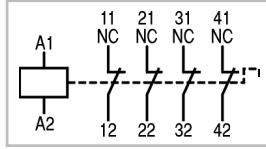

RL4R_022G_

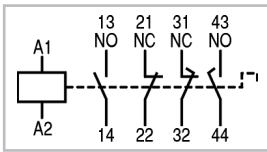

Mechanical (-/electrical) interlock

BELA, BEL



BELA02, BELO2

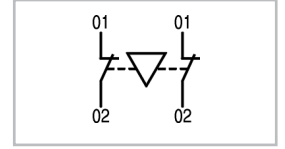

Mechanical latch block

RMLF

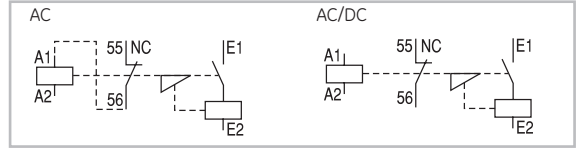

Voltage suppressor blocks

BSLR2

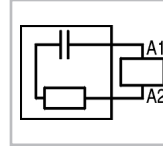

BSLDZ

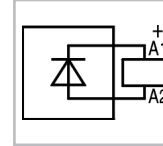

BSLV3

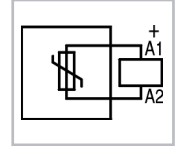

Auxiliary contact blocks. Front mounting

BC_F10



BC_F01

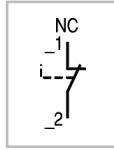

BCLF10G

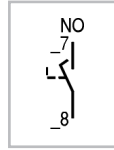

BCLF01G

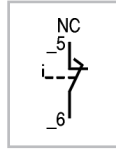

Auxiliary contact blocks. Lateral mounting

BRLL20

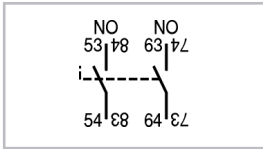

BRLL11

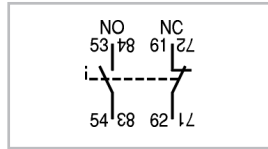

Pneumatic timer blocks

BT_F_C

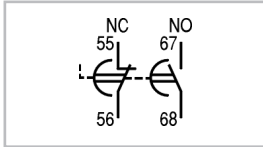

BT_F_D

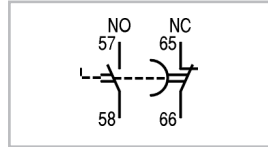

Electronic timer blocks

BETL_C

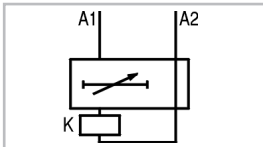

BETL_D

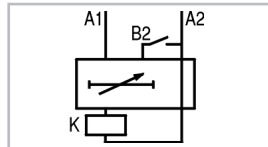

Terminal numbering in accordance with EN 50011

By combining other basic auxiliary contactors with auxiliary contact blocks BLC..., it is possible to obtain other combinations, and positions of contacts which are not covered by the table. But in all cases the maximum number of additional auxiliary contacts should be four.

Type E

Standard contact combination in which the interchangeability of the devices does not affect the cabling or the diagram. Specifies a particular contact numbering and positioning.

	Final structure of the combination	Auxiliary contacts		Auxiliary contactor +Auxiliary contact blocks to be added	
		Combination	NO NC		
Type E		Description			
		40E	4 0	RL4RA040...	
		31E	3 1	RL4RA031...	
		22E	2 2	RL4RA022...	
		04E	0 4	RL4RA004...	
			50E	5 0	RL4RA040... + BC_F10
			41E	4 1	RL4RA031... + BC_F10
			32E	3 2	RL4RA022... + BC_F10
			23E	2 3	RL4RA022... + BC_F01
			14E	1 4	RL4RA004... + BC_F10
			05E	0 5	RL4RA004... + BC_F01
			60E	6 0	RL4RA040... + BC_F10 + BC_F10
			51E	5 1	RL4RA040... + BC_F10 + BC_F01
		42E	4 2	RL4RA040... + BC_F01 + BC_F01	
		80E	8 0	RL4RA040... + BC_F10 + BC_F10 + BC_F10 + BC_F10	
		71E	7 1	RL4RA040... + BC_F10 + BC_F01 + BC_F10 + BC_F10	
		62E	6 2	RL4RA040... + BC_F10 + BC_F01 + BC_F01 + BC_F10	
		53E	5 3	RL4RA040... + BC_F10 + BC_F01 + BC_F01 + BC_F01	
		44E	4 4	RL4RA040... + BC_F01 + BC_F01 + BC_F01 + BC_F01	



Terminal numbering in accordance with EN 50011 (continued)













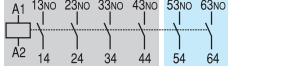

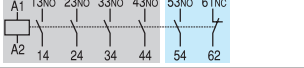

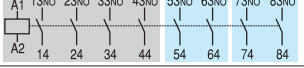

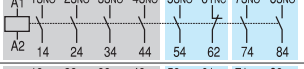

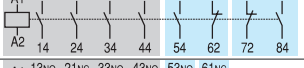

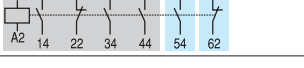

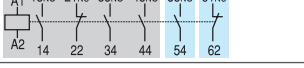

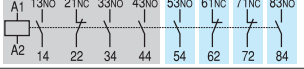

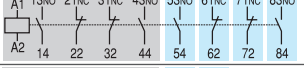

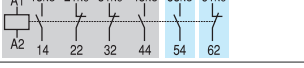
By combining other basic auxiliary contactors with auxiliary contact blocks BLC..., it is possible to obtain other combinations, and positions of contacts which are not covered by the table. But in all cases the maximum number of additional auxiliary contacts should be four.

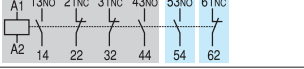
Type Z

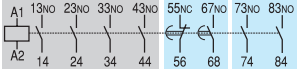
Contact combination the same as Type E.
Interchangeability of the devices may affect the cabling and the diagram. Neither contact numbering nor positioning are retained.

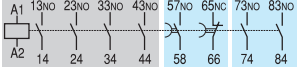
Type Y

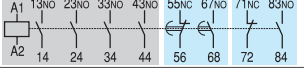
Contact combination which differs from Type E, although it is obtained by a combination of devices provided for this Type E.

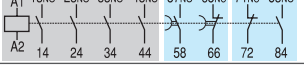
	Final structure of the combination	Auxiliary contacts		Auxiliary contactor +Auxiliary contact blocks to be added
		Combination Description	 NO  NC	
Type Z	 	60Z	6 0	RL4RA040... + BRL20
	 	51Z	5 1	RL4RA040... + BRL11
	 	80Z	8 0	RL4RA040... + BRL20 + BRL20
	 	71Z	7 1	RL4RA040... + BRL11 + BRL20
	 	62Z	6 2	RL4RA040... + BRL11 + BRL11
Type Y	 	42Y	4 2	RL4RA031... + BC_F10 + BC_F01
	 	42Y	4 2	RL4RA031... + BRL11
	 	53Y	5 3	RL4RA031... + BC_F10 + BC_F01 + BC_F01 + BC_F10
	 	44Y	4 4	RL4RA022... + BC_F10 + BC_F01 + BC_F01 + BC_F10
	 	33Y	3 3	RL4RA022... + BC_F10 + BC_F01
	 	33Y	3 3	RL4RA022... + BRL11
	 			RL4RA040... + BTLF...C + BRL20
	 			RL4RA040... + BTLF...D + BRL20
	 			RL4RA040... + BTLF...C + BRL11
	 			RL4RA040... + BTLF...D + BRL11

Dimensional drawings

Auxiliary contactors

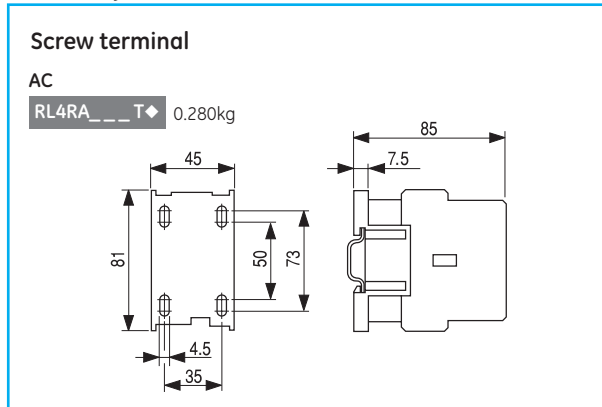

Instantaneous auxiliary contact blocks

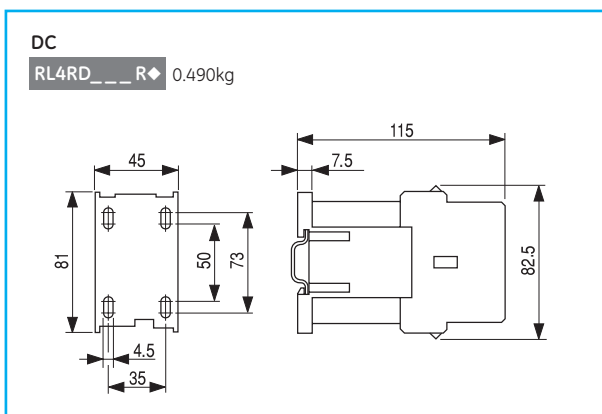
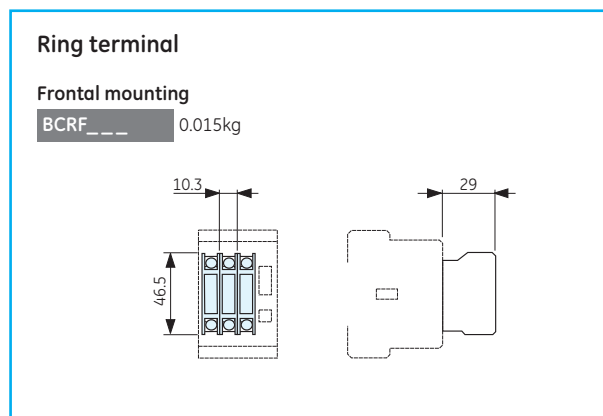
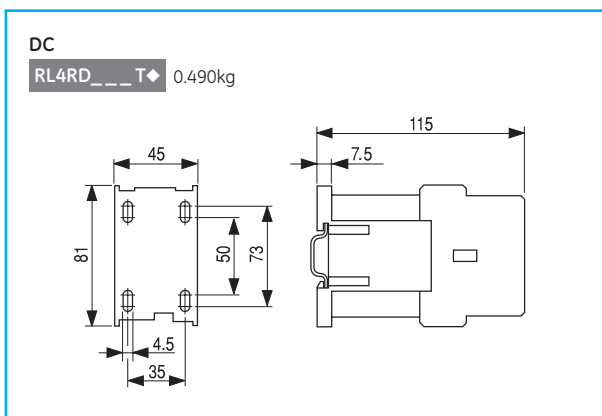
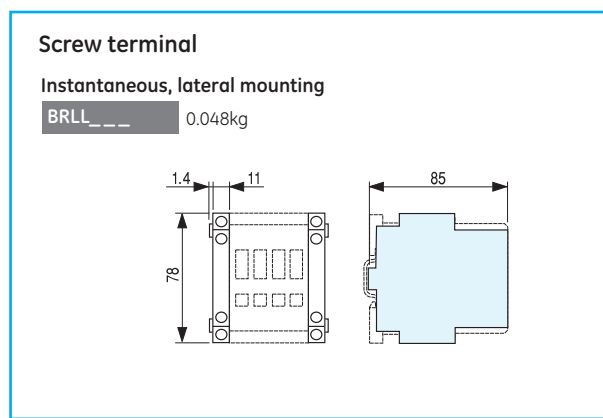
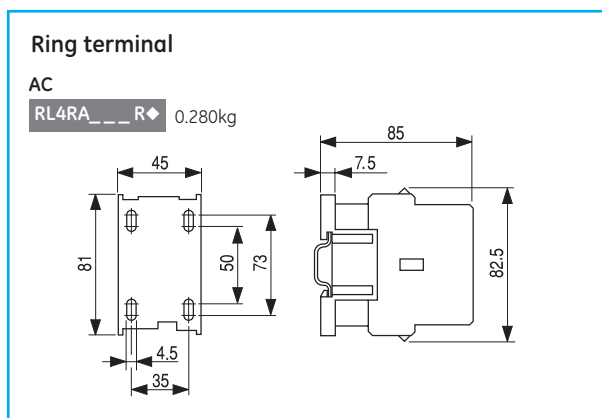
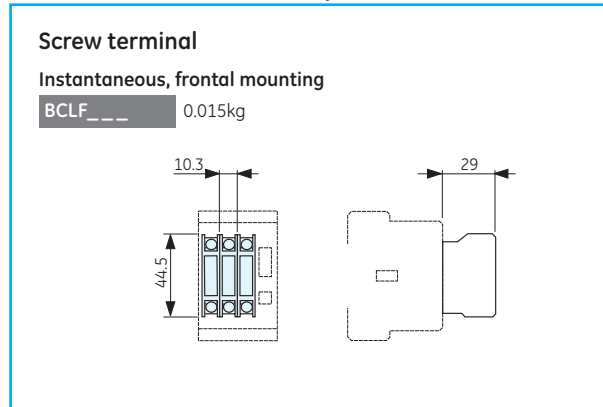

Dimensions in mm (inch = mm x 0.03937) - Weight in kg (lb = kg x 2.2046)



Timed auxiliary contact blocks

Screw terminal
Front mounting
BTLF____ 0.085kg

Ring terminal
Front mounting
BTRF____ 0.085kg

Mechanical (-/electrical) interlock

BELA 0.025kg
BELA02 0.025kg

Mechanical latch block

RMLF___ 0.082kg

Voltage suppressor blocks

BSLR2_ 0.020kg
BSLDZ_ 0.020kg
BSLV3_ 0.020kg

Electronic timer block

BETL__C 0.040kg
BETL__D 0.040kg

Interface

IMR_ 0.060kg
IMRF_ 0.050kg
IMSSD 0.045kg
IMAMS 0.045kg

Dimensions in mm (inch = mm x 0.03937) - Weight in kg (lb = kg x 2.2046)



Conformity to standards

IEC/EN 60947-1	GB14048.4
IEC/EN 60947-5-1	UL508
EN50011	UL486E
EN50012	CSA2.22-14
EN50005	NF F16 101/102

Ambient conditions

Storage temperature	-55°C to +80°C
Operation temperature	-40°C to +55°C
Without TOR	-40°C to +60°C
	-40°C to +70°C ^[1]
Altitude	<2000m

(1) From 100% to 110% of rated control voltage, no auxiliary blocks

Approvals/Marking



Climatic resistance (IEC 68-2)

Continuous tests 40 / 125 / 56	
Cold (72h)	Temperature -40°C
Dry heat (96h)	Temperature +125°C Relative humidity < 50%
Humid heat (56h)	Temperature +40°C Relative humidity 95%
Cyclic test (6 cycles)	
First half-cycle	Low temperature +25°C Relative humidity 93%
Second half-cycle	Low temperature +55°C Relative humidity 95%

Mounting positions

Installation capabilities

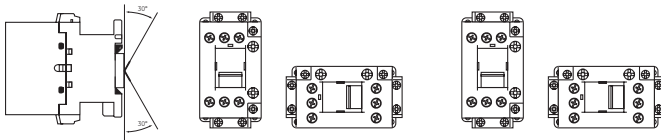

With derating values



-10% connection voltage
+10% disconnection voltage with same rated power, data compared to vertical mounting

Terminal capacity and tightening torque

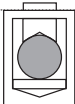
	Conventional thermal current (Ith)	
	Head type	ECAC
	Box terminals	
	Solid, stranded and finely stranded without ferrule (mm ²)	Slot & PZ2 0.75
	Finely stranded with ferrule (mm ²)	Slot & PZ2 0.75
	Finely stranded without ferrule (mm ²)	Slot & PZ2 0.75
	AWG	18 ... 10
Tightening torque	(Nm)	2.2
	(Lb x in.)	20

Coil Terminal capacity and tightening torque

Tightening torque		0.8Nm - 7Lb/in
Solid wire (mm ²)		0.75 to 2x2
Flexible wire without terminal (mm ²)		0.75 to 2.5x2
Flexible wire without terminal with cap (mm ²)		0.75 to 2.5x21

Control circuit

		ECACA	ECACD	ECACE
Rated insulation voltage Ui	(V)	1000	1000	1000
Standard voltages Us				
50Hz (V)		24 ... 690	-	24-250
60Hz (V)		24 ... 600	-	24-250
DC	(V)	-	12 ... 440	24-250
Voltage ^[1]				
Operating limits	xUs	0.8 ... 1.1	0.7 ^[1] ... 1.25 ^[1]	0.8 ... 1.1
Pick-up	xUs	0.65 ... 0.75	0.45 ... 0.65	0.6 ... 0.8
Seal	xUs	0.4 ... 0.55	0.15 ... 0.3	0.35 ... 0.55
Consumption				
AC	Magnetic circuit closed (VA)	9	-	0.7 - 2.2
	Magnetic circuit open (VA)	76.1	-	48.6 - 47.2
DC	Magnetic circuit closed (W)	-	3.6 - 7.5	0.6 - 0.1
	Magnetic circuit open (W)	-	3.6 - 7.5	3.6 (VA)
Power dissipation	(W)	2.4	3.6 - 7.5	
Power factor				
Magnetic circuit closed	cos φ	0.24	-	-
	cos φ	0.85	-	-
Magnetic circuit open	cos φ	0.85	-	-
	cos φ	0.85	-	-
Opening and closing times				
at 0.8 to 1.1 Us				
Closing time NO	(ms)	6 ... 25	35 ... 65	-
Opening time NO	(ms)	6 ... 13	6 ... 13	-
at Us				
Closing time NO	(ms)	8 ... 20	35 ... 45	25 ... 45
Opening time NO	(ms)	6 ... 13	7 ... 12	50 ... 65
Mechanical endurance				
10 ⁶ ops		10	10	10
Maximum rate no load	ops/h	7200	7200	7200

1) Wide range coil



Built-in auxiliary contacts

		ECAC	ECFA/ECLA
Rated insulation voltage U_i according to IEC 60947	(V)	1000	1000
Rated thermal current I_{th} at $\theta \leq 55^\circ\text{C}$	(A)	10	10
Making capacity (RMS) acc. to IEC 60947			
AC-15 $U_e \leq 400\text{V}$, 50-60Hz	(A)	105	60
DC-13 $U_e \leq 220\text{V DC}$	(A)	105	60
Breaking capacity (RMS) acc. to IEC 60947			
AC-15 $U_e \leq 400\text{V}$, 50-60Hz	(A)	105	60
DC-13 $U_e \leq 220\text{V DC}$	(A)	2	0.95
AC-15 rated voltage and current U_e - I_e according to IEC	(V-A)	110/120-10	110/120-6
		220/230-10	220/230-6
		380/400-6	380/400-4
		415/450-5	415/440-3.5
		500-4	500-2.5
		690/660-2	660/660-1.5
according to UL, CSA		A600	A600
DC-13 rated voltage and current U_e - I_e according to IEC	(V-A)	24-6	24-4
		48-4	48-2
		110-2	110-0.7
		220-0.7	220-0.3
		440-0.35	440-0.15
according to UL, CSA		Q600	Q600
Electrical endurance	10^6 ops.	0.2	0.2
Minimum operational power (operational safety)		17 V - 5mA	10
Short-circuit protection max. fuse class gl-gG without welding	(A)	10	17.5 V-mA
Insulation resistance	Between contacts	(m Ω)	>10
	Between contacts and earth	(m Ω)	10
Guaranteed no overlap between NO and NC contacts			
Space		1.3mm	>10 1.6mm for ECFA / 2.2mm for ECLA
Impedance of the contacts	(m Ω)	2.7	2.7



Auxiliary contactors

ECACA440	ECACA431	ECACA422	ECACA413	ECACA404
ECACD440	ECACD431	ECACD422	ECACD413	ECACD404
ECACE440	ECACE431	ECACE422	ECACE413	ECACE404

--	--	--	--	--



Terminal numbering according to EN 50011

Auxiliary contacts	Description			Possible basic auxiliary contactors + Auxiliary contacts blocks to be added
--------------------	-------------	---	---	---

4NO auxiliary contactor terminal combination with 2P FRONTAL block

	42E	4	2	ECACA440 ECACD440 ECACE440 +ECFA202	
	60E	6	0	ECACA440 ECACD440 ECACE440 +ECFA220	
	51E	5	1	ECACA440 ECACD440 ECACE440 +ECFA211	



4NO auxiliary contactor terminal combination with 4P FRONTAL block

	80E	8	0	ECACA440 ECACD440 ECACE440 +ECFA440	
	44E	4	4	ECACA440 ECACD440 ECACE440 +ECFA440	
	62E	6	2	ECACA440 ECACD440 ECACE440 +ECFA422	
	71E	7	1	ECACA440 ECACD440 ECACE440 +ECFA431	
	53E	5	3	ECACA440 ECACD440 ECACE440 +ECLFA413	







4NO auxiliary contactor terminal combination with LATERAL block mounted on the RIGHT side of the contactor

	42	4	2	ECACA440 ECACD440 ECACE440 +ECLA202	
	51	5	1	ECACA440 ECACD440 ECACE440 +ECLA211	
	60	6	0	ECACA440 ECACD440 ECACE440 +ECLA220	

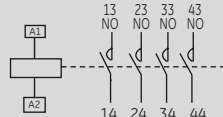
Terminal numbering according to EN 50011 (continued 1)

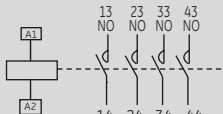
Auxiliary contacts	Description			Possible basic auxiliary contactors + Auxiliary contacts blocks to be added
--------------------	-------------	---	---	---

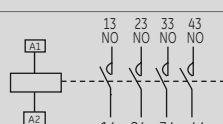







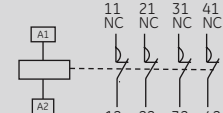

4NO auxiliary contactor terminal combination with LATERAL block mounted on the LEFT side of the contactor

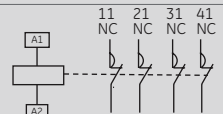
	42	4	2	ECACA440 ECACD440 ECACE440 +ECLA202	
	51	5	1	ECACA440 ECACD440 ECACE440 +ECLA211	
	6	6	0	ECACA440 ECACD440 ECACE440 +ECLA220	

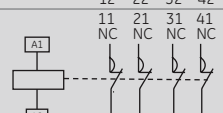

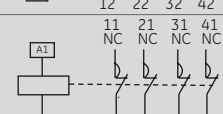
4NC auxiliary contactor terminal combination with 2P FRONTAL block

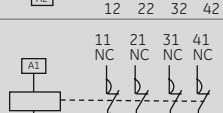
	06E	6	0	ECACA404 ECACD404 ECACE404 +ECFA202	
	24E	2	4	ECACA404 ECACD404 ECACE404 +ECFA220	
	15E	5	1	ECACA404 ECACD404 ECACE404 +ECFA211	







4NC auxiliary contactor terminal combination with 4P FRONTAL block

	44E	4	4	ECACA404 ECACD404 ECACE404 +ECFA440	
	08E	0	8	ECACA404 ECACD404 ECACE404 +ECFA404	
	26E	2	6	ECACA404 ECACD404 ECACE404 +ECFA422	
	35E	3	5	ECACA404 ECACD404 ECACE404 +ECFA431	
	17E	1	7	ECACA404 ECACD404 ECACE404 +ECLFA413	

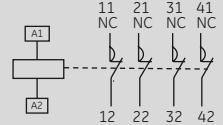

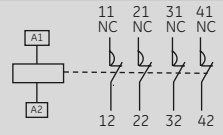

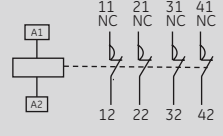

Terminal numbering according to EN 50011 (continued 2)

Auxiliary contacts	Description			Possible basic auxiliary contactors + Auxiliary contacts blocks to be added
		NO	NC	

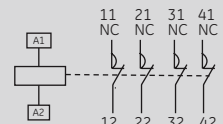
4NC auxiliary contactor terminal combination with LATERAL block mounted on the RIGHT side of the contactor

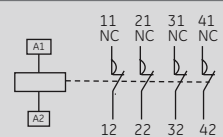
	42	0	6	ECACA404 ECACD404 ECACE404 +ECLA202	
	15	1	5	ECACA404 ECACD404 ECACE404 +ECLA211	
	24	2	4	ECACA404 ECACD404 ECACE404 +ECLA220	

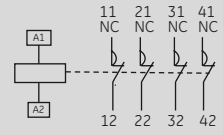
4NC auxiliary contactor terminal combination with LATERAL block mounted on the LEFT side of the contactor

	42	4	2	ECACA440 ECACD440 ECACE440 +ECLA202	
	51	5	1	ECACA440 ECACD440 ECACE440 +ECLA211	
	6	6	0	ECACA440 ECACD440 ECACE440 +ECLA220	

Dimensions and weights

EC contactors

Contactors		
Dimensions in mm	ECACA and ECACE	ECACD
A	92	102
B	66.2	76.2
C	7	7
Weight in g	350	620

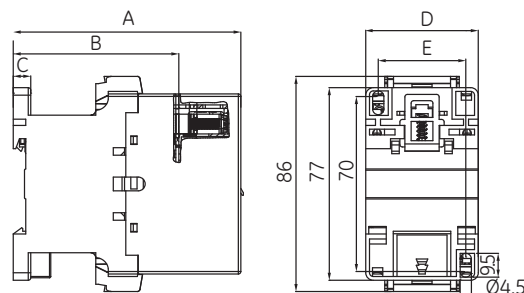

Everything is under control

Surion - Manual motor starter

Order codes

- C.2 **GPS1B - GPS2B** Thermal and magnetic protection
- C.4 **GPS1M - GPS2M** Magnetic protection
- C.6 Auxiliaries
- C.8 Accessories
- C.10 Enclosures

Technical data

- C.12 Technical performance
- C.16 Mounting possibilities of the auxiliaries
- C.18 Dimensions

POWER DEVICES

Contactors and overload relays

Surion

Auxiliary relays and contactors

Manual Motor Starters and Coordination tables

see chapter D pages D.11-D.17

Motor protection devices

SFK - Motor protection circuit breaker

- C.26 Order codes
- C.26 Terminal numbering
- C.26 Technical data
- C.26 Dimensions

AUXILIARY DEVICES

Applications

Main switches

Control and signalling units

POWER ELECTRONICS

Speed drive units

Soft starters

ENCLOSURES

Product overview

Alphabetical index

Intro

A

B

C

D

E

F

G

H

I

X



Thermal and magnetic protection

GPS1B - GPS2B

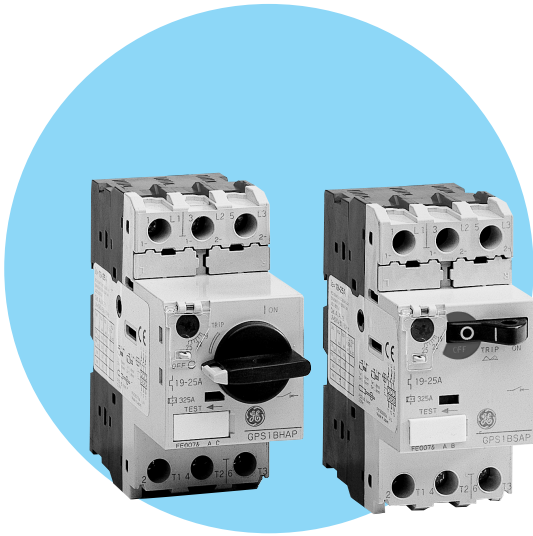

Standards/Approvals

IEC 60947-1, 60947-2, 60947-4-1
 DIN VDE 0660T 100/101/102
 UL508/CSA - UL508/cULus
 Shipping approvals:



RINA



Bureau Veritas



Lloyd's Register
 Germanischer Lloyd



cULus



CE

Characteristics

- Rocker and rotary handle operator (GPS2 only rotary)
- Thermal and magnetic protection
- Standard and high breaking capacity
 $I_{cu} = 100kA \geq I_{cs} = 100\% I_{cu}$
 $I_{cu} < 100kA \geq I_{cs} \text{ min. } 75\% I_{cu}$
- Clear identification of the operation state (ON-OFF-tripped)
- Ambient temperature compensation
- Phase failure protection

Auxiliaries

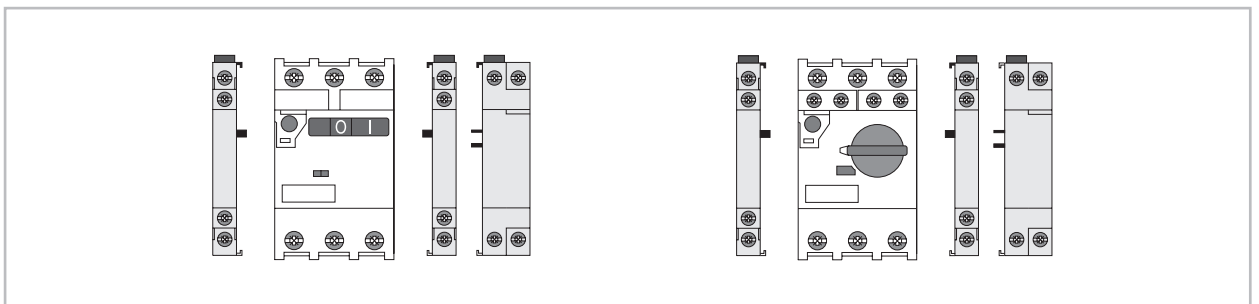

Technical performances

Rated current I_n	(A)	0.1-63
Rated operational current I_e (A)		0.1-63
Rated power at 400V AC	(kW)	0.02-30
Utilisation category		
IEC 60947-2 (circuit breaker)		A
IEC 60947-4-1 (MMS)		AC-3
Tripping class IEC 60947-4-1		10
Magnetic release $I_e \text{ max.}$	(A)	x13
Mechanical/electrical endurance		
GPS1		100,000/100,000
GPS2		50,000/25,000

Accessories

- Auxiliaries ● page C.6
- Busbar system ● page C.9

- Technical data ● page C.12
- Dimensions ● page C.18
- Coordination tables ● page D.11



GPS1B - Rocker Handle

CLASS 10	Rated power 3 phase motors at 400V AC Pn	Rated current In (1)	Thermal current setting range	Instantaneous short-circuit release	Rated ultimate short-circuit breaking capacity at 400V Icu (kA)	Rated service short-circuit breaking capacity at 400V Ics (kA)	Cat. no.	Ref. no.	Pack.
	(kW)	(A)	(A)	(A)					
	0.02	0.16	0.10 - 0.16	2.1	100	100	GPS1BSAA	101211	5
	0.06	0.25	0.16 - 0.25	3.3	100	100	GPS1BSAB	101212	5
	0.09	0.4	0.25 - 0.40	5.2	100	100	GPS1BSAC	101213	5
	0.12/0.18	0.63	0.40 - 0.63	8.2	100	100	GPS1BSAD	101214	5
	0.25	1	0.63 - 1.00	13	100	100	GPS1BSAE	101215	5
	0.37/0.55	1.6	1.0 - 1.6	20.8	100	100	GPS1BSAF	101216	5
	0.75	2.5	1.6 - 2.5	32.5	100	100	GPS1BSAG	101217	5
	1.5	4	2.5 - 4.0	52	100	100	GPS1BSAH	101218	5
	2.2	6.3	4.0 - 6.3	81.9	100	100	GPS1BSAJ	101219	5
	3/4	10	6.3 - 10	130	100	100	GPS1BSAK	101220	5
	5.5	13	9 - 13	169	50	38	GPS1BSAL	101221	5
	7.5	16	11 - 16	208	25	19	GPS1BSAM	101222	5
	10	20	14 - 20	260	25	19	GPS1BSAN	101223	5
	11	25	19 - 25	325	25	19	GPS1BSAP	101224	5
	15	32	24 - 32	416	25	19	GPS1BSAR	101225	5



(1) Rated current: highest thermal current setting range value.

GPS1B - High breaking capacity.

CLASS 10	Rated power 3 phase motors at 400V AC Pn	Rated current In (1)	Thermal current setting range	Instantaneous short-circuit release	Rated ultimate short-circuit breaking capacity at 400V Icu (kA)	Rated service short-circuit breaking capacity at 400V Ics (kA)	Cat. no.	Ref. no.	Pack.
	(kW)	(A)	(A)	(A)					
	0.02	0.16	0.10 - 0.16	2.1	100	100	GPS1BHAA	101234	5
	0.06	0.25	0.16 - 0.25	3.3	100	100	GPS1BHAB	101235	5
	0.09	0.4	0.25 - 0.40	5.2	100	100	GPS1BHAC	101236	5
	0.12/0.18	0.63	0.40 - 0.63	8.2	100	100	GPS1BHAD	101237	5
	0.25	1	0.63 - 1.00	13	100	100	GPS1BHAE	101238	5
	0.37/0.55	1.6	1 - 1.6	20.8	100	100	GPS1BHAF	101239	5
	0.75	2.5	1.6 - 2.5	32.5	100	100	GPS1BHAG	101240	5
	1.5	4	2.5 - 4.0	52	100	100	GPS1BHAH	101241	5
	2.2	6.3	4.0 - 6.3	81.9	100	100	GPS1BHAJ	101242	5
	3/4	10	6.3 - 10	130	100	100	GPS1BHAK	101243	5
	5.5	13	9 - 13	169	100	100	GPS1BHAL	101244	5
	7.5	16	11 - 16	208	50	38	GPS1BHAM	101245	5
	10	20	14 - 20	260	50	38	GPS1BHAN	101246	5
	11	25	19 - 25	325	50	38	GPS1BHAP	101247	5
	15	32	24 - 32	416	50	38	GPS1BHAR	101248	5



(1) Rated current: highest thermal current setting range value.

GPS2B - High breaking capacity

CLASS 10	Rated power 3 phase motors at 400V AC Pn	Rated current In (1)	Thermal current setting range	Instantaneous short-circuit release	Short-circuit breaking capacity at 400V Icu (kA)	Short-circuit breaking capacity at 400V Ics (kA)	Cat. no.	Ref. no.	Pack.
	(kW)	(A)	(A)	(A)					
	3/4	10	6.3 - 10	130	100	100	GPS2BHAK	101249	1
	5.5	13	9 - 13	169	100	100	GPS2BHAL	107120	1
	7.5	16	11 - 16	208	50	38	GPS2BHAM	101250	1
	10	20	14 - 20	260	50	38	GPS2BHAN	101251	1
	11	25	19 - 25	325	50	38	GPS2BHAP	101252	1
	15	32	24 - 32	416	50	38	GPS2BHAR	101253	1
	18.5	40	28 - 40	520	50	38	GPS2BHAS	101254	1
	22	50	35 - 50	650	50	38	GPS2BHAT	101255	1
	30	63	45 - 63	819	50	38	GPS2BHAU	101256	1



(1) Rated current: highest thermal current setting range value.

Magnetic protection

GPS1M - GPS2M

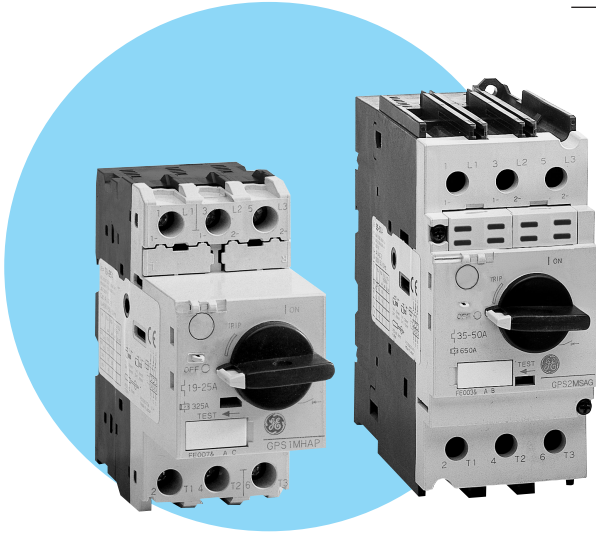

Standards/Approvals

IEC 60947-1, 60947-2, 60947-4-1
 DIN VDE 0660T 100/101/102
 UL508/CSA - UL508/cULus
 Shipping approvals:



RINA



Bureau Veritas



Lloyd's Register
 Germanischer Lloyd



cULus



CE

Characteristics

- Short-circuit protection for starters
- Rocker and rotary handle operator (GPS2 only rotary)
- Magnetic protection
- Standard and high breaking capacity
 $I_{cu} = 100kA \geq I_{cs} = 100\% I_{cu}$
 $I_{cu} < 100kA \geq I_{cs} \text{ min. } 75\% I_{cu}$
- Clear identification of the operation state (ON-OFF-tripped)

Auxiliaries

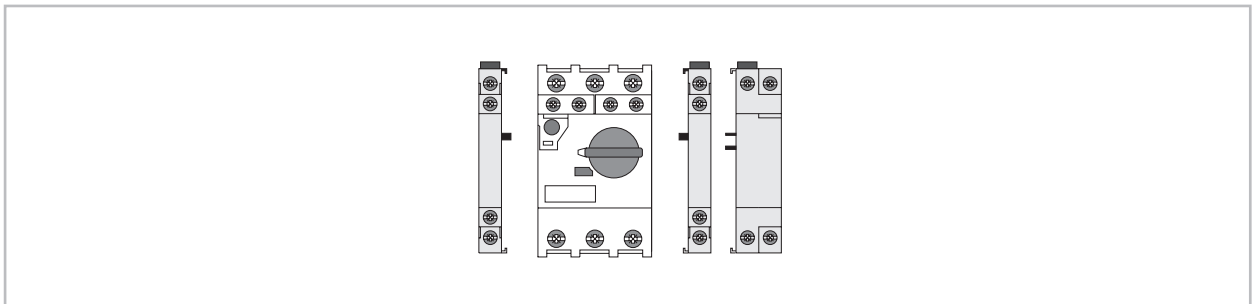

Technical performances

Rated current I_n	(A)	0.1-63
Rated operational current I_e	(A)	0.1-63
Utilisation category		A
IEC 60947-2 (circuit breaker)		A
Magnetic release $I_e \text{ max.}$	(A)	x13
Mechanical/electrical endurance		
GPS1		100,000/100,000
GPS2		50,000/25,000

Accessories

- Auxiliaries ● page C.6
- Busbar system ● page C.9

- Technical data ● page C.12
- Dimensions ● page C.18
- Coordination tables ● page D.11



GPS1M - High breaking capacity



Rated power 3 phase motors at 400V AC Pn (kW)	Rated current In (A)	Thermal current setting range (1) (A)	Instantaneous short-circuit release (A)	Rated ultimate short-circuit breaking capacity at 400V Icu (kA)	Rated service short-circuit breaking capacity at 400V Ics (kA)	Cat. no.	Ref. no.	Pack.
0.02	0.16	-	2.1	100	100	GPS1MHAA	101280	5
0.06	0.25	-	3.3	100	100	GPS1MHAB	101281	5
0.09	0.4	-	5.2	100	100	GPS1MHAC	101282	5
0.12/0.18	0.63	-	8.2	100	100	GPS1MHAD	101283	5
0.25	1	-	13	100	100	GPS1MHA E	101284	5
0.37/0.55	1.6	-	20.8	100	100	GPS1MHA F	101285	5
0.75	2.5	-	32.5	100	100	GPS1MHA G	101286	5
1.5	4	-	52	100	100	GPS1MHA H	101287	5
2.2	6.3	-	81.9	100	100	GPS1MHA J	101288	5
3/4	10	-	130	100	100	GPS1MHA K	101289	5
5.5	13	-	169	100	100	GPS1MHA L	101290	5
7.5	16	-	208	50	38	GPS1MHA M	101291	5
10	20	-	260	50	38	GPS1MHA N	101292	5
11	25	-	325	50	38	GPS1MHA P	101293	5
15	32	-	416	50	38	GPS1MHA R	101294	5

(1) Select appropriate thermal overload relay for the starter. See chapter A pages A.56 - A.61.

GPS2M - High breaking capacity



Rated power 3 phase motors at 400V AC Pn (kW)	Rated current In (A)	Thermal current setting range (1) (A)	Instantaneous short-circuit release (A)	Rated ultimate short-circuit breaking capacity at 400V Icu (kA)	Rated service short-circuit breaking capacity at 400V Ics (kA)	Cat. no.	Ref. no.	Pack.
4	10	-	130	100	100	GPS2MHAK	101295	1
5.5	13	-	169	100	100	GPS2MHAL	107122	1
7.5	16	-	208	50	38	GPS2MHAM	101296	1
10	20	-	260	50	38	GPS2MHAN	101297	1
11	25	-	325	50	38	GPS2MHAP	101298	1
15	32	-	416	50	38	GPS2MHAR	101299	1
18.5	40	-	520	50	38	GPS2MHAS	101300	1
22	50	-	650	50	38	GPS2MHAT	101301	1
30	63	-	819	50	38	GPS2MHAU	101302	1

(1) Select appropriate thermal overload relay for the starter. See chapter A pages A.56 - A.61.



Auxiliaries

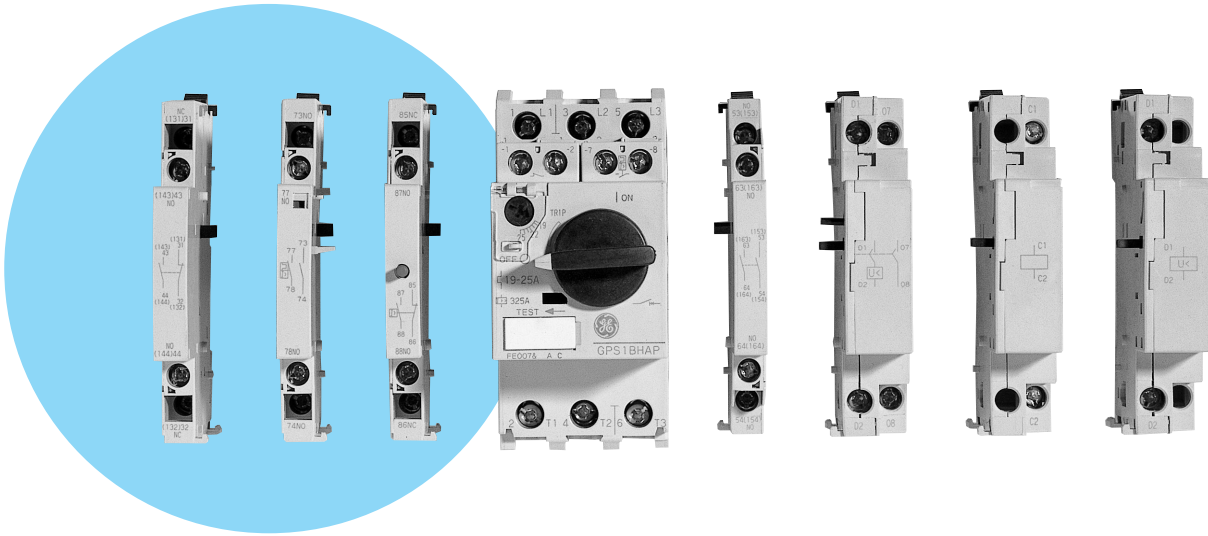

Standards/Approvals

IEC 60947-1, 60947-2, 60947-4-1
 DIN VDE 0660T 100/101/102
 UL508/CSA - UL508/cULus
 Shipping approvals:



RINA



Bureau Veritas



Lloyd's Register
 Germanischer Lloyd



cULus



CE

Product range

- Auxiliary contacts (frontal & lateral)
- Alarm contact block
- Auxiliary and alarm contact block
- Short-circuit alarm contact block
- Shunt trip
- Undervoltage release
- Undervoltage release with 2NO early make contacts
- External handle operator
- Terminal protector
- Busbar system

Auxiliaries

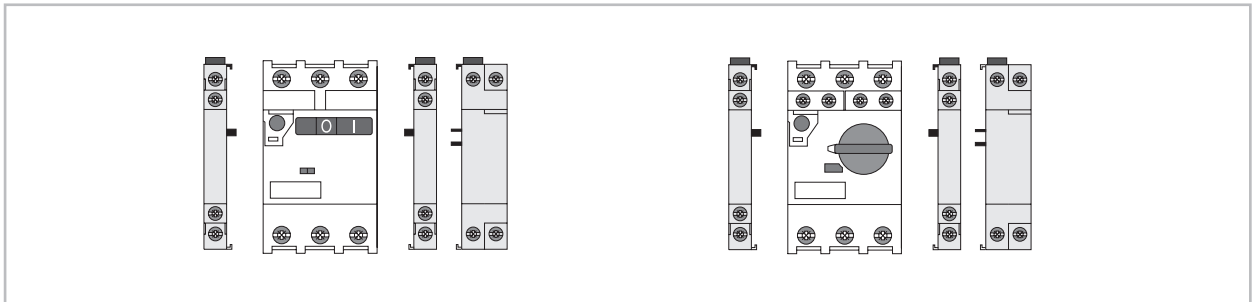

Technical performances

- All auxiliaries can be mounted and changed easily, without any tools
- Both frames GPS1 and GPS2 uses same auxiliaries
- All terminals are capable for 2 cables (0.5mm² - 2.5mm²)
- Side auxiliary contacts are rated to A600, P300 duty
- Frontal auxiliary contacts are rated to B300, Q300 duty
- Minimum operational contact 5mA, 17V DC
- All terminal screwhead are Pozidriv 2 and slotted combination

Technical data ● page C.12
 Dimensions ● page C.18
 Coordination tables ● page D.11

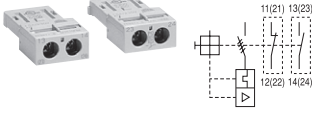
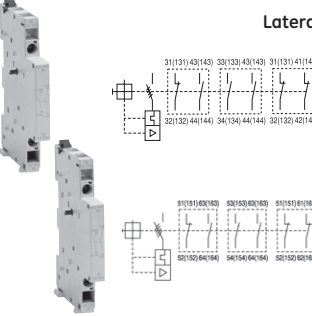

Auxiliary contact blocks

	Description	For use with	Type	Cat. no.	Ref. no.	Pack.
Frontal 	Maximum 2 auxiliary contact blocks per manual motor starter	GPS1... and GPS2...	1 NO	GPAC10FBA	101303	10
		GPS1... and GPS2...	1 NC	GPAC01FBA	101304	10
Lateral 	Two contacts Side mounting on the left	GPS1... and GPS2...	1 NO + 1 NC	GPAC11LLA	101305	10
		GPS1... and GPS2...	2 NO	GPAC20LLA	101306	10
		GPS1... and GPS2...	2 NC	GPAC02LLA	101307	10
	Two contacts Side mounting on the right	GPS1... and GPS2...	1 NO + 1 NC	GPAC11LRA	101308	10
		GPS1... and GPS2...	2 NO	GPAC20LRA	101309	10
		GPS1... and GPS2...	2 NC	GPAC02LRA	101310	10

Alarm contact block

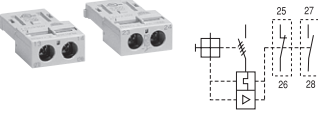
	Description	For use with	Type	Cat. no.	Ref. no.	Pack.
	Frontal mounting on the right Single contact	GPS1... and GPS2...	1 NO	GPAL10FRA	101311	10
		GPS1... and GPS2...	1 NC	GPAL01FRA	101312	10

Auxiliary / alarm contact block

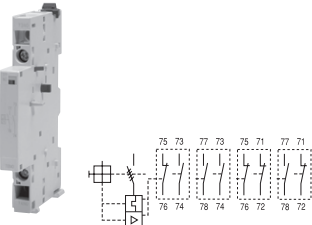
	Description	For use with ⁽¹⁾	Type	Cat. no.	Ref. no.	Pack.
	Side mounting on the left	GPS1... and GPS2...	1 NO(Alarm)+1 NO(Aux)	GPAD1010LLA	101313	10
		GPS1... and GPS2...	1 NO(Alarm)+1 NC(Aux)	GPAD1001LLA	101314	10
	Two contacts	GPS1... and GPS2...	1 NC(Alarm)+1 NO(Aux)	GPAD0110LLA	101315	10
		GPS1... and GPS2...	1 NC(Alarm)+1 NC(Aux)	GPAD0101LLA	101316	10

Short-circuit alarm contact block

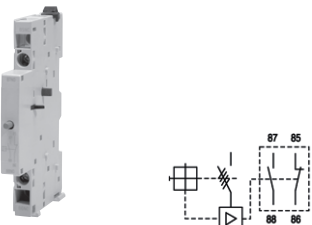
	Description	For use with	Type	Cat. no.	Ref. no.	Pack.
	Side mounting on the left Two contacts NO + NC Mechanical indication marking	GPS1... and GPS2...	1 NO + 1 NC	GPAE11LLA	101317	10

(1) If an alarm contact block is used together with an undervoltage trip device, the alarm contact block will not operate correctly when the MMS is automatically tripped due to undervoltage.

Shunt trip device

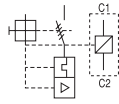

Description	For use with	Coil voltage	Cat. no.	Ref. no.	Pack.
Side mounting on the right Can not be used together with the undervoltage trip device	GPS1... and GPS2...	24V 50/60Hz	GPASLRAA1	101318	5
	GPS1... and GPS2...	48V 60Hz	GPASLRAAF	101319	5
	GPS1... and GPS2...	48V 50Hz / 60V 60Hz	GPASLRAAG	101320	5
	GPS1... and GPS2...	110/127V 50Hz / 120V 60Hz	GPASLRAAJ	101321	5
	GPS1... and GPS2...	208V 60Hz	GPASLRAAM	101322	5
	GPS1... and GPS2...	220/230V 50Hz / 240/260V 60Hz	GPASLRAAN	101323	5
	GPS1... and GPS2...	240V 50Hz / 277V 60Hz	GPASLRAAR	101324	5
	GPS1... and GPS2...	380/400V 50Hz	GPASLRAAU	101325	5
	GPS1... and GPS2...	415/440V 50Hz / 460/480V 60Hz	GPASLRAAW	101326	5
	GPS1... and GPS2...	500V 50Hz / 600V 60Hz	GPASLRAAY	101327	5
	GPS1... and GPS2...	24 to 60V DC	GPASLRADD	101328	5
	GPS1... and GPS2...	110 to 240V DC	GPASLRADJ	101329	5
	GPS1... and GPS2...	100V 50/60Hz	GPASLRAA11	101194	5

Undervoltage trip device

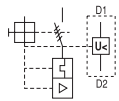

Description	For use with	Coil voltage	Cat. no.	Ref. no.	Pack.
Side mounting on the right Can not be used together with the shunt trip device	GPS1... and GPS2...	24V 50Hz	GPAULRAAD	101330	10
	GPS1... and GPS2...	24V 60Hz	GPAULRAAC	101331	10
	GPS1... and GPS2...	48V 50Hz	GPAULRAAG	101332	10
	GPS1... and GPS2...	48V 60Hz	GPAULRAAF	101333	10
	GPS1... and GPS2...	110/127V 50Hz / 120V 60Hz	GPAULRAAJ	101334	10
	GPS1... and GPS2...	208V 60Hz	GPAULRAAM	101335	10
	GPS1... and GPS2...	220/230V 50Hz / 240/260V 60Hz	GPAULRAAN	101336	10
	GPS1... and GPS2...	240V 50Hz / 277V 60Hz	GPAULRAAR	101337	10
	GPS1... and GPS2...	380/400V 50Hz	GPAULRAAU	101338	10
	GPS1... and GPS2...	415/440V 50Hz / 460/480V 60Hz	GPAULRAAW	101339	10
	GPS1... and GPS2...	500V 50Hz / 600V 60Hz	GPAULRAAY	101340	10
	GPS1... and GPS2...	100V 50/60Hz	GPAULRAA11	102625	10

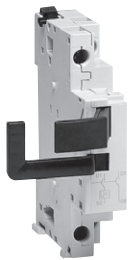

With 2NO early make auxiliary contacts

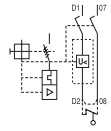

Description	For use with	Coil voltage	Cat. no.	Ref. no.	Pack.
Side mounting on the right Can not be used together with the shunt trip device	GPS1... S...	24V 50Hz	GPAU20LTAAD	101341	10
	GPS1... S...	24V 60Hz	GPAU20LTAAC	101342	10
	GPS1... S...	48V 50Hz	GPAU20LTAAG	101343	10
	GPS1... S...	48V 60Hz	GPAU20LTAAF	101344	10
	GPS1... S...	110/127V 50Hz / 120V 60Hz	GPAU20LTAAJ	101345	10
	GPS1... S...	208V 60Hz	GPAU20LTAAM	101346	10
	GPS1... S...	220/230V 50Hz / 240/260V 60Hz	GPAU20LTAAN	101347	10
	GPS1... S...	240V 50Hz / 277V 60Hz	GPAU20LTAAR	101348	10
	GPS1... S...	380/400V 50Hz	GPAU20LTAAU	101349	10
	GPS1... S...	415/440V 50Hz / 460/480V 60Hz	GPAU20LTAAW	101350	10
	GPS1... S...	500V 50Hz / 600V 60Hz	GPAU20LTAAY	101351	10
	GPS1... S...	100V 50/60Hz	GPAU20LTA11	110360	10



With 2NO early make auxiliary contacts

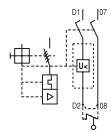

Description	For use with	Coil voltage	Cat. no.	Ref. no.	Pack.
Side mounting on the right Can not be used together with the shunt trip device	GPS1... H and GPS2...	24V 50Hz	GPAU20LCAAD	101352	10
	GPS1... H and GPS2...	24V 60Hz	GPAU20LCAAC	101353	10
	GPS1... H and GPS2...	48V 50Hz	GPAU20LCAAG	101354	10
	GPS1... H and GPS2...	48V 60Hz	GPAU20LCAAF	101355	10
	GPS1... H and GPS2...	110/127V 50Hz / 120V 60Hz	GPAU20LCAAJ	101356	10
	GPS1... H and GPS2...	208V 60Hz	GPAU20LCAAM	101357	10
	GPS1... H and GPS2...	220/230V 50Hz / 240/260V 60Hz	GPAU20LCAAN	101358	10
	GPS1... H and GPS2...	240V 50Hz / 277V 60Hz	GPAU20LCAAR	101359	10
	GPS1... H and GPS2...	380/400V 50Hz	GPAU20LCAAU	101360	10
	GPS1... H and GPS2...	415/440V 50Hz / 460/480V 60Hz	GPAU20LCAAW	101361	10
	GPS1... H and GPS2...	500V 50Hz / 600V 60Hz	GPAU20LCAAY	101362	10
	GPS1... H and GPS2...	100V 50/60Hz	GPAU20LCA11	112185	10

Terminal protector



101509



107182



Description	For use with	Cat. no.	Ref. no.	Pack.
Snap-in tabs for screw mounting (set of 10)	GPS1...	GPAKS1A	101509	1
IP20 terminal covers	GPS2...	GPAPT2A	107182	50
DIN rail vibration clamps	GPS1... / GPS2...	GPVDA	101514	2
Panel vibration clamps	GPS1... / GPS2...	GPVPA	101515	2
Increases vibration resistance of GPS1* from 5G to 8G (5-150Hz) in all directions. One clamp must be mounted on each side which increases total mounting width by 22mm (0.87"). For vibration resistance of GPS2*, contact customer service.				



External handle operator

	Description	For use with	Type	Cat. no.	Ref. no.	Pack.
	Used for distance mounting on a panel Lockable with 1, 2 or 3 padlocks diameter 4 to 8mm Two types: standard and emergency applications ON/OFF/TRIPPING position marking Protection degree: IP54 Shaft mounting depths: 139.8 - 289.8mm for GPA1HAB, GPA1HAR 161 - 311.1mm for GPA2HAB, GPA2HAR Package parts and quantities: 1 handle unit 1 shaft 1 shaft guide 1 latch (screws) 4 mounting screws	GPS1_H...	Standard (black)	GPA1HAB	101363	5
		GPS1_H ...	Emergency (red/yellow)	GPA1HAR	101364	5
		GPS2...	Standard (black)	GPA2HAB	101502	5
		GPS2 ...	Emergency (red/yellow)	GPA2HAR	101503	5

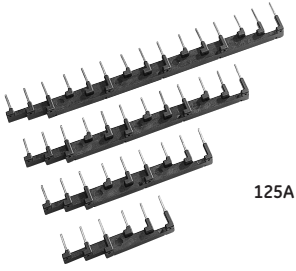
Busbar system

	Description	For use with	Connection	Cat. no.	Ref. no.	Pack.		
	3-phase feed-in terminals	GPS1...	Terminal capacity: 25mm ² Pin	GPB1FA	107186	10		
		GPS2...	Terminal capacity: 50mm ² Pin	GPB2FA	107187	10		
		GPS1...	Terminal capacity: 25mm ² Fork	SFVB8	254537	1		
	Main busbar 63A max.	Modular spacing 45mm	for 2 GPS1... + frontal auxiliaries for 3 GPS1... + frontal auxiliaries for 4 GPS1... + frontal auxiliaries for 5 GPS1... + frontal auxiliaries	Pin Pin Pin Pin	GPB1B02A GPB1B03A GPB1B04A GPB1B05A	101390 101391 101392 101393	5 5 5 5	
		Modular spacing 54mm	for 2 GPS1... + 9mm lateral aux. for 3 GPS1... + 9mm lateral aux. for 4 GPS1... + 9mm lateral aux. for 5 GPS1... + 9mm lateral aux.	Pin Pin Pin Pin	GPB1B12A GPB1B13A GPB1B14A GPB1B15A	101394 101395 101396 101397	5 5 5 5	
		Modular spacing 63mm	for 2 GPS1... + 18mm lateral aux. or 2x9mm lateral auxiliary for 4 GPS1... + 18mm lateral aux. or 2x9mm lateral auxiliary	Fork Fork	GPB1B22A GPB1B24A	101398 101399	10 10	
		Modular spacing 55mm	for 2 GPS2... + frontal auxiliaries for 3 GPS2... + frontal auxiliaries for 4 GPS2... + frontal auxiliaries	Pin Pin Pin	GPB2B02A GPB2B03A GPB2B04A	101400 101401 101402	1 1 1	
		Modular spacing 64mm	for 2 GPS2... + 9mm lateral aux. for 3 GPS2... + 9mm lateral aux. for 4 GPS2... + 9mm lateral aux.	Pin Pin Pin	GPB2B12A GPB2B13A GPB2B14A	101403 101404 101405	1 1 1	
		Modular spacing 73mm	for 2 GPS2... + 18mm lateral aux. or 2x9mm lateral auxiliary for 4 GPS2... + 18mm lateral aux. or 2x9mm lateral auxiliary	Pin Pin	GPB2B22A GPB2B24A	101406 101407	1 1	
			Busbar cover	GPS1...	Pin	GPB1GA	101408	10
				GPS2...	Pin	GPB2GA	101409	10
			Terminal cover Type E	For compliance UL508E GPS1	-	GPAPT1E	107315	1

When using a Surion GPS1 as a manual self-protected combination motor starter (Type E).
Cover enables compliance with NEC Section 430-52, 1" over air creepage and over surface clearance, phase to phase on the line side.

Order codes

Intro

A

B

C

D

E

F

G

H

I

X



Enclosures for manual motor starters



Product range

- Surface and flush mounting plastic enclosures (IP41 and IP55)
- Neutral and ground connection
- Three different types of push-buttons
 - Mushroom with impulse function
 - Mushroom self latching, unlatching by turning
 - Mushroom self latching, unlatching with a key
- Indicator lamps
- Padlocking device for three padlocks
- Conversion kit IP41 to IP55

Technical performances

- Used with GPS1_S manual motor starters
- Protection degree IP41 or IP55
- Possibility to mount frontal/lateral auxiliary contact blocks with an undervoltage release (without or with 2NO early make auxiliary contacts) inside the enclosures

Manual motor starter







- GPS1B ● page C.2
- GPS2B ● page C.2
- GPS1M ● page C.4
- GPS2M ● page C.4



Enclosures for only GPS 1_S

	Description	Cat. no.	Ref. no.	Pack.
	Surface mounting IP41	GPE41A	101365	1
	Surface mounting IP55	GPE55A	101366	1
	Flush mounting IP41	GPEF41A	101367	1
	Flush mounting IP55	GPEF55A	101368	1

Mounting accessories for all enclosures

	Description	Cat. no.	Ref. no.	Pack.
	Neutral connection To be used inside the enclosure	GPENA	101369	1
	Adaptor set For enclosures used with GPS1_S and undervoltage release with 2 NO auxiliary contacts	GPEUTA	107097	1
	Padlocking device For three padlocks with max. 8mm shackle diameter Not to be used with emergency stop handle	GPEPA	101370	1
	Conversion kit IP41 to IP55	GPECA	101371	1
	Mushroom spring return	GPEPMA	101372	1
	Mushroom self latching, turn to release	GPEPLA	101373	1
	Mushroom self latching, release with a key	GPEPKA	101374	1
	Green 110/120V	GPELGAJ	101375	1
	Green 220/240V	GPELGAN	101376	1
	Green 380/440V	GPELGAU	101377	1
	Green 480/500V	GPELGAX	101378	1
	Green 600V	GPELGAY	101379	1
	Red 110/120V	GPELRAJ	101380	1
	Red 220/240V	GPELRAN	101381	1
	Red 380/440V	GPELRAU	101382	1
	Red 480/500V	GPELRAX	101383	1
	Red 600V	GPELRAY	101384	1
	Transparent 110/120V	GPELCAJ	101385	1
	Transparent 220/240V	GPELCAN	101386	1
	Transparent 380/440V	GPELCAU	101387	1
	Transparent 480/500V	GPELCAX	101388	1
Transparent 600V	GPELCAY	101389	1	

Technical data

General data

Frame size	GPS1	GPS2
Rated insulation voltage Ui	690V	1000V
Rated operating voltage Ue	690V AC	690V AC
Rated impulse withstand strength Uimp	6kV	8kV
Rated frequency	50/60Hz	50/60Hz
Total power loss P (W)	0.16 to 25A 7W 32A 8.5W	up to 32A 11W 40A to 50A 15W 63A 17W
Utilisation category: IEC 947-2 (Circuit breaker) IEC 947-4-1 (Motor starter)	Cat. A AC3	Cat. A AC3
Mechanical operational performance	100,000 (70,000 for 32A)	50,000
Electrical operational performance	100,000 (70,000 for 32A)	25,000
Max. operations per hour (motor start-up)	25	25
Ambient conditions: Storage temperature	-40°C to +80°C	-40°C to +80°C
Operation temperature	-25°C to +60°C	-25°C to +60°C
Temperature compensation	-20°C to +60°C	-20°C to +60°C
Ambient temperature compensation	yes	yes
Operational altitude	up to 2000m	up to 2000m
Shock resistance (IEC 68)	30g (width 20ms)	30g (width 20ms)
Vibration resistance	8g (5 to 150Hz)	8g (5 to 150Hz)
Shock -hazard prot. (acc.DIN VDE 0106) Protection degree (acc.to IEC529)	fingerproof IP20	fingerproof IP10 (IP20 with acc GPAPT2A)
Rated current Ie	up to 32A	up to 63A
Overload protection	IEC 947-4-1	IEC 947-4-1
Phase failure protection	yes	yes
Tripping class	10	10
Magnetic release (factory set)	13x lemax	13x lemax
Test trip button	yes	yes
Standards & Approvals		
IEC 947-1 / -2 / -4-1	yes	yes
DIN VDE 0660T 100 / 101 / 102	yes	yes
UL508	yes	yes
UL508 type E	Only GPS1_H	yes
CE	yes	yes
cULus	yes	yes
D / S / N / Fi	In process	-
Shipping approvals	yes	yes

Mounting data

Terminal capacity: Solid or stranded without end sleeve	1x1...10mm ² 2x1...6mm ²	1 or 2x1...25mm ²
Stranded with end sleeve AWG	1 or 2x1...6mm ² 1x18...8 / 2x18...10	1x1...25mm ² / 2x1...16mm ² 1x18...2 / 2x18...4
Operating mechanism lockable in OFF position diameter (mm)	3.5 to 4.5	3.5 to 4.5
Terminal type	screw	box
Tightening torque	2 Nm / 18Lb.in	5 Nm / 45 Lb.in
Screwdriver	Pz2 / slotted combination	Pz2 / slotted combination
Mounting: DIN-rail	yes	yes
Screws	no	yes
Operating position: turning to the front	30°	30°
turning to the back	90°	90°
turning to both sides	180°	180°
Handle operation	Rocker level / Rotary	Rotary
Dimensions width (mm)	45	55
height (mm)	90	120
depth (mm)	(GPS1_S) 75 / 92.5 (GPS1_H)	107.5



Ultimate short-circuit breaking capacity (Icu) in kA

		For ranges GPS1BSA_ / GPS1MSA_																	
Rated current (A)		A	B	C	D	E	F	G	H	J	K	L	M	N	P	R	S	T	U
		1.6	0.25	0.4	0.63	1	1.6	2.5	4	6.3	10	13	16	20	25	32	40	50	63
220/230V		100	100	100	100	100	100	100	100	100	100	100	100	50	50	50	-	-	-
400/415V		100	100	100	100	100	100	100	100	100	100	50	25	25	25	25	-	-	-
440V		100	100	100	100	100	100	100	50	15	10	10	10	10	10	10	-	-	-
500/525V		100	100	100	100	100	100	100	50	10	6	6	6	6	6	6	-	-	-
600V		100	100	100	100	100	3	3	3	3	3	3	3	3	3	3	-	-	-
690V		100	100	100	100	100	3	3	3	3	3	3	3	3	3	3	-	-	-
		For ranges GPS1BHA_ / GPS1MHA_																	
220/230V		100	100	100	100	100	100	100	100	100	100	100	100	100	100	100	-	-	-
400/415V		100	100	100	100	100	100	100	100	100	100	50	50	50	50	50	-	-	-
440V		100	100	100	100	100	100	100	100	50	50	35	35	35	35	-	-	-	
500/525V		100	100	100	100	100	100	100	100	50	42	10	10	10	10	-	-	-	
600V		100	100	100	100	100	8	8	6	6	6	4	4	4	4	-	-	-	
690V		100	100	100	100	100	8	8	6	6	6	4	4	4	4	-	-	-	
		For ranges GPS2BSA_ / GPS2MSA_																	
220/230V		-	-	-	-	-	-	-	-	-	100	100	100	50	50	50	50	50	50
400/415V		-	-	-	-	-	-	-	-	-	100	50	25	25	25	25	25	25	25
440V		-	-	-	-	-	-	-	-	-	15	10	10	10	10	10	10	10	10
500/525V		-	-	-	-	-	-	-	-	-	10	6	6	6	6	6	5	5	5
600V		-	-	-	-	-	-	-	-	-	4	4	4	4	4	4	4	4	4
690V		-	-	-	-	-	-	-	-	-	4	4	4	4	4	4	4	4	4
		For ranges GPS2BHA_ / GPS2MHA_																	
220/230V		-	-	-	-	-	-	-	-	-	100	100	100	100	100	100	100	100	100
400/415V		-	-	-	-	-	-	-	-	-	100	100	50	50	50	50	50	50	50
440V		-	-	-	-	-	-	-	-	-	50	50	50	50	35	35	35	35	35
500/525V		-	-	-	-	-	-	-	-	-	50	42	12	12	12	10	10	10	10
600V		-	-	-	-	-	-	-	-	-	6	6	5	5	5	5	5	5	5
690V		-	-	-	-	-	-	-	-	-	6	6	5	5	5	5	5	5	5

Short-circuit proof with an Icu = 100kA or 50kA

Rated service short-circuit breaking capacity (Ics) in kA

		For ranges GPS1BSA_ / GPS1MSA_																	
Rated current (A)		A	B	C	D	E	F	G	H	J	K	L	M	N	P	R	S	T	U
		1.6	0.25	0.4	0.63	1	1.6	2.5	4	6.3	10	13	16	20	25	32	40	50	63
220/230V		100	100	100	100	100	100	100	100	100	100	100	100	38	38	38	-	-	-
400/415V		100	100	100	100	100	100	100	100	100	100	38	19	19	19	19	-	-	-
440V		100	100	100	100	100	100	100	100	38	11	8	8	8	8	8	-	-	-
500/525V		100	100	100	100	100	100	100	100	38	8	5	5	5	5	5	-	-	-
600V		100	100	100	100	100	2	2	2	2	2	2	2	2	2	2	-	-	-
690V		100	100	100	100	100	2	2	2	2	2	2	2	2	2	2	-	-	-
		For ranges GPS1BHA_ / GPS1MHA_																	
220/230V		100	100	100	100	100	100	100	100	100	100	100	100	100	100	100	-	-	-
400/415V		100	100	100	100	100	100	100	100	100	100	38	38	25	25	25	-	-	-
440V		100	100	100	100	100	100	100	100	38	38	25	25	25	25	-	-	-	
500/525V		100	100	100	100	100	100	100	100	38	32	8	8	8	8	-	-	-	
600V		100	100	100	100	100	6	6	5	5	5	3	3	3	3	-	-	-	
690V		100	100	100	100	100	6	6	5	5	5	3	3	3	3	-	-	-	
		For ranges GPS2BSA_ / GPS2MSA_																	
220/230V		-	-	-	-	-	-	-	-	-	100	100	100	38	38	38	38	38	38
400/415V		-	-	-	-	-	-	-	-	-	100	32	19	19	19	19	19	19	19
440V		-	-	-	-	-	-	-	-	-	12	8	8	8	8	8	8	8	8
500/525V		-	-	-	-	-	-	-	-	-	8	5	5	5	5	5	4	4	4
600V		-	-	-	-	-	-	-	-	-	3	3	3	3	3	3	3	3	3
690V		-	-	-	-	-	-	-	-	-	3	3	3	3	3	3	3	3	3
		For ranges GPS2BHA_ / GPS2MHA_																	
220/230V		-	-	-	-	-	-	-	-	-	100	100	100	100	100	100	100	100	100
400/415V		-	-	-	-	-	-	-	-	-	100	100	38	38	38	38	38	38	38
440V		-	-	-	-	-	-	-	-	-	38	38	38	38	25	25	25	25	25
500/525V		-	-	-	-	-	-	-	-	-	38	32	9	9	9	8	8	8	8
600V		-	-	-	-	-	-	-	-	-	5	5	4	4	4	4	4	4	4
690V		-	-	-	-	-	-	-	-	-	5	5	4	4	4	4	4	4	4

Back-up fuses are necessary in case of possibility of a short-circuit current higher than 100kA or 50kA at the installation point of the device (on request)
 Ics = 100% Icu when Icu = 100kA
 Ics = 75% Icu when Icu < 100kA



Back-up gl/gG fuses only if $I_{cs} > I_{cu}$ (kA)

		For ranges GPS1BSA_ / GPS1MSA_																		
gl/gG fuses (A)		A	B	C	D	E	F	G	H	J	K	L	M	N	P	R	S	T	U	
		1.6	0.25	0.4	0.63	1	1.6	2.5	4	6.3	10	13	16	20	25	32	40	50	63	
230V	#	#	#	#	#	#	#	#	#	#	#	#	#	100	100	100	-	-	-	
400V	#	#	#	#	#	#	#	#	#	#	#	80	100	100	100	100	-	-	-	
440V	#	#	#	#	#	#	#	#	#	50	63	63	80	80	80	80	-	-	-	
500V	#	#	#	#	#	#	#	#	#	50	50	63	63	63	80	80	-	-	-	
600V	#	#	#	#	#	#	#	20	32	40	50	63	63	63	80	80	-	-	-	
690V	#	#	#	#	#	#	#	20	32	40	50	50	63	63	63	63	-	-	-	
		For ranges GPS1BHA_ / GPS1MHA_																		
230V	#	#	#	#	#	#	#	#	#	#	#	#	#	#	#	#	#	-	-	-
400V	#	#	#	#	#	#	#	#	#	#	#	#	100	125	125	125	-	-	-	
440V	#	#	#	#	#	#	#	#	#	#	63	63	80	80	100	100	-	-	-	
500V	#	#	#	#	#	#	#	#	#	#	50	63	80	80	80	80	-	-	-	
600V	#	#	#	#	#	#	#	25	40	50	50	63	63	63	80	80	-	-	-	
690V	#	#	#	#	#	#	#	25	40	50	50	63	63	63	63	63	-	-	-	
		For ranges GPS2BSA_ / GPS2MSA_																		
230V	-	-	-	-	-	-	-	-	-	-	#	#	#	125	125	125	125	125	160	
400V	-	-	-	-	-	-	-	-	-	-	#	80	100	125	125	125	125	125	160	
440V	-	-	-	-	-	-	-	-	-	-	63	63	80	80	100	100	125	125	125	
500V	-	-	-	-	-	-	-	-	-	-	63	63	80	80	80	80	100	100	125	
600V	-	-	-	-	-	-	-	-	-	-	63	63	63	63	80	80	100	100	100	
690V	-	-	-	-	-	-	-	-	-	-	63	63	63	63	63	63	80	80	100	
		For ranges GPS2BHA_ / GPS2MHA_																		
230V	-	-	-	-	-	-	-	-	-	-	#	#	#	#	#	#	#	#	#	
400V	-	-	-	-	-	-	-	-	-	-	#	#	100	125	125	125	125	125	160	
440V	-	-	-	-	-	-	-	-	-	-	63	63	80	80	100	100	125	125	125	
500V	-	-	-	-	-	-	-	-	-	-	63	63	80	80	80	80	100	100	125	
600V	-	-	-	-	-	-	-	-	-	-	80	63	63	63	80	80	100	100	100	
690V	-	-	-	-	-	-	-	-	-	-	80	63	63	63	63	63	63	80	100	

Back-up gl/gG fuses only if $I_{cs} > I_{cu}$ (kA)

Manual motor starter: GPS1...

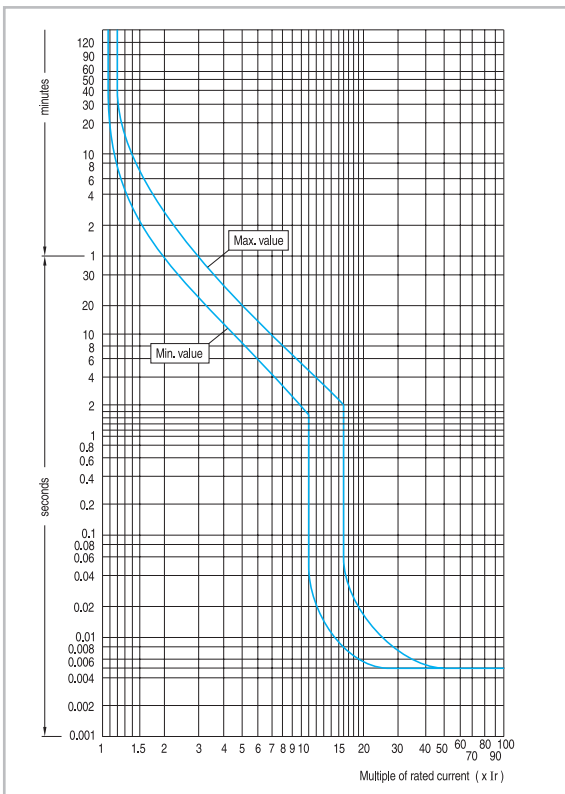

Manual motor starter: GPS2...

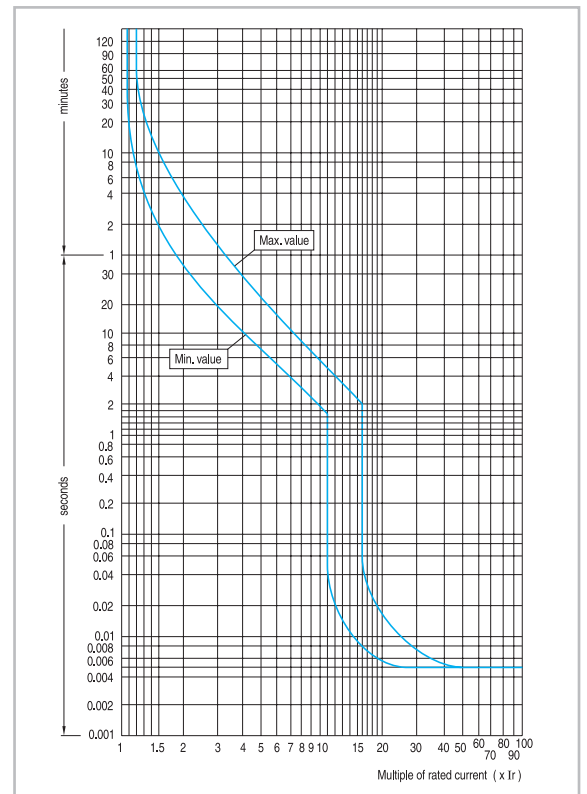

Specific let-through energy at $U_e = 400/415\text{ V}$

Manual motor starter: GPS1...

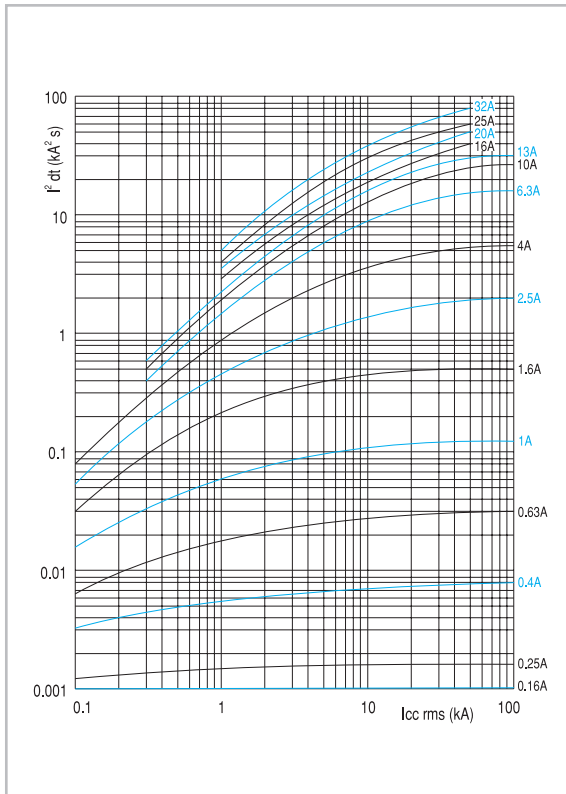

Manual motor starter: GPS2...

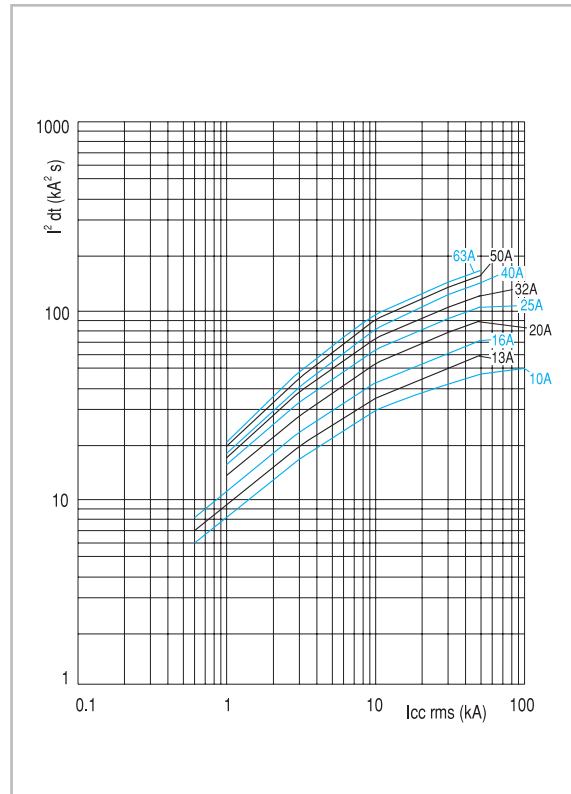

Peak current limitation at $U_e = 400/415\text{ V}$

Manual motor starter: GPS1...

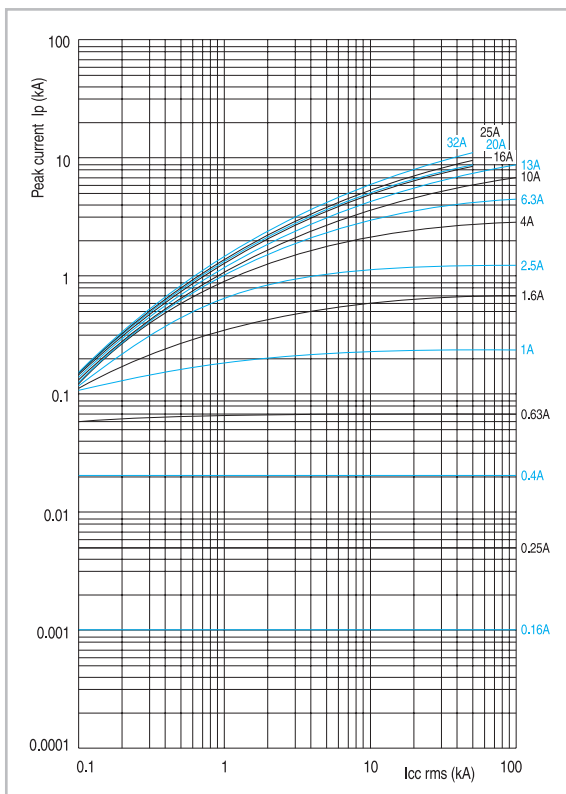

Manual motor starter: GPS2...

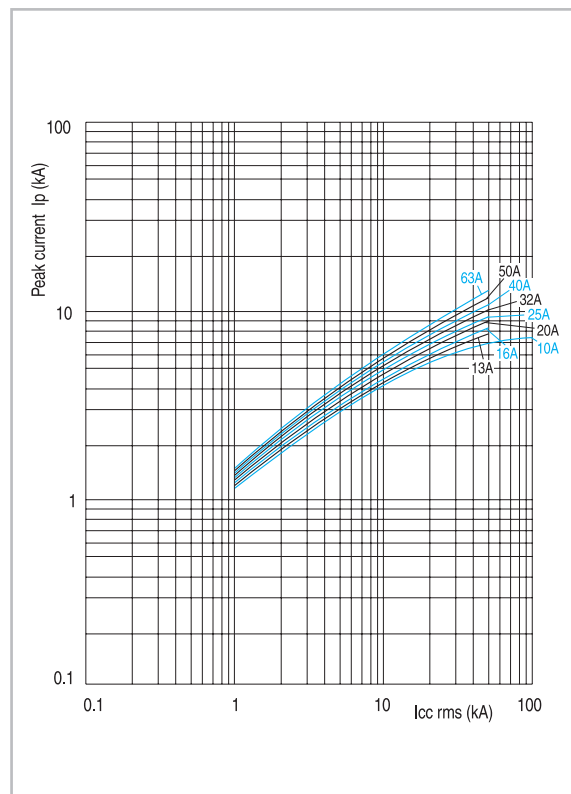

Mounting possibilities of the auxiliaries



Wiring diagram	Type	Description
Frontal auxiliaries		
	Auxiliary contact block	1NO or 1NC
	Alarm contact block	1NO or 1NC
Lateral auxiliaries		
	Auxiliary contact block	2NO 1NO + 1NC 2NC
	Auxiliary contact block	2NO 1NO + 1NC 2NC
	Auxiliary/alarm contact block	1NO (alarm) + 1NO (auxiliary) 1NO (alarm) + 1NC (auxiliary) 1NC (alarm) + 1NO (auxiliary) 1NC (alarm) + 1NC (auxiliary)
	Short-circuit alarm contact block	1NO + 1NC
	Shunt trip	
	Undervoltage trip	
	Undervoltage trip with 2NO early make auxiliary contacts	

Shunt trip, undervoltage trip and undervoltage with 2NO contacts can be mounted together with any frontal block or left lateral block with above mentioned restrictions

Auxiliaries

Catalogue reference	GPAC_F..	GPAC_L..	GPAL..	GPAD..	GPAE..
Aux. frontal block	Aux. lateral block		Alarm frontal block	Alarm/aux. lateral block	Short-circuit alarm block
Cont. cap. contacts class (UL508)	B300 / Q300		B300 / Q300	A600 / P300	A600 / P300
Back-up fuses gG, gI	6A		6A	10A	10A
Utilization category AC-15					
Rated operating voltage Ue (V AC)	48 125 230	48 125 230 400 500 690	48 125 230	48 125 230 400 500 690	48 125 230 400 500 690
Rated operational current (A)	5 3 1.5	6 4 4 2.2 1.5 0.6	5 3 1.5	6 4 4 2.2 1.5 0.6	6 4 4 2.2 1.5 0.6
Utilization category DC-13					
Rated operating voltage Ue (V DC)	48 110 220	48 110 220	48 110 220	48 110 220	48 110 220
Rated operational current (A)	1.38 0.55 0.27	5 1.3 0.5	1.38 0.55 0.27	5 1.3 0.5	5 1.3 0.5
Mounting data					
Mounting side	Front	Left or right	Frontal right	Left	Left
Terminals capacity:	2x0.5...2.5mm ²		2x0.5...2.5mm ²	2x0.5...2.5mm ²	2x0.5...2.5mm ²
Solid or stranded without end sleeve	2x18...14		2x18...14	2x18...14	2x18...14
AWG	screw		screw	screw	screw
Terminal type	0.8Nm		0.8Nm	0.8Nm	0.8Nm
Tightening torque	Pz2/Slotted		Pz2/Slotted	Pz2/Slotted	Pz2/Slotted
Screwdriver	Maintain same width		Maintain same width	Increase width 9mm	Increase width 9mm
Dimensions width (mm)	Increase width 9mm		Increase width 9mm	Increase width 9mm	Increase width 9mm

Catalogue reference	GPAAU	GPAS
Undervoltage trip	Shunt trip	Shunt trip
Power consumption:		
Pick-up (VA/W)	21/12	21/12
Hold (VA/W)	8/1.2	-
Operating voltage		
Tripping (V)	0.35Ve-0.7Ve	0.7Ve-1.1Ve
Pick-up (V)	0.85Ve-1.1Ve	-
Max. operation supply (ms)	-	5(DC)
Rated operating voltage Ue	24V 50Hz 24V 60Hz 48V 50Hz 48V 60Hz 110/127V 50Hz / 120V 60Hz 208V 60Hz 220/230V 50Hz / 240/260V 60Hz 240V 50Hz / 277V 60Hz 240V 50Hz / 277V 60Hz 380/400V 50Hz 415/440V 50Hz / 460/480V 60Hz 500V 50Hz / 600V 60Hz	24V 50/60Hz 48V 60Hz 48V 50Hz / 60V 60Hz 110/127V 50Hz / 120V 60Hz 208V 60Hz 220/230V 50Hz / 240/260V 60Hz 240V 50Hz / 277V 60Hz 380/400V 50Hz 415/440V 50Hz / 460/480V 60Hz 500V 50Hz / 600V 60Hz
Contacts class (UL508)	-	24 to 60V DC 110 to 240V DC
Back-up fuses (gG,gI)	10A	10A
Mounting data		
Mounting side	Right	Right
Terminals capacity:	2x0.5...2.5mm ²	
Solid or stranded without end sleeve	2x18...14	
AWG	Screw	
Terminal type	0.8Nm	
Tightening torque	Pz2/Slotted	
Screwdriver	Increase width 18mm	
Dimensions width (mm)	Increase width 18mm	

Detailed dimensions see page C.19



Dimensional drawings

Manual Motor Starter - GPS1 rocker

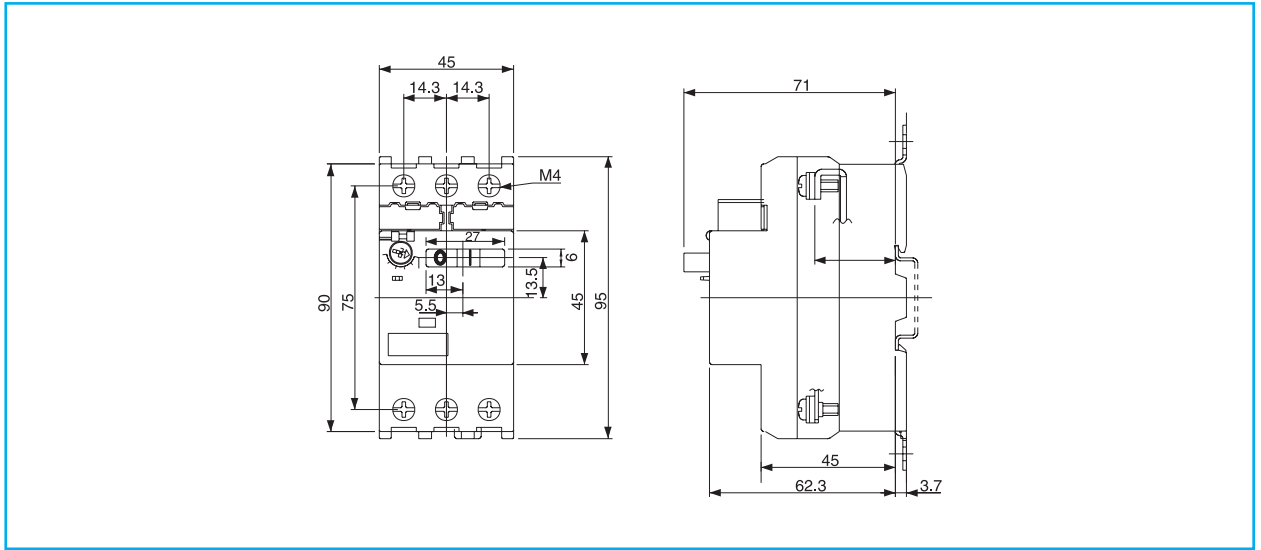

Manual Motor Starter - GPS1 rotary

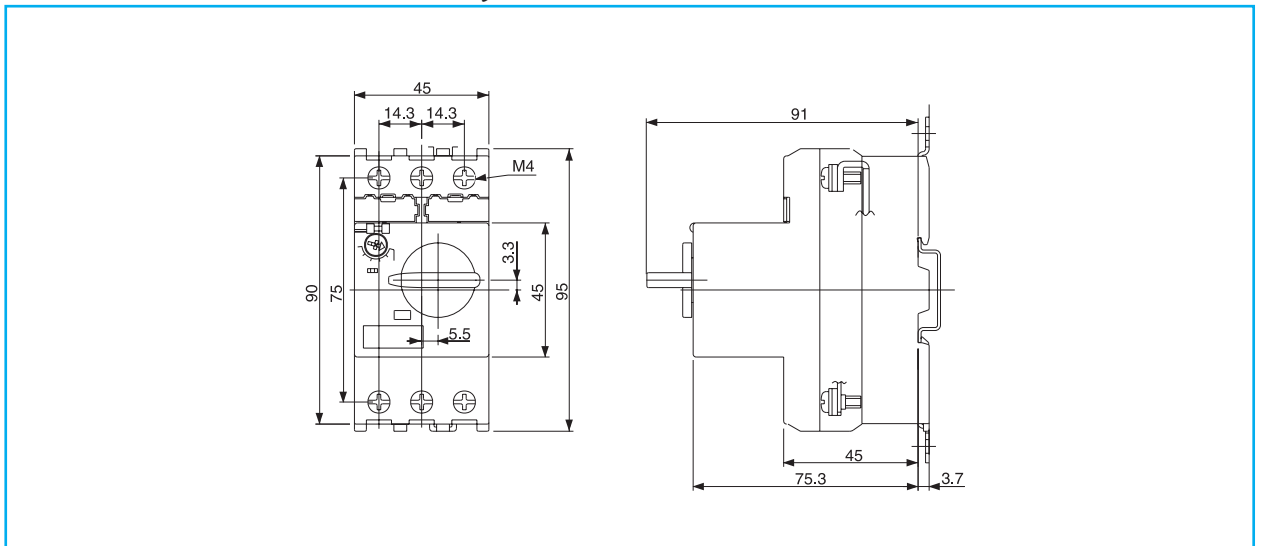

Manual Motor Starter - GPS2

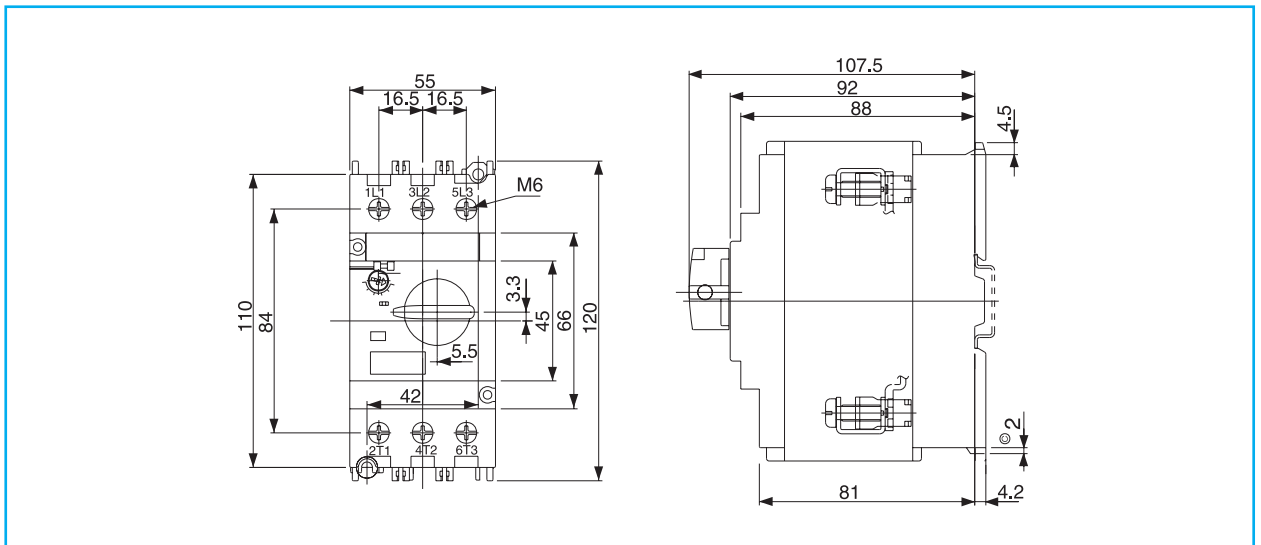

Dimensions in mm (inch = mm x 0.03937) - Weight in kg (lb = kg x 2.2046)

Auxiliary contact blocks

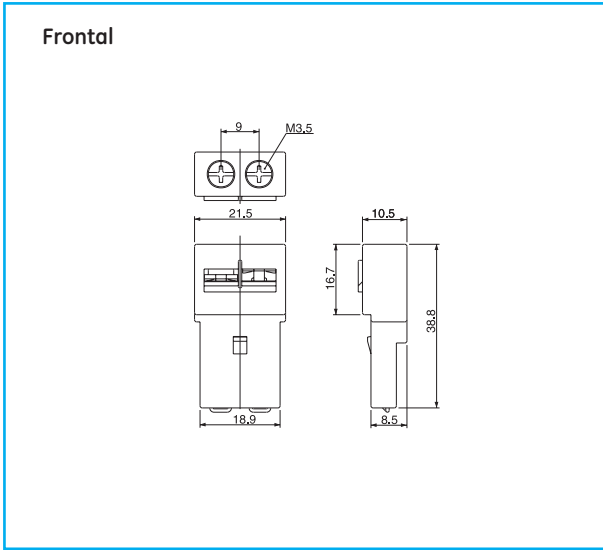

Auxiliary contact blocks

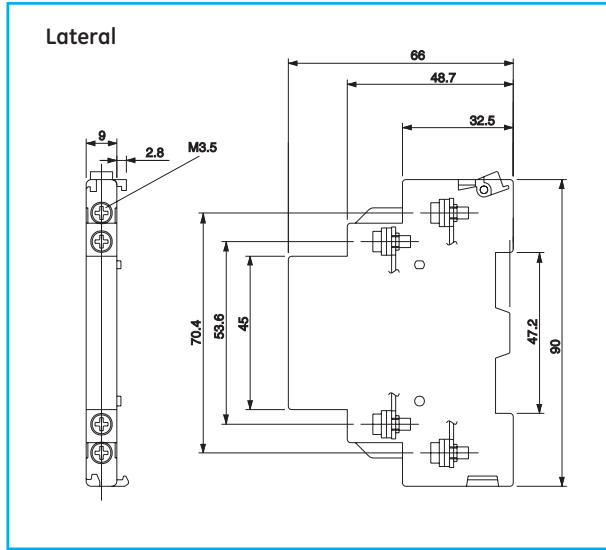

Alarm contact blocks

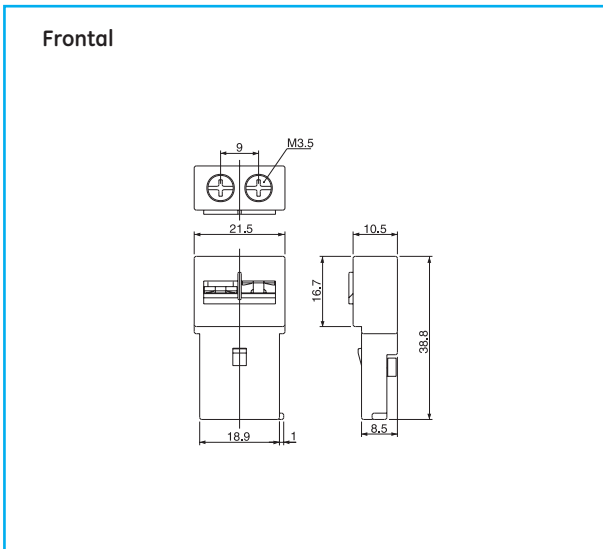

Alarm contact blocks

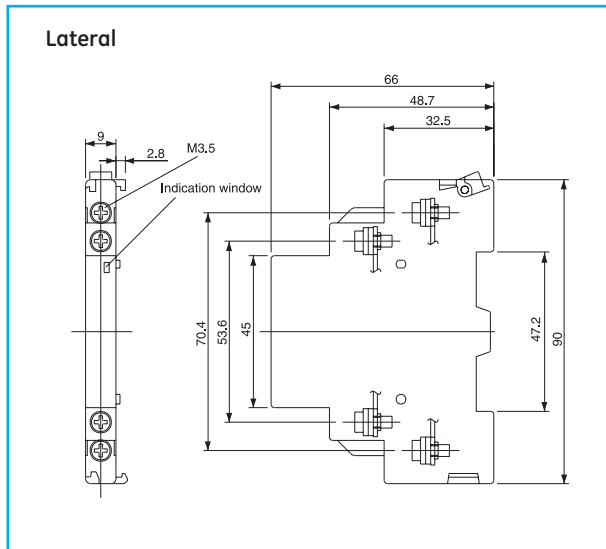

Shunt and undervoltage trip devices

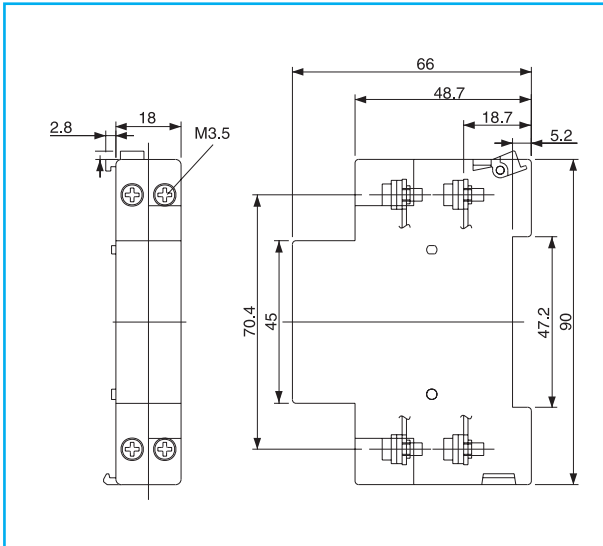

Short-circuit contact block

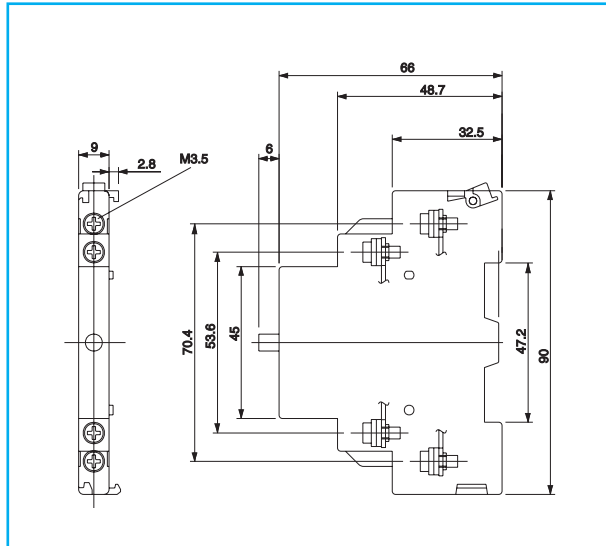

Dimensions in mm (inch = mm x 0.03937) - Weight in kg (lb = kg x 2.2046)



Dimensional drawings

GPS1 rocker + Undervoltage trip device with 2NO contacts

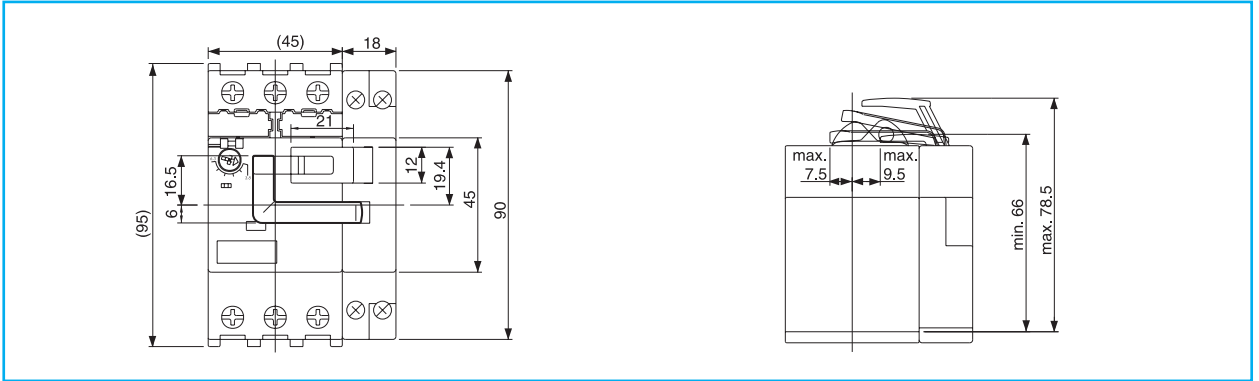

GPS1 rocker + Auxiliaries

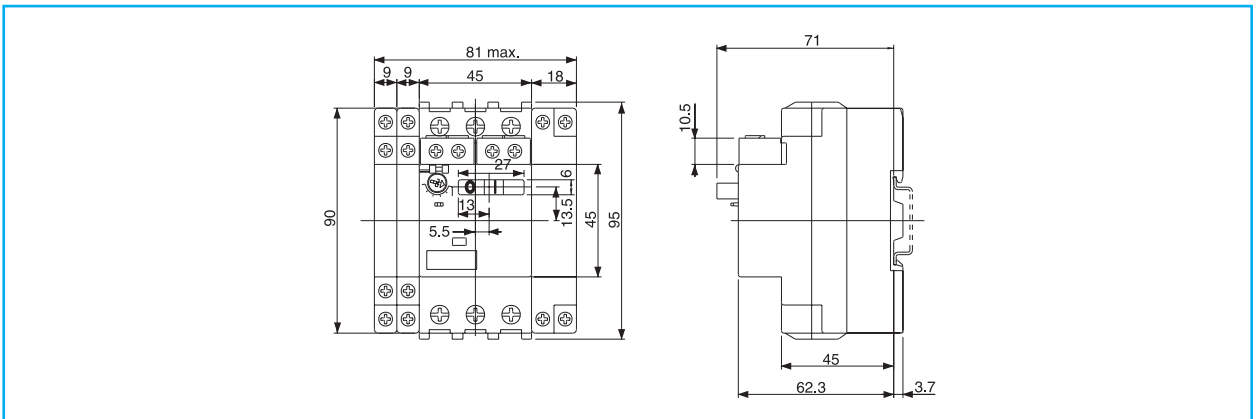

GPS1 rotary + Auxiliaries

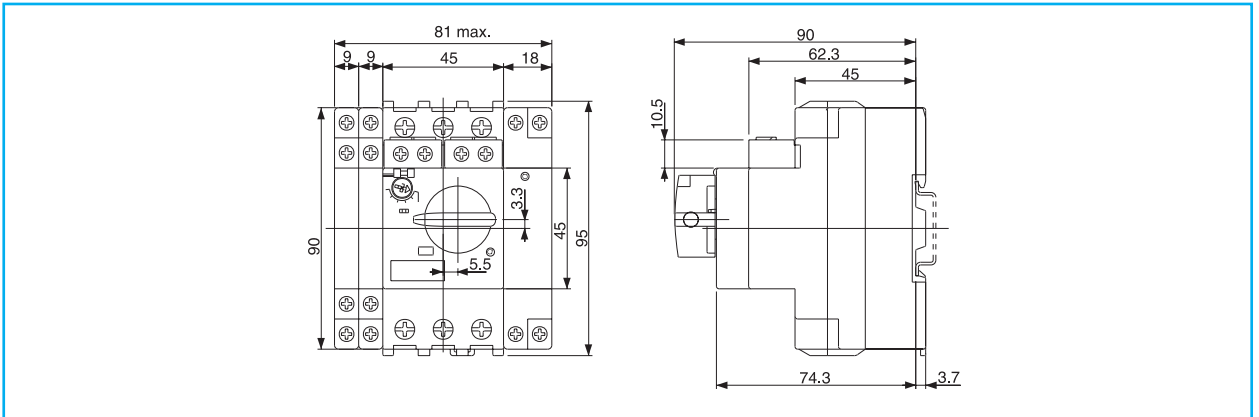

GPS2 + Auxiliaries

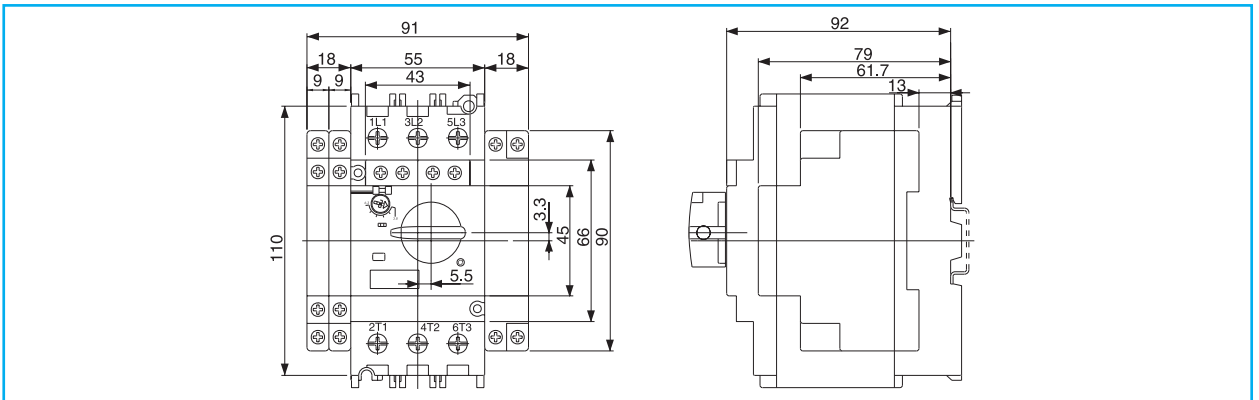

Dimensions in mm (inch = mm x 0.03937) - Weight in kg (lb = kg x 2.2046)

External handle operator

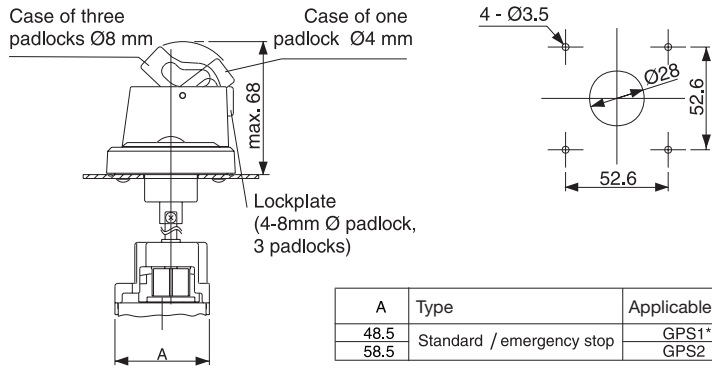
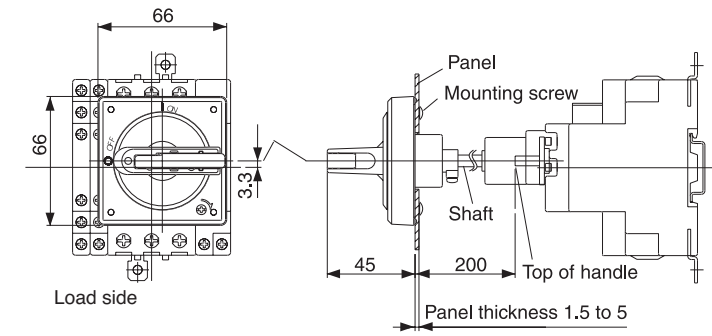

A	Type	Applicable frame
48.5	Standard / emergency stop	GPS1*H
58.5		GPS2

Dimensions in mm (inch = mm x 0.03937) - Weight in kg (lb = kg x 2.2046)



Dimensional drawings

Enclosure for GPS1 - Surface mounting

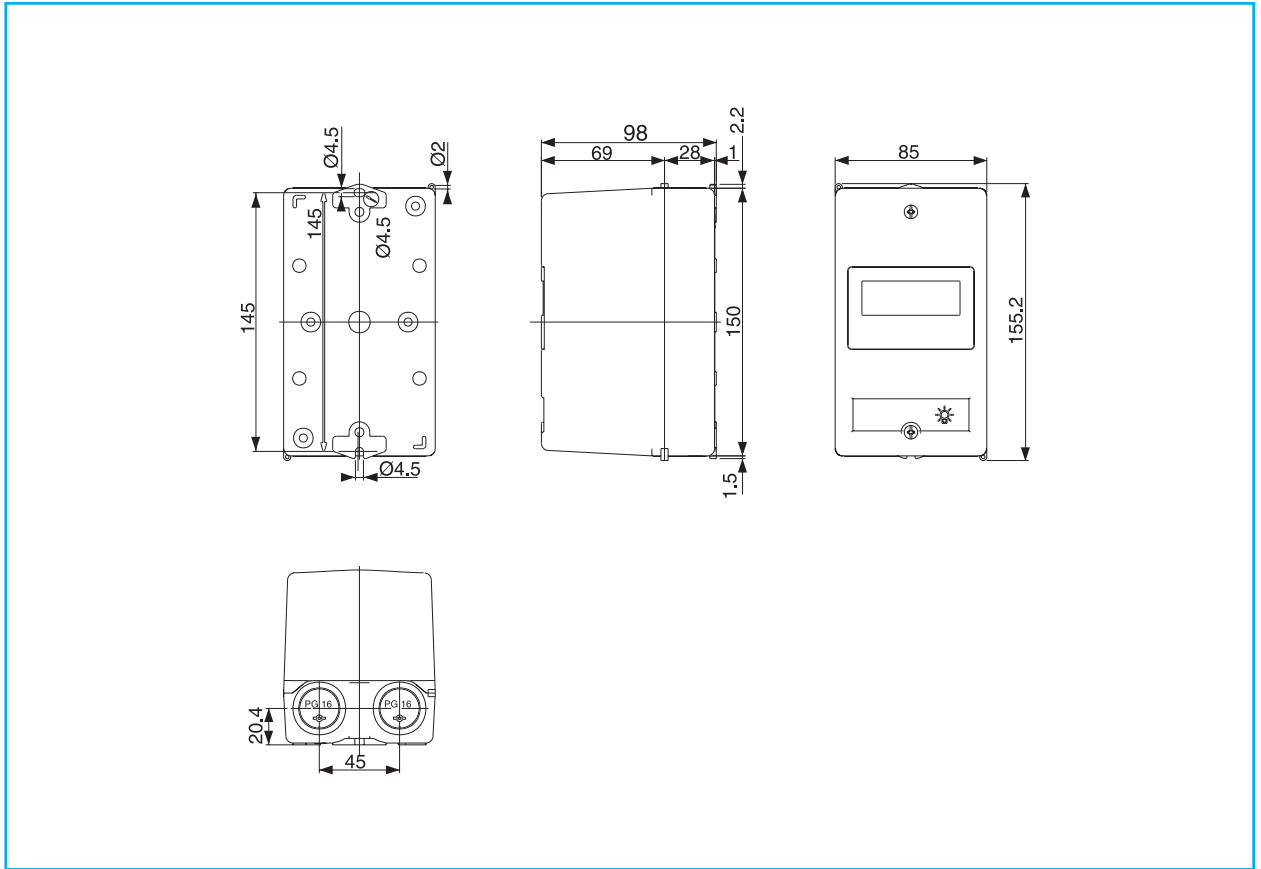

Enclosure for GPS1 - Surface mounting with padlocking device

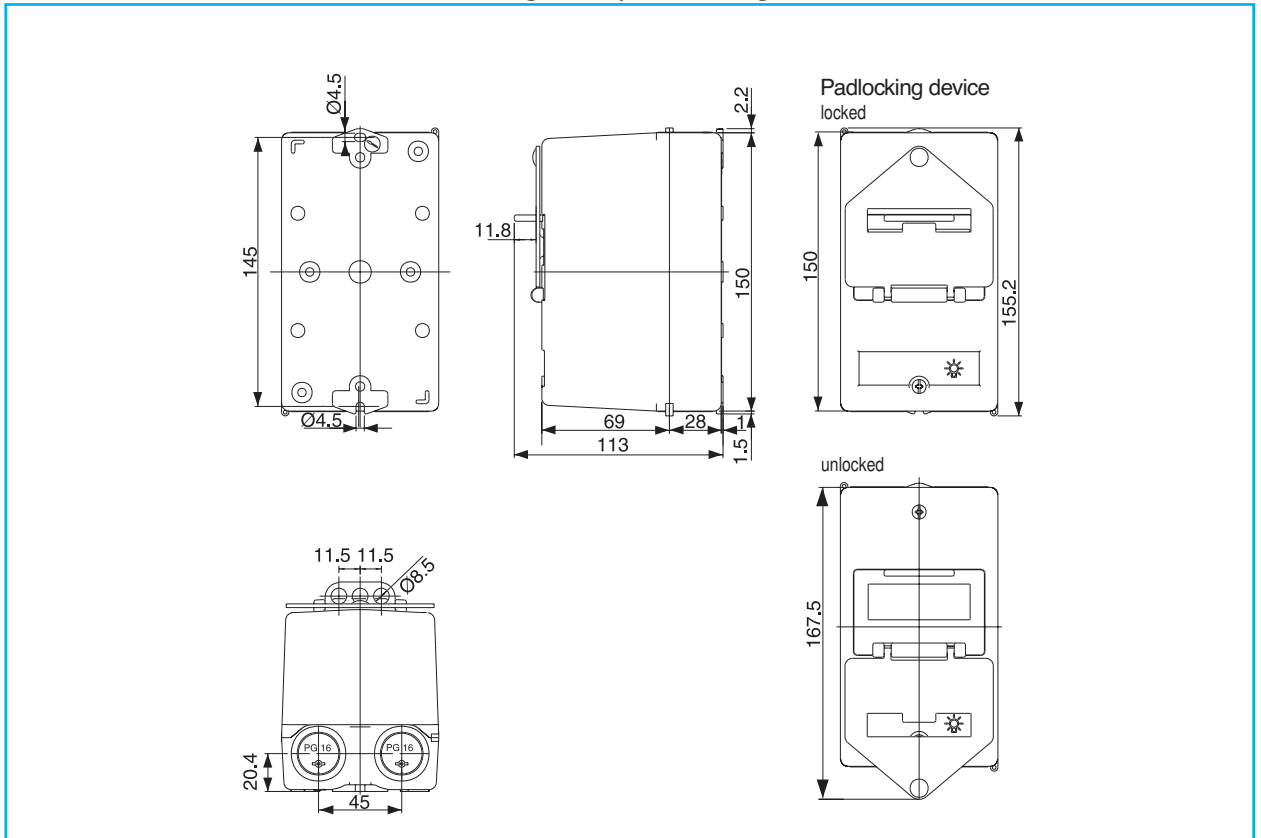

Dimensions in mm (inch = mm x 0.03937) - Weight in kg (lb = kg x 2.2046)

Enclosure for GPS1 - Surface mounting with emergency push-button

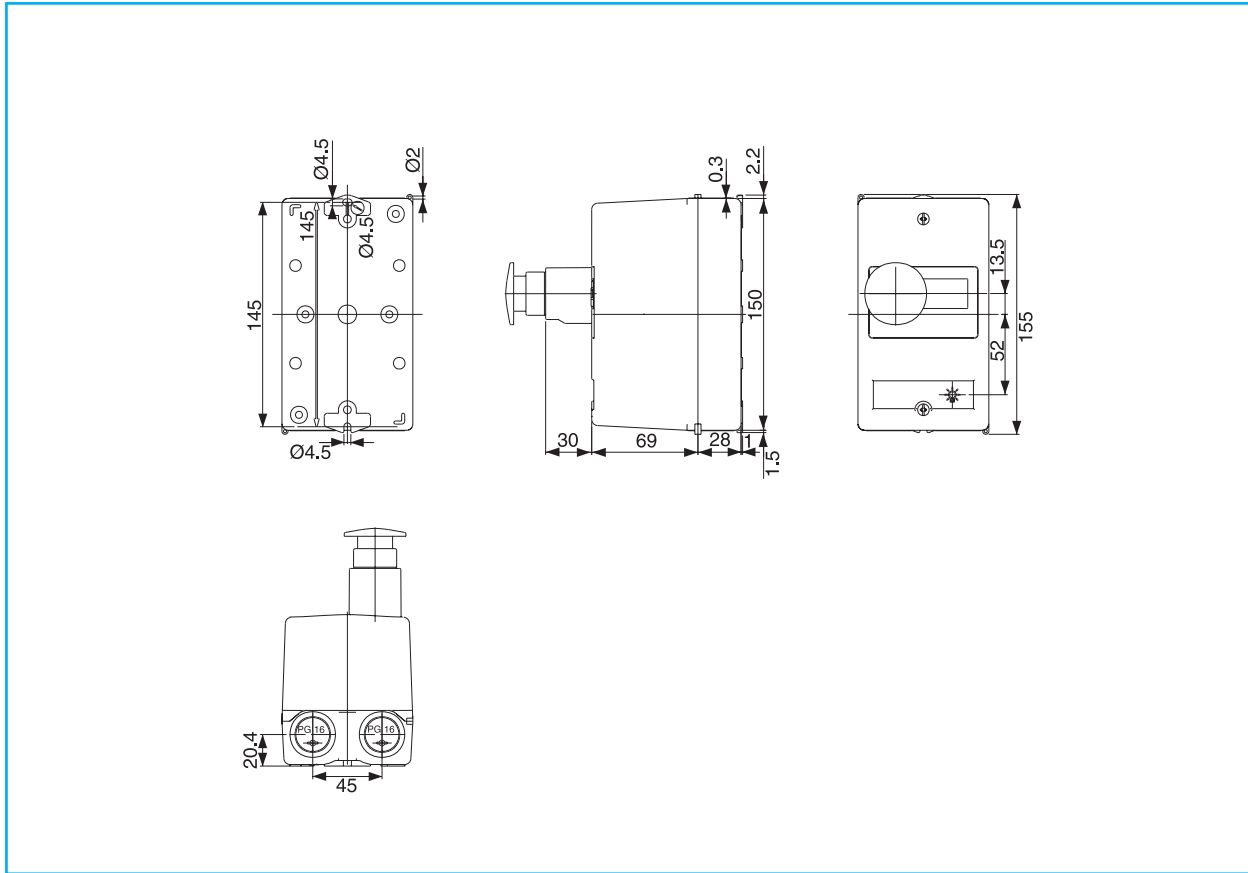

Dimensions

Intro

A

B

C

D

E

F

G

H

I

X

Dimensions in mm (inch = mm x 0.03937) - Weight in kg (lb = kg x 2.2046)



Dimensional drawings

Enclosure for GPS1 - Flush mounting

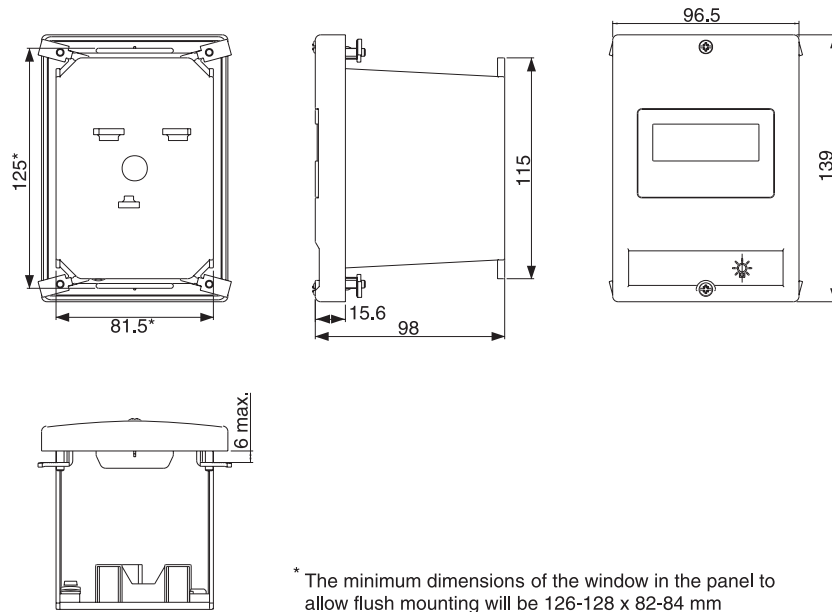

Enclosure for GPS1 - Flush mounting with padlocking device

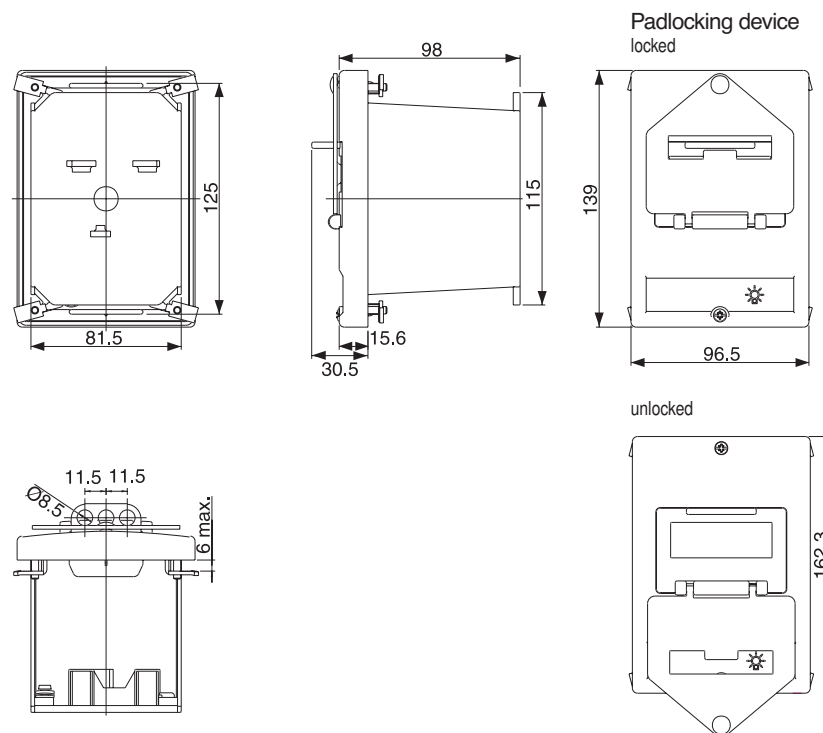

Dimensions in mm (inch = mm x 0.03937) - Weight in kg (lb = kg x 2.2046)

Everything is under control

Motor protection circuit breaker

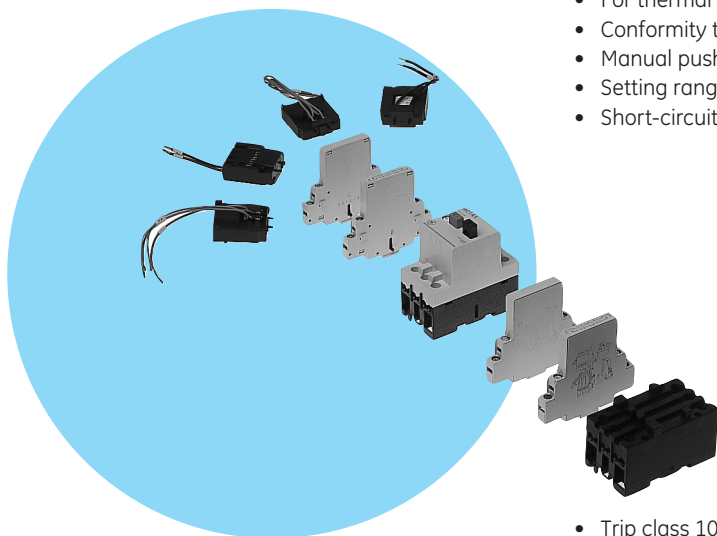

- For thermal and magnetic protection of AC and DC motors
- Conformity to standards IEC 947-2, IEC 947-4-1 and VDE 0660
- Manual push-button operation
- Setting ranges from 0.1 to 25A at 690V AC and 220V DC
- Short-circuit capacity of 65kA up to setting range of 1.6-2.5A/400V

Standards

IEC 947-2
IEC 947-4-1
VDE 0660

Approvals/Marking



- Trip class 10
- Instant magnetic tripping (12 times the maximum operating current Ie)
- Single phase protection
- Ambient temperature compensation between - 5° C and + 40° C
- Internal and external accessories easy to mount
- Quick fixing on DIN rail EN 50022-35 and, with two screws, on plate or wall
- Terminals protected against accidental contacts (IP20)
- Suitable for isolation ($\text{---} \times$) and positive padlocking in open position (IEC 947-1 § 7-1-6)



Motor protection circuit breakers



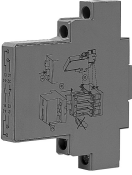

3-phase motor AC3 380/415V kW	Magnetical tripping current A	Thermal tripping current (setting range)		Cat. no.	Ref. no.	Pack.
		Min. A	Max. A			
0.02	1.9	0.1	0.16	SFKOA	120001	1
0.06	3.0	0.16	0.25	SFKOB	120002	1
0.06 / 0.09	4.8	0.25	0.4	SFKOC	120003	1
0.12 / 0.18	7.5	0.4	0.63	SFKOD	120004	1
0.25	12	0.63	1	SFKOE	120005	1
0.37 / 0.55	19	1	1.6	SFKOF	120006	1
0.75	30	1.6	2.5	SFKOG	120007	1
1.1 / 1.5	48	2.5	4	SFKOH	120008	1
2.2	75	4	6.3	SFKOI	120009	1
3.7 / 4.0	120	6.3	10	SFKOJ	120010	1
5.5 / 7.5	190	10	16	SFKOK	120011	1
9.0	240	16	20	SFKOL	120012	1
11 / 12.5	300	20	25	SFKOM	120013	1

Circuit breaker to protect transformers on request

Auxiliary contact blocks

					Cat. no.	Ref. no.	Pack.	
	Side mounting		1NO	1NC	SFAL11N	120020	5	
			2NO		SFAL20N	120021	5	
			1NO	1NC	SFAL11D	120022	5	
			(advanced on closing)					
			2NO		SFAL20D	120023	5	
			(advanced on closing)					
	For lower energy levels (G 4V, G 4mA)	1 change-over PE + N conductor	2NO		SFAL11S	120027	1	
			2NO		SFALPEN	264826	1	
			2NO					
	Internal mounting		1NO	1NC	SFAI11	120024	5	
		Switch trip indicator-alarm	1NO		SFAK10	120025	5	
			1NC		SFAK01	120026	5	

Auxiliary contact blocks

					Cat. no.	Ref. no.	Pack.	
	Minimum power	Functioning range: $0.35U_e < U < 0.7U_e$						
		Manual reset						
		Dissipated power 2.2VA / 1W						
			110V / 50Hz	120V / 60Hz	SFB0RJ	120034	5	
			220V / 50Hz	240V / 60Hz	SFB0RN	120035	5	
	380V / 50Hz	440V / 60Hz	SFB0RU	120036	5			
	Undervoltage release special for machinery	According to IEC204-1, DIN VDE 0113, INRS Art. L233-5						
		A combination of a special undervoltage release and auxiliary contact block SFAL20D						
			110V / 50Hz	120V / 60Hz	SFB0RJM	107256	5	
			220V / 50Hz	240V / 60Hz	SFB0RNM	120114	5	
			380V / 50Hz	440V / 60Hz	SFB0RUM	120115	5	
	Shunt trip	Functioning range: $0.7U_e < U < 1.2U_e$						
		Manual reset						
			110V / 50Hz	120V / 60Hz	SFB0AJ	120030	5	
			220V / 50Hz	240V / 60Hz	SFB0AN	120031	5	
			380V / 50Hz	440V / 60Hz	SFB0AU	120032	5	

Current limiter

					Cat. no.	Ref. no.	Pack.
	Current limiter	Combined with SFK.					
		Upgrades breaking capacity to 50kA/3~400V					
		Not available UL, CSA.					
		$I_n = 32A$			SFVH03	120050	1

Order codes

Intro

A

B

C

D

E

F

G



H

I





X



Enclosures

				Cat. no.	Ref. no.	Pack.
	Surface mounting	Cable entry PG16	IP41-PG16	SFS04	120040	1
			Conversion kit IP55	SFS0K2	120046	1
		Cable entry PG16	IP55-PG16	SFS05	120041	1
		Cable entry Metric	IP41-M25	SFS04M	212558	1
		Cable entry Metric	IP55-M25	SFS05M	212559	1
	Flush mounting		IP41	SFE04	120042	1
			Conversion kit IP55	SFE0K2	120047	1
			IP55	SFE05	120043	1

Accessories for enclosures

				Cat. no.	Ref. no.	Pack.
	Neutral connection	For use with surface and flush mounting enclosures		SFVNO	101369	1
	Padlocking device	Up to 3 padlocks 6 - 8mm		SFVNO	101369	1
	Emergency mushroom push-buttons IP55	Impulse function		SFPS0	120051	1
		Latched, pull to release		SFPRO	120052	1
		Key locked, turn to release		SFPE0	120053	1
		Conversion kit IP55 for SFS04		SFS04K1	245217	1
		Conversion kit IP55 for SFE04		SFE04K1	216604	1
	Indicator lamps for AC and DC	Green 110/120V		GPELGAJ	101375	1
		Green 220/240V		GPELGAN	101376	1
		Green 380/440V		GPELGAU	101377	1
		Green 480/500V		GPELGAX	101378	1
		Green 600V		GPELGAY	101379	1
		Red 110/120V		GPELRAJ	101380	1
		Red 220/240V		GPELRAN	101381	1
		Red 380/440V		GPELRAU	101382	1
		Red 480/500V		GPELRAX	101383	1
		Red 600V		GPELRAY	101384	1
		Transparent 110/120V		GPELCAJ	101385	1
		Transparent 220/240V		GPELCAU	101386	1
		Transparent 380/440V		GPELCAU	101387	1
		Transparent 480/500V		GPELCAX	101388	1
		Transparent 600V		GPELCAV	101389	1

Continued on page C.29

Accessories for enclosures (continued)

				Cat. no.	Ref. no.	Pack.
Three phase busbar block	4 units	Ui 690V / Ie 63A	L = 207mm	GPB104A	101392	2
	5 units	Ui 690V / Ie 63A	L = 261mm	GPB105A	101393	2
	Plastic cover for 3 unused terminals			GPB1GA	101408	2
Supply block	Plastic cover for 3 unused terminals			SFVB8	254537	5

Terminal numbering

Motor protection circuit breaker

SFK...

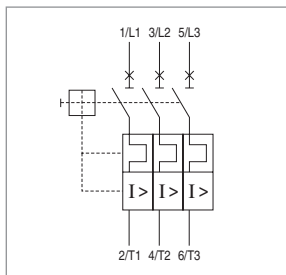

Auxiliary contact blocks

Side mounting

SFAL11N

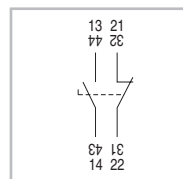

SFAL20N

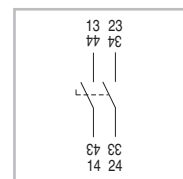

SFAL11D

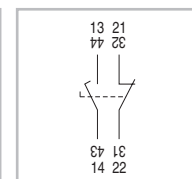

SFAL20D

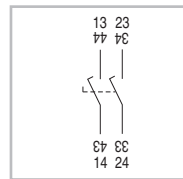

SFAL11S

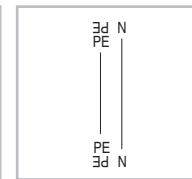
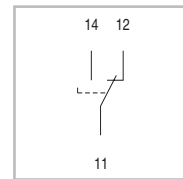

Internal mounting

SFAI11

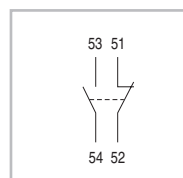

SFAK10

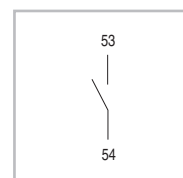

SFAK01

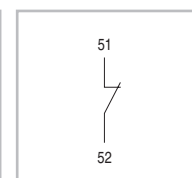

Technical data

General

Rated thermal current (I _{th}) at 40°C	25A
Rated insulation voltage (U _i)	690V
Rated operational voltage (U _e)	AC 690V, 40/60Hz
(see application diagram)	DC 220V, with or without earth

Standards

IEC 947-2	IEC 947-4-1	VDE 0660
-----------	-------------	----------

Approvals

UL	CSA
----	-----

Main circuit

Category	AC3, DC4
Operational frequency limits	40 to 60Hz
Opening time	aprox. 7ms
Mechanical endurance	10 ⁵ operations
Electrical endurance category AC3	10 ⁵ operations
Maximum operating rate	40 operations/hour
Total dissipated power at rated thermal current and hot state	6W

Tripping characteristics

Thermal	
Symmetrical overloads	Class 10 (see curve 1, tripping curves)
Asymmetrical overloads (phase failure)	To IEC 947-4-1 (see curve 2, tripping curves)
Temperature compensation	- 5 to + 40°C

Magnetic	12 x I _e (I _e = max. thermal setting value)
Shunt release	0.7 - 1.2 U _e 100% ED
Operating voltage limits	2.2 VA
Consumption	AC 1W DC 0.85 - 1.1 U _e 100% ED

Undervoltage release	
Operating voltage limits	0.75 - 0.35 U _e
Breaking voltage limits	2.2 VA
Consumption	1W

Wiring capacity	
Rigid wire	min. 2 wires of 0,75mm ² max. 2 wires of 6mm ²
Flexible wire	min. 2 wires of 0,75mm ² max. 2 wires of 4mm ²

Tripping curve

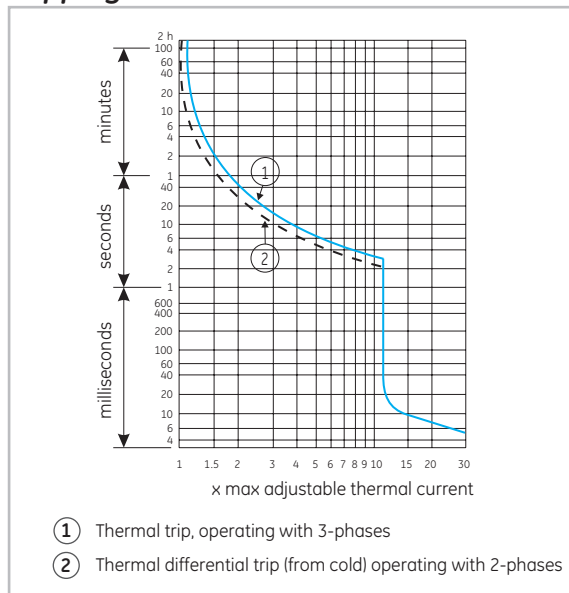

Mounting positions

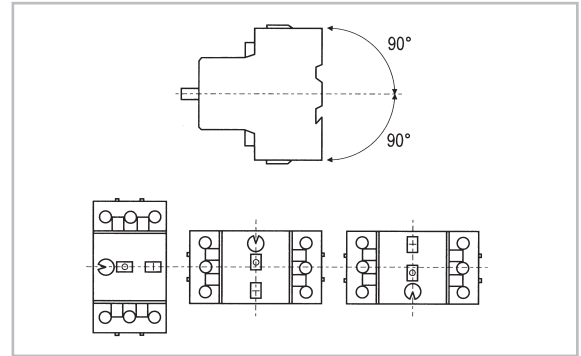

Auxiliary contact blocks

	SFAL	SFAI - SFAK
Rated insulation voltage (U _i) according VDE 0110	500V	500V
Rated thermal current (I _{th})	6A	6A
AC-15	U _e 230V 400V 500V I _e 3,5A 2A 1A	230V 400V 500V 2A 1A 0,5A
DC-13	U _e 60V 110V 220V I _e 1,5A 1A 0,5A	60V 110V 220V 0,7A 0,55A 0,25A
Protective fuse gl	6A	6A
Wiring capacity, Flexible wire	min. 2 x 0,75mm ² max. 2 x 2,5mm ²	2 x 0,75mm ² 2 x 2,5mm ²
Terminal type	M3,5, Pozidriv, safety flange screws	

Wiring diagram

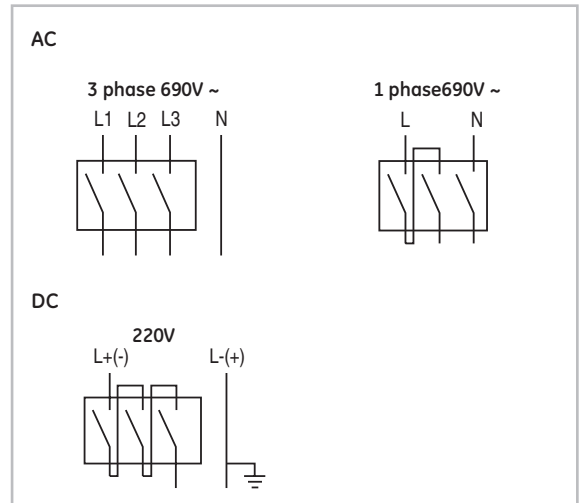

Application diagram for tooling machines

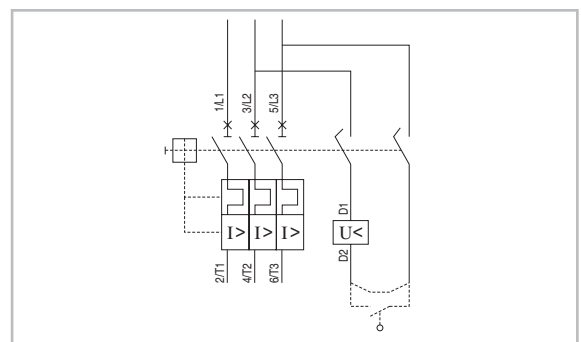

Short-circuit breaking capacity I_{cu}/I_{cs} according to IEC 947-2

Thermal adjustment (A)	230V AC / 220V DC ⁽¹⁾				400V AC				415V AC				500V AC				690V AC			
	3ph motor AC3	I_{cu}	I_{cs}	Fuse ⁽²⁾	3ph motor AC3	I_{cu}	I_{cs}	Fuse ⁽²⁾	3ph motor AC3	I_{cu}	I_{cs}	Fuse ⁽²⁾	3ph motor AC3	I_{cu}	I_{cs}	Fuse ⁽²⁾	3ph motor AC3	I_{cu}	I_{cs}	Fuse ⁽²⁾
	(kW)	(kA)	(kA)	(A)	(kW)	(kA)	(kA)	(A)	(kW)	(kA)	(kA)	(A)	(kW)	(kA)	(kA)	(A)	(kW)	(kA)	(kA)	(A)
0.1 - 0.16	-	65	65	(3)	0.02	65	65	(3)	0.02	65	65	(3)	0.04	65	65	(3)	0.06	42	42	(3)
0.16 - 0.25	-	65	65	(3)	0.06	65	65	(3)	0.06	65	65	(3)	0.06	65	65	(3)	0.12	42	42	(3)
0.25 - 0.4	0.06	65	65	(3)	0.09	65	65	(3)	0.12	65	65	(3)	0.12	65	65	(3)	0.18	42	42	(3)
0.4 - 0.63	0.09	65	65	(3)	0.12	65	65	(3)	0.18	65	65	(3)	0.25	65	65	(3)	0.37	42	42	(3)
0.63 - 1	0.12	65	65	(3)	0.25	65	65	(3)	0.25	65	65	(3)	0.37	65	65	(3)	0.75	1	1	20
1 - 1.6	0.25	65	65	(3)	0.55	65	65	(3)	0.55	65	65	(3)	0.75	65	65	(3)	1.1	1	1	20
1.6 - 2.5	0.37	65	65	(3)	0.75	65	65	(3)	0.75	10	5	25	1.1	3	1.5	25	1.5	1	0.5	20
2.5 - 4	0.75	65	65	(3)	1.5	10 (4)	5 (4)	35	1.5	10	5	35	2.2	3	1.5	35	3	1	0.5	25
4 - 6.3	1.1	65	37.5(4)	(3)	2.2	10 (4)	5 (4)	50	2.2	10	5	50	3	3	1.5	50	4	1	0.5	35
6.3 - 10	2.2	10 (4)	5 (4)	80	4	4 (4)	2 (4)	80	4	4	2	80	5.5	3	1.5	50	7.5	1	0.5	35
10 - 16	4	6 (4)	3 (4)	80	7.5	4 (4)	2 (4)	80	7.5	3.5	1.75	80	9	3	1.5	63	11	1	0.5	35
16 - 20	5	6 (4)	3 (4)	80	9	4 (4)	2 (4)	80	9	2.5	1.25	80	11	1.5	0.75	63	15	1	0.5	50
20 - 25	5.5	6 (4)	3 (4)	80	11	4 (4)	2 (4)	80	12.5	2.5	1.25	80	15	1.5	0.75	63	22	1	0.5	50

I_{cu} = Ultimate short-circuit breaking capacity
 I_{cs} = Service short-circuit breaking capacity

- (1) At 220V, $t = 15$ ms
- (2) Maximum value of the fuses when the presumed short circuit current is higher than the breaking capacity of the device. Type D, slow or NH type gG/gL.
- (3) No back-up fuse required to the I_{cu} value
- (4) 50 kA in combination with current limiter

Dimensional drawings

Motor protection circuit breaker

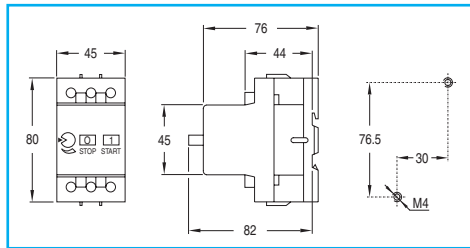

Auxiliary contact block Current limiter

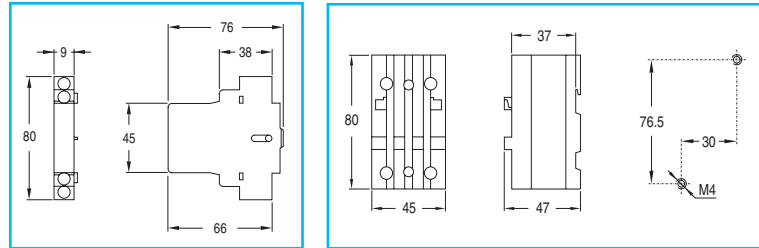

Enclosures: surface mounting

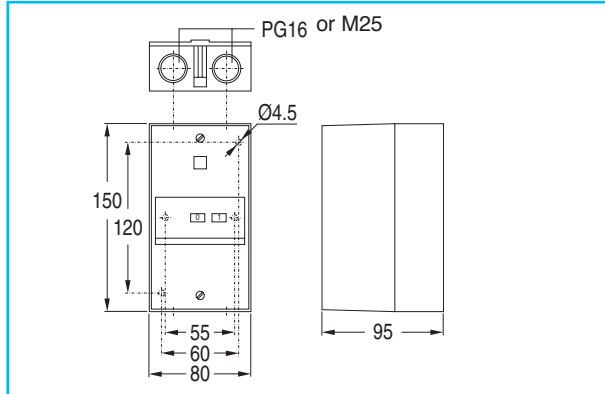

Enclosure to combine with contactor

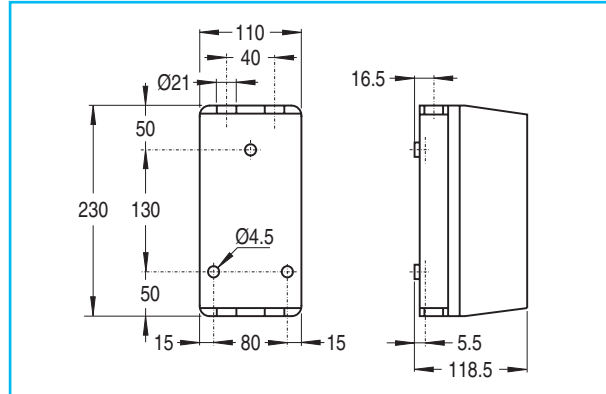

Enclosures: flush mounting

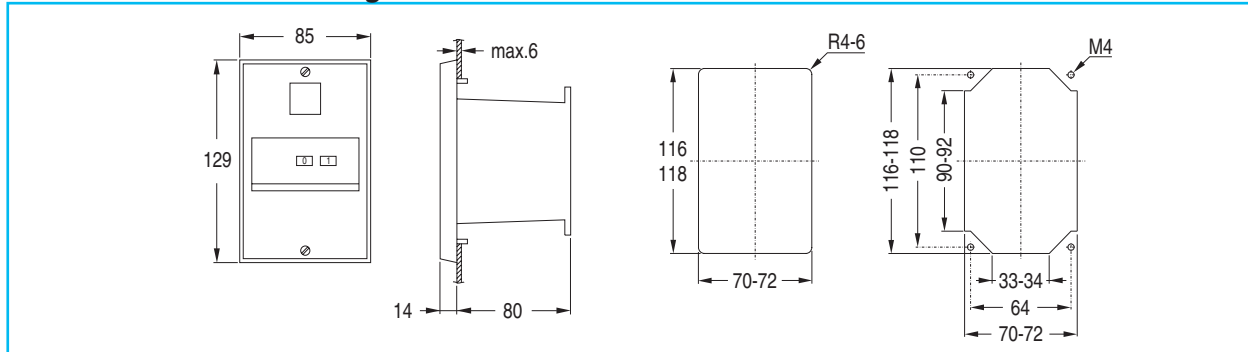

Dimensions in mm (inch = mm x 0.03937) - Weight in kg (lb = kg x 2.2046)

Everything is under control

- D.3 Utilization categories
- D.7 Machine directive - B10d value for contactors

Selection tables

- D.8 Coordination tables
- D.21 IE3 ready
- D.22 Direct-on-line starters
- D.29 Star-delta starters
- D.33 Contactors for transformers
- D.34 Contactors for capacitors switching
- D.40 Contactors for control lighting circuits
- D.42 Contactors for DC utilization

POWER DEVICES

Contactors and overload relays

Auxiliary relays and contactors

Motor protection devices

Applications

UL Applications

- D.45 Horsepower and general-use ratings
- D.47 High-available short circuit ratings
- D.57 Combination motor controllers

AUXILIARY DEVICES

Main switches

Control and signalling units

- D.61 Product index alpha numeric - UL reference

POWER ELECTRONICS

Speed drive units

CLN Contactors

- D.65 Overview
- D.66 Order codes

Soft starters

- D.67 Accessories

ENCLOSURES

Product overview

- D.73 Technical data

Alphabetical index

- D.76 Dimensions

Intro

A

B

C

D

E

F

G

H

I

X



Everything is under control

Utilization categories according to IEC 60947-4-1

Standard utilization categories AC

Category	Typical applications
AC-1	Non-inductive or slightly loads. Resistance furnaces
AC-2	Slip-ring motors: starting, plugging
AC-3	Squirrel-cage motors (1): starting, switching off motors during running.
AC-4	Squirrel-cage motors: starting, plugging, inching.
AC-5 a	Discharge lamps
AC-5 b	Incandescent lamps
AC-6 a	Transformers
AC-6 b	Cos ϕ capacitors
AC-7 a	Slightly inductive loads for domestic applications
AC-7 b	Motors in domestic applications
AC-8 a	Drive motors for cooling compressors (2) with manual reset and thermal overload relay
AC-8 b	Drive motors for cooling compressors (2) with manual reset and automatic reset

Standard utilization categories DC

Category	Typical applications
DC-1	Non-inductive or slightly inductive loads. Resistance furnaces
DC-3	Shunt motors: starting, plugging, inching
DC-5	Series motors: starting, plugging, inching
DC-6	Incandescent lamps

- (1) Category AC-3 can be used for accidental not continuous short period service, while mounting and testing machines. The number of operations shall not be greater than 5 per minute or 10 per 10 minutes.
- (2) The drive motor of a hermetic cooling compressor is an assembly of a motor and compressor in the same housing, without any axle; the motor is working in the cooling liquid.
- (3) Making conditions in alternating current are expressed by effective value. Moreover the asymmetrical current high value, referred to cos ϕ , can assume a higher value.
- (4) Tolerance for cos $\phi = \pm 0.05$
- (5) Tolerance for L/R = $\pm 15\%$

Making and breaking capacity

IEC 60947-4-1

Values given for closing and opening by intermittent use

Cat.	Rated current	Closing (3)			Opening		
		Ic/Ie	Ur/Ue	cos ϕ (4)	Ic/Ie	Ur/Ue	cos ϕ (4)
AC-1	All values	1.5	1.05	0.80	1.5	1.05	0.80
AC-2	All values	4	1.05	0.65	4	1.05	0.65
AC-3	Ie \leq 100A	10	1.05	0.45	8	1.05	0.45
	Ie > 100A	10	1.05	0.35	8	1.05	0.35
AC-4	Ie \leq 100A	12	1.05	0.45	10	1.05	0.45
	Ie > 100A	12	1.05	0.35	10	1.05	0.35

Cat.	Rated current	Closing			Opening		
		Ic/Ie	Ur/Ue	L/R(5) (ms)	Ic/Ie	Ur/Ue	L/R(5) (ms)
DC-1	All values	1.5	1.05	1	1.5	1.05	1
DC-3	All values	4	1.05	2.5	4	1.05	2.5
DC-5	All values	4	1.05	15	4	1.05	15

Electrical endurance

IEC 60947-4-1

Values given for closing and opening intermittent use

Cat.	Rated current	Closing (3)			Opening		
		Ic/Ie	Ur/Ue	cos ϕ (4)	Ic/Ie	Ur/Ue	cos ϕ (4)
AC-1	All values	1	1	0.95	1	1	0.95
AC-2	All values	2.5	1	0.65	2.5	1	0.65
AC-3	Ie \leq 17A	6	1	0.65	1	0.17	0.65
	Ie > 17A	6	1	0.35	1	0.17	0.35
AC-4	Ie \leq 17A	6	1	0.65	6	1	0.65
	Ie > 17A	6	1	0.35	6	1	0.35

Cat.	Rated current	Closing			Opening		
		Ic/Ie	Ur/Ue (ms)	L/R(5)	Ic/Ie	Ur/Ue (ms)	L/R(5)
DC-1	All values	1	1	1	1	1	1
DC-3	All values	2.5	1	2	2.5	1	2
DC-5	All values	2.5	1	7.5	2.5	1	7.5

Ue	Rated voltage
Ie	Rated current
Ur	Recovery voltage
Ic	Breaking current

Utilization category AC-1

Three pole contactors

Type		MC0	MC1	MC2	CL00	CL01	CL02	CL03	CL04	CL05	CL06	CL07	CL08	CL09	CL10
Max. operat. current at ambient temp. of	40°C (A)	20	20	20	25	25	32	45	60	60	90	110	110	140	140
	55°C (A)	20	20	20	25	25	32	45	60	60	90	110	110	140	140
(for all voltages)	70°C (A)	16	16	16	20	20	25	32	48	48	72	88	88	110	110
Max. operat. power	230/220V (kW)	7.5	7.5	7.5	9.5	9.5	12	17	22.5	22.5	30	42	42	53	53
Three-phase resistors	400/380V (kW)	13	13	13	16.5	16.5	22	29	39.5	39.5	55	72.5	72.5	92	92
	440/415V (kW)	15	15	13	18	18	23	32	43	43	57	79	79	100	100
	500V (kW)	17	17	17	21.5	21.5	27.5	39	52	52	69	95	95	121	121
	690/660V (kW)	22.5	22.5	22.5	28.5	28.5	38	51	68.5	68.5	95	125	125	160	160
Cable size	(mm ²)	2.5	2.5	2.5	4	4	6	10	16	16	35	35	35	50	50
Percentage of the max. operational current at	120 ops./h (%)	100	100	100	100	100	100	100	100	100	100	100	100	100	100
	300 ops./h (%)	100	100	100	100	100	100	100	100	100	100	100	100	100	100
	600 ops./h (%)	100	100	100	100	100	100	100	100	100	100	100	100	100	100
	1200 ops./h (%)	100	100	100	100	100	100	100	100	100	100	100	100	80	80
	3000 ops./h (%)	50	50	50	50	50	50	50	50	50	50	50	50	40	40

Type		CK75C	CK08C	CK85B	CK09B	CK95B	CK10C	CK11C	CK12B	CK13B					
Max. operat. current at ambient temp. of	40°C (A)	250	250	315	315	450	600	700	1000	1250					
	55°C (A)	200	200	252	252	382	510	546	736	1125					
(for all voltages)	70°C (A)	155	155	195	195	300	402	468	680	1060					
Max. operat. power	230/220V (kW)	90	90	114	114	170	191	234	289	450					
Three-phase resistors	400/380V (kW)	155	155	196	196	310	329	406	500	780					
	440/415V (kW)	180	180	227	227	343	329	470	578	904					
	500V (kW)	200	200	259	259	389	415	533	657	1027					
	690/660V (kW)	270	270	341	341	537	572	705	867	1354					
	1000V (kW)	400	400	517	517	780	866	1060	1314	2054					
Cable size	(mm ²)	120	120	185	185	2x (30x5)	2x (30x8)	2x (30x8)	2x (30x10)	2x (30x10)					
Percentage of the max. operational current at	120 ops./h (%)	100	100	100	100	100	100	100	100	100					
	300 ops./h (%)	100	100	100	100	100	100	100	100	90					
	600 ops./h (%)	100	100	100	100	100	80	80	80	70					
	1200 ops./h (%)	80	80	80	80	80	-	-	-	-					
	3000 ops./h (%)	40	40	40	40	-	-	-	-	-					

Four pole contactors

Type		MC0	MC1	MC2	CL01	CL02	CL03	CL04	CL05	CL07	CL08(1)	CL09(2)
Max. operat. current at ambient temp. of	40°C (A)	20	20	20	25	32	45	60	90	110	110	140
	55°C (A)	20	20	20	25	32	45	60	90	110	110	140
(for all voltages)	70°C (A)	16	16	16	20	25	32	48	72	88	88	110
Max. operat. power	230/220V (kW)	7.5	7.5	7.5	9.5	12	17	22.5	30	42	42	53
Three-phase resistors	400/380V (kW)	13	13	13	16.5	22	29	39.5	55	72.5	72.5	92
	440/415V (kW)	15	15	15	18	23	32	43	57	79	79	100
	500V (kW)	17	17	17	21.5	27.5	39	52	69	95	95	121
	690/660V (kW)	22.5	22.5	22.5	28.5	38	51	68.5	95	125	125	160
Cable size	(mm ²)	2.5	2.5	2.5	4	6	10	16	35	35	35	50
Percentage of the max. operational current at	120 ops./h (%)	100	100	100	100	100	100	100	100	100	100	100
	300 ops./h (%)	100	100	100	100	100	100	100	100	100	100	100
	600 ops./h (%)	100	100	100	100	100	100	100	100	100	100	100
	1200 ops./h (%)	100	100	100	100	100	100	100	100	100	100	80
	3000 ops./h (%)	50	50	50	50	50	50	50	50	50	50	40

Type		CK07B	CK08B	CK09B	CK95B	CK10C	CK11C	CK12B	CK13B			
Max. operat. current at ambient temp. of	40°C (A)	200	325	400	500	600	700	1000	1250			
	55°C (A)	170	260	320	425	510	546	736	1125			
(for all voltages)	70°C (A)	140	201	272	335	402	468	680	1060			
Max. operat. power	230/220V (kW)	76	123	152	191	228	266	381	476			
Three-phase resistors	400/380V (kW)	131	214	263	329	395	460	658	822			
	440/415V (kW)	143	233	287	359	431	503	719	898			
	500V (kW)	173	281	346	415	519	606	866	1082			
	690/660V (kW)	228	371	457	572	686	800	1143	1428			
	1000V (kW)	-	562	692	866	1039	1212	1732	2165			
Cable size	(mm ²)	95	185	2x (25x5)	2x (30x5)	2x (30x8)	2x (30x8)	2x (30x10)	2x (40x10)			
Percentage of the max. operational current at	120 ops./h (%)	100	100	100	100	100	100	100	100			
	300 ops./h (%)	100	100	100	100	100	100	100	90			
	600 ops./h (%)	100	100	100	100	80	80	80	70			
	1200 ops./h (%)	80	80	80	80	-	-	-	-			
	3000 ops./h (%)	40	40	40	40	-	-	-	-			

Increase in maximum operational current through connection poles in parallel: - 2 poles in parallel: Ie x 1.8
 - 3 poles in parallel: Ie x 2.4
 - 4 poles in parallel: Ie x 3.2

(1) Only types (2NO + 2NC)
 (2) Only types (4NO)



Utilization category AC-3

Three pole contactors

Types			MC0	MC1	MC2	CL00	CL01	CL02	CL03	CL04	CL05	CL07	CL08	CL09	CL10
Operational current I_e for U_e ≤ 400V	(A)		6	9	12	9	12	18	25	32	50	65	80	95	105
Max. operat. power 230/220V	(kW)		1.5	3	3	2.2	3	4	7.5	9	15	18.5	22	25	30
	(HP)		2	4	4	3	4	5.5	10	12	20	25	30	34	40
Three-phase motors 50/60Hz	400/380V (kW)		2.2	4	5.5	4	5.5	7.5	12	16	22	30	37	45	55
	(HP)		3	5.5	7.3	5.5	7.5	10	16	22	30	40	50	60	75
440/415V	(kW)		2.2	4	5.5	4	5.5	7.5	12	16	25	37	45	50	55
	(HP)		3	5.5	7.3	5.5	7.5	10	16	22	34	50	60	68	75
500V	(kW)		3	4	5.5	5.5	7.5	10	15	18.5	30	40	45	55	65
	(HP)		4	5.5	7.3	7.5	10	13.5	20	25	40	55	60	75	88
690/660V	(kW)		3	4	5.5	5.5	7.5	10	15	18.5	35	45	45	55	65
	(HP)		4	5.5	7.3	7.5	10	13.5	20	25	48	60	60	75	88
Percentage of the max. operational current at	120 ops./h (%)		100	100	100	100	100	100	100	100	100	100	100	100	100
	300 ops./h (%)		100	100	100	100	100	100	100	100	100	100	100	100	100
	600 ops./h (%)		100	100	100	100	100	100	100	100	100	100	100	100	100
	1200 ops./h (%)		100	100	100	100	100	100	100	100	100	100	100	100	75
	3000 ops./h (%)		35	35	35	35	35	35	35	35	35	35	35	35	25

Type			CK75C	CK08C	CK09B	CK95B	CK10C	CK11C	CK12B	CK13B
Operational current I_e for U_e ≤ 400V	(A)		150	195	250	309	420	550	700	825
Max. operat. power 230/220V	(kW)		45	65	75	90	125	160	220	250
	(HP)		60	88	100	125	170	220	300	340
Three-phase motors 50/60Hz	400/380V (kW)		75	110	132	160	220	280	375	450
	(HP)		100	150	180	220	300	380	510	610
440/415V	(kW)		80	125	132	185	230	315	400	450
	(HP)		108	170	180	250	312	425	540	610
500V	(kW)		100	132	160	200	300	400	480	500
	(HP)		135	180	220	270	405	540	650	680
690/660V	(kW)		100	155	200	250	375	450	500	550
	(HP)		135	205	270	335	510	610	680	750
1000V	(kW)		65	110	150	200	300	375	450	500
	(HP)		88	150	205	270	405	510	610	680
Percentage of the max. operational current	120 ops./h (%)		100	100	100	100	100	100	100	100
	300 ops./h (%)		100	100	100	100	100	100	80	80
	600 ops./h (%)		100	100	100	100	75	75	75	65
	1200 ops./h (%)		75	75	75	75	-	-	-	-
	3000 ops./h (%)		25	25	25	-	-	-	-	-

Utilization category AC-4

Three pole contactors

Type			MC0	MC1	MC2	CL00	CL01	CL02	CL03	CL04	CL05	CL07	CL08	CL09	CL10
Operational current U_e ≤ 400V	(A)		2.75	3.5	3.5	5	7	8	12	16	18.5	30	37	44	50
Operational power 230/220V (200.000 operations)	(kW)		0.55	0.75	0.75	1.1	1.5	1.8	3	3.7	4	7.5	10	11	13
	(HP)		0.73	1	1	1.5	2	2.4	4	5	5.3	9.7	13	14.6	17.3
400/380V	(kW)		1.1	1.5	1.5	2.2	3	3.7	5.5	7.5	9	15	18.5	22	25
	(HP)		1.5	2	2	3	4	5	7.3	9.7	12	20	24.6	29.2	33
500V	(kW)		1.5	2.2	2.2	3	4	5.5	7.5	10	11	18.5	22	25	30
	(HP)		2	3	3	4	5.3	7.3	9.7	13	14.6	24.6	29.2	33	40
690/660V	(kW)		2.2	3	3	4	5.5	7.5	10	11	15	22	25	30	37
	(HP)		3	4	4	5.3	7.3	9.7	13	14.6	20	29.2	33	40	49
Max. operational current ≤ 400V (35.000 operations)	(A)		6	9	9	9	12	18	25	32	40	65	80	95	105
Max. operational power 400/380V	(kW)		2.2	4	4	4	5.5	7.5	12	16	18.5	30	37	45	55

Type			CK75C	CK08C	CK85B	CK09B	CK95B	CK10C	CK11C	CK12B	CK13B
Operational current U_e ≤ 400V	(A)		65	75	90	110	125	150	165	250	350
Operational power 230/220V	(kW)		18.5	22	25	33	37	45	50	80	110
	(HP)		24.6	29.2	33	44	49	60	66.5	106	146
Three-phase motors 50/60Hz (200.000 operations)	400/380V (kW)		33	40	45	55	63	80	90	132	165
	(HP)		44	53	60	73	83.8	106	119	175	219
500V	(kW)		45	50	63	75	90	100	110	225	250
	(HP)		60	66.5	83.8	100	119	133	146	300	332
690/660V	(kW)		55	63	80	100	110	132	150	250	315
	(HP)		73	83.8	106	133	146	175	200	332	419
Max. operational current ≤ 400V (35.000 operations)	(A)		150	185	205	250	309	420	550	700	825
Max. operational power 400/380V	(kW)		75	90	110	132	160	220	280	375	450



Utilization category AC-1

Three pole contactors

Type			EC09	EC12	EC18	EC25	EC32	EC40	EF50	EF65	EF80	EF95	EF105
Max. operat. current at ambient temp. of	40°C	(A)	25	25	32	45	60	60	90	110	110	140	140
	55°C	(A)	25	25	32	45	60	60	90	110	110	140	140
(for all voltages)	70°C	(A)	20	20	25	32	48	48	72	88	88	110	110
Max. operat. power	230/220V	(kW)	9.5	9.5	12	17	22.5	22.5	30	42	42	53	53
Three-phase resistors	400/380V	(kW)	16.5	16.5	22	29	39.5	39.5	55	72.5	72.5	92	92
	440/415V	(kW)	18	18	23	32	43	43	57	79	79	100	100
	500V	(kW)	21.5	21.5	27.5	39	52	52	69	95	95	121	121
	690/660V	(kW)	28.5	28.5	38	51	68.5	68.5	95	125	125	160	160
Cable size		(mm ²)	6	6	6	10	16	16	35	35	35	50	50
Percentage of the max. operational current at	120 ops./h	(%)	100	100	100	100	100	100	100	100	100	100	100
	300 ops./h	(%)	100	100	100	100	100	100	100	100	100	100	100
	600 ops./h	(%)	100	100	100	100	100	100	100	100	100	100	100
	1200 ops./h	(%)	100	100	100	100	100	100	100	100	100	80	80
	3000 ops./h	(%)	50	50	50	50	50	50	50	50	50	40	40

Utilization category AC-3

Three pole contactors

Types			EC09	EC12	EC18	EC25	EC32	EC40	EF50	EF65	EF80	EF95	EF105
Operational current I_e for U_e ≤ 400V		(A)	9	12	18	25	32	40	50	65	80	95	105
Max. operat. power	230/220V	(kW)	2.2	3	4	7.5	9	11	15	18.5	22	25	30
Three-phase motors 50/60Hz	400/380V	(kW)	4	5.5	7.5	12	16	18.5	22	30	37	45	55
	440/415V	(kW)	5.5	7.5	10	16	22	25	30	40	50	60	75
	500V	(kW)	4	5.5	7.5	12	16	22	25	37	45	50	55
	500V	(HP)	5.5	7.5	10	16	22	30	34	50	60	68	75
	500V	(kW)	5.5	7.5	10	15	18.5	25	30	40	45	55	65
	500V	(HP)	7.5	10	13.5	20	25	34	40	55	60	75	88
	690/660V	(kW)	5.5	7.5	10	15	18.5	30	35	45	45	55	65
	690/660V	(HP)	7.5	10	13.5	20	25	40	48	60	60	75	88
Percentage of the max. operational current at	120 ops./h	(%)	100	100	100	100	100	100	100	100	100	100	100
	300 ops./h	(%)	100	100	100	100	100	100	100	100	100	100	100
	600 ops./h	(%)	100	100	100	100	100	100	100	100	100	100	100
	1200 ops./h	(%)	100	100	100	100	100	100	100	100	100	75	75
	3000 ops./h	(%)	35	35	35	35	35	35	35	35	35	25	25

Utilization category AC-4

Three pole contactors

Type			EC09	EC12	EC18	EC25	EC32	EC40	EF50	EF65	EF80	EF95	EF105
Operational current U_e ≤ 690V		(A)	5	7	8	12	16	18.5	23	30	37	44	50
Operational power	230/220V	(kW)	1.1	1.5	1.8	3	3.7	4	5.5	7.5	10	11	13
(200.000 operations)		(HP)	1.5	2	2.4	4	5	5.3	7.3	9.7	13	14.6	17.3
	400/380V	(kW)	2.2	3	3.7	5.5	7.5	9	11	15	18.5	22	25
		(HP)	3	4	5	7.3	9.7	12	14.6	20	24.6	29.2	33
	500V	(kW)	3	4	5.5	7.5	10	11	15	18.5	22	25	30
		(HP)	4	5.3	7.3	9.7	13	14.6	20	24.6	29.2	33	40
	690/660V	(kW)	4	5.5	7.5	10	11	15	18.5	22	25	30	37
		(HP)	5.3	7.3	9.7	13	14.6	20	24.6	29.2	33	40	49
Max. operational current ≤ 400V		(A)	9	12	18	25	32	40	50	65	80	95	105
(35.000 operations)													
Max. operational power	400/380V	(kW)	4	5.5	7.5	12	16	18.5	22	30	37	45	55



B10d value for contactors

According to ISO 13849-1

This part of ISO 13849 provides safety requirements and guidance on the principles for the design and integration of safety-related parts of control systems (SRP/CS), including the design of software. For these parts of SRP/CS, it specifies characteristics that include the performance level required for carrying out safety functions. It applies to SRP/CS, regardless of the type of technology and energy used (electrical, hydraulic, pneumatic, mechanical, etc.), for all kinds of machinery.

Terms and definitions

Fault: State of an item characterized by the inability to perform a required function, excluding the inability during preventive maintenance or other planned actions, or due to lack of external resources.

Failure: Termination of the ability of an item to perform a required function.

Dangerous failure: Failure which has the potential to put the SRP/CS in a hazardous or fail-to-function state

B10d: Number of cycles until 10 % of the components fails dangerously (for pneumatic and electromechanical components).

Confidence level: Statistical measure of the number of times out of 100 that test results can be expected to be within a specified range.

Calculations

Standard B10 values at a high demand rate. With the help of the B10 value and a simplified formula (see section 6.7.8.2.1 of EN 62061), the user can then calculate the total failure rate of an electromechanical component:

$$\lambda = 0.1 \times C / B10$$

With C = operating cycles per hour. C is specified by the user. The failure rate is made up of safe (λS) and dangerous (λD) failures:

$$\lambda = \lambda S + \lambda D \text{ or:}$$

$$\lambda D = (\text{share of dangerous failures in } \%) \times \lambda$$

The failure rate of the dangerous failures λD of the components used is needed for further calculations.

$$\lambda D = 50\% \text{ (value recommended by ISO 13849-1)}$$

$$\lambda S = (\text{share of safe failures in } \%) \times \lambda$$

The failure rate of the safe failures λS of the components used is needed for further calculations.

$$\lambda S = 10\%$$

CL = Confidence Level used for statistical calculations

Confidence Level used is needed for further calculations

$$CL = 60\%$$

Listed in the following table are the standard B10 and B10d values and the share of dangerous failures for products groups, where B10d is determinate as:

$$B10_d = B10$$

Share of dangerous failures

Test

Electrical endurance (AC3) test has been conducted to collect data which have been taken to calculate B10d value for MC, Efficor (EC) and CL contactors series.

For contactors dangerous failures rate has been calculated according to IEC 60947-5-1. ($\lambda D = 73\%$).

Results

	Contactor type	AC3 Current (A)	B10d (x10 ⁶)
MC1	MC Series	9	1.4
EC09	Efficor	9	2.0
EC12	Efficor	12	2.0
EC18	Efficor	18	1.7
EC25	Efficor	25	1.7
EC32	Efficor	32	1.37
EC40	Efficor	40	1.37
EF50	Efficor	50	1.5
EF65	Efficor	65	1.5
EF80	Efficor	80	1.5
EF95	Efficor	95	1.5
EF105	Efficor	105	1.5



Record Plus Coordination Type 2 at 80kA at 380/400 and 415V

Motor ⁽¹⁾			MCCB					Contactor		Overload relay	Box clamp	Clearance		
Rated power	Rated current (A)		Cat.No.	Rated current (In)	Thermal current	Magnetic setting Im pick-up band ±20% Im	Magnetic current setpoint		Operating current	Admissible power		Setting range	Smallest wire Cu (pvc) ⁽²⁾	Min. frontal electrical safety clearance
kW	380/400V	415V		(A)	Setting range (A)	(A)	(A)	Series	A	P(kW)	Series		380/415V (mm ²)	mm
4	9	8	FD63	12.5	12.5	-	169	EC25A..	25	11	ECRT2	8-12	1.5	20
5.5	12	11	FD63	12.5	12.5	-	169	EC25A..	25	11	ECRT2	10-16	1.5	
7.5	16	14.8	FD63	20	20	-	210	EC25A..	25	11	ECRT2	14.5-18	4	
11	22.5	21	FD63	30	30	-	300	EC32A..	32	15	ECRT3	21-26	6	
15	30	28	FD63	30	30	-	450	EC32A..	32	15	ECRT3	25-35	6	
18.5	37	35	FD63	50	50	-	500	EC40A..	40	18.5		30-40	10	25
22	-	40	FDN36MC050ED	50	-	500-750	580	EF50	50	22	RT2E	30-43	10	
	44	-	FDN36MC050ED	50	-	500-750	580	EF50	50	22	RT2G	42-55	10	
30	60	55	FDN36MC080ED	80	-	800-1200	800	EF65	65	30	RT2H	54-65	16	
37	72	68	FDN36MC080ED	80	-	800-1200	950	EF80	80	37	RT2J	64-82	25	
45	85	80	FDN36MC100ED	100	-	1000-1500	1140	EF95	95	45	RT2L	78-97	35	30
55	105	100	FDN36MC100ED	100	-	1000-1500	1400	EF105	105	55	RT2M	90-110	35	

Record Plus Coordination Type 2 at 80kA at 500/525V

Motor ⁽¹⁾			MCCB					Contactor		Overload relay	Box clamp	Clearance		
Rated power	Rated current (A)		Cat.No.	Rated current (In)	Thermal current	Magnetic setting Im pick-up band ±20% Im	Magnetic current setpoint		Operating current	Admissible power		Setting range	Smallest wire Cu (pvc) ⁽²⁾	Min. frontal electrical safety clearance
kW	500/525V	-		(A)	Setting range (A)	(A)	(A)	Series	A	P(kW)	Series		380/415V (mm ²)	mm
7.5	12	-	FD63	12.5	12.5	-	-	EC32A..	32	15	ECRT2	10-19	4	20
11	18.4	-		20	20	-	-	EC32A..	32	15	ECRT3	17.5-25	6	
15	23	-		30	30	-	-	EC40A..	40	18.5	ECRT3	21-29	6	
18.5	29	-		30	30	-	-	EC40A..	40	18.5	ECRT3	25-35	10	
5.5	9	-	FEL36M012JF	-	-	49-105	117	EF65	65	30	RT4LD	7.5-11	1.5	20
7.5	12	-	FEL36M012JF	-	-	87.5-187.5	156				RT4LE	10-16	1.5	25
11	17	-	FEL36M020JF	-	-	140-300	221	EF95	95	45	RT4LF	12.5-20	2.5	30
15	23	-	FEL36M020JF	-	-	140-300	299				RT4LG	17-27	2.5	
18.5	28.5	-	FEL36M030JF	-	-	240-450	370	EF95	95	45	RT4LH	26-40	4	30
22	33	-	FEL36M030JF	-	-	210-450	429						6	

(1) Current values are relevant to four pole motors not having special characteristics of torque. Inrush currents: ≤ 8 time rated current for ≤ 1s.

(2) The minimum cycle cross-sections are referred to an ambient temperature of 30°C max. in free air and are selected to withstand the maximum let-through energy and the motor rated current. The user also has to consider the drop voltage, the type of laying and ambient temperature.



Surion GPS high breaking capacity (Thermal Magnetic). Coordination Type 2 - 65kA at 380/400 & 415V

Motor ⁽¹⁾			Manual motor starter				Contactor	Box clamp		Links
Rated power	Rated current (A)		Cat.No.	Rated current (In)	Thermal current	Magnetic current	Series	Smallest wire Cu (pvc) ⁽²⁾	Minimum frontal electrical safety clearance	Cat.No.
	380/400V	415V								
0.06	0.23	0.21	GPS1BHAB	0.25	0.16-0.25	3.2	EC9A..	0.75	20	ECM1AL25
0.09	0.34	0.31	GPS1BHAC	0.4	0.25-0.4	5.2	EC9A..	0.75	20	ECM1AL25
0.12	0.44	0.4	GPS1BHAD	0.63	0.4-0.63	8.2	EC9A..	0.75	20	ECM1AL25
0.18	0.65	0.63	GPS1BHAE	1	0.63-1	13	EC9A..	0.75	20	ECM1AL25
0.25	0.9	0.8	GPS1BHAE	1	0.63-1	13	EC9A..	0.75	20	ECM1AL25
0.37	1.25	1.1	GPS1BHAF	1.6	1-1.6	20.5	EC9A..	0.75	20	ECM1AL25
0.55	1.6	1.5	GPS1BHAF	1.6	1-1.6	20.5	EC9A..	0.75	20	ECM1AL25
0.75	2	1.9	GPS1BHAG	2.5	1.6-2.5	32.5	EC9A..	0.75	20	ECM1AL25
1.1	2.6	2.5	GPS1BHAH	4	2.5-4	52	EC9A..	0.75	20	ECM1AL25
1.5	3.5	3.4	GPS1BHAH	4	2.5-4	52	EC9A..	0.75	20	ECM1AL25
2.2	5	4.5	GPS1BHAI	6.3	4-6.3	82	EC9A..	0.75	20	ECM1AL25
3	7	6.5	GPS1BHAK	10	6.3-10	130	EC9A..	1.5	20	ECM1AL25
4	9	8	GPS1BHAK	10	6.3-10	130	EC9A..	1.5	20	ECM1AL25
5.5	12	11	GPS1BHAL	13	9-13	169	EC12A..	2.3	20	ECM1AL25
7.5	16	14	GPS1BHAM	16	11.0-16	208	EC18A..	4	20	ECM1AL25
11	22.5	21	GPS1BHAP	25	19-25	325	EC25A..	6	20	ECM1AL25
15	30	28	GPS1BHAR	32	24-32	416	EC32A..	6	20	ECM1AL32
18.5	37	35	GPS2BHAS	40	28-40	520	EC40A..	10	20	ECM1AL32

Motor ⁽¹⁾			Manual motor starter			Contactor	Overload relay	Box clamp		
Rated power	Rated current (A)		Cat.No.	Rated current (In)	Magnetic current	Series	Series	Setting range	Smallest wire Cu (pvc) ⁽²⁾	Minimum frontal electrical safety clearance
	380/400V	415V								
22	-	40	GPS2MHAT	50	650	EF50	RT2E	30-43	10	25
	44	-					RT2G	42-55		
30	60	55	GPS2MHAU	63	819	EF65	RT2H	54-65	16	

(1) Current values are relevant to four pole motors not having special characteristics of torque. Inrush currents: ≤ 8 time rated current for ≤ 1s.

(2) The minimum cycle cross-sections are referred to an ambient temperature of 30°C max. in free air and are selected to withstand the maximum let-through energy and the motor rated current. The user also has to consider the drop voltage, the type of laying and ambient temperature.



Technical data

Surion GPS-B: Coordination Type 1 65kA at 380/400V and 415V

Rated power (kW)	Motor ⁽¹⁾		Cat. no.	Manual motor starter			Series	Smallest wire Cu (PVC) ⁽²⁾ 380/415V (mm ²)	Minimum frontal electrical safety clearance (mm)	Links Cat. no. ⁽³⁾
	Rated current			Rated current In (A)	Thermal current Setting range (A)	Magnetic current (A)				
	380/400V (A)	415V (A)								
0.06	0.23	0.21	GPS1BSAB	0.25	0.16 - 0.25	3.2	MC0 / CL00	1	20	GPF1LMCBA / GPF1L02#
0.09	0.34	0.31	GPS1BSAC	0.4	0.25 - 0.4	5.2	MC0 / CL00	1	20	GPF1LMCBA / GPF1L02#
0.12	0.44	0.4	GPS1BSAD	0.63	0.4 - 0.63	8.2	MC0 / CL00	1	20	GPF1LMCBA / GPF1L02#
0.18	0.65	0.63	GPS1BSAE	1	0.63 - 1	13	MC0 / CL00	1	20	GPF1LMCBA / GPF1L02#
0.25	0.9	0.8	GPS1BSAE	1	0.63 - 1	13	MC0 / CL00	1	20	GPF1LMCBA / GPF1L02#
0.37	1.25	1.1	GPS1BSAF	1.6	1 - 1.6	20.5	MC0 / CL00	1	20	GPF1LMCBA / GPF1L02#
0.55	1.6	1.5	GPS1BSAF	1.6	1 - 1.6	20.5	MC0 / CL00	1	20	GPF1LMCBA / GPF1L02#
0.75	2	1.9	GPS1BSAG	2.5	1.6 - 2.5	32.5	MC0 / CL00	1	20	GPF1LMCBA / GPF1L02#
1.1	2.6	2.5	GPS1BSAH	4	2.5 - 4	52	MC0 / CL00	1	20	GPF1LMCBA / GPF1L02#
1.5	3.5	3.4	GPS1BSAH	4	2.5 - 4	52	MC0 / CL00	1	20	GPF1LMCBA / GPF1L02#
2.2	5	4.5	GPS1BSAJ	6.3	4 - 6.3	82	MC0 / CL00	1	20	GPF1LMCBA / GPF1L02#
3	7	6.5	GPS1BSAK	10	6.3 - 10	130	MC1 / CL00	1.5	20	GPF1LMCBA / GPF1L02#
4	9	8	GPS1BSAK	10	6.3 - 10	130	MC1 / CL00	1.5	20	GPF1LMCBA / GPF1L02#
5.5	12	11	GPS1BHAL	13	9 - 13	169	CL01	2.5	20	GPF1L02#
7.5	16	14	GPS1BHAM	16	11 - 16	208	CL02	2.5	20	GPF1L02#
11	22.5	21	GPS1BHAP	25	19 - 25	325	CL03	4	20	GPF1L25#
15	30	28	GPS1BHAR	32	24 - 32	416	CL04	6	20	GPF1L04#
11	22.5	21	GPS2BHAP	25	19 - 25	325	CL04	4	20	GPF2L04#
15	30	28	GPS2BHAR	32	24 - 32	416	CL04	6	20	GPF2L04#
18.5	37	35	GPS2BHAS	40	28 - 40	520	CL05	10	20	GPF2L45#
22	44	41	GPS2BHAT	50	35 - 50	650	CL06	10	25	GPF2L07AA
30	60	55	GPS2BHAU	63	45 - 63	820	CL07	16	25	GPF2L07AA

Surion GPS-B: Coordination Type 2 65kA at 380/400V and 415V

Rated power (kW)	Motor ⁽¹⁾		Cat. no.	Manual motor starter			Series	Smallest wire Cu (PVC) ⁽²⁾ 380/415V (mm ²)	Minimum frontal electrical safety clearance (mm)	Links Cat. no. ⁽³⁾
	Rated current			Rated current In (A)	Thermal current Setting range (A)	Magnetic current (A)				
	380/400V (A)	415V (A)								
0.06	0.23	0.21	GPS1BHAB	0.25	0.16 - 0.25	3.2	CL00	1	20	GPF1L02#
0.09	0.34	0.31	GPS1BHAC	0.4	0.25 - 0.4	5.2	CL00	1	20	GPF1L02#
0.12	0.44	0.4	GPS1BHAD	0.63	0.4 - 0.63	8.2	CL00	1	20	GPF1L02#
0.18	0.65	0.63	GPS1BHAE	1	0.63 - 1	13	CL00	1	20	GPF1L02#
0.25	0.9	0.8	GPS1BHAE	1	0.63 - 1	13	CL00	1	20	GPF1L02#
0.37	1.25	1.1	GPS1BHAF	1.6	1 - 1.6	20.5	CL00	1	20	GPF1L02#
0.55	1.6	1.5	GPS1BHAF	1.6	1 - 1.6	20.5	CL00	1	20	GPF1L02#
0.75	2	1.9	GPS1BHAG	2.5	1.6 - 2.5	32.5	CL00	1	20	GPF1L02#
1.1	2.6	2.5	GPS1BHAH	4	2.5 - 4	52	CL03	1	20	GPF1L25#
1.5	3.5	3.4	GPS1BHAH	4	2.5 - 4	52	CL03	1	20	GPF1L25#
2.2	5	4.5	GPS1BHAJ	6.3	4 - 6.3	82	CL03	1	20	GPF1L25#
3	7	6.5	GPS1BHAK	10	6.3 - 10	130	CL03	1.5	20	GPF1L25#
4	9	8	GPS1BHAK	10	6.3 - 10	130	CL03	1.5	20	GPF1L25#
5.5	12	11	GPS1BHAL	13	9 - 13	169	CL03	2.5	20	GPF1L25#
7.5	16	14	GPS1BHAM	16	11 - 16	208	CL03	2.5	20	GPF1L25#
11	22.5	21	GPS1BHAP	25	19 - 25	325	CL03	4	20	GPF1L25#
15	30	28	GPS1BHAR	32	24 - 32	416	CL04	6	20	GPF1L04#
11	22.5	21	GPS2BHAP ⁽⁴⁾	25	19 - 25	325	CL04	4	20	GPF2L04#
15	30	28	GPS2BHAR ⁽⁴⁾	32	24 - 32	416	CL04	6	20	GPF2L04#
18.5	37	35	GPS2BHAS ⁽⁴⁾	40	28 - 40	520	CL05	10	20	GPF2L45#
22	44	41	GPS2BHAT ⁽⁴⁾	50	35 - 50	650	CL06	10	25	GPF2L07#
30	60	55	GPS2BHAU ⁽⁴⁾	63	45 - 63	820	CL07	16	25	GPF2L07#

(1) Currents are relevant to four pole motors not having special characteristics of torque.

Inrush currents: 8 time rated current for 1s.

(2) The minimum cycle cross-sections are referred to an ambient temperature of 30°C max. in free air.

Cables are to withstand the maximum let-through energy and the motor rated current. Besides the user should consider the drop voltage on the cables, the type of laying and the ambient temperature.

(3) Complete cat. nrs., see page D.3

(4) Test running.



Surion GPS-B: Coordination Type 1 50kA at 500V and 525V

Rated power (kW)	Motor ⁽¹⁾		Cat. no.	Manual motor starter			Contactor Series	Smallest wire Cu (PVC) ⁽²⁾ 380/415V (mm ²)	Minimum frontal electrical safety clearance (mm)	Links Cat. no. ⁽³⁾
	Rated current			Rated current In (A)	Thermal current Setting range (A)	Magnetic current (A)				
	500V	525V								
0.06	0.17	0.16	GPS1BSAB	0.25	0.16 - 0.25	3.2	MC0 / CL00	1	20	GPF1LMCBA / GPF1L02#
0.09	0.24	0.22	GPS1BSAB	0.25	0.16 - 0.25	3.2	MC0 / CL00	1	20	GPF1LMCBA / GPF1L02#
0.12	0.33	0.3	GPS1BSAC	0.4	0.25 - 0.4	5.2	MC0 / CL00	1	20	GPF1LMCBA / GPF1L02#
0.18	0.48	0.46	GPS1BSAD	0.63	0.4 - 0.63	8.2	MC0 / CL00	1	20	GPF1LMCBA / GPF1L02#
0.25	0.66	0.64	GPS1BSAE	1	0.63 - 1	13	MC0 / CL00	1	20	GPF1LMCBA / GPF1L02#
0.37	0.9	0.85	GPS1BSAE	1	0.63 - 1	13	MC0 / CL00	1	20	GPF1LMCBA / GPF1L02#
0.55	1.2	1.15	GPS1BSAF	1.6	1 - 1.6	20.5	MC0 / CL00	1	20	GPF1LMCBA / GPF1L02#
0.75	1.5	1.45	GPS1BSAF	1.6	1 - 1.6	20.5	MC0 / CL00	1	20	GPF1LMCBA / GPF1L02#
1.1	2.1	1.9	GPS1BSAG	2.5	1.6 - 2.5	32.5	MC0 / CL00	1	20	GPF1LMCBA / GPF1L02#
1.5	2.8	2.6	GPS1BSAH	4	2.5 - 4	52	MC0 / CL00	1	20	GPF1LMCBA / GPF1L02#
2.2	3.9	3.6	GPS1BSAH	4	2.5 - 4	52	MC0 / CL00	1	20	GPF1LMCBA / GPF1L02#
3	5.3	5	GPS1BSAJ	6.3	4 - 6.3	82	MC0 / CL00	1	20	GPF1LMCBA / GPF1L02#
4	6.8	6.5	GPS1BHAK	10	6.3 - 10	130	MC1 / CL00	1	20	GPF1LMCBA / GPF1L02#
5.5	9.1	8.6	GPS1BHAK	10	6.3 - 10	130	CL00	1.5	20	GPF1L02#
7.5	12	11.4	GPS1BHAL	13	9 - 13	169	CL01	2.5	20	GPF1L02#
10	15.5	14.8	GPS1BHAM	16	11 - 16	208	CL02	2.5	20	GPF1L02#
11	17.6	17	GPS1BHAN	20	14 - 20	260	CL03	2.5	20	GPF1L25#
15	23	22	GPS1BHAP	25	19 - 25	325	CL03	4	20	GPF2L25#
18.5	28.5	27	GPS1BHAR	32	24 - 32	416	CL04	6	20	GPF1L04#
11	17.6	17	GPS2BHAN	20	14 - 20	260	CL04	2.5	20	GPF2L04#
15	23	22	GPS2BHAP	25	19 - 25	325	CL04	4	20	GPF2L04#
18.5	28.5	27	GPS2BHAR	32	24 - 32	416	CL04	6	20	GPF2L04#
22	33	31.5	GPS2BHAS	40	28 - 40	520	CL05	6/10	20	GPF2L45#
30	45	43	GPS2BHAT	50	35 - 50	650	CL06	10	25	GPF2L07#
37	53	52	GPS2BHAU	63	45 - 63	820	CL07	16	25	GPF2L07#

Surion GPS-B: Coordination Type 2 50kA at 500V and 525V

Rated power (kW)	Motor ⁽¹⁾		Cat. no.	Manual motor starter			Contactor Series	Smallest wire Cu (PVC) ⁽²⁾ 380/415V (mm ²)	Minimum frontal electrical safety clearance (mm)	Links Cat. no. ⁽³⁾
	Rated current			Rated current In (A)	Thermal current Setting range (A)	Magnetic current (A)				
	500V	525V								
0.06	0.17	0.16	GPS1BS/HAB	0.25	0.16 - 0.25	3.2	MC1 / CL00	1	20	GPF1LMCBA / GPF1L02#
0.09	0.24	0.22	GPS1BS/HAB	0.25	0.16 - 0.25	3.2	MC1 / CL00	1	20	GPF1LMCBA / GPF1L02#
0.12	0.33	0.3	GPS1BS/HAC	0.4	0.25 - 0.4	5.2	MC1 / CL00	1	20	GPF1LMCBA / GPF1L02#
0.18	0.48	0.46	GPS1BS/HAD	0.63	0.4 - 0.63	8.2	MC1 / CL00	1	20	GPF1LMCBA / GPF1L02#
0.25	0.66	0.64	GPS1BS/HAE	1	0.63 - 1	13	MC1 / CL00	1	20	GPF1LMCBA / GPF1L02#
0.37	0.9	0.85	GPS1BS/HAE	1	0.63 - 1	13	MC1 / CL00	1	20	GPF1LMCBA / GPF1L02#
0.55	1.2	1.15	GPS1BS/HAF	1.6	1 - 1.6	20.5	MC1 / CL00	1	20	GPF1LMCBA / GPF1L02#
0.75	1.5	1.45	GPS1BS/HAF	1.6	1 - 1.6	20.5	MC1 / CL00	1	20	GPF1LMCBA / GPF1L02#
1.1	2.1	1.9	GPS1BS/HAG	2.5	1.6 - 2.5	32.5	CL00	1	20	GPF1L02#
1.5	2.8	2.6	GPS1BS/HAH	4	2.5 - 4	52	CL03	1	20	GPF1L25#
2.2	3.9	3.6	GPS1BS/HAH	4	2.5 - 4	52	CL03	1	20	GPF1L25#
3	5.3	5	GPS1BS/HAJ	6.3	4 - 6.3	82	CL03	1	20	GPF1L25#
4	6.8	6.5	GPS1BHAK	10	6.3 - 10	130	CL03	1	20	GPF1L25#
5.5	9.1	8.6	GPS1BHAK	10	6.3 - 10	130	CL03	1.5	20	GPF1L25#
7.5	12	11.4	GPS1BHAL	13	9 - 13	169	CL03	2.5	20	GPF1L25#
10	15.5	14.8	GPS1BHAM	16	11 - 16	208	CL03	2.5	20	GPF1L25#
11	17.6	17	GPS1BHAN	20	14 - 20	260	CL03	2.5	20	GPF1L25#
15	23	22	GPS1BHAP	25	19 - 25	325	CL04	4	20	GPF1L04#
18.5	28.5	27	GPS1BHAR	32	24 - 32	416	CL04	6	20	GPF1L04#
11	17.6	17	GPS2BHAN	20	14 - 20	260	CL04	2.5	20	GPF2L04#
15	23	22	GPS2BHAP	25	19 - 25	325	CL04	4	20	GPF2L04#
18.5	28.5	27	GPS2BHAR	32	24 - 32	416	CL05	6	20	GPF2L45#
22	33	31.5	GPS2BHAS	40	28 - 40	520	CL06	6/10	25	GPF2L07#
30	45	43	GPS2BHAT	50	35 - 50	650	CL06	10	25	GPF2L07#
37	53	52	GPS2BHAU	63	45 - 63	820	CL07	16	25	GPF2L07#

(1) Currents are relevant to four pole motors not having special characteristics of torque. Inrush currents: 8 time rated current for 1s.
 (2) The minimum cycle cross-sections are referred to an ambient temperature of 30°C max. in free air. Cables are to withstand the maximum let-through energy and the motor rated current. Besides the user should consider the drop voltage on the cables, the type of laying and the ambient temperature.
 (3) Complete cat. nrs., see page D.3



Surion GPS-M and Record Plus: Coordination Type 1 65kA at 380/400V and 415V

Motor ⁽¹⁾			Cat. no.	Breaker			Contactor Series	Overload relay		Smallest wire Cu (PVC) ⁽²⁾ 380/415V (mm ²)	Minimum frontal safety clearance (mm)
Rated power (kW)	Rated current (A)			Rated current I _n (A)	Magnetic setting I _m Pick-up band ±20% I _m (A)	Magnetic current (A)		Series	Setting range		
	380/400V	415V									
0.06	0.23	0.21	GPS1MSAB	0.25	-	3.3	CL00	RT1B	0.16-0.26	1	20
0.09	0.34	0.31	GPS1MSAC	0.4	-	5.2	CL00	RT1C	0.25-0.41	1	20
0.12	0.44	0.4	GPS1MSAD	0.63	-	8.2	CL00	RT1D	0.4-0.65	1	20
0.18	0.65	0.63	GPS1MSAE	1	-	13	CL00	RT1D	0.4-0.65	1	20
0.25	0.9	0.8	GPS1MSAE	1	-	13	CL00	RT1F	0.65-1.1	1	20
0.37	1.25	1.1	GPS1MSAF	1.6	-	20.8	CL00	RT1G	1-1.5	1	20
0.55	1.6	1.5	GPS1MSAF	1.6	-	20.8	CL00	RT1H	1.3-1.9	1	20
0.75	2	1.9	GPS1MSAG	2.5	-	32.5	CL00	RT1J	1.8-2.7	1	20
1.1	2.6	2.5	GPS1MSAH	4	-	52	CL00	RT1K	2.5-4	1	20
1.5	3.5	3.4	GPS1MSAH	4	-	52	CL00	RT1K	2.5-4	1	20
2.2	5	4.5	GPS1MSAJ	6.3	-	81.9	CL00	RT1L	4-6.3	1	20
3	7	6.5	GPS1MSAK	10	-	130	CL00	RT1M	5.5-8.5	1.5	20
4	9	8	GPS1MSAK	10	-	130	CL00	RT1N	8-12	1.5	20
5.5	12	11	GPS1MHAL	13	-	169	CL01	RT1P	10-16	2.5	20
7.5	-	14	GPS1MHAM	16	-	208	CL02	RT1P	10-16	2.5	20
7.5	16	-	GPS1MHAM	16	-	208	CL02	RT1S	14.5-18	2.5	20
11	22.5	21	GPS1MHAP	25	-	325	CL03	RT1U	21-26	4	20
15	30	28	GPS1MHAR	32	-	416	CL04	RT1V	25-32	6	20
11	22.5	21	GPS2MHAP	25	-	325	CL04	RT1U	21-26	4	20
15	30	28	GPS2MHAR	32	-	416	CL04	RT1V	25-32	6	20
18.5	37	35	GPS2MHAS	40	-	520	CL05	RT1W	30-40	10	20
22	-	40	GPS2MHAT	50	-	650	CL06	RT2E	30-43	10	25
22	44	-	GPS2MHAT	50	-	650	CL06	RT2G	42-55	10	25
30	60	55	GPS2MHAU	63	-	819	CL07	RT2H	54-65	16	25
45	85	80	FDH36MC100GD	100	1000 - 1500	1140	CL09	RT2L	78 - 97	35	30
55	-	100	FDH36MC160JF	160	1600 - 2400	1400	CL10	RT2M	90 - 110	35	30
55	105	-	FDH36MC160JF	160	1600 - 240	1400	CL10	RT2M	90 - 110	35	30

Surion GPS-M and Record Plus: Coordination Type 2 65kA at 380/400V and 415V

Motor ⁽¹⁾			Cat. no.	Breaker			Contactor Series	Overload relay		Smallest wire Cu (PVC) ⁽²⁾ 380/415V (mm ²)	Minimum frontal safety clearance (mm)
Rated power (kW)	Rated current (A)			Rated current I _n (A)	Magnetic setting I _m Pick-up band ±20% I _m (A)	Magnetic current (A)		Series	Setting range		
	380/400V	415V									
0.06	0.23	0.21	GPS1MHAB	0.25	-	3.3	CL00	RT1B	0.16-0.26	1	20
0.09	0.34	0.31	GPS1MHAC	0.4	-	5.2	CL00	RT1C	0.25-0.41	1	20
0.12	0.44	0.4	GPS1MHAD	0.63	-	8.2	CL00	RT1D	0.4-0.65	1	20
0.18	0.65	0.63	GPS1MHAE	1	-	13	CL00	RT1D	0.4-0.65	1	20
0.25	0.9	0.8	GPS1MHAE	1	-	13	CL00	RT1F	0.65-1.1	1	20
0.37	1.25	1.1	GPS1MHAF	1.6	-	20.8	CL00	RT1G	1-1.5	1	20
0.55	1.6	1.5	GPS1MHAF	1.6	-	20.8	CL00	RT1H	1.3-1.9	1	20
0.75	2	1.9	GPS1MHAG	2.5	-	32.5	CL00	RT1J	1.8-2.7	1	20
1.1	2.6	2.5	GPS1MHAH	4	-	52	CL03	RT1K	2.5-4	1	20
1.5	3.5	3.4	GPS1MHAH	4	-	52	CL03	RT1K	2.5-4	1	20
2.2	5	4.5	GPS1MHAI	6.3	-	81.9	CL03	RT1L	4-6.3	1	20
3	7	6.5	GPS1MHAK	10	-	130	CL03	RT1M	5.5-8.5	1.5	20
4	9	8	GPS1MHAK	10	-	130	CL03	RT1N	8-12	1.5	20
5.5	12	11	GPS1MHAL	13	-	169	CL03	RT1P	10-16	2.5	20
7.5	-	14	GPS1MHAM	16	-	208	CL03	RT1P	10-16	2.5	20
7.5	16	-	GPS1MHAM	16	-	208	CL03	RT1S	14.5-18	2.5	20
11	22.5	21	GPS2MHAP	25	-	325	CL03	RT1U	21-26	4	20
15	30	28	GPS2MHAR	32	-	416	CL04	RT1V	25-32	6	20
11	22.5	21	GPS2MHAP	25	-	325	CL04	RT1U	21-26	4	20
15	30	28	GPS2MHAR	32	-	416	CL04	RT1V	25-32	6	20
18.5	37	35	GPS2MHAS	40	-	520	CL05	RT1W	30-40	10	20
22	-	40	GPS2MHAT	50	-	650	CL06	RT2E	30-43	10	25
22	44	-	GPS2MHAT	50	-	650	CL06	RT2G	42-55	10	25
30	60	55	GPS2MHAU	63	-	819	CL07	RT2H	54-65	16	25
45	85	80	FDH36MC100GD	100	1000 - 1500	1140	CL09	RT2L	78 - 97	35	30
55	-	100	FDH36MC100GD	100	1000 - 1500	1400	CL10	RT2M	90 - 110	35	30
55	105	-	FDH36MC160JF	160	1600 - 2400	1400	CL10	RT2M	90 - 110	35	30

(1) Currents are relevant to four pole motors not having special characteristics of torque. Inrush currents: H 8 time rated current for H 1s.

(2) The minimum cycle cross-sections are referred to an ambient temperature of 30°C max. in free air and are selected to withstand the maximum let-through energy and the motor rated current. Besides the user has to consider the drop voltage, the type of laying and ambient temperature.



Surion GPS-B: Coordination Type 2 50kA at 380/400V and 415V

Motor ⁽¹⁾			Manual motor starter				Contactor			Links
Rated power (kW)	Rated current		Cat. no.	Rated current In (A)	Thermal current Setting range (A)	Magnetic current (A)	Series	Smallest wire Cu (PVC) ⁽²⁾ 380/415V (mm ²)	Minimum frontal electrical safety clearance (mm)	Cat. no. ⁽³⁾
	380/400V (A)	415V								
0.06	0.23	0.21	GPS1BS/HAB	0.25	0.16 - 0.25	3.2	MC1 / CL00	1	20	GPF1LMCBA / GPF1L02#
0.09	0.34	0.31	GPS1BS/HAC	0.4	0.25 - 0.4	5.2	MC1 / CL00	1	20	GPF1LMCBA / GPF1L02#
0.12	0.44	0.4	GPS1BS/HAD	0.63	0.4 - 0.63	8.2	MC1 / CL00	1	20	GPF1LMCBA / GPF1L02#
0.18	0.65	0.63	GPS1BS/HAE	1	0.63 - 1	13	MC1 / CL00	1	20	GPF1LMCBA / GPF1L02#
0.25	0.9	0.8	GPS1BS/HAE	1	0.63 - 1	13	MC1 / CL00	1	20	GPF1LMCBA / GPF1L02#
0.37	1.25	1.1	GPS1BS/HAF	1.6	1 - 1.6	20.5	MC1 / CL00	1	20	GPF1LMCBA / GPF1L02#
0.55	1.6	1.5	GPS1BS/HAF	1.6	1 - 1.6	20.5	MC1 / CL00	1	20	GPF1LMCBA / GPF1L02#
0.75	2	1.9	GPS1BS/HAG	2.5	1.6 - 2.5	32.5	MC1 / CL00	1	20	GPF1LMCBA / GPF1L02#
1.1	2.6	2.5	GPS1BS/HAH	4	2.5 - 4	52	CL01	1	20	GPF1L02#
1.5	3.5	3.4	GPS1BS/HAH	4	2.5 - 4	52	CL01	1	20	GPF1L02#
2.2	5	4.5	GPS1BS/HAJ	6.3	4 - 6.3	82	CL02	1	20	GPF1L02#
3	7	6.5	GPS1BS/HAK	10	6.3 - 10	130	CL03	1.5	20	GPF1L25#
4	9	8	GPS1BS/HAK	10	6.3 - 10	130	CL03	1.5	20	GPF1L25#
5.5	12	11	GPS1BHAL	13	9 - 13	169	CL03	2.5	20	GPF1L25#
7.5	16	14	GPS1BHAM	16	11 - 16	208	CL03	2.5	20	GPF1L25#
11	22.5	21	GPS1BHAP	25	19 - 25	325	CL03	4	20	GPF1L25#
15	30	28	GPS1BHAR	32	24 - 32	416	CL04	6	20	GPF1L04#
11	22.5	21	GPS2BHAP	25	19 - 25	325	CL04	4	20	GPF2L04#
15	30	28	GPS2BHAR	32	24 - 32	416	CL04	6	20	GPF2L04#
18.5	37	35	GPS2BHAS	40	28 - 40	520	CL05	10	20	GPF2L45#
22	44	41	GPS2BHAT	50	35 - 50	650	CL06	10	25	GPF2L07#
30	60	55	GPS2BHAU	63	45 - 63	820	CL07	16	25	GPF2L07#

(1) Currents are relevant to four pole motors not having special characteristics of torque.

Inrush currents: H 8 time rated current for H 1s.

(2) The minimum cycle cross-sections are referred to an ambient temperature of 30°C max. in free air. Cables are to withstand the maximum let-through energy and the motor rated current. Besides the user should consider the drop voltage on the cables, the type of laying and the ambient temperature.

(3) Complete cat. nrs., see page D.3



Surion GPS-M and Record Plus MCCBs: Coordination Type 1 65kA at 380/400V and 415V

Rated power (kW)	Motor ⁽¹⁾		Cat. no.	Breaker			Contactor Series	Overload relay		Smallest wire Cu (PVC) ⁽²⁾ 380/415V (mm ²)	Minimum frontal safety clearance (mm)
	Rated current			Rated current In (A)	Magnetic setting Im Pick-up band ±20% Im (A)	Magnetic current (A)		Series	Setting range		
	380/400V	415V									
0.06	0.23	0.21	GPS1MS/HAB	0.25	-	3.3	CL00	RT1B	0.16-0.26	1	20
0.09	0.34	0.31	GPS1MS/HAC	0.4	-	5.2	CL00	RT1C	0.25-0.41	1	20
0.12	0.44	0.4	GPS1MS/HAD	0.63	-	8.2	CL00	RT1D	0.4-0.65	1	20
0.18	0.65	0.63	GPS1MS/HAE	1	-	13	CL00	RT1D	0.4-0.65	1	20
0.25	0.9	0.8	GPS1MS/HAE	1	-	13	CL00	RT1F	0.65-1.1	1	20
0.37	1.25	1.1	GPS1MS/HAF	1.6	-	20.8	CL00	RT1G	1-1.5	1	20
0.55	1.6	1.5	GPS1MS/HAF	1.6	-	20.8	CL00	RT1H	1.3-1.9	1	20
0.75	2	1.9	GPS1MS/HAG	2.5	-	32.5	CL00	RT1J	1.8-2.7	1	20
1.1	2.6	2.5	GPS1MS/HAH	4	-	52	CL00	RT1K	2.5-4	1	20
1.5	3.5	3.4	GPS1MS/HAH	4	-	52	CL00	RT1K	2.5-4	1	20
2.2	5	4.5	GPS1MS/HAJ	6.3	-	81.9	CL00	RT1L	4-6.3	1	20
3	7	6.5	GPS1MS/HAK	10	-	130	CL00	RT1M	5.5-8.5	1.5	20
4	9	8	GPS1MS/HAK	10	-	130	CL00	RT1N	8-12	1.5	20
5.5	12	11	GPS1MHAL	13	-	169	CL01	RT1P	10-16	2.5	20
7.5	-	14	GPS1MHAM	16	-	208	CL02	RT1P	10-16	2.5	20
7.5	16	-	GPS1MHAM	16	-	208	CL02	RT1S	14.5-18	2.5	20
11	22.5	21	GPS1MHAP	25	-	325	CL03	RT1U	21-26	4	20
15	30	28	GPS1MHAR	32	-	416	CL04	RT1V	25-32	6	20
11	22.5	21	GPS2MHAP	25	-	325	CL03	RT1U	21-26	4	20
15	30	28	GPS2MHAR	32	-	416	CL04	RT1V	25-32	6	20
18.5	37	35	GPS2MHAS	40	-	520	CL05	RT1W	30-40	10	20
22	-	40	GPS2MHAT	50	-	650	CL06	RT2E	30-43	10	25
22	44	-	GPS2MHAT	50	-	650	CL06	RT2G	42-55	10	25
30	60	55	GPS2MHAU	63	-	819	CL07	RT2H	54-65	16	25
37	72	68	FDN36MC080GD	80	-	950	CL08	RT2J	64-82	25	25
45	85	80	FDN36MC100GD	100	-	1140	CL09	RT2L	78-97	35	30
55	105	100	FDN36MC100GD	100	-	1400	CL10	RT2M	90-110	35	30

Surion GPS-M and Record Plus MCCBs: Coordination Type 2 50kA at 380/400V and 415V

Rated power (kW)	Motor ⁽¹⁾		Cat. no.	Breaker			Contactor Series	Overload relay		Smallest wire Cu (PVC) ⁽²⁾ 380/415V (mm ²)	Minimum frontal safety clearance (mm)
	Rated current			Rated current In (A)	Magnetic setting Im Pick-up band ±20% Im (A)	Magnetic current (A)		Series	Setting range		
	380/400V	415V									
0.06	0.23	0.21	GPS1MS/HAB	0.25	-	3.3	CL00	RT1B	0.16-0.26	1	20
0.09	0.34	0.31	GPS1MS/HAC	0.4	-	5.2	CL00	RT1C	0.25-0.41	1	20
0.12	0.44	0.4	GPS1MS/HAD	0.63	-	8.2	CL00	RT1D	0.4-0.65	1	20
0.18	0.65	0.63	GPS1MS/HAE	1	-	13	CL00	RT1D	0.4-0.65	1	20
0.25	0.9	0.8	GPS1MS/HAE	1	-	13	CL00	RT1F	0.65-1.1	1	20
0.37	1.25	1.1	GPS1MS/HAF	1.6	-	20.8	CL00	RT1G	1-1.5	1	20
0.55	1.6	1.5	GPS1MS/HAF	1.6	-	20.8	CL00	RT1H	1.3-1.9	1	20
0.75	2	1.9	GPS1MS/HAG	2.5	-	32.5	CL00	RT1J	1.8-2.7	1	20
1.1	2.6	2.5	GPS1MS/HAH	4	-	52	CL01	RT1K	2.5-4	1	20
1.5	3.5	3.4	GPS1MS/HAH	4	-	52	CL01	RT1K	2.5-4	1	20
2.2	5	4.5	GPS1MS/HAJ	6.3	-	81.9	CL02	RT1L	4-6.3	1	20
3	7	6.5	GPS1MS/HAK	10	-	130	CL03	RT1M	5.5-8.5	1.5	20
4	9	8	GPS1MS/HAK	10	-	130	CL03	RT1N	8-12	1.5	20
5.5	12	11	GPS1MHAL	13	-	169	CL03	RT1P	10-16	1.5	20
7.5	-	14	GPS1MHAM	16	-	208	CL03	RT1P	10-16	2.5	20
7.5	16	-	GPS1MHAM	16	-	208	CL03	RT1S	14.5-18	2.5	20
11	22.5	21	GPS1MHAP	25	-	325	CL03	RT1U	21-26	4	20
15	30	28	GPS1MHAR	32	-	416	CL04	RT1V	25-32	6	20
11	22.5	21	GPS2MHAP	25	-	325	CL04	RT1U	21-26	4	20
15	30	28	GPS2MHAR	32	-	416	CL04	RT1V	25-32	6	20
18.5	37	35	GPS2MHAS	40	-	520	CL05	RT1W	30-40	6	20
22	-	40	GPS2MHAT	50	-	650	CL06	RT2E	30-43	10	25
22	44	-	GPS2MHAT	50	-	650	CL06	RT2G	42-55	10	25
30	60	55	GPS2MHAU	63	-	819	CL07	RT2H	54-65	16	25
37	72	68	FDN36MC080GD	80	-	950	CL08	RT2J	64-82	25	25
45	85	80	FDN36MC100GD	100	-	1140	CL09	RT2L	78-97	35	30
55	105	100	FDN36MC100GD	100	-	1400	CL10	RT2M	90-110	35	30

(1) Currents are relevant to four pole motors not having special characteristics of torque. Inrush currents: H 8 time rated current for H 1s.

(2) The minimum cycle cross-sections are referred to an ambient temperature of 30°C max. in free air and are selected to withstand the maximum let-through energy and the motor rated current. Besides the user has to consider the drop voltage, the type of laying and ambient temperature.



Surion GPS-M and Record Plus MCCBs: Coordination Type 1 50kA at 500 and 525V

Rated power (kW)	Motor ⁽¹⁾		Cat. no.	Breaker			Contactor Series	Overload relay		Smallest wire Cu (PVC) ⁽²⁾ 380/415V (mm ²)	Minimum frontal safety clearance (mm)
	Rated current			Rated current In (A)	Magnetic setting Im Pick-up band ±20% Im (A)	Magnetic current (A)		Series	Setting range		
	500V	525V									
0.06	0.17	0.16	GPS1MSAB	0.25	-	3.2	CL00	RT1B	0.16-0.26	1	20
0.09	0.24	0.22	GPS1MSAB	0.25	-	3.2	CL00	RT1B	0.16-0.26	1	20
0.12	0.33	0.3	GPS1MSAC	0.4	-	5.2	CL00	RT1C	0.25-0.41	1	20
0.18	0.48	0.46	GPS1MSAD	0.63	-	8.2	CL00	RT1D	0.4-0.65	1	20
0.25	-	0.64	GPS1MSAE	1	-	13	CL00	RT1D	0.4-0.65	1	20
0.25	0.66	-	GPS1MSAE	1	-	13	CL00	RT1F	0.65-1.1	1	20
0.37	0.9	0.85	GPS1MSAE	1	-	13	CL00	RT1F	0.65-1.1	1	20
0.55	1.2	1.15	GPS1MSAF	1.6	-	20.5	CL00	RT1G	1.0-1.5	1	20
0.75	1.5	1.45	GPS1MSAF	1.6	-	20.5	CL00	RT1H	1.3-1.9	1	20
1.1	2.1	1.9	GPS1MSAG	2.5	-	32.5	CL00	RT1J	1.8-2.7	1	20
1.5	2.8	2.6	GPS1MSAH	4	-	52	CL00	RT1K	2.5-4	1	20
2.2	3.9	3.6	GPS1MSAH	4	-	52	CL00	RT1K	2.5-4	1	20
3	5.3	5	GPS1MSAJ	6.3	-	82	CL00	RT1L	4.0-6.3	1	20
4	6.8	6.5	GPS1MHHAK	10	-	130	CL00	RT1M	5.5-8.5	1	20
5.5	9.1	8.6	GPS1MHHAK	10	-	130	CL00	RT1N	8.0-12.0	1.5	20
7.5	12	11.4	GPS1MHHAL	13	-	169	CL01	RT1P	10-16	2.5	20
10	15.5	14.8	GPS1MHHAM	16	-	208	CL02	RT1S	14.5-18	2.5	20
11	17.6	17	GPS1MHHAN	20	-	260	CL03	RT1S	14.5-18	2.5	20
15	23	22	GPS1MHHAP	25	-	325	CL03	RT1U	21-26	4	20
18.5	28.5	27	GPS1MHHAR	32	-	416	CL04	RT1V	25-32	6	20
11	17.6	17	GPS2MHHAN	20	-	260	CL04	RT1S	14.5-18	2.5	20
15	23	22	GPS2MHHAP	25	-	325	CL04	RT1U	21-26	4	20
18.5	28.5	27	GPS2MHHAR	32	-	416	CL04	RT1V	25-32	6	20
22	33	31.5	GPS2MHHAS	40	-	520	CL05	RT2E	30-43	6/10	20
30	45	43	GPS2MHHAT	50	-	650	CL06	RT2G	42-55	10	25
37	53	52	GPS2MHHAU	63	-	820	CL07	RT2G	42-55	16	25
45	-	62	FDN36MC080GD	80	800 - 1200	1000	CL08	RT2H	54 - 65	16	30
45	65	-	FDN36MC080GD	80	800 - 1200	1000	CL08	RT2J	64 - 82	25	30
55	80	76	FDN36MC100GD	100	1000 - 1500	1200	CL09	RT2J	64 - 82	25	30

Surion GPS-M and Record Plus MCCBs: Coordination Type 2 50kA at 500 and 525V

Rated power (kW)	Motor ⁽¹⁾		Cat. no.	Breaker			Contactor Series	Overload relay		Smallest wire Cu (PVC) ⁽²⁾ 380/415V (mm ²)	Minimum frontal safety clearance (mm)
	Rated current			Rated current In (A)	Magnetic setting Im Pick-up band ±20% Im (A)	Magnetic current (A)		Series	Setting range		
	500V	525V									
0.06	0.17	0.16	GPS1MS/HAB	0.25	-	3.2	CL00	RT1B	0.16-0.26	1	20
0.09	0.24	0.22	GPS1MS/HAB	0.25	-	3.2	CL00	RT1B	0.16-0.26	1	20
0.12	0.33	0.3	GPS1MS/HAC	0.4	-	5.2	CL00	RT1C	0.25-0.41	1	20
0.18	0.48	0.46	GPS1MS/HAD	0.63	-	8.2	CL00	RT1D	0.4-0.65	1	20
0.25	-	0.64	GPS1MS/HAE	1	-	13	CL00	RT1D	0.4-0.65	1	20
0.25	0.66	-	GPS1MS/HAE	1	-	13	CL00	RT1F	0.65-1.1	1	20
0.37	0.9	0.85	GPS1MS/HAE	1	-	13	CL00	RT1F	0.65-1.1	1	20
0.55	1.2	1.15	GPS1MS/HAF	1.6	-	20.5	CL00	RT1G	1.0-1.5	1	20
0.75	1.5	1.45	GPS1MS/HAF	1.6	-	20.5	CL00	RT1H	1.3-1.9	1	20
1.1	2.1	1.9	GPS1MS/HAG	2.5	-	32.5	CL01	RT1J	1.8-2.7	1	20
1.5	2.8	2.6	GPS1MS/HAH	4	-	52	CL03	RT1K	2.5-4	1	20
2.2	3.9	3.6	GPS1MS/HAH	4	-	52	CL03	RT1K	2.5-4	1	20
3	5.3	5	GPS1MS/HAJ	6.3	-	82	CL03	RT1L	4.0-6.3	1	20
4	6.8	6.5	GPS1MHHAK	10	-	130	CL03	RT1M	5.5-8.5	1	20
5.5	9.1	8.6	GPS1MHHAK	10	-	130	CL03	RT1N	8.0-12	1.5	20
7.5	12	11.4	GPS1MHHAL	13	-	169	CL03	RT1P	10-16	2.5	20
10	15.5	14.8	GPS1MHHAM	16	-	208	CL03	RT1S	14.5-18	2.5	20
11	17.6	17	GPS1MHHAN	20	-	260	CL03	RT1S	14.5-18	2.5	20
15	23	22	GPS1MHHAP	25	-	325	CL04	RT1U	21-26	4	20
18.5	28.5	27	GPS1MHHAR	32	-	416	CL04	RT1V	25-32	6	20
11	17.6	17	GPS2MHHAN	20	-	260	CL04	RT1S	14.5-18	2.5	20
15	23	22	GPS2MHHAP	25	-	325	CL04	RT1U	21-26	4	20
18.5	28.5	27	GPS2MHHAR	32	-	416	CL05	RT1V	25-32	6	20
22	33	31.5	GPS2MHHAS	40	-	520	CL06	RT2E	30-43	6/10	25
30	45	43	GPS2MHHAT	50	-	650	CL06	RT2G	42-55	10	25
37	53	52	GPS2MHHAU	63	-	820	CL07	RT2G	42-55	16	25
45	-	62	FDN36MC080GD	80	800 - 1200	1000	CL09	RT2H	54 - 65	16	30
45	65	-	FDN36MC080GD	80	800 - 1200	1000	CL09	RT2J	64 - 82	25	30
55	80	76	FDN36MC100GD	100	1000 - 1500	1200	CL10	RT2J	64 - 82	25	30

(1) Currents are relevant to four pole motors not having special characteristics of torque. Inrush currents: H 8 time rated current for H 1s.

(2) The minimum cycle cross-sections are referred to an ambient temperature of 30°C max. in free air and are selected to withstand the maximum let-through energy and the motor rated current. Besides the user has to consider the drop voltage, the type of laying and ambient temperature.



Surion GPS-M and Record Plus MCCBs: Coordination Type 1 50kA at 500 and 525V

Rated power (kW)	Motor Rated current		Motor protection circuit breaker			Contactor	Thermal relay
	380/400V	415V	Cat. no.	Setting range I _n	Magnetic setting I _m	Series	Class 10
	(A)	(A)		(A)	(A)		
0.25	0.9	0.8	GPS1BHAE	0.63-1	13	CL00	Integrated into the motor protection circuit breaker
0.37	1.25	1.1	GPS1BHAF	1-1.6	20.5	CL00	Integrated into the motor protection circuit breaker
0.55	1.6	1.5	GPS1BHAF	1-1.6	20.5	CL00	Integrated into the motor protection circuit breaker
0.75	2	1.9	GPS1BHAG	1.6-2.5	32.5	CL00	Integrated into the motor protection circuit breaker
1.1	2.6	2.5	GPS1BHAH	2.5-4	52	CL03	Integrated into the motor protection circuit breaker
1.5	3.5	3.45	GPS1BHAH	2.5-4	52	CL03	Integrated into the motor protection circuit breaker
2.2	5	4.7	GPS1BHAI	4-6.3	82	CL03	Integrated into the motor protection circuit breaker
3	7	6.5	GPS1BHAK	6.3-10	130	CL03	Integrated into the motor protection circuit breaker
4	9	8	GPS1BHAK	6.3-10	130	CL03	Integrated into the motor protection circuit breaker
5.5	12	11	GPS1BHAL	9.0-13	169	CL03	Integrated into the motor protection circuit breaker
7.5	16	14	GPS1BHAM	11.0-16	208	CL03	Integrated into the motor protection circuit breaker
11	22.5	21	GPS1BHAP	19-25	325	CL03	Integrated into the motor protection circuit breaker
15	30	28	GPS1BHAR	24-32	416	CL04	Integrated into the motor protection circuit breaker
18.5	37	35	GPS2BHAS	28-40	520	CL05	Integrated into the motor protection circuit breaker
22	44	41	GPS2BHAT	25-50	650	CL06	Integrated into the motor protection circuit breaker
30	60	55	GPS2BHAU	45-63	820	CL07	Integrated into the motor protection circuit breaker
37	72.5	65	FDH36MC080	80	950	CL08	RT2J (64-82A)
45	85	79	FDH36MC100	100	1140	CL09	RT2L (78-97A)

Surion GPS-B and Record Plus MCCBs: Coordination Type 2 80kA at 380/400V and 415V

Rated power (kW)	Motor Rated current		Motor protection circuit breaker			Contactor	Thermal relay
	380/400V	415V	Cat. no.	Setting range I _n	Magnetic setting I _m	Series	Class 10
	(A)	(A)		(A)	(A)		
0.25	0.9	0.8	GPS1BHAE	0.63-1	13	CL00	Integrated into the motor protection circuit breaker
0.37	1.25	1.1	GPS1BHAF	1-1.6	20.5	CL00	Integrated into the motor protection circuit breaker
0.55	1.6	1.5	GPS1BHAF	1-1.6	20.5	CL00	Integrated into the motor protection circuit breaker
0.75	2	1.9	GPS1BHAG	1.6-2.5	32.5	CL00	Integrated into the motor protection circuit breaker
1.1	2.6	2.5	GPS1BHAH	2.5-4	52	CL03	Integrated into the motor protection circuit breaker
1.5	3.5	3.45	GPS1BHAH	2.5-4	52	CL03	Integrated into the motor protection circuit breaker
2.2	5	4.7	GPS1BHAI	4-6.3	82	CL03	Integrated into the motor protection circuit breaker
3	7	6.5	GPS1BHAK	6.3-10	130	CL03	Integrated into the motor protection circuit breaker
4	9	8	GPS1BHAK	6.3-10	130	CL03	Integrated into the motor protection circuit breaker
5.5	12	11	GPS1BHAL	9.0-13	169	CL05	Integrated into the motor protection circuit breaker
7.5	16	14	FDH36MC020	20	210	CL04	RT1S (14.5-18A)
11	22.5	21	FDH36MC030	30	300	CL05	RT1U (21-26A)
15	30	28	FDH36MC030	30	450	CL05	RT1V (25-32A)
18.5	37	35	FDH36MC050	50	500	CL05	RT1W (30-40A)
22	44	41	FDH36MC050	50	580	CL06	RT2G (42-55A)
30	66	55	FDH36MC080	80	800	CL07	RT2H (54-65A)
37	72.5	65	FDH36MC080	80	950	CL08	RT2J (64-82A)
45	85	79	FDH36MC100	100	1140	CL09	RT2L (78-97A)



Record Plus MCCBs: Coordination Type 2 150kA at 380/400V and 415V (Class 10 protection)

Motor ⁽¹⁾			Thermal-magnetic circuit breaker					Contactor		
Rated power (kW)	Rated current		Cat. no.	Magnetic setting I _m Pick-up band ±20% I _m (A)	Magnetic current (A)	Magnetic current (A)	Thermal setpoint (400V) (A)	Series	Smallest wire Cu (PVC) ⁽²⁾ 380/415V (mm ²)	Minimum frontal safety clearance (mm)
	380/400V (A)	415V (A)								
7.5	16	14	FD•36TD016ED	160	160	12.8 - 16	16	CL05	2.5	20
11	22.5	21	FD•36TD025ED	250	250	20 - 25	22.5	CL05	4	20
15	30	28	FD•36TD032ED	320	320	26 - 32	30	CL05	6	20
18.5	37	35	FD•36TD040ED	400	400	32 - 40	37	CL05	10	20
22	44	40	FD•36TD050ED	500	500	40 - 50	40	CL06	10	25
30	60	55	FD•36TD063ED	630	630	50 - 63	55	CL07	16	25
37	72	68	FD•36TD080GD	800	800	64 - 80	68	CL08	25	25
45	85	80	FD•36TD100GD	1000	1000	80 - 100	80	CL09	35	30
55	105	100	FD•36TD125GD	1250	1250	100 - 125	100	CL10	35	30
75	138	135	FD•36TD160GD	1280	1280	128 - 160	135	CK75	50	40
90	170	165	FE•36TD200KF	1000 - 2000	1700	160 - 200	165	CK08	70	40
110	211	200	FE•36TD250KF	1250 - 2500	2100	200 - 250	200	CK85	95	40
132	245	240	FE•36TD250KF	1250 - 2500	2500	200 - 250	240	CK09	120	40

(•) Max I_q rating in kA: type N = 50 kA, type H = 80 kA, type L = 150 kA.

- (1) Currents are relevant to four pole motors not having special characteristics of torque.
Inrush currents: H 8 times rated current for H 1s (Normal starting) or H 5s (Heavy starting).
- (2) The minimum cycle cross-sections are referred to an ambient temperature of 30°C max. in free air and are selected to withstand the maximum let-through energy and the motor rated current. Besides the user has to consider the drop voltage, the type of laying and ambient temperature.
- (3) Foreseen values for E-frame.

Intro

A

B

C

D

E

F

G

H

I

X



Record Plus MCCBs: Coordination Type 2 Up to 150kA at 380/400V and 415V (Class 10 protection)

Rated power (kW)	Motor ⁽¹⁾		Only magnetic circuit breaker			Contactor	Overload relay		Smallest wire Cu (PVC) ⁽²⁾ 380/415V (mm ²)	Minimum frontal safety clearance (mm)
	Rated current		Cat. no.	Magnetic setting Im Pick-up band ±20% Im (A)	Magnetic current Setpoint (A)	Series	Series	Setting range		
	380/400V (A)	415V								
4	9	8	FD•36MC012ED	125 - 188	120	CL04	RT1N	8 - 12	1,5	20
5.5	12	11	FD•36MC012ED	125 - 188	150	CL04	RT1P	10 - 16	2,5	20
7.5	-	14	FD•36MC020ED	200 - 300	200	CL04	RT1P	10 - 16	2,5	20
7.5	16	-	FD•36MC020ED	200 - 300	210	CL04	RT1S	14,5 - 18	2,5	20
11	22,5	21	FD•36MC030ED	300 - 450	450	CL05	RT1U	21 - 26	4	20
15	30	28	FD•36MC030ED	300 - 450	500	CL05	RT1V	25 - 32	6	20
18.5	37	35	FD•36MC050ED	500 - 750	500	CL05	RT1W	30 - 40	10	20
22	-	40	FD•36MC050ED	500 - 750	540	CL06	RT2E	30 - 43	10	25
22	44	-	FD•36MC050ED	500 - 750	580	CL06	RT2G	42 - 55	10	25
30	60	55	FD•36MC080GD	800 - 1200	800	CL07	RT2H	54 - 65	16	25
37	72	68	FD•36MC080GD	800 - 1200	950	CL08	RT2J	64 - 82	25	25
45	85	80	FD•36MC100GD	1000 - 1500	1140	CL09	RT2L	78 - 97	35	30
55	-	100	FD•36MC100GD	1000 - 1500	1400	CL10	RT2M	90 - 110	35	30
55	105	-	FE•36MC160JF	1600 - 2400	1400	CL10	RT2M	90 - 110	35	30
75	138	135	FE•36MC160JF	1600 - 2400	1900	CK75	RT3E	110 - 140	50	40
90	170	165	FE•36MC250KF	2500 - 3750	2500	CK08	RT3F	140 - 190	70	40
110	211	200	FE•36MC250KF	2500 - 3750	2800	CK85	RT4P	175 - 280	95	40
132	245	240	FE•36MC250KF	2500 - 3750	3150	CK09	RT4P	175 - 280	120	40

Record Plus MCCBs: Coordination Type 2 Up to 150kA at 380/400V and 415V (Class 30 protection)

Rated power (kW)	Motor ⁽¹⁾		Only magnetic circuit breaker			Contactor	Overload relay		Smallest wire Cu (PVC) ⁽²⁾ 380/415V (mm ²)	Minimum frontal safety clearance (mm)
	Rated current		Cat. no.	Magnetic setting Im Pick-up band ±20% Im (A)	Magnetic current Setpoint (A)	Series	Series	Setting range		
	380/400V (A)	415V								
2.2	5	4.5	FD•36MC008ED	80 - 120	80	CL03	RT4LB	4 - 6.5	1,5	20
3	7	6.5	FD•36MC008ED	80 - 120	90	CL04	RT4LC	5.5 - 8.5	1,5	20
4	9	8	FD•36MC012ED	125 - 188	120	CL04	RT4GLD	7.5 - 11	1,5	20
5.5	12	11	FD•36MC012ED	125 - 188	150	CL05	RT4LE	10 - 16	2,5	20
7.5	-	14	FD•36MC020Ed	200 - 300	200	CL05	RT4LE	10 - 16	2,5	20
7.5	16	-	FD•36MC020ED	200 - 300	210	CL05	RT4LF	12,5 - 20	2,5	20
11	22,5	21	FD•36MC030ED	300 - 450	450	CL05	RT4LG	17 - 27	4	20
15	30	28	FD•36MC030ED	300 - 450	500	CL05	RT4LH	26 - 40	6	20
18.5	37	35	FD•36MC050ED	500 - 750	500	CL06	RT4LH	26 - 40	10	25
22	-	40	FD•36MC050ED	500 - 750	540	CL06	RT4LJ	32 - 52	10	25
22	44	-	FD•36MC050ED	500 - 750	580	CL06	RT4LJ	32 - 52	10	25
30	60	55	FD•36MC080GD	800 - 1200	800	CL07	RT4LK	45 - 70	16	25
37	72	68	FD•36MC080GD	800 - 1200	950	CL08	RT4LL	60 - 90	25	25
45	85	80	FD•36MC100GD	1000 - 1500	1140	CL09	RT4LL	60 - 90	35	30
55	-	100	FD•36MC100GD	1000 - 1500	1400	CL10	RT4LM	80 - 125	35	30
55	105	-	FE•36MC160JF	1600 - 2400	1400	CL10	RT4LM	80 - 125	35	30
75	138	135	FE•36MC160JF	1600 - 2400	1900	CK75	RT4LN	120 - 190	50	40a
90	170	165	FE•36MC250KF	2500 - 3750	2500	CK08	RT4LN	120 - 190	70	40
110	211	200	FE•36MC250KF	2500 - 3750	2800	CK85	RT4LR	200 - 310	95	40
132	245	240	FE•36MC250KF	2500 - 3750	3150	CK09	RT4LR	200 - 310	120	40

(•) Max Iq rating in kA: type N = 50 kA, type H = 80 kA, type L = 150 kA.

(1) Current are relevant to four pole motors not having special characteristics of torque.

Inrush currents: H 8 times rated current for H 1s (Normal starting) or H 5s (Heavy starting).

(2) The minimum cycle cross-sections are referred to an ambient temperature of 30°C max. in free air and are selected to withstand the maximum let-through energy and the motor rated current. Besides the user has to consider the drop voltage, the type of laying and ambient temperature.

(3) Foreseen values for E-frame.



Coordination Type 2 - 65kA at 380/400V and 415V - 50/60Hz

Motor ⁽¹⁾			Breaker				Contactor	Overload relay		Wire	
Rated power (kW)	Rated current		Cat. no. #	Rated current In (A)	Magnetic setting 1m Pick-up ±20% Im (A)	Magnetic current (A)	Series	Series	Setting range (A)	Smallest wire Cu (PVC) ⁽²⁾ (mm ²)	Min frontal safety (mm)
	380/400V (A)	415V									
0.06	0.23	0.21	GPS1MHAB	0.25	-	3.3	CL00	RE1D	0.1-0.5	1	20
0.09	0.34	0.31	GPS1MHAC	0.4	-	5.2	CL00	RE1D	0.1-0.5	1	20
0.12	0.44	0.4	GPS1MHAD	0.63	-	8.2	CL00	RE1D	0.1-0.5	1	20
0.18	0.65	0.63	GPS1MHA E	1	-	13	CL00	RE1H	0.4-2.0	1	20
0.25	0.9	0.8	GPS1MHA E	1	-	13	CL00	RE1H	0.4-2.0	1	20
0.37	1.25	1.1	GPS1MHA F	1.6	-	20.8	CL00	RE1H	0.4-2.0	1	20
0.55	1.6	1.5	GPS1MHA F	1.6	-	20.8	CL00	RE1H	0.4-2.0	1	20
0.75	2	1.9	GPS1MHA G	2.5	-	32.5	CL00	RE1K	1.5-5.0	1	20
1.1	2.6	2.5	GPS1MHA H	4	-	52	CL03	RE1K	1.5-5.0	1	20
1.5	3.5	3.4	GPS1MHA H	4	-	52	CL03	RE1K	1.5-5.0	1	20
2.2	5	4.5	GPS1MHA J	6.3	-	81.9	CL03	RE1K	1.5-5.0	1	20
3	7	6.5	GPS1MHA K	10	-	130	CL03	RE1M	1.6-8.0	1.5	20
4	9	8	GPS1MHA K	10	-	130	CL03	RE1S	6.4-32.0	1.5	20
5.5	12	11	GPS1MHA L	13	-	169	CL03	RE1S	6.4-32.0	2.5	20
7.5	-	14	GPS1MHA M	16	-	208	CL03	RE1S	6.4-32.0	2.5	20
8.8	16	-	GPS1MHA M	16	-	208	CL03	RE1S	6.4-32.0	2.5	20
11	22.5	21	GPS1MHA P	25	-	325	CL03	RE1S	6.4-32.0	4	20
15	30	28	GPS1MHA R	32	-	416	CL04	RE1S	6.4-32.0	6	20
11	22.5	21	GPS2MHA R	25	-	325	CL04	RE1S	6.4-32.0	4	20
15	30	28	GPS2MHA P	32	-	416	CL04	RE1S	6.4-32.0	6	20
18.5	37	35	GPS2MHA S	40	-	520	CL05	RE1W	9.0-45.0	10	20
22	-	40	GPS2MHA T	50	-	650	CL07	RE2H	15.0-75.0	10	25
30	44	--	GPS2MHA T	50	-	650	CL07	RE2H	15.0-75.0	10	25
30	60	55	GPS2MHA U	63	-	819	CL07	RE2H	15.0-75.0	16	25
35	65	60	FDH36MC080GD	80	900-1300	1100	CL08	RE2H	15.0-75.0	25	25
45	85	80	FDH36MC1 OOGD	100	1000-1500	1400	CL09	RE2M	22.0-110.0	25	30
55	-	100	FDH36MC1 OOGD	100	1000-1500	1400	CL10	RE2M	22.0-110.0	25	30
55	105	-	FEH36MC125JF	125	1250-1875	1250	CL10	RE2M	22.0-110.0	25	30
75	138	135	FEH36MC200KF	200	2250-3350	2800	CK75	RE3E	30.0-150.0	50	40

Coordination tables

Coordination Type 2 - 100kA at 500 - 525V - 50/60Hz

Motor ⁽¹⁾			gL/gG Fuses		EOL			Contactor		Wire	
Rated power kW	Rated current		Size In (A)	Series	Type	Setting range (A)	Series	PAC3 (kW)	Seco min	Safety clearance (mm)	
	500V (A)	525V									
0.06	0.17	0.16	2	000	RE1	D	0.1-0.5	CL00	5.5	1	20
0.03	0.24	0.22	2	000	RE1	D	0.1-0.5	CL00	5.5	1	20
0.12	0.33	0.3	2	000	RE1	D	0.1-0.5	CL00	5.5	1	20
0.18	0.48	0.46	2	000	RE1	D	0.1-0.5	CL00	5.5	1	20
0.25	0.66	0.64	2	000	RE1	H	0.4-2.0	CL00	5.5	1	20
0.37	0.3	0.85	4	000	RE1	H	0.4-2.0	CL00	5.5	1	20
0.55	1.2	1.15	4	000	RE1	H	0.4-2.0	CL00	5.5	1	20
0.75	1.5	1.45	4	000	RE1	H	0.4-2.0	CL00	5.5	1	20
1.1	2.1	1.3	6	000	RE1	K	1.5-5.0	CL00	5.5	1	20
1.5	2.8	2.6	10	000	RE1	K	1.5-5.0	CL00	5.5	1	20
1.1	2.1	1.3	6	000	RE1	K	1.5-5.0	CL01	7.5	1	20
1.5	2.8	2.6	10	000	RE1	K	1.5-5.0	CL01	7.5	1	20
2.2	3.3	3.6	10	000	RE1	K	1.5-5.0	CL01	7.5	1	20
1.5	2.8	2.6	10	000	RE1	K	1.5-5.0	CL03	15	1	20
2.2	3.3	3.6	10	000	RE1	K	1.5-5.0	CL03	15	1	20
3	5.3	5	16	000	RE1	M	1.6-8.0	CL03	15	1	20
4	6.8	6.5	20	000	RE1	M	1.6-8.0	CL03	15	1	20
5.5	3.1	8.6	25	000	RE1	S	6.4-32.0	CL03	15	1.5	20
7.5	12	11.4	32	000	RE1	S	6.4-32.0	CL03	15	2.5	20
10	15.5	14.8	40	000	RE1	S	6.4-32.0	CL03	15	2.5	20
11	17.6	17	40	000	RE1	S	6.4-32.0	CL03	15	2.5	20
15	23	22	50	000	RE1	S	6.4-32.0	CL04	18.5	4	20
18.5	28.5	27	63	000	RE1	S	6.4-32.0	CL04	18.5	6	20
4	6.8	6.5	20	000	RE1	M	1.6-8.0	CL05	25	1.5	20
5.5	3.1	8.6	25	000	RE1	S	6.4-32.0	CL05	25	2.5	20
7.5	12	11.4	32	000	RE1	S	6.4-32.0	CL05	25	2.5	20
11	17.6	17	40	000	RE1	S	6.4-32.0	CL05	25	2.5	20
15	23	22	50	000	RE1	S	6.4-32.0	CL05	25	4	20
18.5	28.5	27	63	000	RE1	W	3.0-45.0	CL05	25	5	20
22	33	31.5	80	000	RE1	H	15.0-75.0	CL05	25	5	20
18.5	28.5	27	63	000	RE2	H	15.0-75.0	CL07	30	5	25
22	33	31.5	80	000	RE2	H	15.0-75.0	CL07	30	5	25
30	45	43	80	000	RE2	H	15.0-75.0	CL07	30	10	25
37	53	52	100	000	RE2	H	15.0-75.0	CL07	40	10	25
40	53	56	100	000	RE2	H	15.0-75.0	CL08	45	16	25
45	65	62	125	00	RE2	H	15.0-75.0	CL09	55	16	30
55	80	76	125	00	RE2	M	22.0-110.0	CL10	65	25	30
75	105	100	160	01/1	RE3	E	30.0-150.0	CK75	100	35/25	40
30	130	124	250	01/1	RE3	E	30.0-150.0	CK08	110	50	40

(1) Current are relevant to four pole motors not having special characteristics of torque.

(2) The minimum cycle cross-sections are referred to an ambient temperature of 30°C max. in free air and are selected to withstand the maximum let-through energy and the motor rated current. Besides the user has to consider the drop voltage, the type of laying and ambient temperature if it is different.



Intro

A

B

C

D

E

F

G

H

I

X

Everything is under control

IE3 Ready

One of the earth's biggest challenges is to reduce CO₂ emissions. Consequently there are new regulatory standards to reduce energy consumption. IEC60034-30-1 defines the efficiency classes for induction motors. From January 1st 2017 efficiency classes IE3 (premium efficiency) for motors from 0.75 up to 375kW or IE2 (high efficiency) motor with a drive, will become mandatory.

Although IE3 compliant motors consume less energy than IE2 motors, IE3 motors draw higher inrush and starting currents. IE3 motors have been in the market for several years and the starting behavior varies between designers and manufacturers. On average the inrush peak starting current will increase by 20% and the locked motor current by 15% versus a standard IE2 motor.

When selecting a starter to protect and control an IE3 motor, special care has to be taken in order to avoid unwanted tripping of the short circuit protection. The median ratio between the Inrush peak and the motor rated current increases from 10.2 (IE2 motors) to 12.6 (IE3 motors). GE recommends a ratio of 14 in order to account for the spread on motor data. For a ratio below 14 the motor datasheet has to be checked.

Efficor starting solutions provides a complete portfolio to Switch and Protect Premium Efficiency IE3 motors

- Efficor contactors have been specifically designed to switch higher starting currents and can be used without constraint in DOL, star-delta and reversing starting applications.
- ECRT, RT2 and RE relays protect the motor against overloads. IE3 motor rated operating current need to be within the OL relay setting range.
- Surion MMS are designed to protect motors and provide line protection against overload and short-circuit. They need to be selected to allow a higher inrush current to avoid nuisance tripping during start.

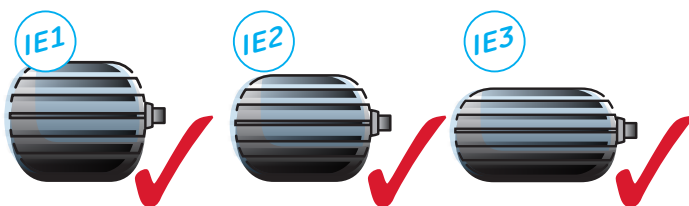
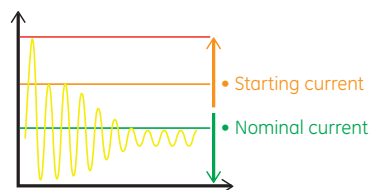

Selection Table for Direct-On-Line starters

Values given are a harmonized IEC guideline between rated operational currents and rated operational powers determined on the basis of a four-pole squirrel-cage induction motor

Selection Table

Power	Guide values of rated operational current (A) at							Contactor	Overload Protection ⁽⁴⁾		Breaker ⁽⁵⁾		
	kW ⁽¹⁾	hp ⁽²⁾	110-120V	220-240V ⁽¹⁾	380-415V ⁽¹⁾	440-480V	500V		690V	Effcor		TOR	RE
Applications	1/2	4.4	2.2	1.3	1.1			0.87	EC09	ECRT1B10G	RE1H	GPS1_F	
				EC09					ECRT1B10G	RE1H	GPS1_F		
				EC09					ECRT1B10J	RE1K	GPS1_G		
	0.55	3/4	6.4	3.2	1.5 ⁽³⁾	1.6 ⁽³⁾		1.2	1.1	EC09	ECRT1B10L	RE1M	GPS1_J
					EC09					ECRT1B10F	RE1H	GPS1_E	
					EC09					ECRT1B10G	RE1H	GPS1_F	
					EC09					ECRT1B10G	RE1H	GPS1_F	
					EC09					ECRT1B10K	RE1K	GPS1_H	
					EC09					ECRT1B10H	RE1H	GPS1_F	
	0.75	1.1	6.4	3.2	1.8	1.6 ⁽³⁾		1.5	1.1	EC09	ECRT1B10J	RE1H	GPS1_G
					EC09					ECRT1B10K	RE1K	GPS1_H	
					EC09					ECRT1B10M	RE1S	GPS1_K	
EC09					ECRT1B10G					RE1H	GPS1_F		
EC09					ECRT1B10G					RE1H	GPS1_F		
EC09					ECRT1B10J					RE1H	GPS1_G		
1.1	1-1/2	12	6 ⁽³⁾	1.9	3		2.2	1.6 ⁽³⁾	EC09	ECRT1B10J	RE1H	GPS1_G	
				EC09					ECRT1B10K	RE1K	GPS1_H		
				EC09					ECRT1B10L	RE1M	GPS1_J		
				EC09					ECRT1B10K	RE1K	GPS1_H		
				EC09					ECRT1B10K	RE1K	GPS1_H		
				EC09					ECRT1B10L	RE1M	GPS1_J		
1.5	2	13.6	6.8	2.7	3.4		2.9	2.1	EC09	ECRT1B10L	RE1M	GPS1_J	
				EC09					ECRT1B10K	RE1K	GPS1_H		
				EC09					ECRT1B10L	RE1M	GPS1_J		
				EC09					ECRT1B10M	RE1S	GPS1_K		
				EC18					ECRT1B10P	RE1S	GPS1_M		
				EC09					ECRT1B10J	RE1K	GPS1_G		
2.2	3	19.2	9.6	3.3	4.8		3.9 ⁽³⁾	2.8	EC09	ECRT1B10K	RE1K	GPS1_H	
				EC09					ECRT1B10L	RE1M	GPS1_J		
				EC09					ECRT1B10K	RE1K	GPS1_H		
				EC09					ECRT1B10L	RE1M	GPS1_J		
				EC09					ECRT1B10K	RE1K	GPS1_H		
				EC09					ECRT1B10L	RE1M	GPS1_J		
3	4	30.4 ⁽³⁾	15.2 ⁽³⁾	4.3	7.6		5.2	3.8 ⁽³⁾	EC09	ECRT1B10L	RE1M	GPS1_J	
				EC09					ECRT1B10K	RE1K	GPS1_H		
				EC09					ECRT1B10M	RE1S	GPS1_K		
				EC09					ECRT1B10L	RE1M	GPS1_J		
				EC09					ECRT1B10M	RE1S	GPS1_K		
				EC12					ECRT1B10N	RE1S	GPS1_L		
5.5	7-1/2	44	22	4.9	11		9.2	6.7	EC09	ECRT1B10M	RE1S	GPS1_K	
				EC09					ECRT1B10M	RE1S	GPS1_K		
				EC09					ECRT1B10M	RE1S	GPS1_K		
				EC18					ECRT1B10P	RE1S	GPS1_M		
				EC32					ECRT2B10V	RE1W	GPS1_R		
				EC09					ECRT1B10M	RE1S	GPS1_K		
Intro	A			6.5	11.5		11	6.7	EC12	ECRT1B10N	RE1S	GPS1_L	
				EC25					ECRT2B10T	RE1S	GPS1_P		
				EC12					ECRT1B10N	RE1S	GPS1_L		
				EC25					ECRT2B10T	RE1S	GPS1_P		
				EC12					ECRT1B10N	RE1S	GPS1_L		
				EC18					ECRT1B10P	RE1S	GPS1_M		
B	B			14	11		9.2	6.7	EC25	ECRT2B10T	RE1S	GPS1_P	
				EC12					ECRT1B10N	RE1S	GPS1_L		
				EC18					ECRT1B10P	RE1S	GPS1_M		
				EC25					ECRT2B10T	RE1S	GPS1_P		
				EC12					ECRT1B10N	RE1S	GPS1_L		
				EF50					RT2G	RE2M	GPS2_U		

(1) Preferred rated values according to IEC 60072-1 (primary series). 230V and 400V are the rated voltage for IEC.
 (2) Horsepower and currents values according to UL 508 (60Hz).
 (3) Inrush peak versus the motor rated current median is 12.6 for IE3 motors. The ratio on these breakers is in the range from 13 to 14 times. Motor datasheet has to be checked. In case of higher inrush current than the average select next range of available breaker.
 (4) Overload protection: Choose thermal (TOR) or electronic (RE) overload protection device.
 (5) Choose thermo-magnetic or only magnetic breaker characteristic:
 Optimized DOL starter: Breaker (thermomagnetic) + Contactor.
 Conventional DOL starter: Breaker (only magnetic) + Contactor + Overload.



Power		Guide values of rated operational current (A) at						Contactor	Overload Protection ⁽⁴⁾		Breaker ⁽⁵⁾			
kW ⁽¹⁾	hp ⁽²⁾	110-120V	220-240V ⁽³⁾	380-415V ⁽¹⁾	440-480V	500V	690V	Effcor	TOR	RE	Surion			
10	10	56	28	18	14	12.4	8.9	EC18	ECRT1B10P	RE1S	GPS1_M			
				18	14			EC18	ECRT1B10S	RE1S	GPS1_N			
				18	14			EC32	ECRT2B10V	RE1W	GPS1_R			
7.5	7.5	56	27	15.5 ⁽³⁾	17.6	12.4	8.9	EF65	RT2H	RE2M	GPS2_U			
				15.5 ⁽³⁾				17.6	12.4	8.9	EC12	ECRT1B10N	RE1S	GPS1_K
				15.5 ⁽³⁾							EC18	ECRT1B10P	RE1S	GPS1_M
11	11	56	27	22	17.6	12.4	8.9	EC18	ECRT1B10P	RE1S	GPS1_M			
				22				17.6	12.8	8.9	EC32	ECRT2B10V	RE1W	GPS1_R
				22							EC25	ECRT2B10P	RE1S	GPS1_M
15	15	84	42	27	21	17.6	12.8	EC18	ECRT1B10S	RE1S	GPS1_N			
				27				21	12.8	12.8	EC25	ECRT2B10T	RE1S	GPS1_P
				27							EC40	ECRT2B10W	RE1W	GPS2_S
20	20	84	42	38 ⁽³⁾	21	17.6	12.8	EC25	ECRT2B10T	RE1S	GPS1_P			
				38 ⁽³⁾				21	12.8	12.8	EC32	ECRT2B10V	RE1W	GPS1_R
				38 ⁽³⁾							EF50	RT2G	RE2M	GPS2_T
15	15	84	42	34	27	17.6	12.8	EF95	RT2L	RE2M ⁽⁶⁾	FD-36MC100GD			
				34				27	12.8	12.8	EC32	ECRT2B10V	RE1W	GPS1_R
				34							EC40	ECRT2B10W	RE1W	GPS2_S
15	15	84	42	54	27	17.6	12.8	EF65	RT2H	RE2M	GPS2_U			
				54				27	12.8	12.8	EC25	ECRT2B10S	RE1S	GPS1_N
				54							EC25	ECRT2B10U	RE1S	GPS1_P
18.5	18.5	84	42	29	27	17.6	12.8	EC32	ECRT2B10V	RE1W	GPS1_R			
				29				27	12.8	12.8	EF65	RT2G	RE2M	GPS2_U
				29							EF65	RT2G	RE2M	GPS2_U
25	25	84	42	35	27	17.6	12.8	EC32	ECRT2B10T	RE1S	GPS1_P			
				35				27	12.8	12.8	EC32	ECRT2B10V	RE1W	GPS1_R
				35							EC40	ECRT2B10W	RE1W	GPS2_S
22	22	84	42	34	27	17.6	12.8	EF65	RT2H	RE2M	GPS2_U			
				34				27	12.8	12.8	EC40	ECRT2B10W	RE1W	GPS2_S
				34							EF80	RT2J	RE2M ⁽⁶⁾	FD-36MC080GD
30	30	84	42	44	27	17.6	12.8	EC40	ECRT2B10U	RE1W	GPS1_R			
				44				27	12.8	12.8	EC40	ECRT2B10W	RE1W	GPS2_S
				44							EF50	RT2E	RE2M	GPS2_T
30	30	84	42	40 ⁽³⁾	27	17.6	12.8	EF80	RT2J	RE2M	FD-36MC080GD			
				40 ⁽³⁾				27	12.8	12.8	EC40	ECRT2B10W	RE1W	GPS2_S
				40 ⁽³⁾							EF65	RT2G	RE2M	GPS2_U
40	40	84	42	51	27	17.6	12.8	EF80	RT2J	RE2M	FD-36MC080GD			
				51				27	12.8	12.8	EF65	RT2G	RE2M	GPS2_U
				51							EF80	RT2J	RE2M	FD-36MC080GD
30	30	84	42	61 ⁽³⁾	27	17.6	12.8	EF65	RT2G	RE2M	GPS2_U			
				61 ⁽³⁾				27	12.8	12.8	EF80	RT2J	RE2M	FD-36MC080GD
				61 ⁽³⁾							EF105	RT2M	RE2M	FE-36MC125JF
37	37	84	42	55	27	17.6	12.8	EF50	RT2E	RE2M	GPS2_S			
				55				27	12.8	12.8	EF50	RT2G	RE2M	GPS2_U
				55							EF65	RT2H	RE2M	GPS2_U
50	50	84	42	66	27	17.6	12.8	EF105	RT2M	RE2M ⁽⁶⁾	FE-36MC125JF			
				66				27	12.8	12.8	EF50	RT2G	RE2M	GPS2_U
				66							EF65	RT2G	RE2M	GPS2_U
60	60	84	42	66	27	17.6	12.8	EF80	RT2J	RE2M	FD-36MC080GD			
				66				27	12.8	12.8	EF80	RT2J	RE2M	FD-36MC080GD
				66							EF80	RT2J	RE2M	FD-36MC080GD
45	45	84	42	83	27	17.6	12.8	EF80	RT2J	RE2M	FD-36MC080GD			
				83				27	12.8	12.8	EF80	RT2J	RE2M	FD-36MC080GD
				83							EF105	RT2M	RE2M	FE-36MC125JF
55	55	84	42	103	27	17.6	12.8	EF50	RT2G	RE2M	GPS2_U			
				103				27	12.8	12.8	EF65	RT2J	RE2M	FD-36MC080GD
				103							EF80	RT2L	RE2M	FD-36MC080GD
75	75	84	42	80	27	17.6	12.8	EF80	RT2L	RE2M	FD-36MC080GD			
				80				27	12.8	12.8	EF65	RT2H	RE2M	GPS2_U
				80							EF80	RT2L	RE2M ⁽⁶⁾	FD-36MC080GD
75	75	84	42	97	27	17.6	12.8	EF105	RT2M	RE2M ⁽⁶⁾	FE-36MC125JF			
				97				27	12.8	12.8	EF80	RT2L	RE2M ⁽⁶⁾	FD-36MC080GD
				97							EF105	RT2M	RE2M ⁽⁶⁾	FE-36MC125JF
90	90	84	42	96	27	17.6	12.8	EF80	RT2J	RE2M	FD-36MC080GD			
				96				EF95	RT2M	RE2M	FD-36MC100GD			

(1) Preferred rated values according to IEC 60072-1 (primary series). 230V and 400V are the rated voltage for IEC.
 (2) Horsepower and currents values according to UL 508 (60Hz).
 (3) Inrush peak versus the motor rated current median is 12.6 for IE3 motors. The ratio on these breakers is in the range from 13 to 14 times. Motor datasheet has to be checked. In case of higher inrush current than the average select next range of available breaker.
 (4) Overload protection: Choose thermal (TOR) or electronic (RE) overload protection device.
 (5) Choose thermo-magnetic or only magnetic breaker characteristic:
 Optimized DOL starter: Breaker (thermomagnetic) + Contactor.
 Conventional DOL starter: Breaker (only magnetic) + Contactor + Overload.
 (6) When used together with FE breaker, replace by RE3E separate mounting from contactor.



Direct-on-line starters

- Motors connected directly on-line with a contactor and a thermal overload relay.
- Simple installation with high starting torque and current.
- For use with motors of medium power that do not need a progressive star

AC-3	Switching off motors during running	$I_c = I_e$
AC-4	Switching off motors during starting	$I_c = 6 I_e$

Torque-speed curve

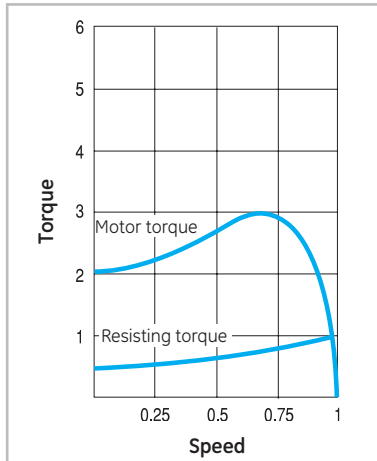

Current-speed curve

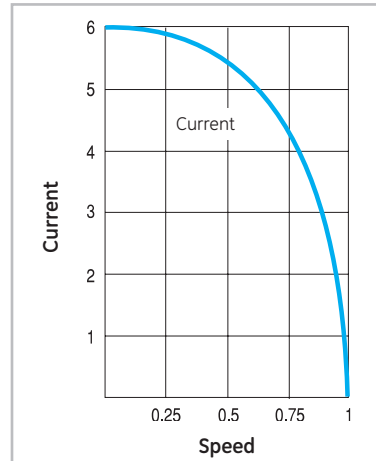

Direct-on-line starter

Power circuit

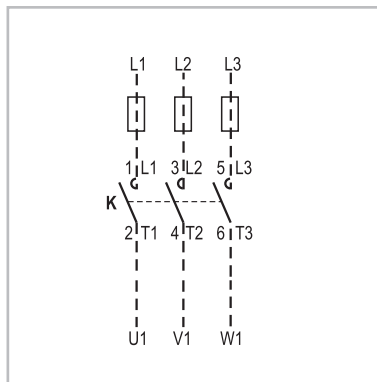

Control circuit

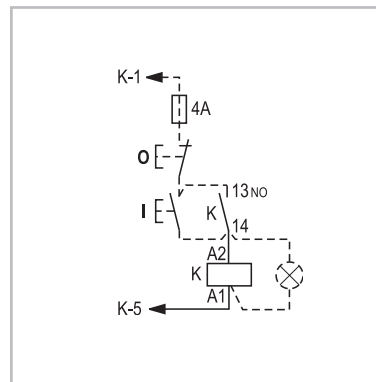

Control by two or more push-buttons

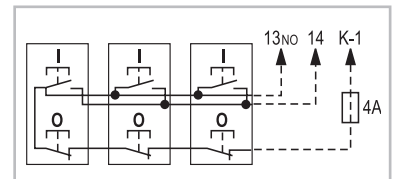

Control by permanent contact

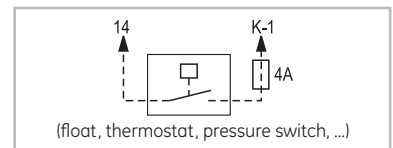

Direct-on-line starter with reset push-button

Power circuit

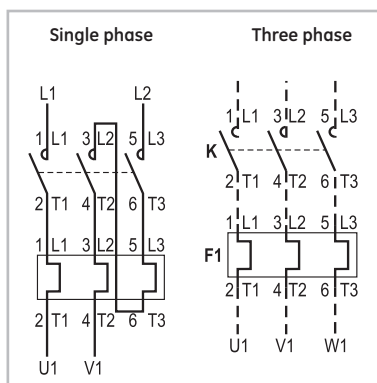

Control circuit

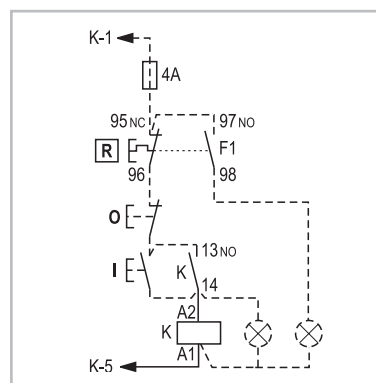

Control by two or more push-buttons

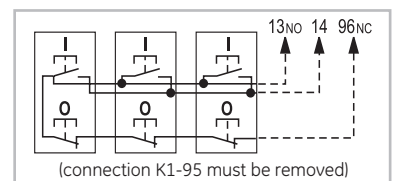

Control by permanent contact

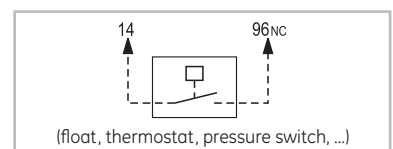

Direct-on-line starter with start/stop/reset push-button

Power circuit

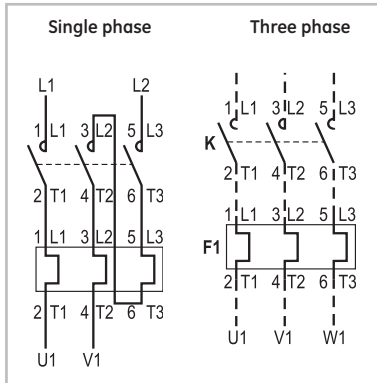

Control circuit

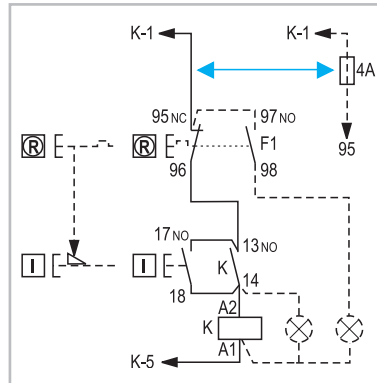

Control by two or more push-buttons

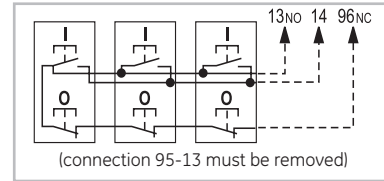

Control by permanent contact

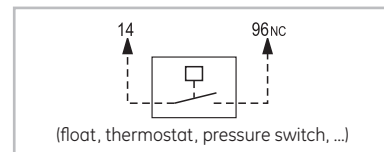

Reversing starter without thermal overload relay

Power circuit

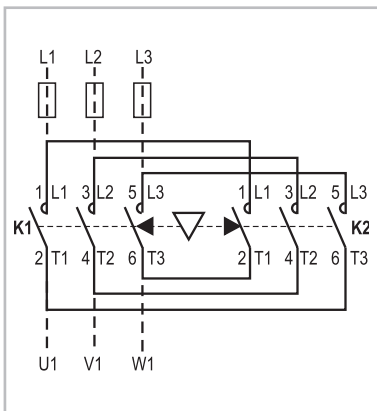

Control circuit

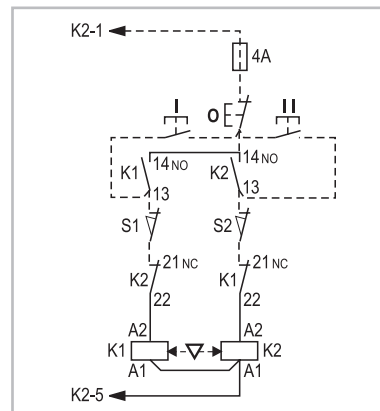

Control by two or more push-buttons

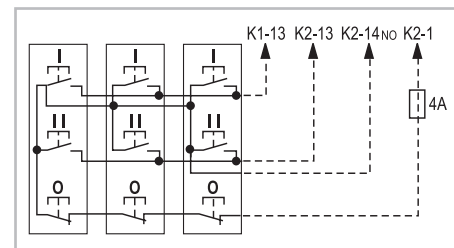

Reversing starter with thermal overload relay

Power circuit

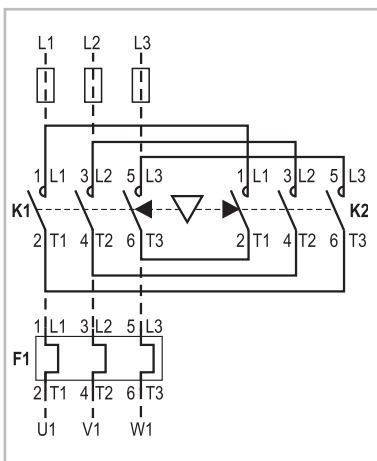

Control circuit

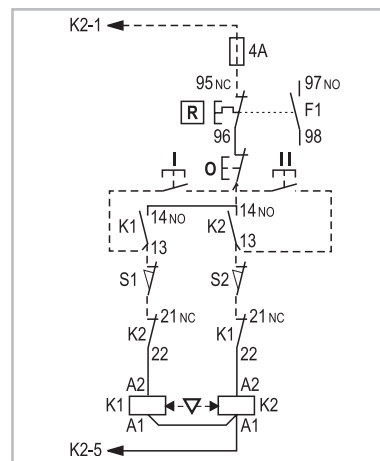

Control by two or more push-buttons

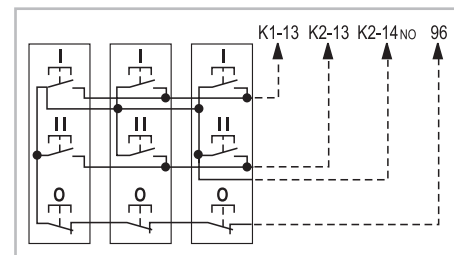

Direct-on-line starters

Selection table

		Motor										Contactor	Thermal relay	Fuse			
		230/200V		400/380V		440/415V		500V		690/660V				1000V		aM	gG-gL
		kW	A	kW	A	kW	A	kW	A	kW	A	kW	A	A	A		
		-	-	-	-	-	-	-	-	0.06	0.13	-	-	MC0	MT03A	0.5	1
		-	-	0.06	0.23	0.06	0.21	0.06	0.17	0.09	0.2	-	-		MT03B	0.5	1
		-	-	-	-	-	-	-	-	0.12	0.25	-	-		MT03B	0.5	1
		0.06	0.39	0.09	0.34	0.09	0.31	0.09	0.26	0.18	0.35	-	-		MT03C	1	2
		-	-	-	-	0.12	0.4	0.12	0.33	-	-	-	-		MT03C	1	2
		0.09	0.58	0.12	0.44	-	-	0.18	0.46	0.25	0.46	-	-		MT03D	1	2
		-	-	0.18	0.61	0.18	0.56	0.25	0.6	-	-	-	-		MT03D	1	2
		-	-	-	-	-	-	-	-	0.37	0.7	-	-		MT03E	2	4
		0.12	0.76	0.25	0.78	0.25	0.7	0.37	0.9	0.55	0.9	-	-		MT03E	2	4
		0.18	1.05	0.37	1.13	0.37	1.1	0.55	1.2	0.75	1.1	-	-		MT03F	2	4
		0.25	1.4	-	-	-	-	-	-	-	-	-	-		MT03G	2	4
		-	-	0.55	1.6	0.55	1.5	0.75	1.5	1.1	1.5	-	-		MT03H	4	6
		0.37	2	0.75	2	0.75	2	1.1	2	1.5	2	-	-		MT03I	4	6
		-	-	1.1	2.6	1.1	2.5	1.5	2.6	-	-	-	-		MT03J	4	6
		0.56	2.75	-	-	-	-	-	-	2.2	2.9	-	-		MT03J	4	6
		0.75	3.5	1.5	3.5	1.5	3.4	2.2	3.8	3	3.5	-	-		MT03K	6	10
		1.1	5	2.2	5	2.2	4.5	3	5	-	-	-	-		MT03L	10	16
		1.5	7	-	-	-	-	-	-	-	-	-	-		MT03M	10	16
		-	-	-	-	-	-	-	-	3.7	4.6	-	-	MC1	MT03L	10	16
		-	-	-	-	-	-	-	-	4	5	-	-		MT03L	10	16
		-	-	3	7	3	6.5	3.7	6	-	-	-	-		MT03M	10	16
		-	-	-	-	3.7	7.3	4	6.5	-	-	-	-		MT03M	10	16
		-	-	3.7	8	4	8	-	-	-	-	-	-		MT03N	12	20
		2.2	9	4	9	-	-	-	-	-	-	-	-		MT03N	12	20
		-	-	-	-	-	-	-	-	5.5	6.7	-	-	MC2	MT03M	12	20
		-	-	-	-	-	-	5.5	9	-	-	-	-		MT03N	16	20
		3	12	5.5	12	5.5	11	-	-	-	-	-	-		MT03P	16	20
		-	-	0.06	0.23	0.06	0.21	0.06	0.17	0.09	0.2	-	-	EC09	ECRT1B10B	2	4
		-	-	-	-	-	-	0.09	0.26	0.12	0.25	-	-		ECRT1B10C	2	4
		0.06	0.39	0.09	0.34	0.09	0.31	0.12	0.33	0.18	0.35	-	-		ECRT1B10C	2	4
		0.09	0.58	0.12	0.44	0.12	0.4	0.18	0.46	0.25	0.46	-	-		ECRT1B10D	2	4
		-	-	0.18	0.61	0.18	0.56	0.25	0.6	-	-	-	-		ECRT1B10D	2	4
		-	-	-	-	-	-	-	-	0.37	0.7	-	-		ECRT1B10F	2	4
		0.12	0.76	0.25	0.78	0.25	0.7	0.37	0.9	0.55	0.9	-	-		ECRT1B10F	2	4
		0.18	1.05	0.37	1.13	0.37	1.1	0.55	1.2	0.75	1.1	-	-		ECRT1B10G	2	4
		0.25	1.4	0.55	1.6	0.55	1.5	0.75	1.5	1.1	1.5	-	-		ECRT1B10H	2	6
		0.37	2	0.75	2	0.75	2	1.1	2	1.5	2	-	-		ECRT1B10J	4	6
		0.55	2.75	1.1	2.6	1.1	2.5	1.5	2.6	2.2	2.9	-	-		ECRT1B10K	4	6
		0.75	3.5	1.5	3.5	1.5	3.4	2.2	3.8	-	-	-	-		ECRT1B10K	6	10
		-	-	-	-	-	-	-	-	3.7	4.6	-	-		ECRT1B10L	6	16
		1.1	5	2.2	5	2.2	4.5	-	-	-	-	-	-		ECRT1B10L	6	16
		1.5	7	-	-	3.7	7.3	3.7	6	5.5	7	-	-		ECRT1B10M	10	20
		-	-	3.7	8	-	-	-	-	-	-	-	-		ECRT1B10M	12	25
		2.2	9	4	9	4	9	5.5	9	-	-	-	-		ECRT1B10N	16	25
		-	-	-	-	-	-	-	-	7.5	9	-	-	EC12	ECRT1B10N	16	25
		3	12	5.5	12	5.5	11	7.5	12	-	-	-	-		ECRT1B10P	16	35
		3.7	14	-	-	7.5	14	-	-	-	-	-	-	EC18	ECRT1B10P	20	40
		4	16	7.5	16	-	-	10	15.5	-	-	-	-		ECRT1B10S	20	40
		-	-	-	-	-	-	-	-	11	13	-	-	EC25	ECRT1B10P	20	40
		-	-	-	-	-	-	11	17	13	16	-	-		ECRT1B10S	20	40
		5.5	21	-	-	11	21	13	20	-	-	-	-		ECRT1B10T	32	50
		-	-	11	22.5	-	-	15	23	-	-	-	-		ECRT2B10U	32	50

(continued on page D.27)

Direct-on-line starters

Intro

A

B

C

D

E

F

G

H

I

X



Selection table (continued 1)

Motor										Contactor	Thermal relay	Fuse			
230/200V		400/380V		440/415V		500V		690/660V				1000V		aM	gG-gL
kW	A	kW	A	kW	A	kW	A	kW	A	kW	A	A	A		
-	-	-	-	-	-	-	-	17	20	-	-	EC32	ECRT2B10T	32	50
7.5	27	15	30	15	28	17.5	26.5	-	-	-	-	EC32	ECRT2B10V	40	63
-	-	-	-	-	-	-	-	18.5	23	-	-	EC32	ECRT2B10U	32	50
-	-	-	-	-	-	-	-	-	22	25	-	EC40	ECRT2B10V	40	63
-	-	-	-	-	-	18.5	28.5	-	-	-	-	EC40	ECRT2B10V	40	63
-	-	18.5	37	18.5	35	22	33	-	-	-	-	EC40	ECRT2B10W	50	80
-	-	-	-	-	-	25	37.5	30	35	-	-	EC40	ECRT2B10W	50	80
11	40	-	-	22	40	-	-	-	-	-	-	EF50	RT2E (1)	50	80
-	-	-	-	-	-	-	-	33	38	-	-	EF50	RT2E	50	80
-	-	22	44	25	45	-	-	-	-	-	-	EF50	RT2G	63	80
15	50	-	-	-	-	-	-	-	-	-	-	EF50	RT2G	63	80
-	-	-	-	-	-	-	-	37	41	-	-	EF65	RT2E	63	80
-	-	-	-	-	-	30	45	40	43	-	-	EF65	RT2G	63	80
-	-	30	60	30	55	37	55	-	-	-	-	EF65	RT2H	80	125
18.5	65	-	-	37	66	-	-	-	-	-	-	EF65	RT2J	80	125
-	-	-	-	-	-	-	-	45	49	-	-	EF80	RT2G	80	125
-	-	37	72	-	-	45	65	-	-	-	-	EF80	RT2J	100	125
22	75	-	-	-	-	-	-	-	-	-	-	EF80	RT2J	100	125
-	-	-	-	45	80	-	-	-	-	-	-	EF80	RT2L	100	160
-	-	-	-	-	-	-	-	55	60	-	-	EF95	RT2H	80	125
-	-	-	-	-	-	50	73	-	-	-	-	EF95	RT2J	100	125
25	84	45	85	50	88	55	80	-	-	-	-	EF95	RT2L	100	160
30	105	55	105	55	100	-	-	-	-	-	-	EF105	RT2M	125	200
-	-	-	-	-	-	-	-	-	-	55	40	CK75	RT4J	63	80
-	-	-	-	-	-	-	-	75	80	-	-	CK75	RT3C	125	160
-	-	-	-	-	-	-	-	90	97	-	-	CK75	RT3D	125	160
-	-	-	-	-	-	75	105	-	-	-	-	CK75	RT3D	160	200
37	126	-	-	-	-	-	-	-	-	-	-	CK75	RT3E	160	200
-	-	75	138	75	135	90	129	-	-	-	-	CK75	RT3E	200	224
45	150	-	-	-	-	-	-	-	-	-	-	CK75	RT3F	200	224
-	-	-	-	-	-	-	-	-	-	75	54	CK08	RT4 K	80	125
-	-	-	-	-	-	-	-	-	-	90	64	CK08	RT3B	100	160
-	-	-	-	-	-	-	-	110	118	-	-	CK08	RT3E	160	200
-	-	-	-	-	-	-	-	132	141	-	-	CK08	RT3F	200	250
-	-	90	170	90	165	110	156	-	-	-	-	CK08	RT3F	200	250
55	182	-	-	100	182	-	-	-	-	-	-	CK08	RT3F	200	250
-	-	-	-	-	-	-	-	-	-	110	78	CK85	RT4L (1)	100	160
-	-	-	-	-	-	-	-	150	166	-	-	CK85	RT4N (1)	250	315
-	-	-	-	110	200	132	188	-	-	-	-	CK85	RT4P (1)	250	315
-	-	110	211	-	-	-	-	-	-	-	-	CK85	RT4P (1)	250	315
-	-	-	-	-	-	-	-	-	-	132	94	CK09	RT4M (1)	125	160
-	-	-	-	-	-	-	-	-	-	150	105	CK09	RT4M (1)	160	200
-	-	-	-	-	-	-	-	160	170	-	-	CK09	RT4N (1)	200	250
-	-	-	-	-	-	-	-	185	193	-	-	CK09	RT4P (1)	250	315
-	-	-	-	-	-	-	-	-	-	160	113	CK95	RT4M (1)	160	200
-	-	-	-	-	-	-	-	-	-	185	130	CK95	RT4N (1)	160	200
-	-	-	-	-	-	-	-	-	-	200	141	CK95	RT4N (1)	200	250
-	-	-	-	-	-	-	-	-	-	220	155	CK10	RT5A (1)	200	250
-	-	-	-	-	-	-	-	-	-	250	175	CK10	RT5A (1)	250	315
-	-	-	-	-	-	-	-	220	230	-	-	CK95	RT4P (1)	315	400
-	-	-	-	150	269	185	261	250	262	-	-	CK95	RT4R (1)	355	400
-	-	150	283	160	285	-	-	-	-	-	-	CK95	RT4R (1)	400	425
90	309	160	309	-	-	200	281	-	-	-	-	CK95	RT4R (1)	400	425

(1) Separate mounting: type RT2XP.

(continued on page D.28)

Direct-on-line starters

Intro

A

B

C

D

E

F

G

H

I

X



Selection table (continued 2)

Motor										Contactor	Thermal relay	Fuse				
230/200V		400/380V		440/415V		500V		690/660V				1000V		aM	gG-gL	
kW	A	kW	A	kW	A	kW	A	kW	A	kW	A	A	A			
-	-	-	-	-	-	220	310	280	292	-	-	CK10	RT5C	400	425	
-	-	-	-	185	325	-	-	300	307	-	-		RT5C	425	500	
-	-	-	-	-	-	-	-	315	322	-	-		RT5C	425	500	
110	356	185	355	200	350	250	348	335	344	-	-		RT5D	425	500	
-	-	220	370	220	385	-	-	355	366	-	-		RT5D	500	500	
-	-	-	-	-	-	280	385	375	390	-	-		RT5D	500	500	
-	-	220	408	-	-	300	409	-	-	-	-		RT5D	500	500	
-	-	-	-	-	-	-	-	-	-	280	197		CK11	RT5B	250	315
-	-	-	-	-	-	-	-	-	-	300	211			RT5B	315	355
-	-	-	-	-	-	-	-	-	-	315	221			RT5B	315	355
-	-	-	-	-	-	-	-	-	-	335	234	RT5B		315	355	
-	-	-	-	-	-	-	-	-	-	355	245	RT5B		315	355	
-	-	-	-	-	-	-	-	400	412	-	-	RT5D		500	500	
132	425	-	-	250	437	315	426	-	-	-	-	RT5D		630	630	
-	-	-	-	-	-	335	456	425	442	-	-	RT5D		630	630	
-	-	250	475	280	480	355	485	450	462	-	-	RT5E		630	630	
150	500	-	-	300	508	375	513	-	-	-	-	RT5E		630	630	
160	520	280	530	315	530	400	543	-	-	-	-	RT5E	630	630		
-	-	-	-	-	-	-	-	-	-	375	256	CK12	RT5B	315	355	
-	-	-	-	-	-	-	-	-	-	400	273		RT5C	400	425	
-	-	-	-	-	-	-	-	-	-	425	290		RT5C	400	425	
-	-	-	-	-	-	-	-	-	-	450	307		RT5C	400	425	
-	-	-	-	-	-	-	-	475	488	-	-		RT5E	630	630	
-	-	-	-	-	-	-	-	500	514	-	-		RT5E	630	630	
-	-	300	563	335	565	-	-	-	-	-	-		RT5E	630	630	
185	609	315	580	355	600	-	-	-	-	-	-		RT5E	630	630	
200	630	335	630	375	630	450	613	-	-	-	-		RT5E	800	800	
220	710	355	650	-	-	475	647	-	-	-	-		RT5E	800	800	
-	-	375	680	400	673	-	-	-	-	-	-	RT5E	800	800		
-	-	-	-	-	-	-	-	-	-	475	324	CK13	RT5C	500	630	
-	-	-	-	-	-	-	-	-	-	500	341		RT5C	500	630	
-	-	-	-	-	-	500	680	-	-	-	-		RT6A	1000	1000	
-	-	400	720	425	714	-	-	-	-	-	-		RT6A	1000	1000	
-	-	425	763	450	756	-	-	-	-	-	-		RT6A	1000	1000	
250	823	450	800	-	-	-	-	-	-	-	-		RT6A	1000	1000	

Intro

A

B

C

D

E

F

G

H

I

X



Star-delta starters

For AC squirrel cage motors

In order to use this type of starting, the following conditions must be met:

The ends of the three stator windings should terminate in a terminal box (6 terminals, see diagram).

The line voltage should be the same as the motor delta connection voltage.

This starting system is suitable for machines where the resisting torque during starting is less than $1/3$ of the motor torque (see torque speed curves).

The target of this type of starting is to reduce the current during starting to $1/3$, thereby reducing the linedrop (see current speed curves).

Reduce the motor torque to $1/3$ to smooth out mechanical stress on the machine and on the load (see torque speed curves).

Torque-speed curve

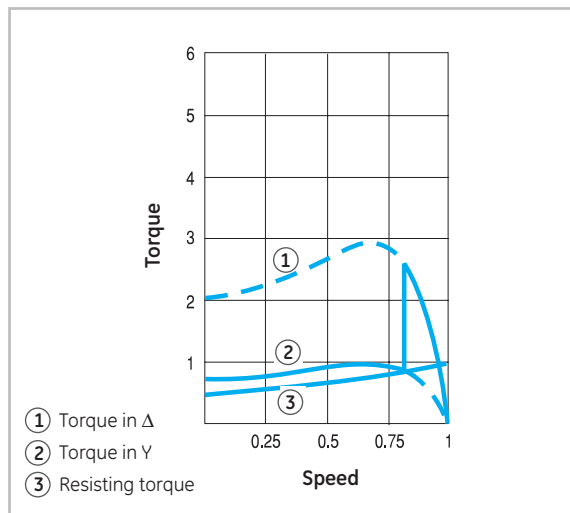

Current-speed curve

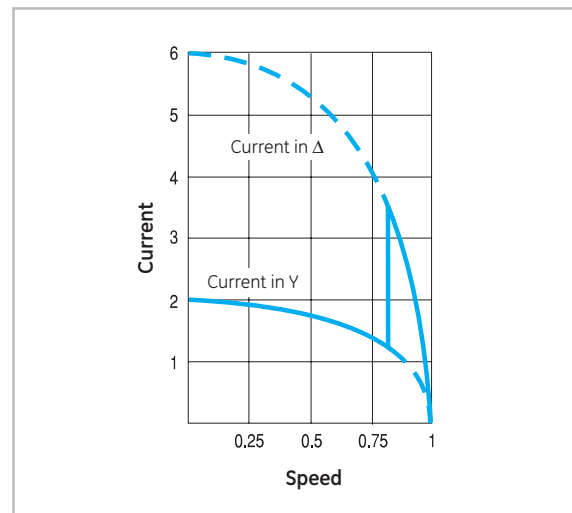

Power circuit

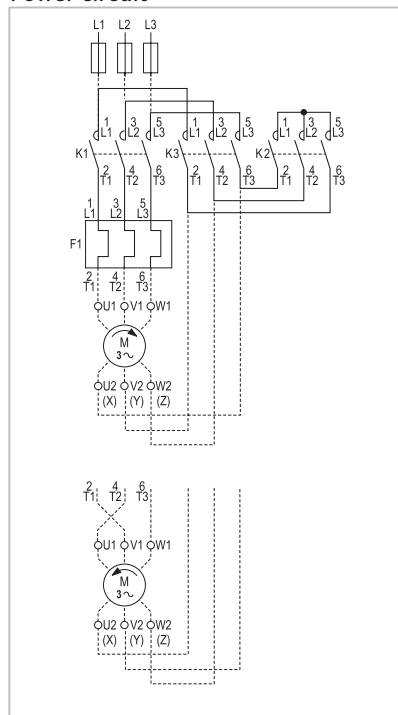

Control circuit

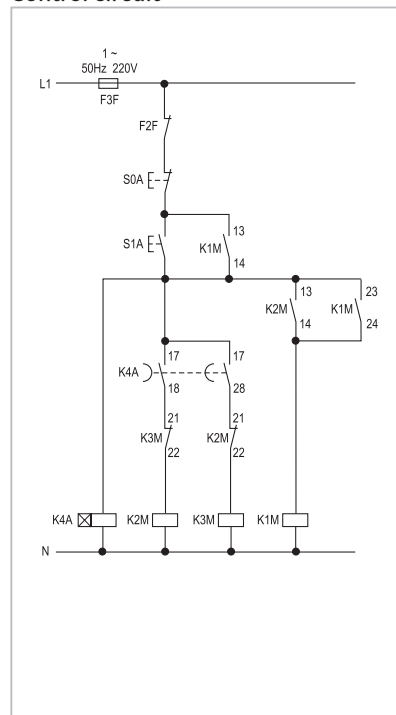

Star-delta starters

Selection table

		Motor						Contactors		Thermal	Fuse							
		230/200V		400/380V		440/415V		500V		690/660V		1000V		Line and	Star	relay	aM	gG-gL
		kW	A	kW	A	kW	A	kW	A	kW	A	kW	A	Delta			A	A
		2.2	9	4	9	-	-	5.5	9	7.5	9	-	-	EC09	EC09	ECRT1B10L	16	25
		3	12	5.5	12	5.5	11	7.5	12	-	-	-	-	EC09	EC09	ECRT1B10M	16	35
		3.7	14	-	-	-	-	-	-	-	-	-	-	EC09	EC09	ECRT1B10N	20	40
		4	16	7.5	16	7.5	14	-	-	-	-	-	-	EC12	EC09	ECRT1B10N	20	40
		-	-	-	-	-	-	-	-	11	13	-	-	EC12	EC09	ECRT1B10M	20	40
		-	-	-	-	-	-	11	17	-	-	-	-	EC12	EC09	ECRT1B10N	20	40
		5.5	21	11	22.5	11	21	-	-	-	-	-	-	EC18	EC12	ECRT1B10P	32	50
		-	-	-	-	-	-	-	-	15	18	-	-	EC18	EC12	ECRT1B10P	32	50
		-	-	-	-	-	-	15	23	-	-	-	-	EC18	EC12	ECRT1B10P	32	50
		-	-	-	-	-	-	-	-	18.5	23	-	-	EC25	EC18	ECRT1B10P	32	50
		7.5	27	15	30	15	28	-	-	-	-	-	-	EC25	EC18	ECRT1B10S	40	63
		-	-	-	-	-	-	18.5	28.5	22	26	-	-	EC25	EC18	ECRT1B10S	40	63
		-	-	-	-	18.5	35	22	33	-	-	-	-	EC25	EC18	ECRT1B10T	50	80
		11	40	18.5	37	-	-	-	-	-	-	-	-	EC25	EC25	ECRT2B10U	50	63
		-	-	-	-	-	-	-	-	30	35	-	-	EC25	EC25	ECRT2B10T	50	63
		-	-	22	44	22	40	30	45	-	-	-	-	EC25	EC25	ECRT2B10U	63	80
		15	50	25	50	-	-	-	-	-	-	-	-	EC32	EC25	ECRT2B10V	63	80
		-	-	-	-	-	-	-	-	37	41	-	-	EC40	EC25	ECRT2B10U	50	80
		-	-	30	60	30	55	-	-	-	-	-	-	EC40	EC25	ECRT2B10W	63	80
		18.5	65	-	-	-	-	-	-	-	-	-	-	EC40	EC25	ECRT2B10W	80	125
		-	-	-	-	-	-	37	55	45	49	-	-	EC40	EC25	ECRT2B10V	63	80
		22	75	-	-	-	-	-	-	-	-	-	-	EF50	EC32	RT2G	100	160
		-	-	33	65	37	66	-	-	-	-	-	-	EF50	EC32	RT1W	80	100
		-	-	-	-	-	-	45	65	55	60	-	-	EF50	EC32	RT2E	100	160
		-	-	37	72	-	-	-	-	-	-	-	-	EF50	EC32	RT2E	100	160
		-	-	45	85	45	80	55	80	-	-	-	-	EF50	EC32	RT2G	100	160
		-	-	-	-	-	-	-	-	75	80	-	-	EF65	EF50	RT2G	100	160
		30	105	55	105	55	100	-	-	-	-	-	-	EF65	EF50	RT2H	125	160
		-	-	-	-	-	-	75	105	-	-	-	-	EF80	EF50	RT2H	125	160
		37	126	-	-	-	-	-	-	-	-	-	-	EF80	EF50	RT2J	160	200
		-	-	-	-	75	135	-	-	-	-	-	-	EF80	EF50	RT2J	160	200
		-	-	-	-	-	-	-	-	90	97	-	-	EF95	EF50	RT2H	125	160
		40	138	-	-	-	-	-	-	-	-	-	-	EF95	EF65	RT2L	160	250
		-	-	-	-	-	-	90	129	-	-	-	-	EF95	EF65	RT2J	160	250
		-	-	75	138	-	-	-	-	-	-	-	-	EF95	EF65	RT2L	160	250
		-	-	-	-	-	-	-	-	110	118	-	-	EF105	EF65	RT2J	160	250
		45	150	-	-	-	-	-	-	-	-	-	-	EF105	EF65	RT2L	160	250
		-	-	-	-	-	-	110	156	-	-	-	-	EF105	EF80	RT2L	200	250
		-	-	90	170	90	165	-	-	-	-	-	-	EF105	EF80	RT2M	200	250
		-	-	-	-	-	-	-	-	132	141	-	-	CK75C	EF80	RT3C	160	200
		55	182	-	-	-	-	132	188	-	-	-	-	CK75C	EF80	RT3D	200	250
		-	-	-	-	110	200	-	-	-	-	-	-	CK75C	EF80	RT3D	250	315
		-	-	-	-	-	-	-	-	150	166	-	-	CK75C	EF95	RT3D	200	250
		-	-	-	-	-	-	-	-	160	170	-	-	CK75C	EF105	RT3D	200	250
		-	-	110	211	-	-	150	218	-	-	-	-	CK75C	EF105	RT3E	250	315
		-	-	-	-	132	240	160	228	-	-	-	-	CK75C	EF105	RT3E	250	315
		75	239	-	-	-	-	-	-	-	-	-	-	CK75C	EF105	RT3E	250	315
		-	-	-	-	-	-	-	-	-	-	90	64	CK75C	CK75C	RT4LJ	80	125
		-	-	-	-	-	-	-	-	-	-	110	78	CK75C	CK75C	RT4LJ	108	160
		-	-	132	245	-	-	-	-	-	-	-	-	CK75C	EF105	RT3F	315	355
		-	-	-	-	-	-	-	-	185	193	-	-	CK75C	CK75C	RT3E	250	315
		-	-	150	288	150	269	185	261	-	-	-	-	CK08C	CK75C	RT3F	315	355
		-	-	-	-	160	285	-	-	-	-	-	-	CK08C	CK75C	RT3F	315	355
		-	-	-	-	-	-	-	-	200	207	-	-	CK08C	CK75C	RT3E	250	315
		-	-	-	-	-	-	-	-	220	230	-	-	CK08C	CK75C	RT3E	250	315
		90	309	-	-	-	-	-	-	-	-	-	-	CK08C	CK75C	RT3F	315	355

For electrical endurance see technical data in Chapter A, but first divide the rated power and current values shown in the table by 1.73. The thermal overload relay should be set at 0.58 In of the motor.

Star-delta starters

Intro

A

B

C

D

E

F

G

H

I

X



Selection table (continued 1)

Motor										Contactors		Thermal	Fuse			
230/200V		400/380V		440/415V		500V		690/660V		1000V		Line and Star	relay	aM	gG-gL	
kW	A	kW	A	kW	A	kW	A	kW	A	kW	A	Delta	Star	A	A	
-	-	-	-	-	-	-	-	-	-	132	94	CK08C	CK75C	RT4LK	125	160
-	-	-	-	-	-	-	-	-	-	150	105	CK08C	CK75C	RT3B	125	160
-	-	-	-	-	-	-	-	-	-	160	113	CK08C	CK75C	RT3B	125	160
-	-	-	-	-	-	-	-	-	-	185	130	CK85B	CK75C	RT4LL	160	200
-	-	160	309	-	-	200	281	250	262	-	-	CK85B	CK75C	RT4N	355	400
-	-	-	-	-	-	220	310	-	-	-	-	CK85B	CK75C	RT4N	355	400
-	-	-	-	185	325	-	-	-	-	-	-	CK85B	CK75C	RT4P	400	425
110	356	185	355	200	350	-	-	-	-	-	-	CK85B	CK75C	RT4P	400	425
-	-	-	-	-	-	-	-	280	262	-	-	CK09B	CK75C	RT4N	315	355
132	425	200	370	220	385	250	348	-	-	-	-	CK09B	CK75C	RT4P	500	500
-	-	220	408	-	-	280	385	-	-	-	-	CK09B	CK08C	RT4P	500	500
-	-	-	-	-	-	-	-	-	-	200	141	CK09B	CK08C	RT4LL	200	250
-	-	-	-	-	-	-	-	-	-	220	155	CK09B	CK08C	RT4LM	200	250
-	-	-	-	-	-	-	-	-	-	250	175	CK09B	CK08C	RT4LM	200	250
-	-	-	-	-	-	-	-	300	307	-	-	CK09B	CK08C	RT4N	355	400
-	-	-	-	-	-	-	-	315	322	-	-	CK09B	CK08C	RT4N	355	400
-	-	-	-	-	-	-	-	335	349	-	-	CK09B	CK08C	RT4P	500	500
-	-	-	-	-	-	-	-	-	-	280	197	CK95B	CK09B	RT4LM	250	315
-	-	-	-	250	437	-	-	-	-	-	-	CK95B	CK08C	RT4P	500	500
-	-	-	-	-	-	-	-	355	366	-	-	CK95B	CK85B	RT4P	425	500
-	-	-	-	-	-	300	409	375	390	-	-	CK95B	CK85B	RT4P	500	500
-	-	-	-	-	-	315	426	-	-	-	-	CK95B	CK85B	RT4P	500	500
150	500	250	475	280	480	-	-	-	-	-	-	CK95B	CK85B	RT4R	630	630
-	-	-	-	-	-	-	-	-	-	300	211	CK95B	CK85B	RT4LM	250	315
-	-	-	-	-	-	-	-	-	-	315	221	CK95B	CK85B	RT4LM	250	315
-	-	-	-	-	-	-	-	400	412	-	-	CK95B	CK85B	RT4R	500	500
-	-	-	-	-	-	-	-	425	442	-	-	CK95B	CK85B	RT4R	500	500
-	-	-	-	300	508	335	456	450	462	-	-	CK10C	CK85B	RT5C	630	630
160	520	-	-	-	-	355	485	-	-	-	-	CK10C	CK85B	RT4C	630	630
-	-	-	-	-	-	375	513	-	-	-	-	CK10C	CK85B	RT5C	630	630
-	-	280	530	315	530	-	-	-	-	-	-	CK10C	CK85B	RT5C	630	630
-	-	300	563	355	561	-	-	-	-	-	-	CK10C	CK85B	RT5C	630	630
-	-	315	580	-	-	-	-	-	-	-	-	CK10C	CK85B	RT5C	630	630
185	609	-	-	355	600	-	-	-	-	-	-	CK10C	CK85B	RT5C	800	800
-	-	-	-	-	-	-	-	-	-	335	234	CK10C	CK09B	RT5A	315	355
-	-	-	-	-	-	-	-	-	-	355	245	CK10C	CK09B	RT5A	315	355
-	-	-	-	-	-	-	-	-	-	375	256	CK10C	CK09B	RT5A	315	355
-	-	-	-	-	-	-	-	-	-	400	273	CK10C	CK09B	RT5A	355	400
-	-	-	-	-	-	-	-	-	-	425	290	CK10C	CK09B	RT5A	355	400
-	-	-	-	-	-	-	-	-	-	450	307	CK10C	CK09B	RT5A	355	400
-	-	-	-	-	-	-	-	475	488	-	-	CK10C	CK09B	RT5C	630	630
-	-	-	-	-	-	-	-	500	514	-	-	CK10C	CK09B	RT5C	630	630
-	-	-	-	-	-	400	543	530	545	-	-	CK10C	CK09B	RT5C	630	630
-	-	-	-	375	587	425	580	560	575	-	-	CK10C	CK09B	RT5C	630	630
200	630	335	630	375	630	450	613	-	-	-	-	CK10C	CK09B	RT5D	800	800
-	-	355	650	-	-	-	-	-	-	-	-	CK10C	CK09B	RT5D	800	800
-	-	-	-	-	-	-	-	600	616	-	-	CK10C	CK95B	RT5D	800	800
-	-	-	-	400	622	475	647	630	646	-	-	CK10C	CK95B	RT5D	800	800
-	-	-	-	-	-	-	-	-	-	475	324	CK10C	CK95B	RT5B	355	400
-	-	-	-	-	-	-	-	-	-	500	341	CK10C	CK95B	RT5B	400	425
-	-	-	-	-	-	-	-	-	-	600	407	CK10C	CK95B	RT5B	500	500
-	-	-	-	400	673	425	659	-	-	-	-	CK10C	CK10C	RT5D	800	800
-	-	375	680	-	-	500	680	670	688	-	-	CK11C	CK10C	RT5D	800	800
220	710	400	720	425	714	530	725	710	729	-	-	CK11C	CK10C	RT5D	800	800
-	-	-	-	450	756	560	762	750	770	-	-	CK11C	CK10C	RT5E	1000	1000
-	-	425	763	475	798	-	-	-	-	-	-	CK11C	CK10C	RT5E	1000	1000
-	-	-	-	-	-	600	817	-	-	-	-	CK11C	CK10C	RT5E	1000	1000

For electrical endurance see technical data in Chapter A, but first divide the rated power and current values shown in the table by 1.73. The thermal overload relay should be set at 0.58 In of the motor.

Star-delta starters

Intro

A

B

C

D

E

F

G

H

I

X



Star-delta starters

Selection table (continued 2)

		Motor										Contactors		Thermal	Fuse			
		230/200V		400/380V		440/415V		500V		690/660V		1000V		Line and Delta	Star	relay	aM	gG-gL
		kW	A	kW	A	kW	A	kW	A	kW	A	kW	A				A	A
		250	823	-	-	-	-	-	-	-	-	-	-	CK11C	CK10C	RT5E	1000	1000
		-	-	-	-	-	-	-	-	-	-	630	428	CK11C	CK10C	RT5B	500	630
		-	-	-	-	-	-	-	-	-	-	670	455	CK11C	CK10C	RT5C	500	630
		-	-	450	800	-	-	-	-	-	-	-	-	CK11C	CK10C	RT5E	1000	1000
		-	-	475	846	500	840	-	-	-	-	-	-	CK11C	CK10C	RT5E	1000	1000
		-	-	-	-	-	-	-	-	800	821	-	-	CK11C	CK10C	RT5E	1000	1000
		-	-	500	892	530	890	630	857	850	873	-	-	CK11C	CK10C	RT5E	1000	1000
		280	910	530	943	560	941	670	912	-	-	-	-	CK11C	CK10C	RT5E	2×630	2×630
		300	975	-	-	-	-	710	965	-	-	-	-	CK12B	CK10C	RT5E	2×630	2×630
		315	1023	560	996	600	1010	750	1020	-	-	-	-	CK12B	CK10C	RT5E	2×630	2×630
		335	1083	-	-	630	1058	-	-	-	-	-	-	CK12B	CK10C	RT5E	2×630	2×630
		-	-	-	-	-	-	-	-	-	-	750	510	CK12B	CK11C	RT5C	630	630
		-	-	-	-	-	-	-	-	900	924	-	-	CK13B	CK11C	RT6A	2×630	2×630
		-	-	-	-	-	-	800	1088	950	975	-	-	CK13B	CK11C	RT6A	2×630	2×630
		-	-	600	1074	-	-	-	-	-	-	-	-	CK12B	CK11C	RT5E	2×630	2×630
		355	1142	-	-	710	1097	-	-	-	-	-	-	CK12B	CK11C	RT5E	2×630	2×630
		-	-	-	-	-	-	-	-	-	-	800	543	CK13B	CK11C	RT5C	630	800
		-	-	630	1128	670	1125	-	-	-	-	-	-	CK12B	CK11C	RT5E	2×630	2×630
		375	1206	670	1200	710	1190	850	1156	-	-	-	-	CK13B	CK11C	RT6A	2×800	2×800
		400	1286	710	1270	750	1255	-	-	-	-	-	-	CK13B	CK11C	RT6A	2×800	2×800
		425	1364	-	-	-	-	-	-	-	-	-	-	CK13B	CK12B	RT6A	2×800	2×800
		-	-	750	1342	-	-	-	-	-	-	-	-	CK13B	CK12B	RT6A	2×800	2×800

For electrical endurance see technical data in Chapter A, but first divide the rated power and current values shown in the table by 1.73. The thermal overload relay should be set at 0.58 In of the motor.

Star-delta starters

Intro

A

B

C

D

E

F

G

H

I

X



Contactors for connection of power transformers

In this application it is essential to ascertain the no-load inrush current of the transformer I_{μ} , (magnetisation current) which in the majority of cases determines the size of the contactor.

Two cases are illustrated in the table:

- No-load inrush current up to 20 times the rated transformer current
- No-load inrush current up to 40 times the rated transformer current.

The contactor should not cut out the short-circuit current; if the protective devices used are fuses, this condition will be intrinsically complied with.

In the case however of devices with tripping contacts the general line circuit breaker will be driven rather than the contactor coil.

Selection table

$\frac{I_{\mu}}{I_e} = 20$		$\frac{I_{\mu}}{I_e} = 40$		Contactor
230V 240V kVA	380V 400V kVA	230V 240V kVA	380V 400V kVA	
2	3.5	1	1.75	EC09
2.75	5	1.37	2.5	EC12
4	7	2	3.5	EC18
5.75	10	2.85	5	EC25
7.25	12.5	3.65	6.25	EC32
9	15.5	4.50	7.75	EC40
12	21	6	10.5	EF50
15	25	7.5	12.5	EF65
20	35	10	16	EF80
25	40	12.5	20	EF95
30	50	15	25	EF95
35	55	17	27	CK75C
40	60	20	30	CK08C
45	75	22	35	CK85B
50	85	25	42.5	CK09B
80	150	40	75	CK10C
100	170	50	85	CK11C
127	215	64	107	CK12B
160	280	80	140	CK13B

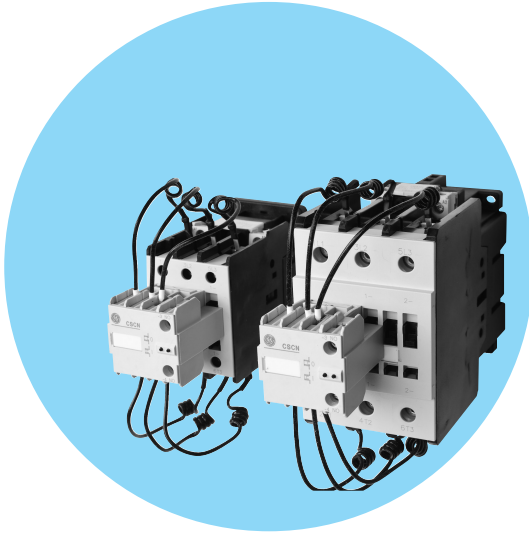

Standards

IEC/EN 60947-1	CENELEC HD 419
IEC/EN 60947-4-1	VDE 0660/102
IEC/EN 60947-5-1	NFC 63-110
EN 50005	ASE 1025
UL 508	UNE 20109
CSA C22.2/14	

Approvals/Marking



Contactors for capacitors switching

With built-in resistance to switch three phase capacitor banks

“CSCN” contactors incorporate a front block with three early-make auxiliary contacts together with 6 quick precharge resistors (two per phase) through which the capacitors are switched to the network, reducing the current peak. Once the resistors have damped the current peak, the main contacts short-circuit the resistors, carrying the uninterrupted current. A few milliseconds later the early-make auxiliary contact closes to guarantee that all current flows through the main contacts.

Standard voltages

To complete the catalogue number, replace the symbol \blacklozenge by the code corresponding to the voltage and frequency of the control circuit, other voltages on request.

AC Coils (V)

	-	1	2	9	J	K	L	6	7	N	U	Y
50/60Hz		24	42	48	110			220-230	240			
50 Hz						127					380-400	500
60Hz					120		208			277	480	600

Operating voltage limits with bifrequency coils:

With 60Hz = 0.85 to 1.1 × Us

With 50Hz = 0.8 to 1.1 × Us in continuous service (ED = 100%) with a maximum ambient temperature of 40°C

Technical data

Technical characteristics

			CSCN12	CSCN16	CSCN20	CSCN25	CSCN30	CSCN45	CSCN55	CSCN70
Main circuit (poles)										
Rated operational voltage	(V)		690	690	690	690	690	690	690	690
Rated insulation voltage according to IEC947	(V)		1000	1000	1000	1000	1000	1000	1000	1000
Rated thermal current	(A)		25	32	45	45	60	90	110	140
Max. power utilization at 55°C	230/240V	(kvar)	7.5	10	12.5	15	20	25	35	45
	380/400V	(kvar)	12.5	16.7	20	25	30	45	55	70
	660/690V	(kvar)	15	20	25	30	35	55	65	85
Electrical endurance	(ops.)		280.000	280.000	280.000	250.000	200.000	150.000	120.000	90.000
Max. ops./hour	(ops./hour)		350	350	350	240	240	150	150	150
Control circuit										
Standard voltages	50Hz	(V)	24-690	24-690	24-690	24-690	24-690	24-690	24-690	24-690
	60Hz	(V)	24-600	24-600	24-600	24-600	24-600	24-600	24-600	24-600
Consumption										
Single frequency	Mar. circuit open	(VA)	45	45	48	48	88	191	191	198
	Mar. circuit closed	(VA)	6	6	7	7	9	15.5	15.5	17
Dual frequency	Mar. circuit open	(VA)	54	54	58	58	125	245	245	250
	Mar. circuit closed	(VA)	7	7	8	8	11.5	20	20	23
50Hz	Mar. circuit open	(VA)	35	35	39	39	110	215	215	220
	Mar. circuit closed	(VA)	5	5	6	6	11	15	15	19
60Hz	Mar. circuit open	(VA)								
	Mar. circuit closed	(VA)								

Instantaneous auxiliary contact blocks

Rated insulation voltage Ui	(V)									1000
Rated thermal current Ith	(A)									10

Ambient conditions

Storage temperature	(°C)									-50 ... +80
Operating temperature	(°C)									-25 to +55 (without derating)
Altitude up to 3000m										Nominal values
Mounting positions										Vertical mounting ±30°

Terminal capacity and tightening torque

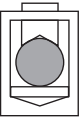
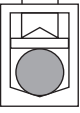
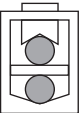
			CSCN12	CSCN16	CSCN20	CSCN25	CSCN30	CSCN45	CSCN55	CSCN70
	Solid, stranded and finely stranded without end sleeve	(mm ²)	1 x 0.5 ... 2.5		1 x 0.5 ... 2.5		-	-	-	-
	Finely stranded with or without end sleeve	(mm ²)	1 x 1 ... 2.5		1 x 1 ... 2.5		-	-	-	-
	AWG wires		1 x 20 ... 12		1 x 20 ... 8		-	-	-	-
	Tightening torque	(Nm)	1.6		2.2		-	-	-	-
		(Lb x in.)	15		20		-	-	-	-
	Solid, stranded and finely stranded without end sleeve	(mm ²)	-		-		0.75 ... 16	1 ... 35		1.5 ... 50
	Finely stranded with end sleeve	(mm ²)	-		-		0.75 ... 16	1 ... 35		1.5 ... 50
	Finely stranded without end sleeve	(mm ²)	-		-		1 ... 16	1 ... 35		1.5 ... 50
	AWG wires		-		-		18 ... 6	16 ... 2		16 ... 2
	Tightening torque	(Nm)	-		-		1.8	4		5.6
	(Lb x in.)	-		-		16	35		50	
	Solid	(mm ²)	-		-		0.75 ... 16	1 ... 16		4 ... 35
	Stranded	(mm ²)	-		-		0.75 ... 16	1 ... 25		4 ... 35
	Finely stranded without end sleeve	(mm ²)	-		-		0.75 ... 16	1 ... 25		4 ... 35
	Finely stranded with end sleeve	(mm ²)	-		-		1 ... 16	1 ... 25		4 ... 35
	AWG wires		-		-		18 ... 6	16 ... 4		10 ... 1
Tightening torque	(Nm)	-		-		1.8	4		5.6	
	(Lb x in.)	-		-		16	35		50	
	Solid, stranded and finely stranded without end sleeve	(mm ²)	-		-		Max. 16	Max. 50 ... 4		Max.
	Finely stranded without end sleeve	(mm ²)	-		-		Max. 16	Max. 25 ... 16		50 ... 35
	Finely stranded with end sleeve	(mm ²)	-		-		Max. 16	Max. 35 ... 2.5		Max. 35
	AWG wires		-		-		Max. 6	Max. 25 ... 16		Max. 1
	Tightening torque	(Nm)	-		-		1.8	4		5.6
	(Lb x in.)	-		-		16	35		50	

Coil Terminal capacity and tightening torque

Tightening torque		0.8Nm - 7Lb/in
Solid Wire	(mm ²)	0.75 to 2x2
Flexible wire without terminal	(mm ²)	0.75 to 2.5x2
Flexible wire without terminal with cap	(mm ²)	0.75 to 2.5x21

Dimensional drawings

Contactors for capacitors switching

CSCN12..., CSCN16...

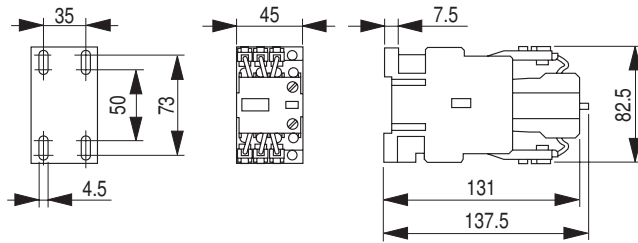

CSCN20..., CSCN25...

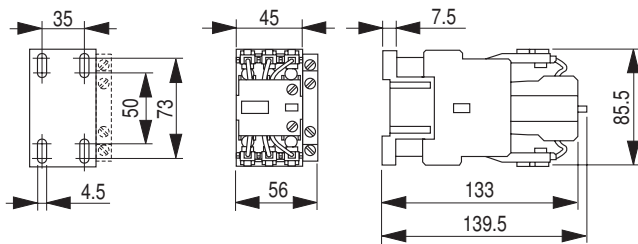

CSCN30...

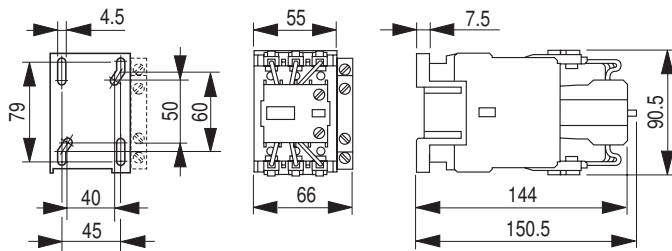

CSCN45..., CSCN55...

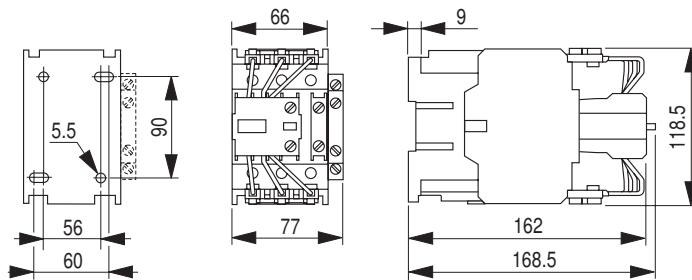

CSCN70...

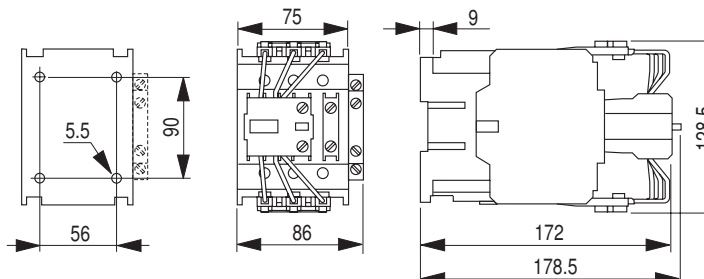

Standard contactors for capacitors (category AC6b)

The most usual application of capacitors is for centralised automatic power factor ($\cos \phi$) correction. A characteristic of capacitors is the high overcurrent which appears as they are connected.

Such overcurrents are due to:

- Harmonic currents produced by saturated transformers, rectifiers, etc.
- Transient currents, the frequency and amplitude of which depend on the network inductance and the capacitor size.
- Additional transient currents arising where a capacitor is connected when others have already been connected, and caused by discharging of the latter.

GE Power Controls contactors are fitted with specially treated hardened alloy contacts which are highly resistant to welding and are therefore capable of withstanding high current peaks on connection.

The operation conditions taken as a basis for usage are:

- Near presence of other previously connected capacitors with a total power of up to eight times that of the capacitor to be connected.
- Shock coils reactances with a minimum inductance of $4\mu\text{H}$. These can be obtained by making 4 or 6 turns of 15cm windings on the conductor of each phase.
- Fast discharge resistor for reconnection within 60 seconds.

Diagram

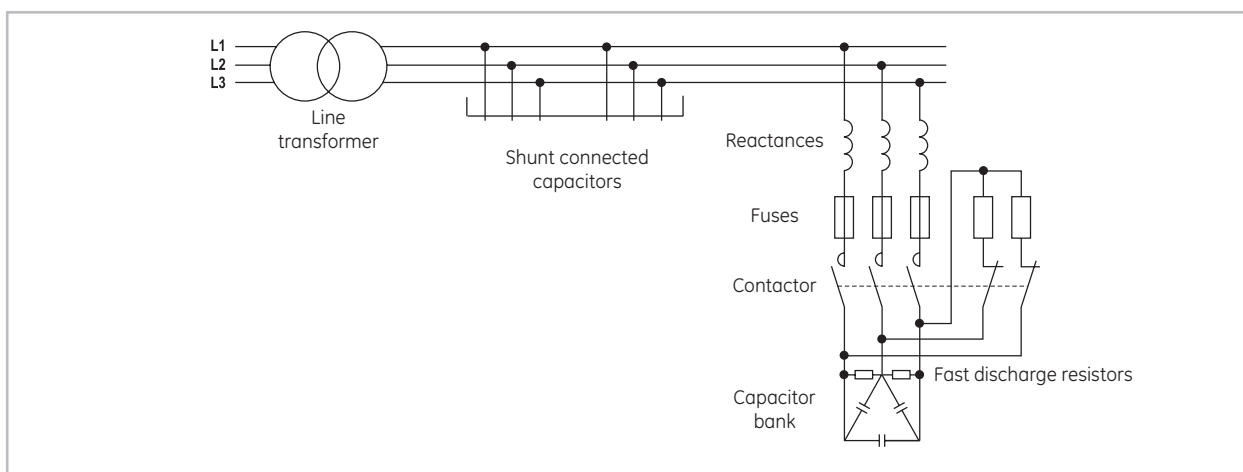

Selection table

Contactor		$\theta \leq 55^\circ\text{C}$					$\theta \leq 70^\circ\text{C}$					Fuse gl - gG	I max. (peak)
Type	I _{th}	220V 230V 240V	400V	415V	500V	690V 660V	220V 230V 240V	400V	415V	500V	690V 660V		
	A	kvar	kvar	kvar	kvar	kvar	kvar	kvar	kvar	kvar	kvar	A	A
CL00A	25	3	5	5.5	6.5	5.7	2.4	4	4.5	5.2	4.5	10	1000
CL01A	25	4.5	9.5	10.5	12.5	11	3.6	6	6.5	10	7	16	1000
CL02A	32	6.5	11	12	14.5	12.5	5.2	8.5	9	11.5	10	25	1000
CL03A3	45	7.5	12.5	14	16	15	6.5	10	11	13	12	25	1000
CL04A	60	12.5	21	23	27.5	24	10	17	18	22	19.5	40	2500
CL05A	60	16.5	25	27	32	30	13	20	22	25	22	50	2500
CL06A	90	22	40	43	52	50	17	30	33	41	35	80	3500
CL07A	110	25	45	48	58	65	19	35	37	46	40	125	3500
CL08A	110	30	50	54	65	70	22	40	43	52	50	125	3500
CL09A	140	40	65	70	85	95	35	58	62	75	85	160	3500
CL10A	140	45	70	80	90	105	43	70	75	90	105	160	3500
CK75C	250	60	110	118	145	150	48	88	94	116	120	250	5000
CK08C	250	70	125	135	162	170	56	100	107	130	136	250	5000
CK85B	315	80	150	160	195	200	64	120	130	156	160	315	5000
CK09B	315	95	165	177	215	230	85	148	160	192	205	315	5000
CK95B	450	105	190	205	250	288	95	175	188	230	265	450	5500
CK10C	600	135	260	280	340	370	120	235	252	375	330	630	10000
CK11C	700	190	325	350	425	450	152	260	280	340	360	800	10000
CK12B	1000	250	400	430	520	600	200	320	344	416	480	1000	12000
CK13B	1250	315	525	565	685	650	252	420	452	548	520	1250	15000

Electrical endurance: 100.000 operations

Everything is under control

Contactors for control lighting circuits

The characteristics of the most usual lighting systems are as follows:

Incandescent lamps

The connection current in very high -of the order of 15 times- rated current. Although this is a very short duration, it is only taken into account in order for the contactor connection current not to be exceeded. The power factor is always maintained at 1.

Fluorescent lamps

The connection current is slightly higher than rated current. The power factor is about 0.5. To improve up to 0.9, compensating capacitors can be used. In such cases, the connection power of the capacitor must be taken into account, the effect of which is appreciably greater on the smaller contactors.

High pressure mercury vapour lamps

The connection current varies, depending on type, between 1.6 and 2 times the rated current and will hold for between 3 and 5 minutes.

The power factor is of the order of 0.6 and this can be improved up to approximately unit value by means of compensating capacitors. In such cases, the connection power of the capacitor must be taken into account, the effect of which is appreciably greater on the smaller contactors.

High pressure sodium vapour lamps

The connection current values varies, depending on type, between 1.3 and 1.6 times the rated current and will hold between 3 and 5 minutes.

The power factor is of the order of 0.45 and this can be improved up to approximately unit value by means of compensating capacitors. In such cases, the connection power of the capacitor must be taken into account, the effect of which is appreciably greater on the smaller contactors.

Selection table

Types	W	A	µF	MCR	MCO	MC1	MC2	RL	CL00	CL01	CL02	CL03*3	
Incandescent	60	0.27		27	37	59	59	59	62	62	70	77	
	100	0.45		16	22	35	35	35	40	40	50	60	
	200	0.91		Poles No.		11	17	17	17	20	20	25	30
	300	1.36		5	7	11	11	11	13	13	17	20	
	500	2.27		3	4	7	7	7	8	8	10	12	
	1000	4.5		1	2	3	3	3	4	4	5	6	
	2000	9.1		0	1	1	1	1	1	1	2	3	
Fluorescent Single arrangement Without compensation	15	0.23		51	61	79	79	79	88	98	126	155	
	20	0.37		32	38	49	49	49	57	61	78	110	
	40	0.44		28	33	41	41	41	48	51	66	93	
	65	0.7		18	21	26	26	26	30	32	41	58	
100	1.5		8	10	12	12	12	14	16	19	27		
Fluorescent Single arrangement With compensation	15	0.23	3.5	26	32	49	49	49	61	77	94	111	
	20	0.25	4.5	20	25	38	38	38	48	61	74	87	
	40	0.3	4.5	20	25	38	38	38	48	61	74	87	
	65	0.45	7	13	14	25	25	25	31	39	47	56	
100	0.7	18	5	6	9	9	9	11	14	17	21		
High pressure mercury vapour Without compensation	250	2.13		5	5	5	6	6	6	8	10	12	
	400	3.25		3	3	4	4	4	4	5	6	8	
	700	5.4		2	2	2	2	2	2	3	4	5	
1000	7.5		1	1	2	2	2	2	2	3	3		
High pressure mercury vapour With compensation	250	1.3	20	9	9	9	9	11	11	14	18	22	
	400	2.1	25	7	7	7	7	7	7	9	11	14	
	700	3.6	40	5	5	5	5	4	4	5	6	8	
	1000	5.3	60	3	3	3	3	3	3	3	4	5	
High pressure sodium vapour Without compensation	250	3		3	3	4	4	4	4	5	7	9	
	400	4.4		2	2	3	3	3	3	4	5	6	
	1000	10.3		1	1	1	1	1	1	2	2	2	
High pressure sodium vapour With compensation	250	1.45	40	5	5	5	5	10	10	12	16	20	
	400	2.5	45	4	4	4	4	6	6	7	9	11	
	1000	5.5	100	2	2	2	2	3	3	3	4	5	
	250	2.17	-	3	3	4	4	4	4	5	7	9	
Metal iodide Without compensation	400	3.48	-	2	2	2	3	3	3	3	4	6	
	700	6.09	-	1	1	1	1	1	1	2	2	3	
	1000	8.7	-	1	1	1	1	1	1	1	2	2	
	2000	17.39	-	0	0	0	1	1	1	1	1	1	
	250	1.4	32	0	6	6	7	7	7	9	11	16	
Metal iodide With compensation	400	2.0	45	0	4	5	5	5	5	6	8	11	
	700	3.6	65	0	2	3	3	3	3	3	4	6	
	1000	5.3	85	0	2	2	2	2	2	2	3	4	
	2000	10.6	100	0	0	0	0	0	1	1	2	2	

- Intro
- A
- B
- C
- D**
- E
- F
- G
- H
- I
- X



Diagrams

Single-phase circuit

The total number of lamps will be as shown in the table.

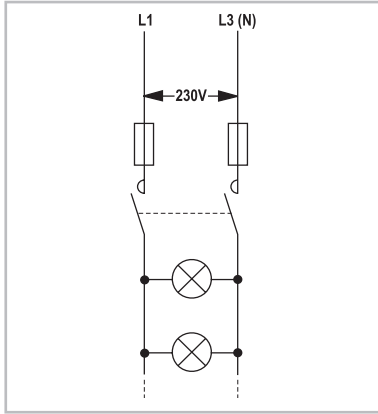

3-phase circuit, lamps delta-connected

The total number of lamps will be as shown in the table, multiplied by 1.73 and distributed in three equal quantities.

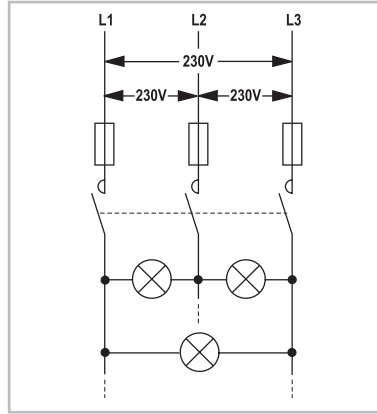

3-phase circuit, lamps star-connected

The total number of lamps will be as shown in the table, multiplied by 3 and distributed in three equal quantities.

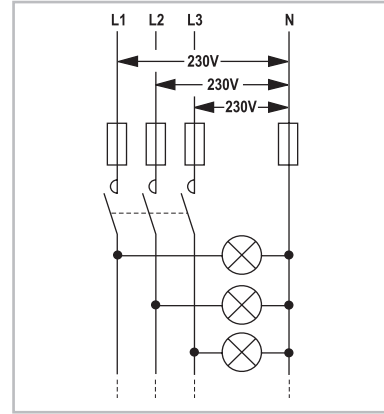

Maximum number of lamps per phase at 230V

CL03*4	CL04	CL05	CL06	CL07	CL08	CL09	CL10	CK75C	CK08C	CK09	CK95	CK10	CK11	CK12	CK13
77	85	122	156	191	222	264	284	333	410	555	820	1320	1550	1860	1860
60	66	73	95	116	133	160	170	200	246	333	490	790	930	1120	1120
30	33	36	47	58	66	79	84	99	122	165	240	390	460	550	550
20	22	24	31	38	44	53	56	66	81	110	165	260	300	370	370
12	12	14	19	23	26	31	33	39	48	66	95	155	185	220	220
6	6	7	9	11	13	16	17	20	24	33	50	80	90	110	110
3	3	3	4	5	7	8	8	10	12	16	25	40	45	55	55
177	224	237	355	390	434	496	553	790	988	1245	1770	2340	2740	3910	4890
125	139	147	221	243	270	309	344	490	614	774	1090	1460	1700	2430	3040
105	118	124	186	204	227	260	289	413	516	650	920	1220	1430	2045	2550
66	74	78	116	127	142	163	181	259	324	409	570	770	900	1280	1600
30	34	36	54	59	66	76	85	121	151	190	270	360	420	600	750
119	134	149	191	232	273	312	347	496	621	786	900	1240	1450	1740	1740
92	103	115	148	180	212	243	270	385	482	610	700	960	1120	1350	1350
92	103	115	148	180	212	243	270	385	482	610	700	960	1120	1350	1350
59	66	74	95	115	136	155	173	248	310	393	440	610	720	860	860
23	23	29	37	45	53	60	67	96	120	152	170	240	280	330	330
14	15	18	27	30	33	36	42	60	75	95	136	181	211	302	377
9	10	12	18	20	22	24	28	40	49	62	89	119	138	198	247
5	6	7	11	12	13	14	17	24	30	38	54	71	83	119	149
4	4	5	8	9	9	10	12	17	21	27	39	51	60	86	107
31	27	33	49	55	60	66	77	109	156	156	171	311	311	374	467
25	17	20	31	34	37	41	48	87	125	125	137	249	249	299	374
16	10	12	18	20	22	24	28	54	78	78	86	156	156	187	234
10	7	8	12	13	15	16	19	36	52	52	57	104	104	125	156
10	11	13	19	21	24	26	30	43	54	68	96	129	150	214	268
7	7	9	13	15	16	18	20	29	37	46	66	88	102	146	183
3	3	4	6	6	7	7	9	12	16	20	28	37	44	62	78
16	25	30	44	49	54	59	69	57	81	81	90	163	163	195	244
14	14	17	26	29	31	34	40	51	72	72	80	145	145	174	217
7	6	8	12	13	14	16	18	23	33	33	36	65	65	78	98
12	12	12	19	21	23	25	29	41	52	65	93	124	145	207	259
8	8	8	12	13	14	16	18	26	32	41	58	78	91	129	162
4	4	4	7	7	8	9	10	15	18	23	33	44	52	74	92
3	3	3	5	5	6	6	7	10	13	16	23	31	36	52	65
2	2	2	2	3	3	3	4	5	6	8	12	16	18	26	32
21	21	21	32	36	39	43	50	68	97	97	107	195	195	234	292
15	15	15	23	25	28	30	35	48	69	69	76	138	138	166	208
8	8	8	13	14	15	17	19	34	48	48	53	96	96	115	144
6	6	6	8	9	10	11	13	26	37	37	40	73	73	88	110
3	3	3	4	5	5	6	7	22	31	31	34	62	62	75	93



Efficor & MC Contactor DC Application

Contactors for DC - Max. operational current Ie (A) - DC utilization categories

Category DC1. L/R ≤ 1ms

Ue	Poles in serie	MC0	MC1	MC2	EC09	EC12	EC18	EC25	EC32	EC40	EF50	EF65	EF80	EF95	EF105
24V	1	6	9	9	18	18	18	25	32	40	50	65	65	80	80
	2	8	12	12	25	25	32	45	60	60	90	110	110	140	140
	3	15	20	20	25	25	32	45	60	60	90	110	110	140	140
	4	15	20	20	-	25	32	45	60	-	-	110	-	140	-
48V	1	5	7.5	7.5	15	15	15	20	25	35	45	55	55	70	70
	2	8	12	12	25	25	32	45	60	60	90	110	110	140	140
	3	12	16	16	25	25	32	45	60	60	90	110	110	140	140
	4	15	20	20	-	25	32	45	60	-	-	110	-	140	-
60V	1	4	6	6	12	12	12	18	18	32	40	50	50	65	65
	2	6	9	9	25	25	32	45	60	60	90	110	110	140	140
	3	12	16	16	25	25	32	45	60	60	90	110	110	140	140
	4	15	20	20	-	25	32	45	60	-	-	110	-	140	-
125V	1	1.6	2.5	2.5	6	6	6	8	8	8	16	16	16	16	16
	2	4	6	6	18	18	18	25	45	45	80	90	90	110	110
	3	5	10	10	25	25	25	45	60	60	90	110	110	140	140
	4	5	10	10	-	25	32	45	60	-	-	110	-	140	-
220V	1	0.2	0.36	0.36	0.8	0.8	0.8	1	1	1	2	2	2	2	2
	2	1.7	2.6	2.6	7.5	7.5	7.5	8	8	8	20	20	20	20	20
	3	4	8	8	25	25	25	45	50	50	90	110	110	140	140
	4	4	8	8	-	25	32	45	60	-	-	110	-	140	-
440V	1	0.09	0.13	0.13	0.4	0.4	0.4	0.5	0.5	0.5	0.8	0.8	0.8	0.8	0.8
	2	0.26	0.4	0.4	0.8	0.8	0.8	1	1	1	2	2	2	2	2
	3	0.5	1	1	8	8	8	10	10	10	15	15	15	15	15
600V	4	0.5	1	1	-	15	15	20	25	-	-	90	-	110	-
	1	-	-	-	-	-	-	-	-	-	-	-	-	-	-
	2	-	-	-	0.4	0.4	0.4	0.5	0.5	0.5	1	1	1	1	1
	3	-	-	-	4	4	4	5	5	5	7.5	7.5	7.5	7.5	7.5
4	-	-	-	-	8	10	12	12	-	-	65	-	75	-	

Category DC3. L/R ≤ 2.5ms

Ue	Poles in serie	MC0	MC1	MC2	EC09	EC12	EC18	EC25	EC32	EC40	EF50	EF65	EF80	EF95	EF105
24V	1	-	-	-	12	12	12	18	25	32	40	50	50	65	65
	2	4	9	9	18	18	18	25	40	40	65	80	80	105	105
	3	8	12	12	18	18	18	25	40	40	65	80	80	105	105
	4	-	-	-	-	18	18	25	40	-	-	80	-	105	-
48V	1	-	-	-	9	9	9	12	18	20	30	35	35	45	45
	2	3	6	6	18	18	18	25	40	40	65	80	80	105	105
	3	6	9	9	18	18	18	25	40	40	65	80	80	105	105
	4	-	-	-	-	18	18	25	40	-	-	80	-	105	-
60V	1	-	-	-	7.5	7.5	7.5	10	15	15	25	30	30	35	35
	2	3	6	6	18	18	18	25	40	40	65	80	80	105	105
	3	6	9	9	18	18	18	25	40	40	65	80	80	105	105
	4	-	-	-	-	18	18	25	40	65	-	80	-	105	-
125V	1	-	-	-	2	2	2	3	3	3	3	3	3	3	3
	2	0.85	4.5	4.5	10	10	12	18	25	50	50	60	60	80	80
	3	1.7	6	6	15	15	18	25	32	35	35	80	80	105	105
	4	-	-	-	-	15	18	25	32	35	-	80	-	105	-
220V	1	-	-	-	0.6	0.6	0.6	0.6	0.6	0.8	0.8	0.8	0.8	0.8	0.8
	2	0.35	1.2	1.2	2	2	2	2	2	7	7	7	7	7	7
	3	0.7	2.5	2.5	12	12	12	18	25	50	50	65	65	95	95
	4	-	-	-	-	15	18	32	32	65	-	80	-	105	-
440V	1	-	-	-	-	-	-	-	-	-	-	-	-	-	-
	2	0.05	0.15	0.15	0.3	0.3	0.3	0.5	0.5	1	1	1	1	1	1
	3	0.13	0.3	0.3	1.5	1.5	1.5	3	3	3	3	3	3	3	3
	4	-	-	-	-	6	6	6	6	50	-	65	-	75	-
600V	1	-	-	-	-	-	-	-	-	-	-	-	-	-	-
	2	-	-	-	-	-	-	-	-	-	-	-	-	-	-
	3	-	-	-	0.8	0.8	0.8	1.5	1.5	1.5	1.5	1.5	1.5	1.5	1.5
	4	-	-	-	-	2.5	2.5	2.5	2.5	25	-	30	-	35	-

Category DC5. L/R ≤ 15ms

Ue	Poles in serie	MC0	MC1	MC2	EC09	EC12	EC18	EC25	EC32	EC40	EF50	EF65	EF80	EF95	EF105
24V	1	-	-	-	12	12	12	18	25	32	40	50	50	65	65
	2	3	4.5	4.5	18	18	18	25	40	40	65	80	80	105	105
	3	6	9	9	18	18	18	25	40	40	65	80	80	105	105
	4	-	-	-	-	18	18	25	40	-	-	80	-	105	-
48V	1	-	-	-	9	9	9	12	18	20	30	35	35	45	45
	2	2.5	4	4	18	18	18	25	40	40	65	80	80	105	105
	3	6.5	8	8	18	18	18	25	40	40	65	80	80	105	105
	4	-	-	-	-	18	18	25	40	-	-	80	-	105	-
60V	1	-	-	-	7.5	7.5	7.5	10	15	15	25	30	30	35	35
	2	2	3	3	18	18	18	25	40	40	65	80	80	105	105
	3	5	7	7	18	18	18	25	40	40	65	80	80	105	105
	4	-	-	-	-	18	18	25	40	-	-	80	-	105	-
125V	1	-	-	-	0.8	0.8	0.8	1.2	1.2	1.2	1.2	1.2	1.2	1.2	1.2
	2	0.65	1.5	1.5	5	5	5	5	5	5	50	60	60	85	85
	3	1.3	2	2	15	15	15	20	25	32	60	70	70	95	95
	4	-	-	-	-	15	18	25	32	-	-	80	-	105	-
220V	1	-	-	-	-	-	-	-	-	-	0.5	0.5	0.5	0.5	0.5
	2	0.16	0.26	0.26	0.8	0.8	0.8	0.8	0.8	0.8	3	3	3	4	4
	3	0.5	0.8	0.8	3	3	3	3	3	3	7	7	7	7	7
	4	-	-	-	-	10	10	15	15	-	-	75	-	95	-
440V	1	-	-	-	-	-	-	-	-	-	-	-	-	-	-
	2	-	-	-	-	-	-	-	-	-	-	-	-	-	-
	3	0.4	0.1	1.1	0.5	0.5	0.5	0.7	0.7	0.7	1	1	1	1	1
	4	-	-	-	-	2	2	4	4	-	-	50	-	60	-
600V	1	-	-	-	-	-	-	-	-	-	-	-	-	-	-
	2	-	-	-	-	-	-	-	-	-	-	-	-	-	-
	3	-	-	-	-	-	-	-	-	-	-	-	-	-	-
	4	-	-	-	-	0.75	0.75	2.5	2.5	-	-	25	-	30	-

Contactors for DC application

Intro
A
B
C
D
E
F
G
H
I
X



Max. operational current I_e (A) - DC utilization categories (continued)

Category DC1. $L/R \leq 1ms$

Ue	Poles in serie	CK07	CK75	CK08	CK85	CK09	CK95	CK10	CK11	CK12	CK13
24V	1	150	200	200	250	250	350	500	600	800	1000
	2	200	250	250	315	315	450	600	700	1000	1250
	3	200	250	250	315	315	450	600	700	1000	1250
	4	200	-	250	-	315	450	600	700	1000	1250
48V	1	125	170	170	200	200	295	425	500	600	850
	2	140	175	175	220	220	315	425	480	700	850
	3	200	250	250	315	315	500	600	700	1000	1250
	4	200	-	250	-	315	500	600	700	1000	1250
60V	1	100	140	140	175	175	245	350	420	560	700
	2	140	175	175	220	220	315	425	480	700	850
	3	200	250	250	315	315	500	600	700	1000	1250
	4	200	-	250	-	315	500	600	700	1000	1250
125V	1	20	25	25	30	30	50	60	70	100	125
	2	110	200	200	250	250	300	400	500	600	1000
	3	200	250	250	315	315	500	600	700	1000	1250
	4	200	-	250	-	315	500	600	700	1000	1250
220V	1	-	-	-	-	-	-	-	-	-	-
	2	65	110	110	150	150	200	250	250	300	400
	3	200	250	250	315	315	500	600	700	1000	1250
	4	200	-	250	-	315	500	600	700	1000	1250
440V	1	-	-	-	-	-	-	-	-	-	-
	2	-	-	-	-	-	-	-	-	-	-
	3	60	120	120	150	150	180	240	300	400	480
	4	110	-	200	-	250	315	400	500	700	800
600V	1	-	-	-	-	-	-	-	-	-	-
	2	-	-	-	-	-	-	-	-	-	-
	3	32	65	65	80	80	95	130	160	215	250
	4	85	-	100	-	130	170	215	265	375	430

Category DC3. $L/R \leq 2.5ms$

Ue	Poles in serie	CK07	CK75	CK08	CK85	CK09	CK95	CK10	CK11	CK12	CK13
24V	1	105	150	185	205	250	309	420	550	700	825
	2	105	150	185	205	250	309	420	550	700	825
	3	105	150	185	205	250	309	420	550	700	825
	4	105	-	185	-	250	309	420	550	700	825
48V	1	70	105	130	140	175	215	290	385	490	575
	2	105	150	185	205	250	309	420	550	700	825
	3	105	150	185	205	250	309	420	550	700	825
	4	105	-	185	-	250	309	420	550	700	825
60V	1	55	85	105	110	140	175	230	300	390	460
	2	105	150	185	205	250	309	420	550	700	825
	3	105	150	185	205	250	309	420	550	700	825
	4	105	-	185	-	250	309	420	550	700	825
125V	1	20	25	25	30	30	50	60	70	100	125
	2	105	150	185	205	250	309	420	550	700	825
	3	105	150	185	205	250	309	420	550	700	825
	4	105	-	185	-	250	309	420	550	700	825
220V	1	-	-	-	-	-	-	-	-	-	-
	2	10	60	70	80	85	95	140	185	225	400
	3	105	150	185	205	250	309	420	550	700	825
	4	105	-	185	-	250	309	420	550	700	825
440V	1	-	-	-	-	-	-	-	-	-	-
	2	-	-	-	-	-	-	-	-	-	-
	3	8	50	55	65	70	80	120	150	180	320
	4	80	-	105	-	185	205	250	300	400	700
600V	1	-	-	-	-	-	-	-	-	-	-
	2	-	-	-	-	-	-	-	-	-	-
	3	4	25	25	30	35	40	60	75	90	165
	4	40	-	50	-	90	100	125	150	200	350

Category DC5. $L/R \leq 15ms$

Ue	Poles in serie	CK07	CK75	CK08	CK85	CK09	CK95	CK10	CK11	CK12	CK13
24V	1	105	150	185	205	250	309	420	550	700	825
	2	105	150	185	205	250	309	420	550	700	825
	3	105	150	185	205	250	309	420	550	700	825
	4	105	-	185	-	250	309	420	550	700	825
48V	1	60	90	110	120	150	185	250	330	420	495
	2	105	150	185	205	250	309	420	550	700	825
	3	105	150	185	205	250	309	420	550	700	825
	4	105	-	185	-	250	309	420	550	700	825
60V	1	55	85	105	110	140	175	230	300	390	460
	2	105	150	185	205	250	309	420	550	700	825
	3	105	150	185	205	250	309	420	550	700	825
	4	105	-	185	-	250	309	420	550	700	825
125V	1	15	20	20	25	25	40	50	60	80	100
	2	80	95	105	150	185	205	250	300	400	700
	3	105	150	185	205	250	309	420	550	700	825
	4	105	-	185	-	250	309	420	550	700	825
220V	1	-	-	-	-	-	-	-	-	-	-
	2	8	50	55	65	70	80	120	150	180	320
	3	80	95	105	150	185	205	250	300	400	700
	4	105	-	185	-	250	309	420	550	700	825
440V	1	-	-	-	-	-	-	-	-	-	-
	2	-	-	-	-	-	-	-	-	-	-
	3	5	40	40	50	50	60	90	100	100	200
	4	65	-	95	-	150	185	205	250	300	400
600V	1	-	-	-	-	-	-	-	-	-	-
	2	-	-	-	-	-	-	-	-	-	-
	3	40	45	50	75	90	100	125	150	200	350
	4	35	-	45	-	75	90	100	125	150	200



Everything is under control

Horsepower and General-Use Ratings Three Pole Contactors

	Cat No.		EA	MC1	MC2	CL00	CL01	CL02	CL03	CL04	CL05	CL06	CL07	CL08	CL09	CL10
	Poles No.		3	3	3	3	3	3	3	3	3	3	3	3	3	3
General Use	600Vac	(A)	16	20	20	25	25	32	32	60	60	90	110	110	140	140
		HP	1	0.5	0.5	0.75	0.75	1	1.5	3	3	5	5	7.5	7.5	10
Single-Phase	115Vac	FLA		9.8	9.8	13.8	13.8	16.0	20.0	34.0	34.0	56.0	56.0	80.0	80.0	100
		HP	1	1.5	2	1.5	2	3	3	5	5	7.5	10	15	15	20
230Vac		FLA		10.0	12.0	10.0	12.0	17.0	17.0	28.0	28.0	40.0	50.0	68.0	68.0	88.0
		HP	3	3	3	3	3	5	5	10	10	15	20	20	25	30
200Vac		FLA		11.0	11.0	11.0	11.0	17.5	17.5	32.2	32.2	48.3	62.1	62.1	78.2	92.0
		HP	3	3	3	3	3	5	5	10	15	15	20	20	25	30
208Vac		FLA		9.6	9.6	10.6	10.6	16.7	16.7	30.8	46.2	46.2	59.4	59.4	74.8	88.0
		HP	3	3	5	3	3	5	7.5	10	15	15	20	25	30	40
230Vac		FLA		6.1	9.7	9.6	9.6	15.2	22.0	28.0	42.0	42.0	54.0	68.0	80.0	104
		HP	3	5	7.5	5	7.5	10	15	20	30	30	40	50	60	75
460Vac		FLA		7.6	11.0	7.6	11.0	14.0	21.0	27.0	40.0	40.0	52.0	65.0	77.0	96.0
		HP	3	5	10	7.5	10	15	15	25	40	40	50	60	75	75
575Vac		FLA		6.1	11.0	9.0	11.0	17.0	17.0	27.0	41.0	41.0	52.0	62.0	77.0	77.0

	Cat No.		CK75C	CK08C	CK09B	CK95B	CK10C	CK11C	CK12B
	Poles No.		3	3	3	3	3	3	3
General Use	600Vac	(A)	156	180	200	310	500	600	650A (E) 750A(O)
		HP	15	20					
Single-Phase	115Vac	FLA	135	180					
		HP	30	40					
230Vac		FLA	136	176					
		HP	40	50	60	100	125	150	200
200Vac		FLA	120	150	177	285	358	414	552
		HP	40	60	60	100	125	150	
208Vac		FLA	114	169	169	273	343	396	
		HP	50	60	75	100	150	200	250
230Vac		FLA	130	154	192	248	360	480	604
		HP	100	125	150	250	300	400	500
460Vac		FLA	124	156	180	302	361	477	590
		HP	125	125	150	300	400	500	600
575Vac		FLA	125	125	144	289	382	472	574

Horsepower and General-Use Ratings Four Pole Contactors

	Cat No.		MC1	MC2	CL00	CL01	CL02	CL03	CL04	CL05	CL06	CL07	CL08	CL09
	Poles No.		4	4	4	4	4	4	4	4	4	4	4	4
General Use	600Vac	(A)	20	20	25	25	32	45	60	90	90	110	110	140
		HP	0.5	0.5	0.75	0.75	1	2	3	3	5	5	7.5	7.5
Single-Phase	115Vac	FLA	9.8	9.8	13.8	13.8	16.0	24.0	34.0	34.0	56.0	56.0	80.0	80.0
		HP	1.5	2	1.5	2	3	3	5	7.5	7.5	10	15	15
230Vac		FLA	10.0	12.0	10.0	12.0	17.0	17.0	28.0	40.0	40.0	50.0	68.0	68.0
		HP	3	3	3	3	5	7.5	10	10	15	20	20	25
200Vac		FLA	11.0	11.0	11.0	11.0	17.5	25.3	32.2	32.2	48.3	62.1	62.1	78.2
		HP	3	3	3	3	5	7.5	10	10	15	20	20	25
208Vac		FLA	9.6	9.6	10.6	10.6	16.7	24.2	30.8	30.8	46.2	59.4	59.4	74.8
		HP	3	5	3	3	5	7.5	10	15	15	20	25	30
230Vac		FLA	6.1	9.7	9.6	9.6	15.2	22.0	28.0	42.0	42.0	54.0	68.0	80.0
		HP	5	7.5	5	7.5	10	15	20	30	30	40	50	60
460Vac		FLA	7.6	11.0	7.6	11.0	14.0	21.0	27.0	40.0	40.0	52.0	65.0	77.0
		HP	5	10	7.5	10	15	20	25	30	40	50	60	75
575Vac		FLA	6.1	11.0	9.0	11.0	17.0	22.0	27.0	32.0	41.0	52.0	62.0	77.0

	Cat No.		CK08B	CK09B	CK95B	CK12B
	Poles No.		4	4	4	4
General Use	600Vac	(A)	175	200	310	500
		HP				
Single-Phase	115Vac	FLA				
		HP				
230Vac		FLA				
		HP	50	60	100	200
200Vac		FLA	150	177	285	552
		HP		60	100	
208Vac		FLA		169	273	
		HP	60	75	100	250
230Vac		FLA	154	192	248	604
		HP	125	150	250	500
460Vac		FLA	156	180	302	590
		HP	125	150	300	600
575Vac		FLA	125	144	289	574

(E) Enclosed
(O) Open



Horsepower and General-Use Ratings Three Pole Contactors

Cat No.		EC09	EC12	EC18	EC25	EC32	EC40	EF50	EF65	EF80	EF95	EF105	
Poles No.		3	3	3	3	3	3	3	3	3	3	3	
General Use	600Vac	(A)	25	25	30	32	55	55	90	110	110	140	140
		HP	0.75	0.75	1	1.5	2	3	5	5	7.5	7.5	10
Single-Phase	115Vac	FLA	13.8	13.8	16.0	20.0	24	34	56.0	56.0	80.0	80.0	100
		HP	1.5	2	3	3	5	5	7.5	10	15	15	20
	230Vac	FLA	10.0	12.0	17.0	17.0	28	28	40.0	50.0	68.0	68.0	88.0
		HP							15	20	20	25	30
	200Vac	FLA							48.3	62.1	62.1	78.2	92.0
		HP							15	20	20	25	30
Three-Phase	208Vac	FLA							46.2	59.4	59.4	74.8	88.0
		HP	3	3	5	7.5	10	10	15	20	25	30	40
	230Vac	FLA	9.6	9.6	15.2	22	28	28	42	54.0	68.0	80.0	104
		HP	5	7.5	10	15	20	25	30	40	50	60	75
	460Vac	FLA	7.6	11	14	21	27	34	41	52.0	65.0	77.0	96.0
		HP	7.5	10	15	20	20	20	40	50	60	75	75
	575Vac	FLA	9	11	17	22	22	22	41	52.0	62.0	77.0	77.0
		HP	7.5	10	15	20	20	20					
	600Vac	FLA	9	11	17	22	22	22					

Horsepower and General-Use Ratings Four Pole Contactors

Cat No.		EC12	EC18	EC25	EC32	EF40	EF50	EF65	EF80	EF95	
Poles No.		4	4	4	4	4	4	4	4	4	
General Use	600Vac	(A)	25	30	32	55	90	90	110	110	140
		HP	0.75	1	1.5	2	3	5	5	7.5	7.5
Single-Phase	115Vac	FLA	13.8	16.0	20.0	24	34.0	56.0	56.0	80.0	80.0
		HP	2	3	3	5	7.5	7.5	10	15	15
	230Vac	FLA	12.0	17.0	17.0	28	40.0	40.0	50.0	68.0	68.0
		HP					10	15	20	20	25
	200Vac	FLA					32.2	48.3	62.1	62.1	78.2
		HP					10	15	20	20	25
Three-Phase	208Vac	FLA					30.8	46.2	59.4	59.4	74.8
		HP	3	5	7.5	10	15	15	20	25	30
	230Vac	FLA	9.6	15.2	22	28	42.0	42.0	54.0	68.0	80.0
		HP	7.5	10	15	20	30	30	40	50	60
	460Vac	FLA	11	14	21	27	40.0	40.0	52.0	65.0	77.0
		HP	10	15	20	20	30	40	50	60	75
	575Vac	FLA	11	17	22	22	32.0	41.0	52.0	62.0	77.0
		HP	10	15	20	20					
	600Vac	FLA	11	17	22	22					

Lighting Application Category

Cat No.		CL02A400T*	CL02AB00T*	CL02AA00T*	CL04A310M*	CL07A300M*	EF50E300B*	EF65E300B*
Poles No (NO+NC)		4	2+2	0+4	3	3	3	3
Ballast Rating	Amp (A)	30	30	30	30	90	90	90
	Voltage (V)	600	600	600	480/277	480/277	480/277	480/277
Tungsten Rating	Amp (A)	20	20	20	30	60	60	60
	Voltage (V)	277	277	277	480/277	480/277	480/277	480/277

Capacitor Loads Application Category

Cat No.		CSCN08	CSCN12	CSCN16	CSCN20	CSCN25	CSCN30	CSCN45	CSCN55	CSCN60	CSCN70
600Va	kVar	12	18	25	30	35	50	65	80	80	100
	A	11.5	18.0	25.1	30.1	35.1	50.2	65.2	80.3	80.3	100.4
460Va	kVar	9	15	20	25	30	40	55	70	70	90
	A	11.3	18.8	25.1	31.3	37.6	50.2	69.0	87.8	87.8	112.9
230Va	kVar	4.6	7.5	10	12.5	15	20	25	35	35	45
	A	11.5	18.8	25.1	31.3	37.6	50.2	62.7	87.8	87.8	112.9
200Va	kVar	4	6.5	7.5	10	12.5	17.5	22.5	30	30	40
	A	11.5	18.7	21.6	28.8	36.1	50.5	64.9	86.6	86.6	115.4
115Va	kVar	2.5	3.5	4.5	6	7.5	10	12.5	17	17	22.5
	A	12.5	17.6	22.6	30.1	35.1	50.2	62.7	85.3	85.3	112.9
Frame Size		1	1	1	2	2	3	4	4	4	5

High-Available Short Circuit Ratings Contactor with Fuses

M Series

Cat.No.	Max FLA	Short Circuit Current Rating		Fuse	
		kA	Volts Max.	Class	Max. Size
MC1	11	50	600	J	50A
MC2	11	50	600	J	50A

CL Series

Cat.No.	Max FLA	Short Circuit Current Rating		Fuse	
		kA	Volts Max.	Class	Max. Size
CL00	11.0	100	600	J	40A
CL01	11.0	100	600	J	40A
CL02	17.5	100	600	J	40A
CL03*3*	22.0	100	600	J	45A
CL03*4*	25.3	100	600	J	70A
CL04	32.2	100	600	J	70A
CL05*3*	34.0	100	600	J	70A
CL05*4*	42.0	100	600	J	125A
CL06	48.3	100	600	J	125A
CL07	62.1	100	600	J	125A
CL08	68.0	100	600	J	125A
CL09	80.0	100	600	J	200A
CL10	104	100	600	J	200A

CK Series

Cat.No.	Max FLA	Short Circuit Current Rating		Fuse	
		kA	Volts Max.	Class	Max. Size
CK75C	130	100	600	J	300A
CK08C	156	100	600	J	300A
CK08B	156	100	600	J	450A
CK09B	192	100	600	J	450A
CK95B	302	100	600	J	450A
CK10C	382	100	600	J	600A
CK11C	480	100	600	J	600A

Efficor Series

Cat.No.	Max FLA	Short Circuit Current Rating		Fuse	
		kA	Volts Max.	Class	Max. Size
EC09	9.6	100	600	J	35A
EC12	11	100	600	J	40A
EC18	17.5	100	600	J	40A
EC25	25.3	100	600	J	45A
EC32	32.2	100	600	J	70A
EC40	34	100	600	J	70A
EF40	42.0	100	600	J	125A
EF50	48.3	100	600	J	125A
EF65	62.1	100	600	J	125A
EF80	68.0	100	600	J	125A
EF95	80.0	100	600	J	200A
EF105	104	100	600	J	200A

High-Available Short Circuit Ratings Overload with Fuses

MT Overload Relay with Fuses

MOTOR FLA		Overload Relay	Maximum Fuse Size, Class J (A)	Max Short Circuit Rating	
Min	Max			RMS Sym (kA)	Volts
0.12	0.17	MT03A	1	50	600
0.17	0.26	MT03B	1	50	600
0.26	0.43	MT03C	1	50	600
0.43	0.65	MT03D	1	50	600
0.65	1	MT03E	3	50	600
0.85	1.3	MT03F	3	50	600
1.1	1.6	MT03G	6	50	600
1.35	2	MT03H	6	50	600
1.7	2.4	MT03I	6	50	600
2.2	3.2	MT03J	10	50	600
2.5	4	MT03R	10	50	600
3	4.7	MT03K	15	50	600
4	6.3	MT03L	20	50	600
5.5	8	MT03M	30	50	600
7.5	10.5	MT03N	40	50	600
10	14	MT03P	50	50	600

ECRT Overload Relay with Fuses

MOTOR FLA		Overload Relay	Maximum Fuse Size, Class J (A)	Max Short Circuit Rating	
Min	Max			RMS Sym (kA)	Volts
0.16	0.26	ECRT1B10B	1	100	600
0.25	0.41	ECRT1B10C	1	100	600
0.4	0.65	ECRT1B10D	1	100	600
0.65	1.1	ECRT1B10F	3	100	600
1	1.5	ECRT1B10G	6	100	600
1.3	1.9	ECRT1B10H	6	100	600
1.8	2.7	ECRT1B10J	10	100	600
2.5	4.1	ECRT1B10K	15	100	600
4	6.3	ECRT1B10L	25	100	600
5.5	8.5	ECRT1B10M	30	100	600
8	12	ECRT1B10N	45	100	600
10	16	ECRT1B10P	60	100	600
14.5	18	ECRT1B10S	70	100	600
8	12	ECRT2B10N	45	100	600
10	16	ECRT2B10P	60	100	600
14.5	18	ECRT2B10S	70	100	600
17.5	22	ECRT2B10T	70	100	600
21	26	ECRT2B10U	70	100	600
25	32	ECRT2B10V	70	100	600
30	40	ECRT2B10W	70	100	600

RT Overload Relay with Fuses

MOTOR FLA		Overload Relay	Maximum Fuse Size, Class J (A)	Max Short Circuit Rating	
Min	Max			RMS Sym (kA)	Volts
0.16	0.26	RT1B	1	100	600
0.25	0.41	RT1C	1	100	600
0.4	0.65	RT1D	1	100	600
0.65	1.1	RT1F	3	100	600
1	1.5	RT1G	6	100	600
1.3	1.9	RT1H	6	100	600
1.8	2.7	RT1J	10	100	600
2.5	4.1	RT1K	15	100	600
4	6.3	RT1L	25	100	600
5.5	8.5	RT1M	30	100	600
8	12	RT1N	40	100	600
8	12	RT1N	45	100	600
10	16	RT1P	40	100	600
10	16	RT1P	45	100	600
10	16	RT1P	60	100	600
11.5	15	RT2A	60	100	600
14.5	18	RT1S	45	100	600
14.5	18	RT1S	70	100	600
14.5	19	RT2B	70	100	600
17.5	22	RT1T	70	100	600
18.5	25	RT2C	100	100	600
21	26	RT1U	70	100	600
24	32	RT2D	125	100	600
25	32	RT1V	70	100	600
30	40	RT1W	70	100	600
30	43	RT2E	150	100	600
42	55	RT2G	200	100	600
54	65	RT2H	200	100	600
64	82	RT2J	200	100	600
78	97	RT2L	200	100	600
90	110	RT2M	200	100	600

RT Overload Relay with Fuses

MOTOR FLA		Overload Relay	Maximum Fuse Size, Class J ⁽¹⁾ (A)	Max Short Circuit Rating	
Min	Max			RMS Sym (kA)	Volts
55	80	RT3B	300	100	600
63	90	RT3C	350	100	600
90	120	RT3D	450	100	600
110	140	RT3E	450	100	600
140	190	RT3F	450	100	600
120	190	RT4N	700	100	600
175	280	RT4P	1000	100	600
200	310	RT4R	1200	100	600
120	190	RT5A	700	100	600
175	280	RT5B	1000	100	600
250	400	RT5C	1600	100	600
315	500	RT5D	2000	100	600
430	700	RT5E	2500	100	600
63	90	RT32C	350	100	600
90	120	RT32D	450	100	600
110	140	RT32E	450	100	600
140	190	RT32F	450	100	600
120	190	RT4LN	700	100	600
175	280	RT4LP	1000	100	600
200	310	RT4LR	1200	100	600
120	190	RT5LA	700	100	600
175	280	RT5LB	1000	100	600
250	400	RT5LC	1600	100	600
315	500	RT5LD	2000	100	600
430	700	RT5LE	2500	100	600

(1) RT4* and RT5* Overload Relays could be protected by Class L fuses with similar ratings

RE Overload Relay with Fuses

MOTOR FLA		Overload Relay	Maximum Fuse Size, Class J (A)	Max Short Circuit Rating	
Min	Max			RMS Sym (kA)	Volts
0.1	0.5	RE1D	1	100	600
0.4	0.2	RE1H	6	100	600
1	5	RE1K	20	100	600
1.6	8	RE1M	30	100	600
6.4	32	RE1S	70	100	600
9	45	RE1W	70	100	600
15	75	RE2H	125	100	600
22	110	RE2M	150	100	600
30	150	RE3E	300	100	600

- Intro
- A
- B
- C
- D**
- E
- F
- G
- H
- I
- X



High-Available Short Circuit Ratings Contactor with Breaker

CL Series

Cat.No.	Max FLA	Short Circuit Current Rating		GE Circuit Breaker	
		kA	Volts Max.	Model	Max. Size
CL03*4*	25.3	42	480	SEL	100A
				PEXN	
	25.3	25	480	SEH	100A
				PEXC	
				PEXE	
				SED	
25.3	18	480	PExB	100A	
			PEXC		
CL04	32.2	42	480	SEL	100A
				PEXN	
	32.2	25	480	SEH	100A
				PEXC	
				PEXE	
				SED	
32.2	18	480	PExB	100A	
			PEXC		
CL05*3*	34.0	42	480	SEL	100A
				PEXN	
	34.0	25	480	SEH	100A
				PEXC	
				PEXE	
				SED	
34.0	18	480	PExB	100A	
			PEXC		
CL05*4*	42.0	65	480	SEL	100A
				PEXN	
	42.0	25	480	SEH	100A
				PEXC	
				PEXE	
				SED	
42.0	18	480	PExB	100A	
			PEXC		
CL06	48.3	65	480	SEL	100A
				PEXN	
	48.3	25	480	SEH	100A
				PEXC	
				PEXE	
				SED	
48.3	18	480	PExB	100A	
			PEXC		
CL07	62.1	65	480	SEL	100A
				PEXN	
	62.1	25	480	SEH	100A
				PEXC	
				PEXE	
				SED	
62.1	18	480	PExB	100A	
			PEXC		
CL08	68.0	65	480	SEL	100A
				PEXN	
	68.0	25	480	SEH	100A
				PEXC	
				PEXE	
				SED	
68.0	18	480	PExB	100A	
			PEXC		
CL09	80.0	42	480	SEL	150A
				PEXN	
	80.0	25	480	SEH	150A
				PEXC	
				PEXE	
				SED	
80.0	18	480	PExB	150A	
			PEXC		
CL10	104	42	480	SEL	150A
				PEXN	
	104	25	480	SEH	150A
				PEXC	
				PEXE	
				SED	
104	18	480	PExB	150A	
			PEXC		

UL Applications

Intro

A

B

C

D

E

F

G

H

I

X



High-Available Short Circuit Ratings Contactor with Breaker

CL Series

Cat.No.	Max FLA	Short Circuit Current Rating		GE Circuit Breaker	
		kA	Volts Max.	Model	Max. Size
CL00	11.0	65	120 1ph	TEY	20A
CL01	11.0	65	120 1ph	TEY	20A
CL02	17.5	65	120 1ph	TEY	20A

CK Series

Cat.No.	Max FLA	Short Circuit Current Rating		GE Circuit Breaker	
		kA	Volts Max.	Model	Max. Size
CK75C	130	65	480	SFL	150 A
				PEXN	
	130	25	480	SFH	150 A
				PEXC	
CK08C	156	65	480	SFL	150 A
				PEXN	
	156	25	480	SFH	150 A
				PEXC	
CK08B	156	65	480	SGL	600A
				SGH	
	156	35	480	SGL	600A
				SGH	
CK09B	192	65	480	PGxN	600A
				PGxH	
	192	35	480	SGH	600A
				PGxE	
CK95B	302	65	480	SGL	600A
				PGxN	
	302	35	480	SGH	600A
				PGxE	
CK10C	382	65	480	SGL	600 A
				PGxN	
	382	35	480	SGH	600 A
				PGxE	
CK11C	480	65	480	SGL	600 A
				PGxN	
	480	35	480	SGH	600 A
				PGxE	

High-Available Short Circuit Ratings Contactor with Breaker

Efficor Series

Cat.No.	Max FLA	Short Circuit Current Rating		GE Circuit Breaker		Cat.No.	Max FLA	Short Circuit Current Rating		GE Circuit Breaker	
		kA	Volts Max.	Model	Max. Size			kA	Volts Max.	Model	Max. Size
EC09	9.6	30	480	SEL	35A	EC09	9.6	30	240	SEL	35A
				PEXN						SEH	
				PEXE						PEXN	
EC12	11	30	480	PEXC	40A	EC12	11	30	240	PEXE	40A
				SED						SEH	
				PEXB						PEXN	
EC18	17.5	30	480	PEXC	60A	EC18	17.5	30	240	PEXE	60A
				SED						SEH	
				PEXB						PEXN	
EC25	25.3	30	480	PEXC	100A	EC25	25.3	30	240	PEXE	100A
				SED						SEH	
				PEXB						PEXN	
EC32	32.2	30	480	PEXC	110A	EC32	32.2	30	240	PEXE	110A
				SED						SEH	
				PEXB						PEXN	
EC40	34	30	480	PEXC	125A	EC40	34	30	240	PEXE	125A
				SED						SEH	
				PEXB						PEXN	
EF40	42.0	65	480	PEXC	100A	EF40	42.0	65	240	PEXE	100A
				SED						SEH	
				PEXB						PEXN	
EF50	48.3	65	480	PEXC	100A	EF50	48.3	65	240	PEXE	100A
				SED						SEH	
				PEXB						PEXN	
EF65	62.1	65	480	PEXC	100A	EF65	62.1	65	240	PEXE	100A
				SED						SEH	
				PEXB						PEXN	
EF80	68.0	65	480	PEXC	100A	EF80	68.0	65	240	PEXE	100A
				SED						SEH	
				PEXB						PEXN	
EF95	80.0	42	480	PEXC	150A	EF95	80.0	42	240	PEXE	150A
				SED						SEH	
				PEXB						PEXN	
EF105	104	42	480	PEXC	150A	EF105	104	42	240	PEXE	150A
				SED						SEH	
				PEXB						PEXN	

UL Applications

- Intro
- A
- B
- C
- D
- E
- F
- G
- H
- I
- X



High-Available Short Circuit Ratings Contactor with Fuses and Overload Relay

MT Thermal Overload Relays with M Contactors

MOTOR FLA		Overload Relay	Max Short Circuit Rating		Maximum Fuse Size Class J (A)	
Min	Max ⁽¹⁾		RMS Sym (kA)	Volts	MC1	MC2
0.12	0.17	MT03A	50	600	1	1
0.17	0.26	MT03B	50	600	1	1
0.26	0.43	MT03C	50	600	1	1
0.43	0.65	MT03D	50	600	1	1
0.65	1	MT03E	50	600	3	3
0.85	1.3	MT03F	50	600	3	3
1.1	1.6	MT03G	50	600	6	6
1.35	2	MT03H	50	600	6	6
1.7	2.4	MT03I	50	600	6	6
2.2	3.2	MT03J	50	600	10	10
2.5	4	MT03R	50	600	10	10
3	4.7	MT03K	50	600	15	15
4	6.3	MT03L	50	600	20	20
5.5	8	MT03M	50	600	30	30
7.5	10.5	MT03N	50	600	40	40
10	14	MT03P	50	600	50	50

(1) Do not exceed contactor current rating when selecting and adjusting overload relays.
For separate mount use adapter MVB0T.

RT Thermal Overload Relays with CL Contactors

MOTOR FLA		Overload Relay	Max Short Circuit Rating		Maximum Fuse Size Class J (A)										
Min	Max ⁽¹⁾		RMS Sym (kA)	Volts	CL00	CL01	CL02	CL03	CL04	CL05	CL06	CL07	CL08	CL09	CL10
0.16	0.26	RT1B	100	600	1	1	1	1	1	1	-	-	-	-	-
0.25	0.41	RT1C	100	600	1	1	1	1	1	1	-	-	-	-	-
0.4	0.65	RT1D	100	600	1	1	1	1	1	1	-	-	-	-	-
0.65	1.1	RT1F	100	600	3	3	3	3	3	3	-	-	-	-	-
1	1.5	RT1G	100	600	6	6	6	6	6	6	-	-	-	-	-
1.3	1.9	RT1H	100	600	6	6	6	6	6	6	-	-	-	-	-
1.8	2.7	RT1J	100	600	10	10	10	10	10	10	-	-	-	-	-
2.5	4.1	RT1K	100	600	15	15	15	15	15	15	-	-	-	-	-
4	6.3	RT1L	100	600	25	25	25	25	25	25	-	-	-	-	-
5.5	8.5	RT1M	100	600	30	30	30	30	30	30	-	-	-	-	-
8	12	RT1N	100	600	40	40	45	45	45	45	-	-	-	-	-
10	16	RT1P	100	600	-	-	40	45	60	60	-	-	-	-	-
14.5	18	RT1S	100	600	-	-	-	45	70	70	-	-	-	-	-
17.5	22	RT1T	100	600	-	-	-	-	70	70	-	-	-	-	-
21	26	RT1U	100	600	-	-	-	-	70	70	-	-	-	-	-
25	32	RT1V	100	600	-	-	-	-	70	70	-	-	-	-	-
30	40	RT1W	100	600	-	-	-	-	-	70	-	-	-	-	-
11.5	15	RT2A	100	600	-	-	-	-	-	-	60	-	60	60	60
14.5	19	RT2B	100	600	-	-	-	-	-	-	70	70	70	70	70
18.5	25	RT2C	100	600	-	-	-	-	-	-	100	100	100	100	100
24	32	RT2D	100	600	-	-	-	-	-	-	125	125	125	125	125
30	43	RT2E	100	600	-	-	-	-	-	-	125	125	125	150	150
42	55	RT2G	100	600	-	-	-	-	-	-	-	125	125	200	200
54	65	RT2H	100	600	-	-	-	-	-	-	-	-	125	200	200
64	82	RT2J	100	600	-	-	-	-	-	-	-	-	-	200	200
78	97	RT2L	100	600	-	-	-	-	-	-	-	-	-	-	200
90	110	RT2M	100	600	-	-	-	-	-	-	-	-	-	-	200

(1) Do not exceed contactor current rating when selecting and adjusting overload relays.
For separate mount use base adapter RT1XP or RT2XP.

RE Electronic Overload Relays with Effcor Contactors

MOTOR FLA		Overload Relay	Max Short Circuit Rating		Maximum Fuse Size Class J (A)											
Min	Max ⁽¹⁾		RMS Sym (kA)	Volts	CL00	CL01	CL02	CL03	CL04	CL05	CL06	CL07	CL08	CL09	CL10	CK75C
0.1	0.5	RE1D	100	600	1	1	1	1	1	1	-	-	-	-	-	-
0.4	0.2	RE1H	100	600	6	6	6	6	6	6	-	-	-	-	-	-
1	5	RE1K	100	600	20	20	20	20	20	20	-	-	-	-	-	-
1.6	8	RE1M	100	600	30	30	30	30	30	30	-	-	-	-	-	-
6.4	32	RE1S	100	600	40	40	40	45	70	70	-	-	-	-	-	-
9	45	RE1W	100	600	-	-	45	45	70	70	-	-	-	-	-	-
15	75	RE2H	100	600	-	-	-	-	-	-	125	125	125	125	125	-
22	110	RE2M	100	600	-	-	-	-	-	-	125	125	125	150	150	-
30	150	RE3E	100	600	-	-	-	-	-	-	-	-	-	-	-	300

(1) Do not exceed contactor current rating when selecting and adjusting overload relays.
For separate mount use base adapter RE1XP or RE2XP.



High-Available Short Circuit Ratings Contactor with Fuses and Overload Relay

RT Thermal Overload Relays with CK Contactors

MOTOR FLA		Overload Relay	Max Short Circuit Rating				Maximum Fuse Size Class J (A)				
Min	Max ⁽¹⁾		RMS Sym (kA)	Volts	CK75C	CK08C	CK09B	CK95B	CK10C	CK11C	
55	80	RT3B	100	600	300	300	-	-	-	-	
63	90	RT3C	100	600	300	300	-	-	-	-	
90	120	RT3D	100	600	300	300	-	-	-	-	
110	140	RT3E	100	600	300	300	-	-	-	-	
140	190	RT3F	100	600	-	300	-	-	-	-	
120	190	RT4N	100	600	-	-	450	450	-	-	
175	280	RT4P	100	600	-	-	450	450	-	-	
200	310	RT4R	100	600	-	-	-	450	-	-	
120	190	RT5A	100	600	-	-	-	-	600	600	
175	280	RT5B	100	600	-	-	-	-	600	600	
250	400	RT5C	100	600	-	-	-	-	600	600	
315	500	RT5D	100	600	-	-	-	-	600	600	
430	700	RT5E	100	600	-	-	-	-	-	600	
63	90	RT32C	100	600	300	300	-	-	-	-	
90	120	RT32D	100	600	300	300	-	-	-	-	
110	140	RT32E	100	600	300	300	-	-	-	-	
140	190	RT32F	100	600	-	300	-	-	-	-	
120	190	RT4LN	100	600	-	-	450	450	-	-	
175	280	RT4LP	100	600	-	-	450	450	-	-	
200	310	RT4LR	100	600	-	-	-	450	-	-	
120	190	RT5LA	100	600	-	-	-	-	600	600	
175	280	RT5LB	100	600	-	-	-	-	600	600	
250	400	RT5LC	100	600	-	-	-	-	600	600	
315	500	RT5LD	100	600	-	-	-	-	600	600	
430	700	RT5LE	100	600	-	-	-	-	-	600	

(1) Do not exceed contactor current rating when selecting and adjusting overload relays.
RT4* and RT5* Overload Relays are separate mount

ECRT and RT Thermal Overload Relays with Efficor Contactors

MOTOR FLA		Overload Relay	Max Short Circuit Rating				Maximum Fuse Size Class J (A)									
Min	Max ⁽¹⁾		RMS Sym (kA)	Volts	EC09	EC12	EC18	EC25	EC32	EC40	EF50	EF65	EF80	EF95	EF105	
0.16	0.26	ECRT1B10B	100	600	1	1	1	-	-	-	-	-	-	-	-	
0.25	0.41	ECRT1B10C	100	600	1	1	1	-	-	-	-	-	-	-	-	
0.4	0.65	ECRT1B10D	100	600	1	1	1	-	-	-	-	-	-	-	-	
0.65	1.1	ECRT1B10F	100	600	3	3	3	-	-	-	-	-	-	-	-	
1	1.5	ECRT1B10G	100	600	6	6	6	-	-	-	-	-	-	-	-	
1.3	1.9	ECRT1B10H	100	600	6	6	6	-	-	-	-	-	-	-	-	
1.8	2.7	ECRT1B10J	100	600	10	10	10	-	-	-	-	-	-	-	-	
2.5	4.1	ECRT1B10K	100	600	15	15	15	-	-	-	-	-	-	-	-	
4	6.3	ECRT1B10L	100	600	25	25	25	-	-	-	-	-	-	-	-	
5.5	8.5	ECRT1B10M	100	600	30	30	30	-	-	-	-	-	-	-	-	
8	12	ECRT1B10N	100	600	35	40	40	-	-	-	-	-	-	-	-	
10	16	ECRT1B10P	100	600	-	-	40	-	-	-	-	-	-	-	-	
14.5	18	ECRT1B10S	100	600	-	-	40	-	-	-	-	-	-	-	-	
8	12	ECRT2B10N	100	600	-	-	-	45	45	45	-	-	-	-	-	
10	16	ECRT2B10P	100	600	-	-	-	45	60	60	-	-	-	-	-	
14.5	18	ECRT2B10S	100	600	-	-	-	-	70	70	-	-	-	-	-	
17.5	22	ECRT2B10T	100	600	-	-	-	-	-	70	-	-	-	-	-	
21	26	ECRT2B10U	100	600	-	-	-	-	-	70	-	-	-	-	-	
25	32	ECRT2B10V	100	600	-	-	-	-	-	70	-	-	-	-	-	
30	40	ECRT2B10W	100	600	-	-	-	-	-	70	-	-	-	-	-	
11.5	15	RT2A	100	600	-	-	-	-	-	-	60	60	60	60	60	
14.5	19	RT2B	100	600	-	-	-	-	-	-	70	70	70	70	70	
18.5	25	RT2C	100	600	-	-	-	-	-	-	100	100	100	100	100	
24	32	RT2D	100	600	-	-	-	-	-	-	125	125	125	125	125	
30	43	RT2E	100	600	-	-	-	-	-	-	125	125	125	150	150	
42	55	RT2G	100	600	-	-	-	-	-	-	-	125	125	200	200	
54	65	RT2H	100	600	-	-	-	-	-	-	-	-	125	200	200	
64	82	RT2J	100	600	-	-	-	-	-	-	-	-	-	200	200	
78	97	RT2L	100	600	-	-	-	-	-	-	-	-	-	-	200	
90	110	RT2M	100	600	-	-	-	-	-	-	-	-	-	-	200	

(1) Do not exceed contactor current rating when selecting and adjusting overload relays.
For separate mount use base adapter ECRT1BS, ECRT2BS or RT2XP.

RE Electronic Overload Relays with Efficor Contactors

MOTOR FLA		Overload Relay	Max Short Circuit Rating				Maximum Fuse Size Class J (A)									
Min	Max ⁽¹⁾		RMS Sym (kA)	Volts	EC09	EC12	EC18	EC25	EC32	EC40	EF50	EF65	EF80	EF95	EF105	
0.1	0.5	RE1D	100	600	1	1	1	1	1	1	-	-	-	-	-	
0.4	0.2	RE1H	100	600	6	6	6	6	6	6	-	-	-	-	-	
1	5	RE1K	100	600	20	20	20	20	20	20	-	-	-	-	-	
1.6	8	RE1M	100	600	30	30	30	30	30	30	-	-	-	-	-	
6.4	32	RE1S	100	600	35	40	40	45	70	70	-	-	-	-	-	
9	45	RE1W	100	600	-	-	40	45	70	70	-	-	-	-	-	
15	75	RE2H	100	600	-	-	-	-	-	-	125	125	125	125	125	
22	110	RE2M	100	600	-	-	-	-	-	-	125	125	125	150	150	

(1) Do not exceed contactor current rating when selecting and adjusting overload relays.
For separate mount use base adapter RE1XP or RE2XP.



High-Available Short Circuit Ratings Contactor with Breaker and Thermal Overload

CL Series

Cat.No.	Max FLA	O/L Relay	Short Circuit Current Rating		GE Circuit Breaker	
			kA	Volts Max.	Model	Max. Size
CL03*4*	25.3	RT1, RT12	42	480	SEL PEXN	100A
	25.3	RT1, RT12	25	480	SEH	100A
					PEXC	
					PExE	
	25.3	RT1, RT12	18	480	SED PExB	100A
					PExB	
CL04	32.2	RT1, RT12	42	480	SEL PEXN	100A
	32.2	RT1, RT12	25	480	SEH	100A
					PEXC	
					PExE	
	32.2	RT1, RT12	18	480	SED PExB	100A
					PExB	
CL05*3*	34.0	RT1, RT12	42	480	SEL PEXN	100A
	34.0	RT1, RT12	25	480	SEH	100A
					PEXC	
					PExE	
	34.0	RT1, RT12	18	480	SED PExB	100A
					PExB	
CL05*4*	42.0	RT2, RT22	65	480	SEL PEXN	100A
	42.0	RT2, RT22	25	480	SEH	100A
					PEXC	
					PExE	
	42.0	RT2, RT22	18	480	SED PExB	100A
					PExB	
CL06	48.3	RT2, RT22	65	480	SEL PEXN	100A
	48.3	RT2, RT22	25	480	SEH	100A
					PEXC	
					PExE	
	48.3	RT2, RT22	18	480	SED PExB	100A
					PExB	
CL07	62.1	RT2, RT22	65	480	SEL PEXN	100A
	62.1	RT2, RT22	25	480	SEH	100A
					PEXC	
					PExE	
	62.1	RT2, RT22	18	480	SED PExB	100A
					PExB	
CL08	68.0	RT2, RT22	65	480	SEL PEXN	100A
	68.0	RT2, RT22	25	480	SEH	100A
					PEXC	
					PExE	
	68.0	RT2, RT22	18	480	SED PExB	100A
					PExB	
CL09	80.0	RT2, RT22	65	480	SEL PEXN	150A
	80.0	RT2, RT22	25	480	SEH	150A
					PEXC	
					PExE	
	80.0	RT2, RT22	18	480	SED PExB	150A
					PExB	
CL10	104	RT2, RT22	65	480	SEL PEXN	150A
	104	RT2, RT22	25	480	SEH	150A
					PEXC	
					PExE	
	104	RT2, RT22	18	480	SED PExB	150A
					PExB	

UL Applications

Intro

A

B

C

D

E

F

G

H

I

X



High-Available Short Circuit Ratings Contactor with Breaker and Thermal Overload

CK Series

Cat.No.	Max FLA	O/L Relay	Short Circuit Current Rating		GE Circuit Breaker	
			kA	Volts Max.	Model	Max. Size
CK75C	130	RT3P, RT32P	65	480	SFL	250 A
					PE×N	
	130	RT3P, RT32P	25	480	SFH	250 A
					PE×C	
					PE×E	
CK08C	156	RT3P, RT32P	65	480	SFL	250 A
					PE×N	
	156	RT3P, RT32P	25	480	SFH	250 A
					PE×C	
					PE×E	
CK10C	382	RT5, RT5L	65	480	SGL	600A
					PG×N	
	382	RT5, RT5L	35	480	PG×H	600A
					SGH	
					PG×E	
CK11C	480	RT5, RT5L	65	480	SGL	600A
					PG×N	
	480	RT5, RT5L	35	480	PG×H	600A
					SGH	
					PG×E	

High-Available Short Circuit Ratings Contactor with Breaker and Thermal Overload

Effcor Series

Cat.No.	Max FLA	O/L Relay	Short Circuit Current Rating		GE Circuit Breaker	
			kA	Volts Max.	Model	Max. Size
EC09	9.6	ECRT1	30	480	SEL PEXN PEXE	40A
	9.6	ECRT1	25	480	SEH PEXC	40A
	9.6	ECRT1	18	480	SED PEXB	40A
EC12	11	ECRT1	30	480	SEL PEXN PEXE	40A
	11	ECRT1	25	480	SEH PEXC	40A
	11	ECRT1	18	480	SED PEXB	40A
EC18	17.5	ECRT1	30	480	SEL PEXN PEXE	70A
	17.5	ECRT1	25	480	SEH PEXC	70A
	17.5	ECRT1	18	480	SED PEXB	70A
EC25	25.3	ECRT2	30	480	SEL PEXN PEXE	100A
	25.3	ECRT2	25	480	SEH PEXC	100A
	25.3	ECRT2	18	480	SED PEXB	100A
EC32	32.2	ECRT2	42	480	SEL PEXN PEXE	100A
	32.2	ECRT2	35	480	SEH PEXC	100A
	32.2	ECRT2	18	480	SED PEXB	100A
EC40	34	ECRT2	42	480	SEL PEXN PEXE	100A
	34	ECRT2	35	480	SEH PEXC	100A
	34	ECRT2	25	480	SED PEXB	100A
	34	ECRT2	18	480	SEL PEXN PEXE	100A
EF40	42.0	RT2, RT22	65	480	SEL PEXN SEH PEXC	100A
	42.0	RT2, RT22	25	480	PEXE	100A
	42.0	RT2, RT22	18	480	SED PEXB	100A
EF50	48.3	RT2, RT22	65	480	SEL PEXN SEH PEXC	100A
	48.3	RT2, RT22	25	480	PEXE	100A
	48.3	RT2, RT22	18	480	SED PEXB	100A
EF65	62.1	RT2, RT22	65	480	SEL PEXN SEH PEXC	100A
	62.1	RT2, RT22	25	480	PEXE	100A
	62.1	RT2, RT22	18	480	SED PEXB	100A
EF80	68.0	RT2, RT22	65	480	SEL PEXN SEH PEXC	100A
	68.0	RT2, RT22	25	480	PEXE	100A
	68.0	RT2, RT22	18	480	SED PEXB	100A
EF95	80.0	RT2, RT22	65	480	SEL PEXN SEH PEXC	150A
	80.0	RT2, RT22	25	480	PEXE	150A
	80.0	RT2, RT22	18	480	SED PEXB	150A
EF105	104	RT2, RT22	65	480	SEL PEXN SEH PEXC	150A
	104	RT2, RT22	25	480	PEXE	150A
	104	RT2, RT22	18	480	SED PEXB	150A

UL Applications

Intro

A

B

C

D

E

F

G

H

I

X





Combination Motor Controllers

Surion Manual Motor Controller

Construction Type	Max. Motor HP Rating				Max. Motor FLA				SCCR (kA)	Manual Motor Controller			GE Cat. No. Component List						
	200V	208V	230V	460V	200V	208V	230V	460V		240 V	480V/277 V	GE Cat. No.	Motor Current Adjust Range		Contactor	Feed-in Terminals	SC Alarm	Link Module	Base Plate
											Min. (A)	Max. (A)							
-	E	-	-	-	-	0.16	0.16	0.16	0.16	-	50	GPS1BHAA	0.1	0.16	-	-	-	-	-
-	E	-	-	-	-	0.25	0.25	0.25	0.25	-	50	GPS1BHAB	0.16	0.25	-	-	-	-	-
-	E	-	-	-	-	0.4	0.4	0.4	0.4	-	50	GPS1BHAC	0.25	0.4	-	-	-	-	-
-	E	-	-	-	-	0.63	0.63	0.63	0.63	-	50	GPS1BHAD	0.4	0.63	-	-	-	-	-
-	E	-	-	-	0.5	1	1	1	1.1	-	50	GPS1BHA E	0.63	1	-	-	-	-	-
-	E	0.25	0.25	0.33	0.75	1.6	1.6	1.6	1.6	-	50	GPS1BHAF	1	1.6	-	-	-	-	-
-	E	0.5	0.5	0.5	1	2.5	2.4	2.2	2.1	-	50	GPS1BHAG	1.6	2.5	-	-	-	-	-
-	E	0.75	0.75	0.75	2	3.7	3.5	3.2	3.4	-	50	GPS1BHAH	2.5	4	-	GPAPT1E	GPAE11LLA	-	-
-	E	1	1	1.5	3	4.8	4.6	6	4.8	-	50	GPS1BHAJ	4	6.3	-	-	-	-	-
-	E	2	2	3	5	7.8	7.5	9.6	7.6	-	50	GPS1BHA K	6.3	10	-	-	-	-	-
-	E	3	3	3	5	11	10.6	9.6	11	-	50	GPS1BHAL	9	13	-	-	-	-	-
-	E	3	3	3	5	11	10.6	15.2	14	-	50	GPS1BHAM	11	16	-	-	-	-	-
-	E	5	5	5	10	17.5	16.7	15.2	14	-	50	GPS1BHAN	14	20	-	-	-	-	-
-	E	7.5	7.5	7.5	15	25.3	24.2	22	21	-	50	GPS1BHAP	19	25	-	-	-	-	-
-	E	10	10	10	20	32.2	30.8	28	27	-	50	GPS1BHAR	24	32	-	-	-	-	-
-	E	2	2	3	5	7.8	7.5	9.6	7.6	-	50	GPS2BHK	6.3	10	-	-	-	-	-
-	E	3	3	3	5	11	10.6	9.6	11	-	50	GPS2BHL	9	13	-	-	-	-	-
-	E	3	3	3	5	11	10.6	15.2	11	-	50	GPS2BHM	11	16	-	-	-	-	-
-	E	5	5	5	10	17.5	16.7	15.2	14	-	50	GPS2BHN	14	20	-	-	-	-	-
-	E	7.5	7.5	7.5	15	25.3	24.2	22	21	-	50	GPS2BHP	19	25	-	-	GP AE11LLA	-	-
-	E	10	10	10	20	32.2	30.8	28	27	-	50	GPS2BHR	24	32	-	-	-	-	-
-	E	10	10	10	25	32.2	30.8	28	34	-	50	GPS2BHS	28	40	-	-	-	-	-
-	E	15	15	15	30	48.3	46.2	42	40	-	50	GPS2BHT	35	50	-	-	-	-	-
-	E	15	15	20	40	48.3	46.2	54	52	-	50	GPS2BHU	45	63	-	-	-	-	-

Surion Combination with Contactor M series

Construction Type	Max. Motor HP Rating				Max. Motor FLA				SCCR (kA)	Manual Motor Controller			GE Cat. No. Component List							
	200V	208V	230V	460V	200V	208V	230V	460V		240 V	480V/277 V	GE Cat. No.	Motor Current Adjust Range		Contactor	Feed-in Terminals	SC Alarm	Link Module	Base Plate	
											Min. (A)	Max. (A)								
-	F	-	-	-	-	0.16	0.16	0.16	0.16	-	50	GPS1BHAA	0.1	0.16	-	-	-	-	-	
-	F	-	-	-	-	0.25	0.25	0.25	0.25	-	50	GPS1BHAB	0.16	0.25	-	-	-	-	-	
-	F	-	-	-	-	0.4	0.4	0.4	0.4	-	50	GPS1BHAC	0.25	0.4	-	-	-	-	-	
-	F	-	-	-	-	0.63	0.63	0.63	0.63	-	50	GPS1BHAD	0.4	0.63	-	-	-	-	-	
-	F	-	-	-	0.5	1	1	1	1.1	-	50	GPS1BHA E	0.63	1	-	-	-	-	-	
-	F	0.25	0.25	0.33	0.75	1.6	1.6	1.6	1.6	-	50	GPS1BHAF	1	1.6	-	-	-	-	-	
-	F	0.5	0.5	0.5	1	2.5	2.4	2.2	2.1	-	50	GPS1BHAG	1.6	2.5	-	-	-	-	-	
-	F	0.75	0.75	0.75	2	3.7	3.5	3.2	3.4	-	50	GPS1BHAH	2.5	4	-	MC1[*] 310AT[**]	GPAPT1E	GP AE11LLA	GPFLMCBA	-
-	F	1	1	1.5	3	4.8	4.6	6	4.8	-	50	GPS1BHAJ	4	6.3	-	-	-	-	-	
-	F	2	2	3	5	7.8	7.5	9.6	7.6	-	50	GPS1BHA K	6.3	10	-	-	-	-	-	
-	F	3	3	3	5	11	10.6	9.6	7.6	-	50	GPS1BHAL	9	13	-	-	-	-	-	
-	F	3	3	3	5	11	10.6	9.6	7.6	-	50	GPS1BHAM	11	16	-	-	-	-	-	
-	F	3	3	3	5	11	10.6	9.6	7.6	-	50	GPS1BHAN	14	20	-	-	-	-	-	
-	F	3	3	3	5	11	10.6	9.6	7.6	-	50	GPS1BHAP	19	25	-	-	-	-	-	
-	F	3	3	3	5	11	10.6	9.6	7.6	-	50	GPS1BHAR	24	32	-	-	-	-	-	

Surion GPS1 Combination with Contactor CL series

Construction Type	Max. Motor HP Rating				Max. Motor FLA				SCCR (kA)	Manual Motor Controller			GE Cat. No. Component List							
	200V	208V	230V	460V	200V	208V	230V	460V		240 V	480V/277 V	GE Cat. No.	Motor Current Adjust Range		Contactor	Feed-in Terminals	SC Alarm	Link Module	Base Plate	
											Min. (A)	Max. (A)								
-	F	-	-	-	-	0.16	0.16	0.16	0.16	-	50	GPS1BHAA	0.1	0.16	-	-	-	-	-	
-	F	-	-	-	-	0.25	0.25	0.25	0.25	-	50	GPS1BHAB	0.16	0.25	-	-	-	-	-	
-	F	-	-	-	-	0.4	0.4	0.4	0.4	-	50	GPS1BHAC	0.25	0.4	-	-	-	-	-	
-	F	-	-	-	-	0.63	0.63	0.63	0.63	-	50	GPS1BHAD	0.4	0.63	-	-	-	-	-	
-	F	-	-	-	0.5	1	1	1	1.1	-	50	GPS1BHA E	0.63	1	-	-	-	-	-	
-	F	0.25	0.25	0.33	0.75	1.6	1.6	1.6	1.6	-	50	GPS1BHAF	1	1.6	-	-	-	-	-	
-	F	0.5	0.5	0.5	1	2.5	2.4	2.2	2.1	-	50	GPS1BHAG	1.6	2.5	-	-	-	-	-	
-	F	0.75	0.75	0.75	2	3.7	3.5	3.2	3.4	-	50	GPS1BHAH	2.5	4	-	CL00[*] 310T[**]	GPAPT1E	GP AE11LLA	GPFL02AA	GPFB1A
-	F	1	1	1.5	3	4.8	4.6	6	4.8	-	50	GPS1BHAJ	4	6.3	-	-	-	-	-	
-	F	2	2	3	5	7.8	7.5	9.6	7.6	-	50	GPS1BHA K	6.3	10	-	-	-	-	-	
-	F	3	3	3	5	11	10.6	9.6	7.6	-	50	GPS1BHAL	9	13	-	-	-	-	-	
-	F	3	3	3	5	11	10.6	9.6	7.6	-	50	GPS1BHAM	11	16	-	-	-	-	-	
-	F	3	3	3	5	11	10.6	9.6	7.6	-	50	GPS1BHAN	14	20	-	-	-	-	-	
-	F	3	3	3	5	11	10.6	9.6	7.6	-	50	GPS1BHAP	19	25	-	-	-	-	-	
-	F	3	3	3	5	11	10.6	9.6	7.6	-	50	GPS1BHAR	24	32	-	-	-	-	-	
-	F	-	-	-	-	0.16	0.16	0.16	0.16	-	50	GPS1BHAA	0.1	0.16	-	-	-	-	-	
-	F	-	-	-	-	0.25	0.25	0.25	0.25	-	50	GPS1BHAB	0.16	0.25	-	-	-	-	-	
-	F	-	-	-	-	0.4	0.4	0.4	0.4	-	50	GPS1BHAC	0.25	0.4	-	-	-	-	-	
-	F	-	-	-	-	0.63	0.63	0.63	0.63	-	50	GPS1BHAD	0.4	0.63	-	-	-	-	-	
-	F	-	-	-	0.5	1	1	1	1.1	-	50	GPS1BHA E	0.63	1	-	-	-	-	-	
-	F	0.25	0.25	0.33	0.75	1.6	1.6	1.6	1.6	-	50	GPS1BHAF	1	1.6	-	-	-	-	-	
-	F	0.5	0.5	0.5	1	2.5	2.4	2.2	2.1	-	50	GPS1BHAG	1.6	2.5	-	-	-	-	-	
-	F	0.75	0.75	0.75	2	3.7	3.5	3.2	3.4	-	50	GPS1BHAH	2.5	4	-	CL01[*] 310T[**]	GPAPT1E	GP AE11LLA	GPFL02AA	GPFB1A
-	F	1	1	1.5	3	4.8	4.6	6	4.8	-	50	GPS1BHAJ	4	6.3	-	-	-	-	-	
-	F	2	2	3	5	7.8	7.5	9.6	7.6	-	50	GPS1BHA K	6.3	10	-	-	-	-	-	
-	F	3	3	3	5	11	10.6	9.6	11	-	50	GPS1BHAL	9	13	-	-	-	-	-	
-	F	3	3	3	5	11	10.6	9.6	11	-	50	GPS1BHAM	11	16	-	-	-	-	-	
-	F	3	3	3	5	11	10.6	9.6	11	-	50	GPS1BHAN	14	20	-	-	-	-	-	
-	F	3	3	3	5	11	10.6	9.6	11	-	50	GPS1BHAP	19	25	-	-	-	-	-	
-	F	3	3	3	5	11	10.6	9.6	11	-	50	GPS1BHAR	24	32	-	-	-	-	-	
-	F	-	-	-	-	0.16	0.16	0.16	0.16	-	50	GPS1BHAA	0.1	0.16	-	-	-	-	-	
-	F	-	-	-	-	0.25	0.25	0.25	0.25	-	50	GPS1BHAB	0.16	0.25	-	-	-	-	-	
-	F	-	-	-	-	0.4	0.4	0.4	0.4	-	50	GPS1BHAC	0.25	0.4	-	-	-	-	-	
-	F	-	-	-	-	0.63	0.63	0.63	0.63	-	50	GPS1BHAD	0.4	0.63	-	-	-	-	-	
-	F	-	-	-	0.5	1	1	1	1.1	-	50	GPS1BHA E	0.63	1	-	-	-	-	-	
-	F	0.25	0.25	0.33	0.75	1.6	1.6	1.6	1.6	-	50	GPS1BHAF	1	1.6	-	-	-	-	-	
-	F	0.5	0.5	0.5	1	2.5	2.4	2.2	2.1	-	50	GPS1BHAG	1.6	2.5	-	-	-	-	-	
-	F	0.75	0.75	0.75	2	3.7	3.5	3.2	3.4	-	50	GPS1BHAH	2.5	4	-	CL02[*] 310T[**]	GPAPT1E	GP AE11LLA	GPFL02AA	GPFB1A
-	F	1	1	1.5	3	4.8	4.6	6	4.8	-	50	GPS1BHAJ	4	6.3	-	-	-	-	-	
-	F	2	2	3	5	7.8	7.5	9.6	7.6	-	50	GPS1BHA K	6.3	10	-	-	-	-	-	
-	F	3	3	3	5	11	10.6	9.6	11	-	50	GPS1BHAL								

Combination Motor Controllers

Surion GPS1 Combination with Contactor CL series

Construction Type		Max. Motor HP Rating				Max. Motor FLA				SCCR (kA)		Manual Motor Controller		GE Cat. No. Component List					
240V	480V/277V	200V	208V	230V	460V	200V	208V	230V	460V	240 V	480V/277 V	GE Cat. No.	Motor Current Adjust Range		Contactor	Feed-in Terminals	SC Alarm	Link Module	Base Plate
												Min. (A)	Max. (A)						
-	F	-	-	-	-	0.16	0.16	0.16	0.16	-	50	GPS1BHAA	0.1	0.16	CL03[*] 300T[**]	GPAPT1E	GPAE11LLA	GPF1L25AA	GPF1B1A
-	F	-	-	-	-	0.25	0.25	0.25	0.25	-	50	GPS1BHAB	0.16	0.25					
-	F	-	-	-	-	0.4	0.4	0.4	0.4	-	50	GPS1BHAC	0.25	0.4					
-	F	-	-	-	-	0.63	0.63	0.63	0.63	-	50	GPS1BHAD	0.4	0.63					
-	F	-	-	-	0.5	1	1	1	1.1	-	50	GPS1BHAE	0.63	1					
-	F	0.25	0.25	0.33	0.75	1.6	1.6	1.6	1.6	-	50	GPS1BHAF	1	1.6					
-	F	0.5	0.5	0.5	1	2.5	2.4	2.2	2.1	-	50	GPS1BHAG	1.6	2.5					
-	F	0.75	0.75	0.75	2	3.7	3.5	3.2	3.4	-	50	GPS1BHAH	2.5	4					
-	F	1	1	1.5	3	4.8	4.6	6	4.8	-	50	GPS1BHAI	4	6.3					
-	F	2	2	3	5	7.8	7.5	9.6	7.6	-	50	GPS1BHAK	6.3	10					
-	F	3	3	3	7.5	11	10.6	9.6	11	-	50	GPS1BHAL	9	13					
-	F	3	3	5	10	11	10.6	15.2	14	-	50	GPS1BHAM	11	16					
-	F	5	5	5	10	17.5	16.7	15.2	14	-	50	GPS1BHAN	14	20					
-	F	5	5	7.5	15	17.5	16.7	22	21	-	50	GPS1BHAP	19	25					
-	F	5	5	7.5	15	17.5	16.7	22	21	-	50	GPS1BHAR	24	32					
-	F	-	-	-	-	0.16	0.16	0.16	0.16	-	50	GPS1BHAA	0.1	0.16					
-	F	-	-	-	-	0.25	0.25	0.25	0.25	-	50	GPS1BHAB	0.16	0.25					
-	F	-	-	-	-	0.4	0.4	0.4	0.4	-	50	GPS1BHAC	0.25	0.4					
-	F	-	-	-	-	0.63	0.63	0.63	0.63	-	50	GPS1BHAD	0.4	0.63					
-	F	-	-	-	0.5	1	1	1	1.1	-	50	GPS1BHAE	0.63	1					
-	F	0.25	0.25	0.33	0.75	1.6	1.6	1.6	1.6	-	50	GPS1BHAF	1	1.6					
-	F	0.5	0.5	0.5	1	2.5	2.4	2.2	2.1	-	50	GPS1BHAG	1.6	2.5					
-	F	0.75	0.75	0.75	2	3.7	3.5	3.2	3.4	-	50	GPS1BHAH	2.5	4					
-	F	1	1	1.5	3	4.8	4.6	6	4.8	-	50	GPS1BHAI	4	6.3					
-	F	2	2	3	5	7.8	7.5	9.6	7.6	-	50	GPS1BHAK	6.3	10					
-	F	3	3	3	7.5	11	10.6	9.6	11	-	50	GPS1BHAL	9	13					
-	F	3	3	5	10	11	10.6	15.2	14	-	50	GPS1BHAM	11	16					
-	F	5	5	5	10	17.5	16.7	15.2	14	-	50	GPS1BHAN	14	20					
-	F	5	5	7.5	15	17.5	16.7	22	21	-	50	GPS1BHAP	19	25					
-	F	5	5	7.5	15	17.5	16.7	22	21	-	50	GPS1BHAR	24	32					

Surion GPS2 Combination with Contactor CL series

Construction Type		Max. Motor HP Rating				Max. Motor FLA				SCCR (kA)		Manual Motor Controller		GE Cat. No. Component List					
240V	480V/277V	200V	208V	230V	460V	200V	208V	230V	460V	240 V	480V/277 V	GE Cat. No.	Motor Current Adjust Range		Contactor	Feed-in Terminals	SC Alarm	Link Module	Base Plate
												Min. (A)	Max. (A)						
-	F	2	2	3	5	7.8	7.5	9.6	7.6	-	50	GPS2BHK	6.3	10	CL04[*] 310M[**]	-	GPAE11LLA	GPF2L04AA	GPF2B2A
-	F	3	3	3	7.5	11	10.6	9.6	11	-	50	GPS2BHL	9	13					
-	F	3	3	5	7.5	11	10.6	15.2	11	-	50	GPS2BHM	11	16					
-	F	5	5	5	10	17.5	16.7	15.2	14	-	50	GPS2BHN	14	20					
-	F	7.5	7.5	7.5	15	25.3	24.2	22	21	-	50	GPS2BHP	19	25					
-	F	10	10	10	20	32.2	30.8	28	27	-	50	GPS2BHR	24	32					
-	F	10	10	10	20	32.2	30.8	28	27	-	50	GPS2BHS	28	40					
-	F	10	10	10	20	32.2	30.8	28	27	-	50	GPS2BHT	35	50					
-	F	10	10	10	20	32.2	30.8	28	27	-	50	GPS2BHU	45	63					
-	F	2	2	3	5	7.8	7.5	9.6	7.6	-	50	GPS2BHK	6.3	10					
-	F	3	3	3	7.5	11	10.6	9.6	11	-	50	GPS2BHL	9	13					
-	F	3	3	5	7.5	11	10.6	15.2	11	-	50	GPS2BHM	11	16					
-	F	5	5	5	10	17.5	16.7	15.2	14	-	50	GPS2BHN	14	20					
-	F	7.5	7.5	7.5	15	25.3	24.2	22	21	-	50	GPS2BHP	19	25					
-	F	10	10	10	20	32.2	30.8	28	27	-	50	GPS2BHR	24	32					
-	F	10	10	10	20	32.2	30.8	28	27	-	50	GPS2BHS	28	40					
-	F	10	10	10	20	32.2	30.8	28	27	-	50	GPS2BHT	35	50					
-	F	10	10	10	20	32.2	30.8	28	27	-	50	GPS2BHU	45	63					
-	F	2	2	3	5	7.8	7.5	9.6	7.6	-	50	GPS2BHK	6.3	10					
-	F	3	3	3	7.5	11	10.6	9.6	11	-	50	GPS2BHL	9	13					
-	F	3	3	5	7.5	11	10.6	15.2	11	-	50	GPS2BHM	11	16					
-	F	5	5	5	10	17.5	16.7	15.2	14	-	50	GPS2BHN	14	20					
-	F	7.5	7.5	7.5	15	25.3	24.2	22	21	-	50	GPS2BHP	19	25					
-	F	10	10	10	20	32.2	30.8	28	27	-	50	GPS2BHR	24	32					
-	F	10	10	10	20	32.2	30.8	28	27	-	50	GPS2BHS	28	40					
-	F	10	10	10	20	32.2	30.8	28	27	-	50	GPS2BHT	35	50					
-	F	10	10	10	20	32.2	30.8	28	27	-	50	GPS2BHU	45	63					
-	F	15	15	15	30	48.3	46.2	42	40	-	50	GPS2BHT	35	50					
-	F	15	15	15	30	48.3	46.2	42	40	-	50	GPS2BHU	45	63					
-	F	2	2	3	5	7.8	7.5	9.6	7.6	-	50	GPS2BHK	6.3	10					
-	F	3	3	3	7.5	11	10.6	9.6	11	-	50	GPS2BHL	9	13					
-	F	3	3	5	7.5	11	10.6	15.2	11	-	50	GPS2BHM	11	16					
-	F	5	5	5	10	17.5	16.7	15.2	14	-	50	GPS2BHN	14	20					
-	F	7.5	7.5	7.5	15	25.3	24.2	22	21	-	50	GPS2BHP	19	25					
-	F	10	10	10	20	32.2	30.8	28	27	-	50	GPS2BHR	24	32					
-	F	10	10	10	20	32.2	30.8	28	27	-	50	GPS2BHS	28	40					
-	F	10	10	10	20	32.2	30.8	28	27	-	50	GPS2BHT	35	50					
-	F	10	10	10	20	32.2	30.8	28	27	-	50	GPS2BHU	45	63					
-	F	2	2	3	5	7.8	7.5	9.6	7.6	-	50	GPS2BHK	6.3	10					
-	F	3	3	3	7.5	11	10.6	9.6	11	-	50	GPS2BHL	9	13					
-	F	3	3	5	7.5	11	10.6	15.2	11	-	50	GPS2BHM	11	16					
-	F	5	5	5	10	17.5	16.7	15.2	14	-	50	GPS2BHN	14	20					
-	F	7.5	7.5	7.5	15	25.3	24.2	22	21	-	50	GPS2BHP	19	25					
-	F	10	10	10	20	32.2	30.8	28	27	-	50	GPS2BHR	24	32					
-	F	10	10	10	20	32.2	30.8	28	27	-	50	GPS2BHS	28	40					
-	F	10	10	10	20	32.2	30.8	28	27	-	50	GPS2BHT	35	50					
-	F	10	10	10	20	32.2	30.8	28	27	-	50	GPS2BHU	45	63					





Combination Motor Controllers

Surion GPS1 Combination with Contactor Effcor series

Construction Type	Max. Motor HP Rating				Max. Motor FLA				SCCR (kA)		Manual Motor Controller		GE Cat. No. Component List							
	240V	480V/277V	200V	208V	230V	460V	200V	208V	230V	460V	240 V	480Y/277 V	GE Cat. No.	Motor Current Adjust Range	Min. (A)	Max. (A)	Contactor	Feed-in Terminals	SC Alarm	Link Module
F	F	-	-	-	-	0.16	0.16	0.16	0.16	100	65	GPS1BHAA	0.1	0.16	EC09[*] 311B[**]	GPAPT1E	GPAE11LLA	ECML1AL25	ECBP45	
F	F	-	-	-	-	0.25	0.25	0.25	0.25	100	65	GPS1BHAB	0.16	0.25						
F	F	-	-	-	-	0.4	0.4	0.4	0.4	100	65	GPS1BHAC	0.25	0.4						
F	F	-	-	-	-	0.63	0.63	0.63	0.63	100	65	GPS1BHAD	0.4	0.63						
F	F	-	-	-	0.5	1	1	1	1.1	100	65	GPS1BHA E	0.63	1						
F	F	0.25	0.25	0.33	0.75	1.6	1.6	1.6	1.6	100	65	GPS1BHAF	1	1.6						
F	F	0.5	0.5	0.5	1	2.5	2.4	2.2	2.1	100	65	GPS1BHAG	1.6	2.5						
F	F	0.75	0.75	0.75	2	3.7	3.5	3.2	3.4	100	65	GPS1BHAH	2.5	4						
F	F	1	1	1.5	3	4.8	4.6	4.6	6	4.8	100	65	GPS1BHAJ	4						6.3
F	F	2	2	3	5	7.8	7.5	9.6	7.6	100	65	GPS1BHAK	6.3	10						
F	F	3	3	3	5	11	10.6	9.6	7.6	100	65	GPS1BHAL	9	13						
F	F	3	3	3	5	11	10.6	9.6	7.6	65	65	GPS1BHAM	11	16						
F	F	3	3	3	5	11	10.6	9.6	7.6	65	65	GPS1BHAN	14	20						
F	F	3	3	3	5	11	10.6	9.6	7.6	65	65	GPS1BHAP	19	25						
F	F	3	3	3	5	11	10.6	9.6	7.6	65	65	GPS1BHAR	24	32						
F	F	-	-	-	-	0.16	0.16	0.16	0.16	100	65	GPS1BHAA	0.1	0.16						
F	F	-	-	-	-	0.25	0.25	0.25	0.25	100	65	GPS1BHAB	0.16	0.25						
F	F	-	-	-	-	0.4	0.4	0.4	0.4	100	65	GPS1BHAC	0.25	0.4						
F	F	-	-	-	-	0.63	0.63	0.63	0.63	100	65	GPS1BHAD	0.4	0.63						
F	F	-	-	-	0.5	1	1	1	1.1	100	65	GPS1BHA E	0.63	1						
F	F	0.25	0.25	0.33	0.75	1.6	1.6	1.6	1.6	100	65	GPS1BHAF	1	1.6						
F	F	0.5	0.5	0.5	1	2.5	2.4	2.2	2.1	100	65	GPS1BHAG	1.6	2.5						
F	F	0.75	0.75	0.75	2	3.7	3.5	3.2	3.4	100	65	GPS1BHAH	2.5	4						
F	F	1	1	1.5	3	4.8	4.6	4.6	6	4.8	100	65	GPS1BHAJ	4	6.3					
F	F	2	2	3	5	7.8	7.5	9.6	7.6	100	65	GPS1BHAK	6.3	10						
F	F	3	3	3	5	11	10.6	9.6	7.6	100	65	GPS1BHAL	9	13						
F	F	3	3	3	5	11	10.6	9.6	7.6	65	65	GPS1BHAM	11	16						
F	F	3	3	3	5	11	10.6	9.6	7.6	65	65	GPS1BHAN	14	20						
F	F	3	3	3	5	11	10.6	9.6	7.6	65	65	GPS1BHAP	19	25						
F	F	3	3	3	5	11	10.6	9.6	7.6	65	65	GPS1BHAR	24	32						
F	F	-	-	-	-	0.16	0.16	0.16	0.16	100	65	GPS1BHAA	0.1	0.16						
F	F	-	-	-	-	0.25	0.25	0.25	0.25	100	65	GPS1BHAB	0.16	0.25						
F	F	-	-	-	-	0.4	0.4	0.4	0.4	100	65	GPS1BHAC	0.25	0.4						
F	F	-	-	-	-	0.63	0.63	0.63	0.63	100	65	GPS1BHAD	0.4	0.63						
F	F	-	-	-	0.5	1	1	1	1.1	100	65	GPS1BHA E	0.63	1						
F	F	0.25	0.25	0.33	0.75	1.6	1.6	1.6	1.6	100	65	GPS1BHAF	1	1.6						
F	F	0.5	0.5	0.5	1	2.5	2.4	2.2	2.1	100	65	GPS1BHAG	1.6	2.5						
F	F	0.75	0.75	0.75	2	3.7	3.5	3.2	3.4	100	65	GPS1BHAH	2.5	4						
F	F	1	1	1.5	3	4.8	4.6	4.6	6	4.8	100	65	GPS1BHAJ	4	6.3					
F	F	2	2	3	5	7.8	7.5	9.6	7.6	100	65	GPS1BHAK	6.3	10						
F	F	3	3	3	5	11	10.6	9.6	7.6	100	65	GPS1BHAL	9	13						
F	F	3	3	3	5	11	10.6	15.2	14	65	65	GPS1BHAM	11	16						
F	F	5	5	5	10	17.5	16.7	15.2	14	65	65	GPS1BHAN	14	20						
F	F	5	5	5	10	17.5	16.7	15.2	14	65	65	GPS1BHAP	19	25						
F	F	5	5	5	10	17.5	16.7	15.2	14	65	65	GPS1BHAR	24	32						
F	F	-	-	-	-	0.16	0.16	0.16	0.16	100	65	GPS1BHAA	0.1	0.16						
F	F	-	-	-	-	0.25	0.25	0.25	0.25	100	65	GPS1BHAB	0.16	0.25						
F	F	-	-	-	-	0.4	0.4	0.4	0.4	100	65	GPS1BHAC	0.25	0.4						
F	F	-	-	-	-	0.63	0.63	0.63	0.63	100	65	GPS1BHAD	0.4	0.63						
F	F	-	-	-	0.5	1	1	1	1.1	100	65	GPS1BHA E	0.63	1						
F	F	0.25	0.25	0.33	0.75	1.6	1.6	1.6	1.6	100	65	GPS1BHAF	1	1.6						
F	F	0.5	0.5	0.5	1	2.5	2.4	2.2	2.1	100	65	GPS1BHAG	1.6	2.5						
F	F	0.75	0.75	0.75	2	3.7	3.5	3.2	3.4	100	65	GPS1BHAH	2.5	4						
F	F	1	1	1.5	3	4.8	4.6	4.6	6	4.8	100	65	GPS1BHAJ	4	6.3					
F	F	2	2	3	5	7.8	7.5	9.6	7.6	100	65	GPS1BHAK	6.3	10						
F	F	3	3	3	5	11	10.6	9.6	7.6	100	65	GPS1BHAL	9	13						
F	F	3	3	3	5	10	11	10.6	15.2	14	65	65	GPS1BHAM	11	16					
F	F	5	5	5	10	17.5	16.7	15.2	14	65	65	GPS1BHAN	14	20						
F	F	7.5	7.5	7.5	15	25.3	24.2	22	21	65	65	GPS1BHAP	19	25						
F	F	7.5	7.5	7.5	15	25.3	24.2	22	21	65	65	GPS1BHAR	24	32						
F	F	-	-	-	-	0.16	0.16	0.16	0.16	100	65	GPS1BHAA	0.1	0.16						
F	F	-	-	-	-	0.25	0.25	0.25	0.25	100	65	GPS1BHAB	0.16	0.25						
F	F	-	-	-	-	0.4	0.4	0.4	0.4	100	65	GPS1BHAC	0.25	0.4						
F	F	-	-	-	-	0.63	0.63	0.63	0.63	100	65	GPS1BHAD	0.4	0.63						
F	F	-	-	-	0.5	1	1	1	1.1	100	65	GPS1BHA E	0.63	1						
F	F	0.25	0.25	0.33	0.75	1.6	1.6	1.6	1.6	100	65	GPS1BHAF	1	1.6						
F	F	0.5	0.5	0.5	1	2.5	2.4	2.2	2.1	100	65	GPS1BHAG	1.6	2.5						
F	F	0.75	0.75	0.75	2	3.7	3.5	3.2	3.4	100	65	GPS1BHAH	2.5	4						
F	F	1	1	1.5	3	4.8	4.6	4.6	6	4.8	100	65	GPS1BHAJ	4	6.3					
F	F	2	2	3	5	7.8	7.5	9.6	7.6	100	65	GPS1BHAK	6.3	10						
F	F	3	3	3	5	11	10.6	9.6	7.6	100	65	GPS1BHAL	9	13						
F	F	3	3	3	5	10	11	10.6	15.2	14	65	65	GPS1BHAM	11	16					
F	F	5	5	5	10	17.5	16.7	15.2	14	65	65	GPS1BHAN	14	20						
F	F	7.5	7.5	7.5	15	25.3	24.2	22	21	65	65	GPS1BHAP	19	25						
F	F	10	10	10	20	32.2	30.8	28	27	65	65	GPS1BHAR	24	32						

UL Applications

Intro

A

B

C

D

E

F

G

H

I

X



Combination Motor Controllers

Surion GPS2 Combination with Contactor Effcor series

Construction Type	Max. Motor HP Rating				Max. Motor FLA				SCCR (kA)		Manual Motor Controller Motor Current Adjust Range		GE Cat. No. Component List						
	240V	480V/277V	200V	208V	230V	460V	200V	208V	230V	460V	240 V	480V/277 V	GE Cat. No.	Min. (A)	Max. (A)	Contactor	Feed-in Terminals	SC Alarm	Link Module
F	F	2	2	3	5	7.8	7.5	9.6	7.6	100	50	GPS2BHK	6.3	10	EC32[*] 300B[**]	-	GPAE11LLA	ECM1AL40	ECBP55
F	F	3	3	3	7.5	11	10.6	9.6	11	100	50	GPS2BHL	9	13					
F	F	3	3	5	7.5	11	10.6	15.2	11	100	50	GPS2BHM	11	16					
F	F	5	5	5	10	17.5	16.7	15.2	14	100	50	GPS2BHN	14	20					
F	F	7.5	7.5	7.5	15	25.3	24.2	22	21	100	50	GPS2BHP	19	25					
F	F	10	10	10	20	32.2	30.8	28	27	100	50	GPS2BHR	24	32					
F	F	10	10	10	20	32.2	30.8	28	27	100	50	GPS2BHS	28	40					
F	F	10	10	10	20	32.2	30.8	28	27	100	50	GPS2BHT	35	50					
F	F	10	10	10	20	32.2	30.8	28	27	100	50	GPS2BHU	45	63					
F	F	2	2	3	5	7.8	7.5	9.6	7.6	100	50	GPS2BHK	6.3	10					
F	F	3	3	3	7.5	11	10.6	9.6	11	100	50	GPS2BHL	9	13					
F	F	3	3	5	7.5	11	10.6	15.2	11	100	50	GPS2BHM	11	16					
F	F	5	5	5	10	17.5	16.7	15.2	14	100	50	GPS2BHN	14	20					
F	F	7.5	7.5	7.5	15	25.3	24.2	22	21	100	50	GPS2BHP	19	25					
F	F	10	10	10	20	32.2	30.8	28	27	100	50	GPS2BHR	24	32					
F	F	10	10	10	25	32.2	30.8	28	34	100	50	GPS2BHS	28	40					
F	F	10	10	10	25	32.2	30.8	28	34	100	50	GPS2BHT	35	50					
F	F	10	10	10	25	32.2	30.8	28	34	100	50	GPS2BHU	45	63					
F	F	2	2	3	5	7.8	7.5	9.6	7.6	100	65	GPS2BHK	6.3	10					
F	F	3	3	3	7.5	11	10.6	9.6	11	100	65	GPS2BHL	9	13					
F	F	3	3	5	7.5	11	10.6	15.2	11	100	65	GPS2BHM	11	16					
F	F	5	5	5	10	17.5	16.7	15.2	14	100	65	GPS2BHN	14	20					
F	F	7.5	7.5	7.5	15	25.3	24.2	22	21	100	65	GPS2BHP	19	25					
F	F	10	10	10	20	32.2	30.8	28	27	100	65	GPS2BHR	24	32					
F	F	10	10	10	25	32.2	30.8	28	34	100	65	GPS2BHS	28	40					
F	F	10	10	10	25	32.2	30.8	28	34	100	65	GPS2BHT	35	50					
F	F	10	10	10	25	32.2	30.8	28	34	100	65	GPS2BHU	45	63					
F	F	2	2	3	5	7.8	7.5	9.6	7.6	100	65	GPS2BHK	6.3	10					
F	F	3	3	3	7.5	11	10.6	9.6	11	100	65	GPS2BHL	9	13					
F	F	3	3	5	7.5	11	10.6	15.2	11	100	65	GPS2BHM	11	16					
F	F	5	5	5	10	17.5	16.7	15.2	14	100	65	GPS2BHN	14	20					
F	F	7.5	7.5	7.5	15	25.3	24.2	22	21	100	65	GPS2BHP	19	25					
F	F	10	10	10	20	32.2	30.8	28	27	100	65	GPS2BHR	24	32					
F	F	10	10	10	25	32.2	30.8	28	34	100	65	GPS2BHS	28	40					
F	F	15	15	15	30	48.3	46.2	42	40	100	65	GPS2BHT	35	50					
F	F	15	15	15	30	48.3	46.2	42	40	100	65	GPS2BHU	45	63					
F	F	2	2	3	5	7.8	7.5	9.6	7.6	100	65	GPS2BHK	6.3	10					
F	F	3	3	3	7.5	11	10.6	9.6	11	100	65	GPS2BHL	9	13					
F	F	3	3	5	7.5	11	10.6	15.2	11	100	65	GPS2BHM	11	16					
F	F	5	5	5	10	17.5	16.7	15.2	14	100	65	GPS2BHN	14	20					
F	F	7.5	7.5	7.5	15	25.3	24.2	22	21	100	65	GPS2BHP	19	25					
F	F	10	10	10	20	32.2	30.8	28	27	100	65	GPS2BHR	24	32					
F	F	10	10	10	25	32.2	30.8	28	34	100	65	GPS2BHS	28	40					
F	F	15	15	15	30	48.3	46.2	42	40	100	65	GPS2BHT	35	50					
F	F	15	15	20	40	48.3	46.2	54	52	100	65	GPS2BHU	45	63					

UL Applications

Intro

A

B

C

D

E

F

G

H

I

X



Product Index Alpha Numeric - UL Reference

Catalog Number	UL Reference		cUL/CSA Cert
	File E	Type	
BCLF01	103664	L	cUL
BCLF01G	103664	L	cUL
BCLF10	103664	L	cUL
BCLF10G	103664	L	cUL
BCLL11	103664	L	cUL
BCLL11	103664	L	cUL
BCLL20	103664	L	cUL
BCLL20	103664	L	cUL
BELA	103664	L	cUL
BELA	103664	L	cUL
BELA02	103664	L	cUL
BELA02	103664	L	cUL
BRLL02	103664	L	cUL
BRLL11	103664	L	cUL
BRLL20	103664	L	cUL
BTLF30C	103664	L	cUL
BTLF30D	103664	L	cUL
BTLF60C	103664	L	cUL
BTLF60D	103664	L	cUL
BTRF30C	103664	L	cUL
BTRF30D	103664	L	cUL
BTRF60C	103664	L	cUL
BTRF60D	103664	L	cUL
CK08BA411J	76233	L	cUL
CK08BA411N	76233	L	cUL
CK08BA411U	76233	L	cUL
CK08BA411Y	76233	L	cUL
CK08BE411W100-250	76233	L	cUL
CK08BE411W24-60	76233	L	cUL
CK08BE411W250-500	76233	L	cUL
CK08BE411W48-130	76233	L	cUL
CK08CA311J	76233	L	cUL
CK08CA311N	76233	L	cUL
CK08CA311U	76233	L	cUL
CK08CA311Y	76233	L	cUL
CK08CE311W100-250	76233	L	cUL
CK08CE311W24-60	76233	L	cUL
CK08CE311W250-500	76233	L	cUL
CK08CE311W48-130	76233	L	cUL
CK09BE311W100-250	76233	L	cUL
CK09BE311W24-60	76233	L	cUL
CK09BE311W250-500	76233	L	cUL
CK09BE311W48-130	76233	L	cUL
CK09BE411W100-250	76233	L	cUL
CK09BE411W24-60	76233	L	cUL
CK09BE411W250-500	76233	L	cUL
CK09BE411W48-130	76233	L	cUL
CK10CE311W100-250	76233	L	cUL
CK10CE311W24-60	76233	L	cUL
CK10CE311W250-500	76233	L	cUL
CK10CE311W48-130	76233	L	cUL
CK11CE311W100-250	76233	L	cUL
CK11CE311W24-60	76233	L	cUL
CK11CE311W250-500	76233	L	cUL
CK11CE311W48-130	76233	L	cUL
CK12BE311W100-250	76233	L	cUL
CK12BE311W24-60	76233	L	cUL
CK12BE311W250-500	76233	L	cUL
CK12BE311W48-130	76233	L	cUL
CK12BE411W100-250	76233	L	cUL
CK12BE411W24-60	76233	L	cUL
CK12BE411W250-500	76233	L	cUL
CK12BE411W48-130	76233	L	cUL
CK75CA311J	76233	L	cUL
CK75CA311N	76233	L	cUL
CK75CA311U	76233	L	cUL
CK75CA311Y	76233	L	cUL
CK75CE311W100-250	76233	L	cUL
CK75CE311W24-60	76233	L	cUL
CK75CE311W250-500	76233	L	cUL
CK75CE311W48-130	76233	L	cUL
CK95BE311W100-250	76233	L	cUL
CK95BE311W24-60	76233	L	cUL
CK95BE311W250-500	76233	L	cUL
CK95BE311W48-130	76233	L	cUL
CK95BE411W100-250	76233	L	cUL
CK95BE411W24-60	76233	L	cUL
CK95BE411W250-500	76233	L	cUL
CK95BE411W48-130	76233	L	cUL
CL00A301T*	76233	L	cUL

Catalog Number	UL Reference		cUL/CSA Cert
	File E	Type	
CL00A310T*	76233	L	cUL
CL00D301T*	76233	L	cUL
CL00D310T*	76233	L	cUL
CL01A301T*	76233	L	cUL
CL01A310T*	76233	L	cUL
CL01A400T*	76233	L	cUL
CL01AB00T*	76233	L	cUL
CL01D301T*	76233	L	cUL
CL01D310T*	76233	L	cUL
CL01D400T*	76233	L	cUL
CL01DB00T*	76233	L	cUL
CL02A301T*	76233	L	cUL
CL02A310T*	76233	L	cUL
CL02A400T*	76233	L	cUL
CL02A400T*	76233	L	cUL
CL02AA00T*	76233	L	cUL
CL02AB00T*	76233	L	cUL
CL02D301T*	76233	L	cUL
CL02D310T*	76233	L	cUL
CL02DA00TD	76233	L	cUL
CL02DB00T*	76233	L	cUL
CL03A300T*	76233	L	cUL
CL03A400M*	76233	L	cUL
CL03AB00M*	76233	L	cUL
CL03D300T*	76233	L	cUL
CL03D400M*	76233	L	cUL
CL03DB00M*	76233	L	cUL
CL04A301M*	76233	L	cUL
CL04A310M*	76233	L	cUL
CL04A400M*	76233	L	cUL
CL04AB00M*	76233	L	cUL
CL04D301M*	76233	L	cUL
CL04D310M*	76233	L	cUL
CL04D400M*	76233	L	cUL
CL04DB00M*	76233	L	cUL
CL05A300M*	76233	L	cUL
CL05A400M*	76233	L	cUL
CL05AB00M*	76233	L	cUL
CL05D300M*	76233	L	cUL
CL05D400M*	76233	L	cUL
CL05DB00M*	76233	L	cUL
CL05E400M*	76233	L	cUL
CL05EB00M*	76233	L	cUL
CL07A300M*	76233	L	cUL
CL07A400M*	76233	L	cUL
CL07AB00M*	76233	L	cUL
CL07D300M*	76233	L	cUL
CL07D400M*	76233	L	cUL
CL07DB00M*	76233	L	cUL
CL07E300M*	76233	L	cUL
CL07E400M*	76233	L	cUL
CL07EB00M*	76233	L	cUL
CL08A300M*	76233	L	cUL
CL08AB00M*	76233	L	cUL
CL08D300M*	76233	L	cUL
CL08DB00M*	76233	L	cUL
CL08E300M*	76233	L	cUL
CL08EB00M*	76233	L	cUL
CL09A300M*	76233	L	cUL
CL09A400M*	76233	L	cUL
CL09D300M*	76233	L	cUL
CL09D400M*	76233	L	cUL
CL09E300M*	76233	L	cUL
CL09E400M*	76233	L	cUL
CL10A300M*	76233	L	cUL
CL10D300M*	76233	L	cUL
CL10E300M*	76233	L	cUL
CLXC41			
CLXC51			
EA07A301I024	76233	L	cUL
EA07A301I230	76233	L	cUL
EA07A301S024	76233	L	cUL
EA07A301S048	76233	L	cUL
EA07A301S110	76233	L	cUL
EA07A301S230	76233	L	cUL
EA07A310I024	76233	L	cUL
EA07A310I230	76233	L	cUL
EA07A310S024	76233	L	cUL
EA07A310S048	76233	L	cUL
EA07A310S110	76233	L	cUL
EA07A310S110	76233	L	cUL

Catalog Number	UL Reference		cUL/CSA Cert
	File E	Type	
EA07A310S230	76233	L	cUL
EA07D301I024	76233	L	cUL
EA07D301I110	76233	L	cUL
EA07D301S024	76233	L	cUL
EA07D301S110	76233	L	cUL
EA07D310I024	76233	L	cUL
EA07D310I110	76233	L	cUL
EA07D310S024	76233	L	cUL
EA07D310S110	76233	L	cUL
EC09A311B*	331054	L	cUL
EC09D311B*	331054	L	cUL
EC09E311B*	331054	L	cUL
EC12A311B*	331054	L	cUL
EC12A400B*	331054	L	cUL
EC12AB00B*	331054	L	cUL
EC12D311B*	331054	L	cUL
EC12D400B*	331054	L	cUL
EC12DB00B*	331054	L	cUL
EC12E311B*	331054	L	cUL
EC12E400B*	331054	L	cUL
EC12EB00B*	331054	L	cUL
EC18A311B*	331054	L	cUL
EC18A400B*	331054	L	cUL
EC18AB00B*	331054	L	cUL
EC18D311B*	331054	L	cUL
EC18D400B*	331054	L	cUL
EC18DB00B*	331054	L	cUL
EC18E311B*	331054	L	cUL
EC18E400B*	331054	L	cUL
EC18EB00B*	331054	L	cUL
EC25A311B*	331054	L	cUL
EC25A400B*	331054	L	cUL
EC25AB00B*	331054	L	cUL
EC25D311B*	331054	L	cUL
EC25D400B*	331054	L	cUL
EC25DB00B*	331054	L	cUL
EC25E311B*	331054	L	cUL
EC25E400B*	331054	L	cUL
EC25EB00B*	331054	L	cUL
EC32A300B*	331054	L	cUL
EC32A400B*	331054	L	cUL
EC32AB00B*	331054	L	cUL
EC32D300B*	331054	L	cUL
EC32D400B*	331054	L	cUL
EC32DB00B*	331054	L	cUL
EC32E300B*	331054	L	cUL
EC32E400B*	331054	L	cUL
EC32EB00B*	331054	L	cUL
EC40A300B*	103664	L	cUL
EC40D300B*	103664	L	cUL
EC40E300B*	103664	L	cUL
ECACA400B*	103664	L	cUL
ECACA404B*	103664	L	cUL
ECACA413B*	103664	L	cUL
ECACA422B*	103664	L	cUL
ECACA431B*	103664	L	cUL
ECACE400B*	103664	L	cUL
ECACE404B*	103664	L	cUL
ECACE413B*	103664	L	cUL
ECACE422B*	103664	L	cUL
ECACE431B*	103664	L	cUL
ECBP45	211286	L	cUL
ECBP55	211286	L	cUL
ECFA202S	103664	L	cUL
ECFA211S	103664	L	cUL
ECFA220S	103664	L	cUL
ECFA404S	103664	L	cUL
ECFA413S	103664	L	cUL
ECFA422S	103664	L	cUL
ECFA422SE	103664	L	cUL
ECFA431S	103664	L	cUL
ECFA440S	103664	L	cUL
ECKS1RV	211286	L	cUL
ECKS2RV	211286	L	cUL
ECLA202S	103664	L	cUL
ECLA211S	103664	L	cUL
ECLA220S	103664	L	cUL
ECM1AL25	103664	L	cUL
ECM1AL32	103664	L	cUL
ECM2AL40	103664	L	cUL



Product Index Alpha Numeric - UL Reference

Catalog Number	UL Reference		cUL/CSA Cert
	File E	Type	
PRC4M40AGL	198336	R	cUL/CSA
PRC4M40AJL	198336	R	cUL/CSA
PRC4M40ANL	198336	R	cUL/CSA
PRC4M40CBL	198336	R	cUL/CSA
PRC4M40CDL	198336	R	cUL/CSA
PRC4M40CGL	198336	R	cUL/CSA
PRC4M40CJL	198336	R	cUL/CSA
PRC4M40CKL	198336	R	cUL/CSA
PRC4M40CML	198336	R	cUL/CSA
PRC4M40DCBL	198336	R	cUL/CSA
PRC4M40DCDL	198336	R	cUL/CSA
PRC4M40DCGL	198336	R	cUL/CSA
PRC4M40DCJL	198336	R	cUL/CSA
PRC4M40DCKL	198336	R	cUL/CSA
PRC4M40DCML	198336	R	cUL/CSA
PRCG-ES15*	223190	R	cUL/CSA
PRCGZT80	223190	R	cUL/CSA
PRCT1AD			
PRCT1AJ			
PRCT1AN			
PRCT1CB			
PRCT1CD			
PRCT1CJ			
PRCT2AD			
PRCT2AJ			
PRCT2AN			
PRCT2CB			
PRCT2CD			
PRCT2CJ			
PRCZ11	198336	R	cUL/CSA
PRCZ8	198336	R	cUL/CSA
RE1D	103664	L	cUL
RE1H	103664	L	cUL
RE1K	103664	L	cUL
RE1M	103664	L	cUL
RE1S	103664	L	cUL
RE1W	103664	L	cUL
RE1XP	103664	L	cUL
RE2H	103664	L	cUL
RE2M	103664	L	cUL
RE2XP	103664	L	cUL
RE3E	103664	L	cUL
RETC	103664	L	cUL
RL4RA004R*	103664	L	cUL
RL4RA004T*	103664	L	cUL

Catalog Number	UL Reference		cUL/CSA Cert
	File E	Type	
RL4RA022G*	103664	L	cUL
RL4RA022R*	103664	L	cUL
RL4RA022T*	103664	L	cUL
RL4RA031R*	103664	L	cUL
RL4RA031T*	103664	L	cUL
RL4RA040R*	103664	L	cUL
RL4RA040T*	103664	L	cUL
RL4RD004R*	103664	L	cUL
RL4RD004T*	103664	L	cUL
RL4RD022G*	103664	L	cUL
RL4RD022R*	103664	L	cUL
RL4RD022T*	103664	L	cUL
RL4RD031R*	103664	L	cUL
RL4RD031T*	103664	L	cUL
RL4RD040R*	103664	L	cUL
RL4RD040T*	103664	L	cUL
RMLF*	103664	L	cUL
RT1B	103664	L	cUL
RT1C	103664	L	cUL
RT1D	103664	L	cUL
RT1F	103664	L	cUL
RT1G	103664	L	cUL
RT1H	103664	L	cUL
RT1J	103664	L	cUL
RT1K	103664	L	cUL
RT1L	103664	L	cUL
RT1M	103664	L	cUL
RT1N	103664	L	cUL
RT1P	103664	L	cUL
RT1S	103664	L	cUL
RT1T	103664	L	cUL
RT1U	103664	L	cUL
RT1V	103664	L	cUL
RT1W	103664	L	cUL
RT2A	103664	L	cUL
RT2B	103664	L	cUL
RT2C	103664	L	cUL
RT2D	103664	L	cUL
RT2E	103664	L	cUL
RT2G	103664	L	cUL
RT2H	103664	L	cUL
RT2J	103664	L	cUL
RT2L	103664	L	cUL
RT2M	103664	L	cUL

Catalog Number	UL Reference		cUL/CSA Cert
	File E	Type	
RT2XP	103664	L	cUL
RT32C	103664	L	cUL
RT32D	103664	L	cUL
RT32E	103664	L	cUL
RT32F	103664	L	cUL
RT3B	103664	L	cUL
RT3C	103664	L	cUL
RT3D	103664	L	cUL
RT3E	103664	L	cUL
RT3F	103664	L	cUL
RT4LA	103664	L	cUL
RT4LB	103664	L	cUL
RT4LC	103664	L	cUL
RT4LD	103664	L	cUL
RT4LE	103664	L	cUL
RT4LF	103664	L	cUL
RT4LG	103664	L	cUL
RT4LH	103664	L	cUL
RT4LJ	103664	L	cUL
RT4LK	103664	L	cUL
RT4LL	103664	L	cUL
RT4LM	103664	L	cUL
RT4LN	103664	L	cUL
RT4LP	103664	L	cUL
RT4LR	103664	L	cUL
RT4N	103664	L	cUL
RT4P	103664	L	cUL
RT4R	103664	L	cUL
RT5A	103664	L	cUL
RT5B	103664	L	cUL
RT5C	103664	L	cUL
RT5D	103664	L	cUL
RT5E	103664	L	cUL
RT5LA	103664	L	cUL
RT5LB	103664	L	cUL
RT5LC	103664	L	cUL
RT5LD	103664	L	cUL
RT5LE	103664	L	cUL
RT6A	103664	L	cUL
RTXP	103664	L	cUL
RTXRR*	103664	L	cUL
SFVB8	211286	L	cUL
WKLI02P	103664	L	cUL
WKMIU	103664	L	cUL

Intro

A

B

C

D

E

F

G

H

I

X



CLN Contactors

Overview

CLN contactors are available in NEMA Sizes 00 to 4 and they are used for full-voltage starting, stopping and reversing electric motors and switching a variety of applications such as heating loads, capacitors, lighting and transformers.

The long-life cycle, flexibility and ease of use make CLN contactors ideal for industrial and commercial applications that include marine, oil & gas, general industry, mining, hospitals and retail.

A wide array of overload relays and accessories provides greater design versatility, easy installation, flexible configurations, lower inventory requirements, and efficient use of panel space.

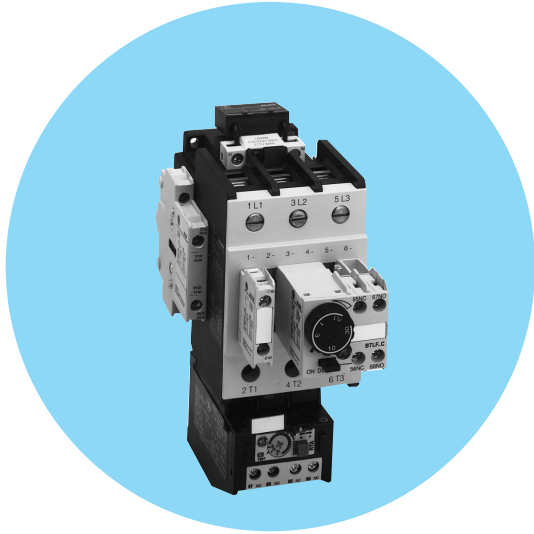

Standards

NFPA 70E
 National Electrical Code (NEC)
 NEMA ICS 2 - Industrial Control Systems
 UL 508

Approvals/Marking



Contactors: CLN Series



NEMA Size	CLN Contactors	Continuous Current (A)	Controls Voltage	Catalog No.	Reference No.	Main Poles	Auxiliary Contacts Built-in	
							CLNAA310AT1	NC
00	CLNA	9	24V 60Hz	CLNAA310AT1	248122	3	1	0
			120V 60Hz	CLNAA310ATJ	248123			
			240V 60Hz	CLNAA310ATS	248124			
			480V 60Hz	CLNAA310ATU	248125			
0	CLNB	18	24V 60Hz	CLNBA310AT1	248126	3	1	0
			120V 60Hz	CLNBA310ATJ	248127			
			240V 60Hz	CLNBA310ATS	248128			
			480V 60Hz	CLNBA310ATU	248129			
1	CLNC	27	24V 60Hz	CLNCA310AM1	248130	3	1	0
			120V 60Hz	CLNCA310AMJ	248131			
			240V 60Hz	CLNCA310AMS	248132			
			480V 60Hz	CLNCA310AMU	248133			
2	CLND	45	24V 60Hz	CLNDA310AM1	248134	3	1	0
			120V 60Hz	CLNDA310AMJ	248135			
			240V 60Hz	CLNDA310AMS	248136			
			480V 60Hz	CLNDA310AMU	248137			
3	CLNE	90	24V 60Hz	CLNEA310AM1	248138	3	1	0
			120V 60Hz	CLNEA310AMJ	248139			
			240V 60Hz	CLNEA310AMS	248140			
			480V 60Hz	CLNEA310AMU	248141			
4	CLNF	135	24-60V 60Hz-DC	CLNFE311ARD	248142	3	1	1
			48-130V 60Hz-DC	CLNFE311ARJ	248143			
			100-250V 60Hz-DC	CLNFE311ARN	248144			
			250-500V 60Hz-DC	CLNFE311ARY	248145			

Spare coils	Contactor	24V 60Hz	48V 60Hz	110-120 60Hz	208V 60Hz	230V 60Hz	277V 60Hz	480V 60Hz	600V 60Hz
	CLNA	LB1A1	LB1A9	LB1AJ	LB1AL	LB1A6	LB1AN	LB1AU	LB1AY
	CLNB	LB3A1	LB3A9	LB3AJ	LB3AL	LB3A6	LB3AN	LB3AU	LB3AY
	CLNC	LB3A1	LB3A9	LB3AJ	LB3AL	LB3A6	LB3AN	LB3AU	LB3AY
	CLND	LB4A1	LB4A9	LB4AJ	LB4AL	LB4A6	LB4AN	LB4AU	LB4AY
	CLNE								

Contactor	24-48V (50-60Hz or DC)	60-130V (50-60Hz or DC)	100-250V (50-60Hz/DC)	250-500V (50-60Hz/DC)
CLNF	KKIT4E24-60	KKIT4E48-130	KKIT4E100-250	KKIT4E250-500

Lugs Kit for CLNF



Contactor	Catalog Number
CLNF	CKX03

Frontal Accessories to use with CLNA, CLNB, CLNC and CLNE



Frontal Auxiliary Blocks: Individual front-mount auxiliary to clip onto front face of the contactor. Contact Rating: A600, Q600

Instantaneous

Number of Contacts	Contacts				Catalog No.	Reference No.
Terminal: screw						
1	1	0	0	0	BCLF10	104700
1	0	1	0	0	BCLF01	104701
1	0	0	1	0	BCLF10G	104702
1	0	0	0	1	BCLF01G	104703

Lateral Accessories to use with CLNA, CLNB, CLNC, CLNE and CLNF



Lateral Auxiliary Blocks: Individual front-mount auxiliary to clip onto front face of the contactor. Contact Rating: A600, Q600

Instantaneous

Number of Contacts	Contacts				Catalog No.	Reference No.
Terminal: screw						
2	2	0	0	0	BCLL20	104706
2	1	1	0	0	BCLL11	104707



Lateral Mechanical and Cross Electrical Interlock: Mechanical interlocks, used for horizontal interlocking of two contactors mounted side-by-side, prevent the closing of one contactor if the other remains closed. BEL02A includes two built-in NC contacts. Contact Rating: A600, Q600.

For use with CLNA, CLNB, CLNC and CLNE

Number of Contacts	Contacts				Catalog No.	Reference No.
Mechanical / electrical						
2	0	2	-	-	BELA02	104724

Horizontal mechanical interlock for use with CLNF



Catalog No.	Reference No.
BEKH	104763

Notes: For cross electrical interlocking, it is required to use a BCLL1 for each contactor. CLNF has already 1 BCLL11 built-in.

Pole Terminal Protection

To use with	Catalog No.	Reference No.
CLNF	PTPCK75	103747

Surge Suppressor

For suppression of disturbances in circuit voltage occurring upon opening of the contactor. Mounts directly on the top of the coil.



RC Circuit protection: Solution for AC operated contactors, reducing coil oscillation frequency and overvoltage peaks.

Varistor: Solution for AC and DC operated contactors, reduce overvoltage peak with low steady state consumption, but not oscillation frequency. This block is recommended for peak mitigation (not complete suppression as diode) and circuit surge protection. CLNF contactors already have a built-in suppressor and varistor.

RC Suppressor for CLNA, CLNB, CLNC

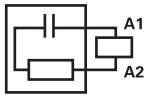

Type	Control Circuit	Ue	Catalog No.	Reference No.
R/C	AC	12V ... 48V	BSLR2G	104713
R/C	AC	50V ... 127V	BSLR2K	104714
R/C	AC	130V ... 250V	BSLR2R	104715

RC Suppressor for CLND and CLNE

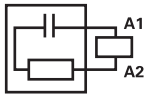

Type	Control Circuit	Ue	Catalog No.	Reference No.
R/C	AC	12V ... 48V	BSLR3G	104716
R/C	AC	50V ... 127V	BSLR3K	104717
R/C	AC	130V ... 250V	BSLR3R	104718

Varistor for CLNA, CLNB, CLNC, CLND and CLNE

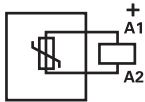

Type	Control Circuit	Ue	Catalog No.	Reference No.
Varistor	AC/DC	24V ... 48V	BSLV3G	104720
Varistor	AC/DC	50V ... 127V	BSLV3K	104721
Varistor	AC/DC	130V ... 250V	BSLV3R	104722
Varistor	AC/DC	277V ... 500V	BSLV3U	110836

Other Frontal Accessories to use with CLNA, CLNB, CLNC and CLNE



Pneumatic Timer: Adjustable time-delayed auxiliary contacts. They come equipped with two time-delayed contacts 1NO and 1NC, electrically separated. To mount a pneumatic timer, simply clip on front face.

Number of Contacts	Contacts				Type	Time	Catalog No.	Reference No.
Terminal: screw								
2	0	0	1	1	Delay ON	0.1 - 30 sec.	BTLEF30C	104709
2	0	0	1	1	Delay ON	1 - 60 sec.	BTLEF60C	104710
2	0	0	1	1	Delay OFF	0.1 - 30 sec.	BTLEF30D	104711
2	0	0	1	1	Delay OFF	1 - 60 sec.	BTLEF60D	104712



Mechanical Latch: Used to convert a standard contactor to a mechanically held contactor. Easy to mount, it clips onto front face of contactor.

Voltage			Catalog No.	Reference No.
50 Hz AC	60 Hz AC	DC		
24-32	24-32	24-36	RMLFD	112992
42-48	48-60	42-48	RMLFG	112993
		60-72	RMLFHC	112991
110-127	110-127	110-125	RMLFJ	112994
220-240	208-277	220-250	RMLFN	112995
380-480	380-480	440	RMLFU	112996
500-690	600		RMLFY	112997



Electronic Timer Module: High repeatability Time-ON and Time-OFF delay modules for sequencing control of contactors. A red LED provides indication during time-delay operation. Fixation to the coil terminals, that allows simultaneous use with the auxiliary contact blocks.

Control Circuit	Type	Time	Catalog No.	Reference No.
24-250V AC/DC	Delay ON	0.1 - 2 sec.	BETL02C	113602
24-250V AC/DC	Delay ON	1.5 - 45 sec.	BETL45C	113603
24-250V AC/DC	Delay OFF	0.1 - 2 sec.	BETL02D	113604
24-250V AC/DC	Delay OFF	1.5 - 45 sec.	BETL45D	113605



Thermal Overload Relays: Series RT



- Class 10 Thermal protection against overloads
- Protection against long starting times
- Automatic ambient temperature compensation
- Trip indication, Tripping TEST
- Independent auxiliary contacts with double rupture 1NO+1NC. Contact Rating: A600, Q600
- 4 Function selector:

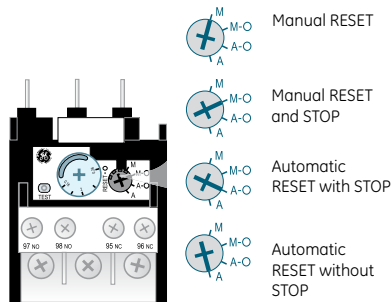

To mount on CLNA, CLNB and CLNC



Setting Range (regulation)		Screw Terminal	
Min. A	Max. A	Catalog No.	Reference No.
A	A		
0.16	0.26	RT1B	113700
0.25	0.41	RT1C	113701
0.4	0.65	RT1D	113702
0.65	1.1	RT1F	113703
1.0	1.5	RT1G	113704
1.3	1.9	RT1H	113705
1.8	2.7	RT1J	113706
2.5	4.0	RT1K	113707
4.0	6.3	RT1L	113708
5.5	8.5	RT1M	113709
8.0	12.0	RT1N	113710
10.0	16.0	RT1P	113711
14.5	18.0	RT1S	113712
17.5	22.0	RT1T	113713
21.0	26.0	RT1U	113714
25.0	32.0	RT1V	113715
30.0	40.0	RT1W	113716
Base for separate mounting		RTXP	105170

To mount on CLND and CLNE



Setting Range (regulation)		Screw Terminal	
Min. A	Max. A	Catalog No.	Reference No.
A	A		
11.5	15.0	RT2A	113717
14.5	19.0	RT2B	113718
18.5	25.0	RT2C	113719
24.0	32.0	RT2D	113720
30.0	43.0	RT2E	113721
42.0	55.0	RT2G	113722
54.0	65.0	RT2H	113723
64.0	82.0	RT2J	113724
78.0	97.0	RT2L	113725
90.0	110	RT2M	113726
Base for separate mounting		RT2XP	113764

To mount on CLNF or separate mounting



Setting Range (regulation)		Screw Terminal	
Min. A	Max. A	Catalog No.	Reference No.
A	A		
55	80	RT3B	113727
63	90	RT3C	113728
90	120	RT3D	113729
110	140	RT3E	113730
140	190	RT3F	113731

Accessories for Series RT



Remote Electrical Reset: Used in applications where the motor starter is inaccessible or in automated control systems where it is required to reset the OL relay remotely after the fault has been cleared. Electrical reset coils are rated for intermittent duty and use with momentary contacts.

- Minimum time 0.2sec ON for reliable operation. Power consumption is 100VA.
- Maximum duty: 1sec ON and 30sec OFF, 5sec ON and 90sec OFF, 10sec ON and 180sec OFF.

Voltage 50/60 Hz AC or DC	Catalog No.	Reference No.
12	RTXRRB	113661
24	RTXRRD	113662
48	RTXRRG	113663
110-120	RTXRRJ	113664
220-240	RTXRRN	113665
380-415	RTXRRU	113666
440-480	RTXRRX	113667

Electronic Overload Relays: Series RE



- Selectable Class 5, 10, 20 and 30 Protection against overload
- Greater accuracy, full reliability
- Self-powered
- Thermal memory
- Trip indication, Tripping TEST
- Independent auxiliary contacts with double rupture 1NO+1NC.
Contact Rating: A600, Q600
- Manual / Auto RESET

To mount on CLNA, CLNB and CLNC



Setting Range (A)		Catalog No.	Reference No.
Min.	Max.		
0.1	0.5	RE1D	101866
0.4	2	RE1H	101867
1.0	5	RE1K	101868
1.6	8	RE1M	101869
6.4	32	RE1S	101870
9.0	45	RE1W	101871
Base for separate mounting		RE1XP	247302

To mount on CLND and CLNE



Setting Range (A)		Catalog No.	Reference No.
Min.	Max.		
15	75	RE2H	101872
22	110	RE2M	101873
Base for separate mounting		RE2XP	247303

To mount on CLNF or separate mounting



Setting Range (A)		Catalog No.	Reference No.
Min.	Max.		
30	150	RE3E	101874

Accessories for Series RE

Description	Catalog No.	Reference No.
Transparent cover for pushbutton reset	RETC	247795

Series RE and RT, Flexible Cable Reset Button

For remote mechanical reset



Description	Length	Catalog No.	Reference No.
Frontal Mount	19.3 in	RTXS	113855
Frontal Mount	39.3 in	RTXSL	113856
Back Mount		RTXBS	108864

Overload Relays Tripping Curves

Series RT1

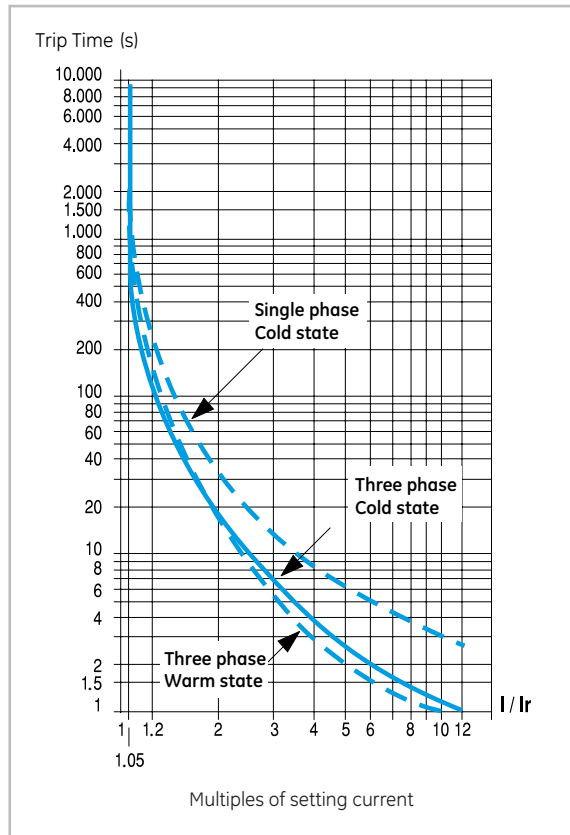

Series RT2

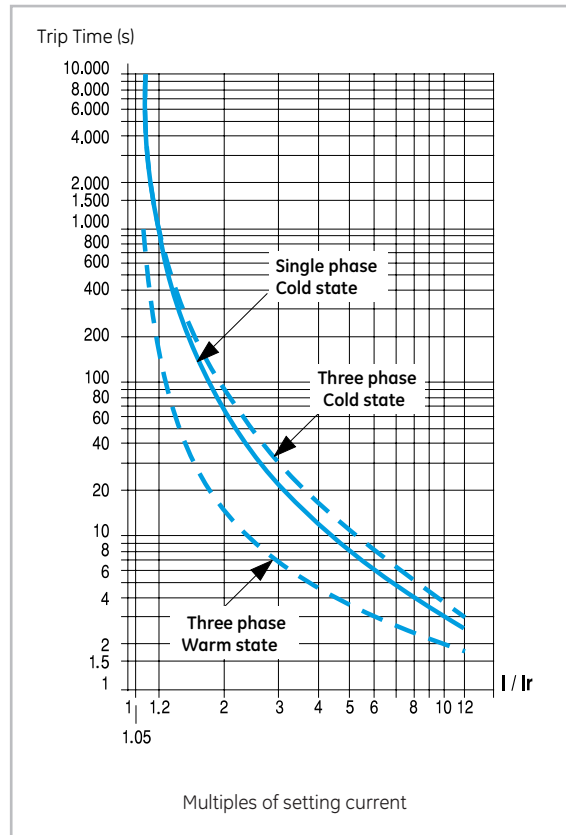

Series RT3 Class 10

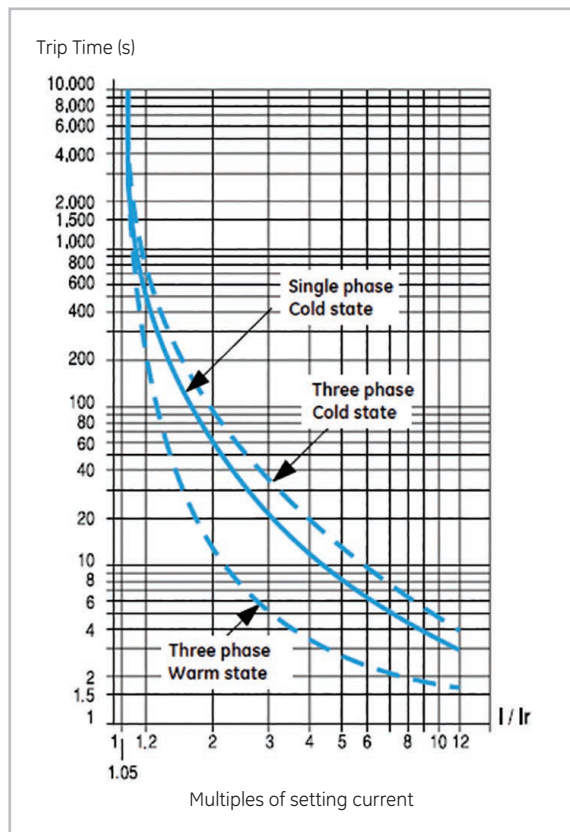

Series RE

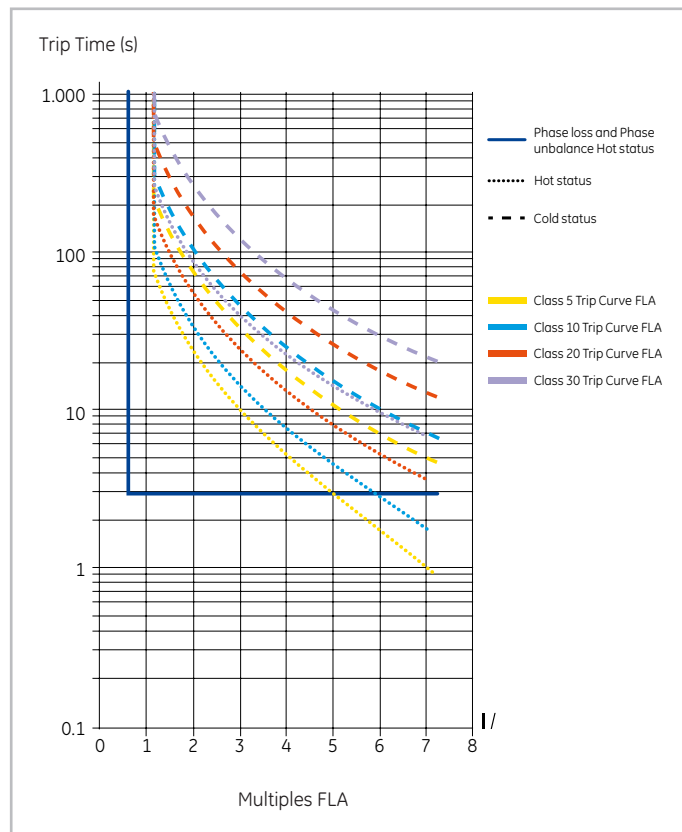

Technical data for CLN Contactors

* Technical data for OL relays and accessories can be found in general IEC catalog; Controls and Power Electronics

Mounting positions

CLNA, CLNB, CLNC, CLND and CLNE

- With the same pick-up and drop-out voltage
- With the same rated power

CLNF

- With the same pick-up and drop-out voltage
- With the same rated power

Terminal capacity and tightening torque

	Terminal Type	CLNA	CLNB	CLNC	CLND	CLNE	CLNF
A	AWG Wires	14..8	14..8				
	Tightening torque (LB x in.)	15	20				
B	AWG Wires			14..6	14..1/0	10..1/0	
	Tightening torque (LB x in.)			16	40	60	
C	AWG Wires						4..0
	Busbars (mm)						2 (25 x 5)
	Tightening torque (LB x in.)						70



Technical data for CLN Contactors

Power Circuit

Description	Maximum Horsepower NEMA Size					
	00	0	1	2	3	4
Normal Starting Duty HP Rating⁽¹⁾						
Single Phase						
115V 60Hz	1/3	1	2	3	7 1/2	NA
230V 60Hz	1	2	3	7 1/2	15	NA
Three Phase						
200V 60Hz	1 1/2	3	7 1/2	10	25	40
230V 60Hz	1 1/2	3	7 1/2	15	30	50
380-415V 50Hz	1 1/2	5	10	25	50	75
460V 60Hz	2	5	10	25	50	100
575V 60Hz	2	5	10	25	50	100
Plugging or Jogging HP Rating⁽¹⁾						
Single Phase						
115V 60Hz	NA	1/2	1	2	5	NA
230V 60Hz	NA	1	2	5	10	NA
Three Phase						
200V 60Hz	NA	1 1/2	3	7 1/2	15	25
230V 60Hz	NA	1 1/2	3	10	20	30
380-415V 50Hz	NA	1 1/2	5	15	30	50
460V 60Hz	NA	2	5	15	30	60
575V 60Hz	NA	2	5	15	30	60
Continuous Current Max						
Starters and Enclosed Contactors	9	18	27	45	90	135
Open Contactors	10	20	30	50	100	150

(1) When operation of the controller requires jogging (inching) or plug stopping or when normal operation requires continued operation in excess of 5 operations per minute or 10 operations in a 10-minute period, the plugging or jogging horsepower ratings must be followed.

Control Circuit

Description	Unit	Contactor Type					
		CLNA	CLNB	CLNC	CLND	CLNE	CLNF
Rated insulation Voltage Ui	V	1000	1000	1000	1000	1000	1000
Voltage Operating limits							
Operating	xUs	0.85...1.1	0.85...1.1	0.85...1.1	0.85...1.1	0.85...1.1	0.80...1.1
Pick-up	xUs	0.65...0.85	0.65...0.85	0.7...0.85	0.7...0.85	0.7...0.85	0.8
Seal	xUs	0.35...0.55	0.35...0.55	0.4...0.6	0.4...0.6	0.4...0.6	0.2...0.75
Circuit Closed (motor running)							
Consumption	VA	6	6	9.5	9.5	9.5	3.1
Power factor	cos	0.33	0.33	0.28	0.26	0.26	aprox 1
Circuit Open (motor starting)							
Consumption	VA	48	48	100	204	204	225
Power factor	cos	0.84	0.73	0.73	0.54	0.54	aprox 1
Opening and closing times at Us							
Time on energization	ms	250	320	450	920	1050	1600
Time on de-energization	ms	25	35	50	100	160	200



Drawings (inches/mm)

CLN Contactors

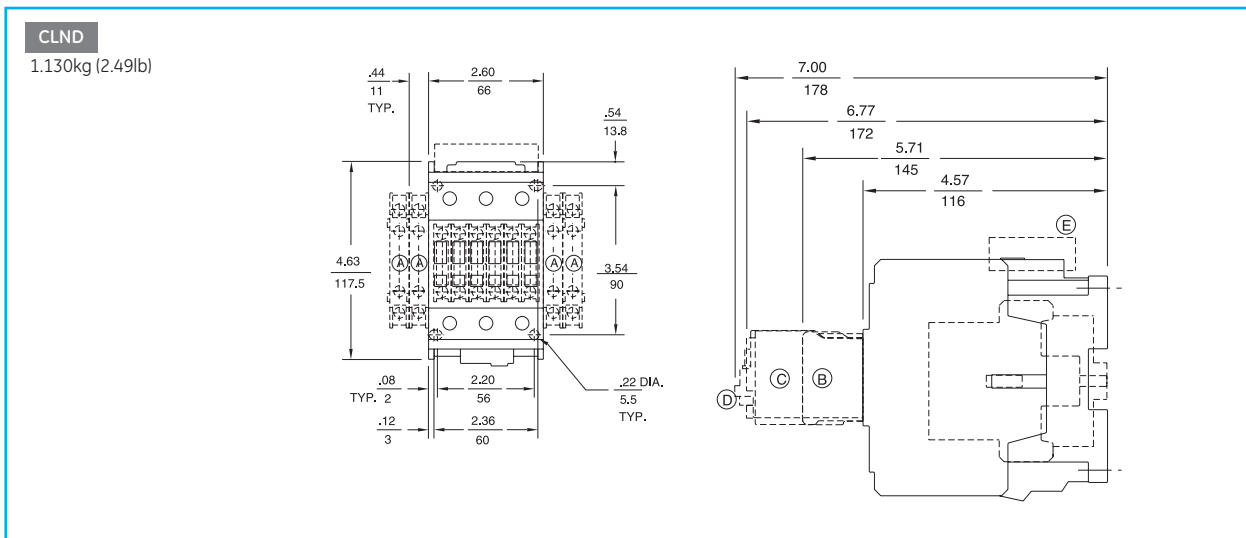
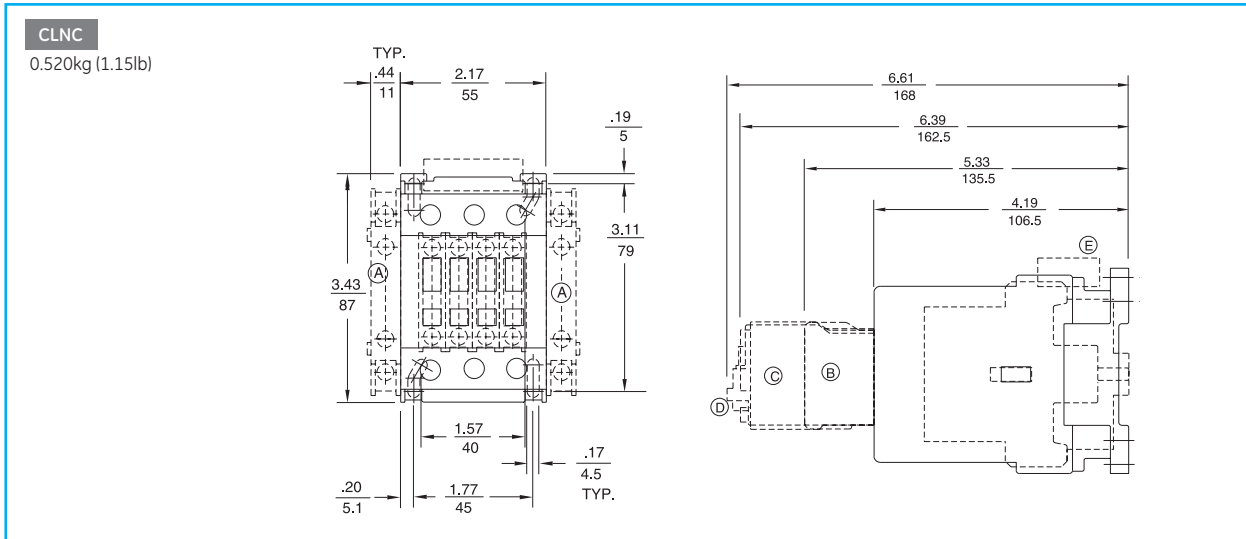

Legend and Notes

- A Extra Auxiliary Contacts, Side Mounted (if used)
- B Extra Auxiliary Contacts, Front Mounted (if used)
- C Pneumatic Timer (if used)
- D Mechanical Latch (if used)
- E Transient Voltage Suppressor

Drawings (inches/mm)

CLN Contactors

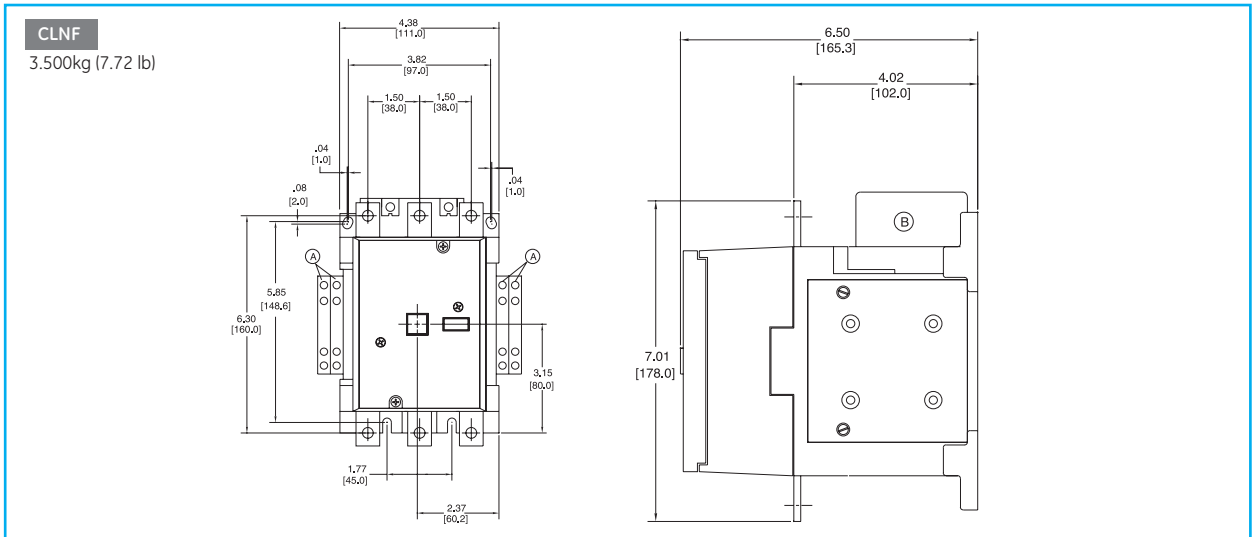
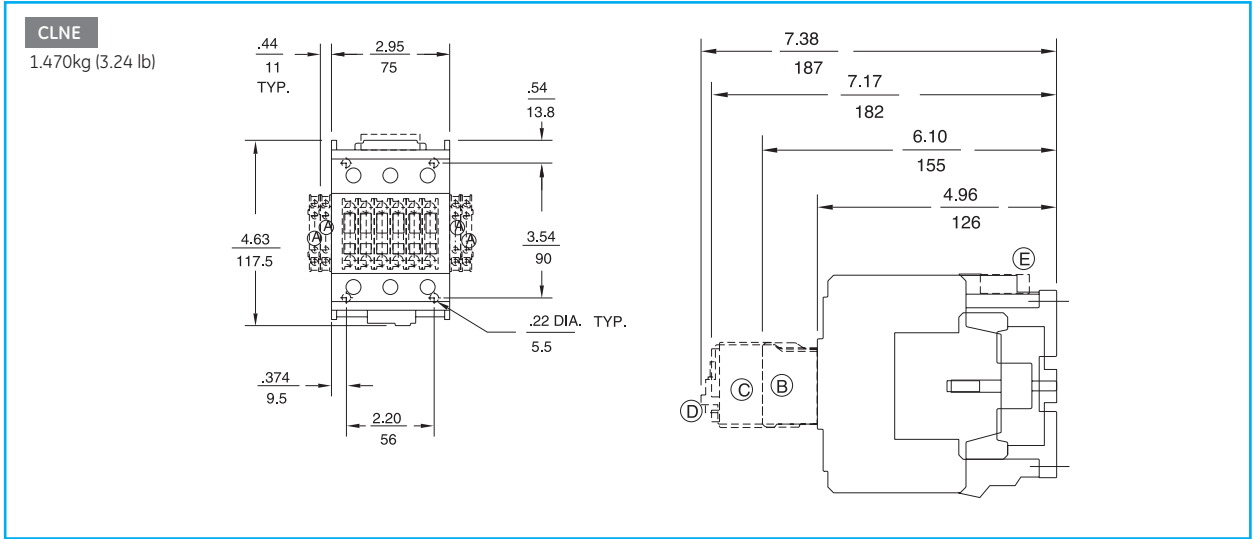

Legend and Notes

- A Extra Auxiliary Contacts, Side Mounted (if used)
- B Extra Auxiliary Contacts, Front Mounted (if used)
- C Pneumatic Timer (if used)
- D Mechanical Latch (if used)
- E Transient Voltage Suppressor



Drawings (inches/mm)

CLN Contactors + Overload Relay

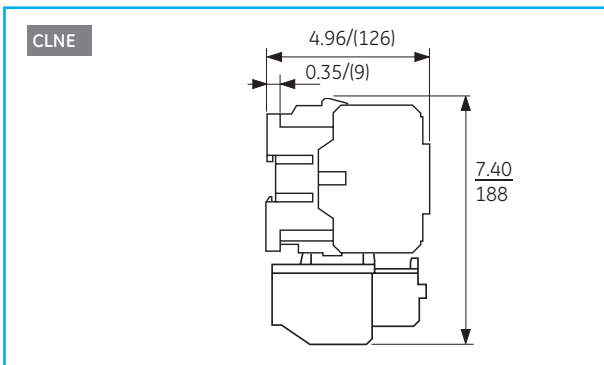
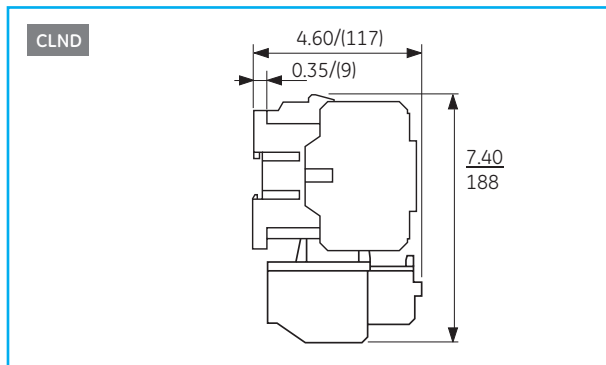
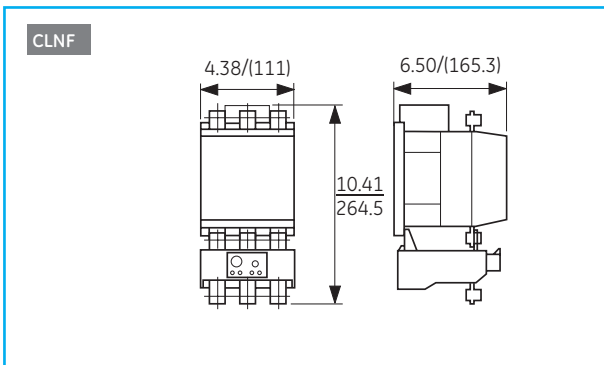
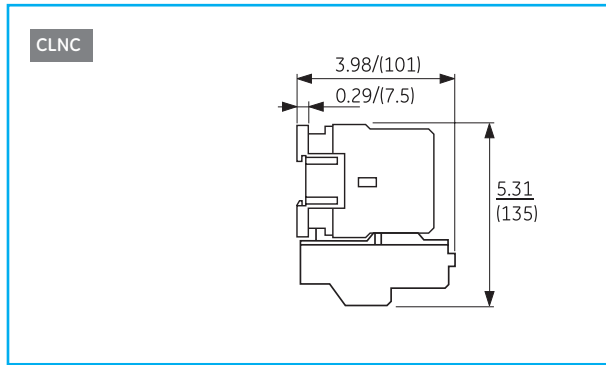
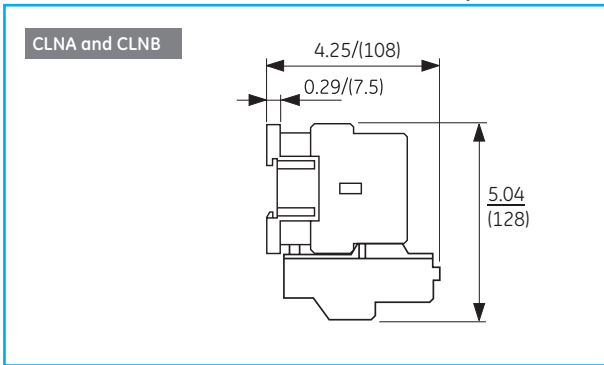

Reversing Mechanical Interlock

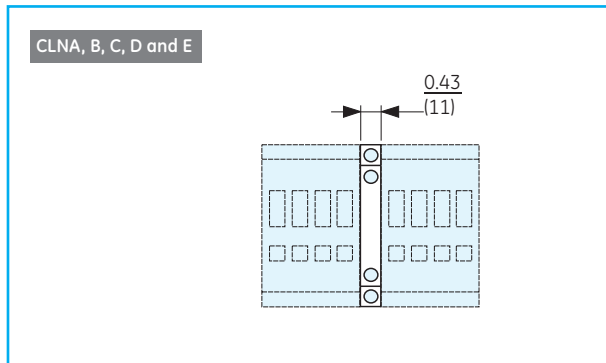
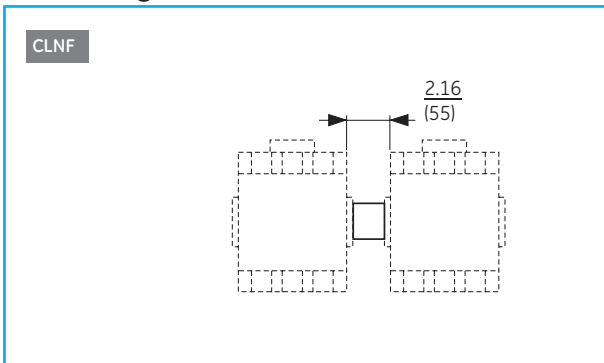

Everything is under control



Standards

Complying with:

- IEC 60947-3
- EN 60947-3
- DIN VDE 0660 Teil 107
- low voltage directive 73/73 EEC
- low voltage directive EMC 89/336 EEC

Approvals/Marking



Main switches

A manual operated main switch must be provided for every main circuit. It must be a switch-disconnector corresponding to utilization category AC23 (IEC 947-3) fulfils the following requirements:

- Disconnecting the electrical equipment from the main.
- Visible contact indication or a disconnection function by construction (the handle is in the "OFF" position when all contacts are open).
- If the main switch does not serve simultaneously as an emergency-stop switch, its handle should not be red. Black or grey handles are recommended.
- It should be lockable in the off-position (e.g. by padlock).
- All active conductors are to be disconnected from the main.
- The breaking capacity should be sufficient. In order to break the current of the largest motor in a blocked state together with the sum of the operating currents of the remaining motors/loads.
- The handle of the main switch must be easily accessible and must lie between 0.6 and 1.9m above the incomer level.

Emergency-stop switches

The main switch may fulfil the function of an emergency-stop switch on certain machines.

The handles must be red on a yellow background.

The contacts of manual operated emergency-stop switch has to be opened by force.

Mounting

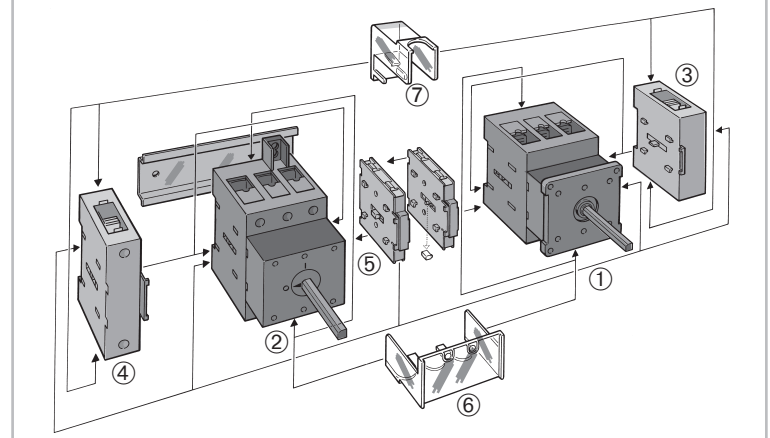

- ① Front mounting (flush mounting)
- ② Rear mounting
- ③ Main contact and PE-or N-terminals for ①
- ④ Main contact and PE-or N-terminals for ②
- ⑤ Auxiliary switch 1NO/1NG for ① and ②
- ⑥ Terminal cover triple for ① and ②
- ⑦ Terminal cover single for ③ and ④

Mounting possibilities ● page E.3
 Accessories ● page E.6
 Technical data ● page E.8
 Dimensions ● page E.9







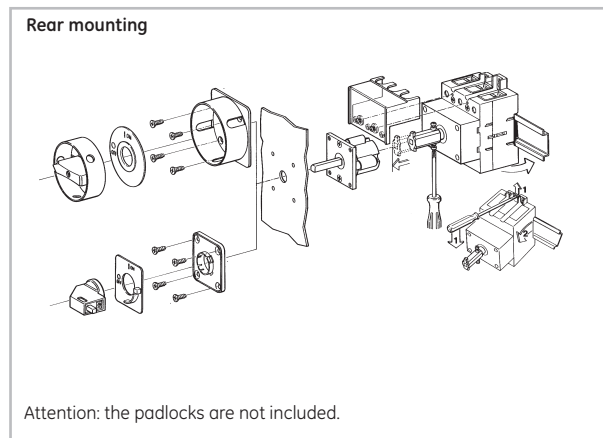
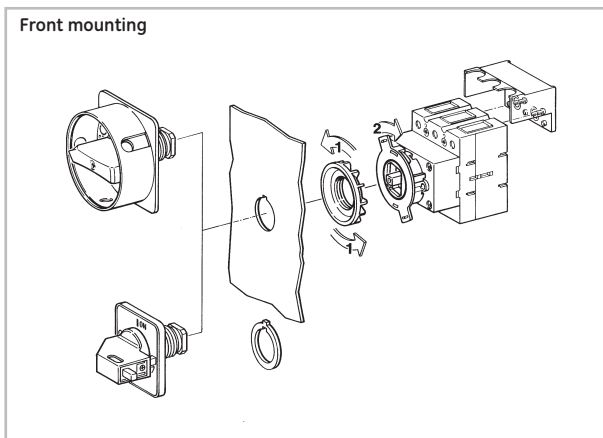

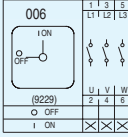

Mounting possibilities

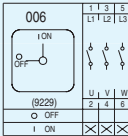

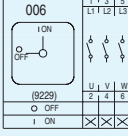

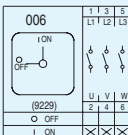

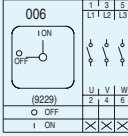

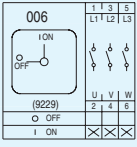

	Ith Series Colour	25A ML 1	40A ML 1	63A ML 2	80A ML 2	125A ML 3
Front mounting (flush mounting)						
Central fixing						
Ø 22.5mm for 3 padlocks	red/yellow	789178	789179			
Ø 22.5mm for 3 padlocks	black	789180	789181			
Ø 22.5mm for 1 or 2 padlocks	red/yellow	789174	789175			
Ø 22.5mm for 1 or 2 padlocks	black	789176	789177			
4-hole fixing						
With standard handle	black	789239	789240	789241	789242	789243
For 3 padlocks	red/yellow	789186	789187	789188	789189	789190
For 3 padlocks	black	789191	789192	789193	789194	789195
For 1 or 2 padlocks	red/yellow	789182	789183			
For 1 or 2 padlocks	black	789184	789185			
Rear mounting						
With cover coupling						
For 3 padlocks	red/yellow	789200	789201	789202	789203	789204
For 3 padlocks	black	789205	789206	789207	789208	789209
For 1 or 2 padlocks	red/yellow	789196	789197			
For 1 or 2 padlocks	black	789198	789199			
With door coupling						
For 3 padlocks	red/yellow	789214	789215	789216	789217	789218
For 3 padlocks	black	789219	789220	789221	789122	789223
For 1 or 2 padlocks	red/yellow	789210	789211			
For 1 or 2 padlocks	black	789212	789213			
DIN-rail mounting						
With standard handle	black	789234	789235	789236	789237	789238
For 1 or 2 padlocks	red/yellow	789224	789225	789226	789227	789228
For 1 or 2 padlocks	black	789229	789230	789231	789232	789233

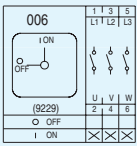

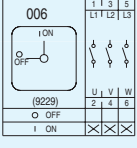
Standard programme

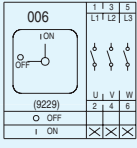
Central fixing Ø 22.5mm		Diagram	Terminal cover	Protection	Ithe	Red/yellow Ref. no.	Black/grey Ref. no.	Pack.
 <p>Locking handle by 1 or 2 padlocks</p>		✓	IP65	25A	789174	789176	1	
		✓	IP65	40A	789175	789177	1	
 <p>Locking handle by 3 padlocks</p>		✓	IP65	25A	789178	789180	1	
		✓	IP65	40A	789179	789181	1	
<p>4-hole fixing</p>  <p>Locking handle by 1 or 2 padlocks</p>		✓	IP55	25A	789182	789184	1	
		✓	IP55	40A	789183	789185	1	
 <p>Locking handle by 3 padlocks</p>		✓	IP55	25A	789186	789191	1	
		✓	IP55	40A	789187	789192	1	
		✓	IP55	63A	789188	789193	1	
		✓	IP55	80A	789189	789194	1	
		✓	IP55	125A	789190	789195	1	
 <p>With standard black handle</p>		-	IP55	25A	-	789239	1	
		-	IP55	40A	-	789240	1	
		-	IP55	63A	-	789241	1	
		-	IP55	80A	-	789242	1	
		-	IP55	125A	-	789243	1	

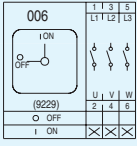
Standard programme

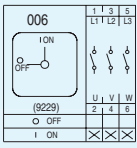
DIN-rail mounting		Diagram	Terminal cover	Protection	Ithe	Red/yellow Ref. no.	Black/grey Ref. no.	Pack.
 <p>Locking handle by 1 or 2 padlocks</p>		✓	IP30	25A	789224	789229	1	
		✓	IP30	40A	789225	789230	1	
		✓	IP30	25A	789226	789231	1	
		✓	IP30	25A	789227	789232	1	
		✓	IP30	40A	789228	789233	1	
 <p>With standard black handle</p>		-	IP30	25A	-	789234	1	
		-	IP30	40A	-	789235	1	
		-	IP30	63A	-	789236	1	
		-	IP30	80A	-	789237	1	
		-	IP30	125A	-	789238	1	
With door coupling								
 <p>Locking handle by 1 or 2 padlocks</p>		✓	IP55	25A	789210	789212	1	
		✓	IP55	40A	789211	789213	1	
 <p>Locking handle by 3 padlocks</p>		✓	IP55	25A	789214	789219	1	
		✓	IP55	40A	789215	789220	1	
		✓	IP55	63A	789216	789221	1	
		✓	IP55	80A	789217	789222	1	
		✓	IP55	125A	789218	789223	1	
With door coupling								
 <p>Locking handle by 1 or 2 padlocks</p>		✓	IP65	25A	789196	789198	1	
		✓	IP65	40A	789197	789199	1	
 <p>Locking handle by 3 padlocks</p>		✓	IP65	25A	789200	789205	1	
		✓	IP65	40A	789201	789206	1	
		✓	IP65	63A	789202	789207	1	
		✓	IP65	80A	789203	789208	1	
		✓	IP65	125A	789204	789209	1	

Accessories see E.6



Accessories - Contact blocks⁽¹⁾



Neutral switched		
Front	Rear	
789244	789245	1
Series ML1		
789246	789247	1
Series ML2		
789248	789249	1
Series ML3		

Fixed neutral module		
Front	Rear	
789262	789263	1
Series ML1		
789264	789265	1
Series ML2		
789266	789267	3
Series ML3		



Switching contact		
Front	Rear	
789250	789251	1
Series ML1		
789252	789253	1
Series ML2		
789254	789255	1
Series ML3		

Auxiliary contact NO+NC Ith = 16A		
Front	Rear	
789268	789269	1
Series ML1		
789268	789269	1
Series ML2		
789268	789269	1
Series ML3		



PE-terminal (Fixed)		
Front	Rear	
789256	789257	1
Series ML1		
789258	789259	1
Series ML2		
789260	789261	1
Series ML3		

Accessories - Terminal cover



Single terminal cover (HS1)		
Series ML1	789270	1
Series ML2	789271	1
Series ML3	789271	1

Triple terminal cover (HS3)		
Series ML1	789272	1
Series ML2	789273	1
Series ML3	789274	1
Same cover for front or rear mounting		



Standard programme



Shaft length	Depth range between door and base (mm)		Cat. no.
	ML1	ML2, ML3	
AL-65	170 - 215mm	185 - 320mm	789275
AL-165	265 - 335mm	280 - 350mm	789276
AL-265 ⁽²⁾	365 - 435mm	380 - 450mm	789277
AL-365 ⁽²⁾	465 - 535mm	480 - 550mm	789278
Shaft support for 265 and 365mm			789279

An extension shaft is necessary when the depth is higher than the length of the standard shaft.
ML1: 105-135mm
ML2 and ML3: 120-150mm

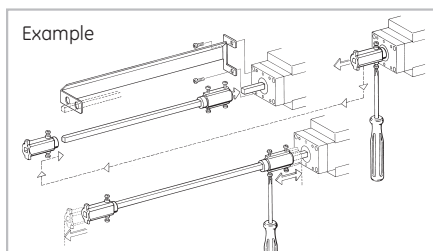

(1) ML1: max. 2 units
ML2 and ML3: max 3 units
(2) Shaft support included.

Enclosed switches



The maintenance switch is an enclosed main switch with locking handle by 3 padlocks. With red handle and yellow front plate, if it should be used as an emergency-stop switch, otherwise black/grey.

There are six sizes of standard enclosures for the series ML. Each is equipped with a cover coupling and a double PE-terminal.

All enclosures have a degree of protection IP65 and are of solid impact and flame resistant polyester.

Enclosed switches

	Diagram	Ithe	Type of enclosure	Black/grey 3 padlocks Ref. no.	Red/yellow 3 padlocks Ref. no.	Pack.
Three poles		25A	E2	789285	789280	1
		32A	E3	789286	789281	1
		50A	E4	789287	789282	1
		63A	E5	789288	789283	1
		100A	E7	789289	789284	1
Four poles		25A	E2	789295	789290	1
		32A	E3	789296	789291	1
		50A	E4	789297	789292	1
		63A	E5	789298	789293	1
		100A	E7	789299	789294	1
Three poles + (1 NO + 1 NC)		25A	E2	789305	789300	1
		32A	E3	789306	789301	1
		50A	E4	789307	789302	1
		63A	E5	789308	789303	1
		100A	E7	789309	789304	1
Four poles + (1 NO + 1 NC)		25A	E2	789315	789310	1
		32A	E3	789316	789311	1
		50A	E4	789317	789312	1
		63A	E5	789318	789313	1
		100A	E7	789319	789314	1
Six poles		25A	E2	789325	789320	1
		32A	E3	789326	789321	1
		50A	E4	789327	789322	1
		63A	E5	789328	789323	1
		100A	E7	789329	789324	1
Six poles + (1 NO + 1 NC)		25A	E2	789335	789330	1
		32A	E3	789336	789331	1
		50A	E4	789337	789332	1
		63A	E5	789338	789333	1
		100A	E7	789339	789334	1

Accessories see E.6



Technical data

Main switches - According to IEC 60947-3, EN 60947-3, DIN VDE 0660 part 107, UL and CSA

Series		ML 1	ML 1	ML 2	ML 2	ML 3	
Rated uninterrupted current	$I_{u \text{ open}} = I_{th}$	(A)	25	40	63	80	125
	$I_{th \text{ enclosed}}$	(A)	25	32	50	63	100
Rated insulation voltage U_i (III/3)		(V)	690	690	690	690	690
Rated impulse withstand voltage U_{imp} (III/3)		(kV)	6	6	6	6	6
Rated operational current I_e AC21 A ⁽³⁾		(A)	25	40	63	80	125
Rated operational voltage U_e		(V)	690	690	690	690	690
Frequency		(Hz)	50/60	50/60	50/60	50/60	50/60
Making/breaking capacity							
Utilization category AC3:	3 × 230V	(kW)	5.5	7.5	15	18.5	22
Motor switches for	3 × 400V	(kW)	7.5	11	22	30	37
operational switching	3 × 690V	(kW)	7.5	11	22	30	45
Utilization category AC23A ⁽³⁾	3 × 230V	(kW)	7.5	11	18.5	22	25
Motor switches	3 × 400V	(kW)	11	15	30 ⁽¹⁾	37 ⁽²⁾	45
(Main switches for machinery)	3 × 690V	(kW)	11	15	30 ⁽¹⁾	37 ⁽²⁾	45
Rated breaking category AC23 A ⁽³⁾	3 × 230V	(A)	260	390	630	750	870
	3 × 400V	(A)	220	300	570	700	850
	3 × 690V	(A)	130	170	330	400	490
Short-circuit capacity							
Max. fuse rating gG		(A)	50	50	80	80	125
Rated conditional short-circuit current		(kA _{eff})	10	10	-	-	-
Rated short-circuit making capacity I_{cm}		(kA)	-	-	2.1	2.1	3.4
Rated short-time withstand I_{cw} (1s-current)		(A _{eff})	300	480	765	960	1500
Disconnect function up to		(V)	690	690	690	690	690
Terminal screws (Pozidriv)			M4	M4	M5	M5	M6
Torque terminal screws		(Nm)	2.5	2.5	4	4	4.5
Cable cross section							
Solid or multi-stranded (Cu)		min. - max. (mm ²)	1.5-10	1.5-10	2.5-35	2.5-35	6-70
Flexible with ferrule (DIN 46228)		min. - max. (mm ²)	1.5-6	1.5-6	1.5-25	1.5-25	6-50
General purpose 3-phase		(A)	25	40	63	80	125
		(V)	600	600	600	600	600
Motor 3-phase	240V	(HP)	7.5	10	15	20	25
	480V	(HP)	10	20	30	40	50
	600V	(HP)	10	20	30	40	50
Motor 1-phase (2 pole)	120V	(HP)	1	1.5	3	4	6
	240V	(HP)	2	3	7.5	10	15
Cable cross section		AWG-No	14-7	14-3	14-2	14-2	8-1/0

(1) 22 kW in enclosure

(2) 30 kW in enclosure

(3) ML2/ML3 according to EN 60947-3 category B

Auxiliary contact for main switches - According to IEC 60947-5-1

Series		ML 1/2/3	
Rated uninterrupted current	$I_{u \text{ open}} = I_{th}$	(A)	16
	$I_{th \text{ enclosed}}$	(A)	16
Rated insulation voltage U_i (III/3)		(V)	690
Rated impulse withstand voltage U_{imp}		(kV)	6
Rated operational current	I_e (AC15)		
	230V	(A)	6
	400V	(A)	4
	690V	(A)	2
Max. fuse rating gG		(A)	16
Rated conditional short-circuit current		(kA _{eff})	3
Cable cross section, solid or multi-stranded		min. - max. (mm ²)	1-4
Flexible with ferrule (DIN 46228)		min. - max. (mm ²)	1-2.5
Terminal screws (Pozidriv)			M3
Torque terminal screws		(Nm)	0.6

Dimensional drawings

Front mounting - Central fixing \varnothing 22.5mm

For 1 or 2 padlocks, \varnothing max. 5mm

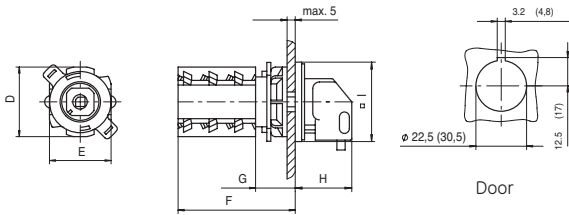

Series	D	E	F	G	H	I
ML1	55	45	75	25	35	48

For 3 padlocks, \varnothing max. 9mm

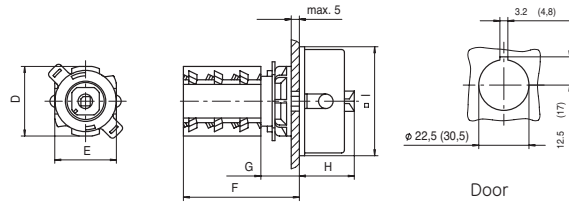

Series	D	E	F	G	H	I
ML1	55	45	75	25	35	66

Front mounting - 4-hole fixing

For 1 or 2 padlocks, \varnothing max. 5mm

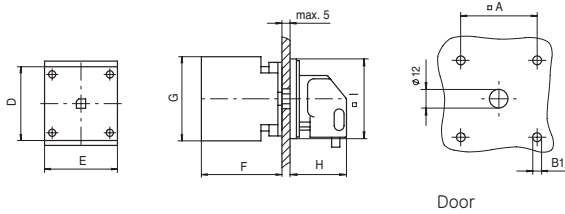

Series	A	B1	D	E	F	G	H	I
ML1	36	4.5	44	44	50	55	35	48

For 3 padlocks, \varnothing max. 5mm

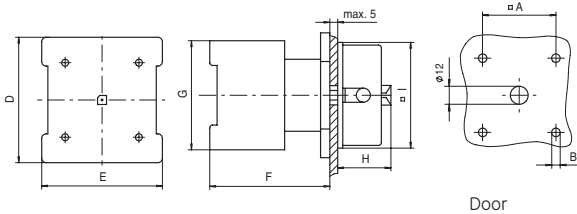

Series	A	B1	D	E	F	G	H	I
ML1	36	4.5	44	44	50	55	32	66
ML2	48	5.5	58	58	72	75	37	86
ML3	48	5.5	78	78	72	80	37	86

Front mounting - 4-hole fixing, with standard black handle

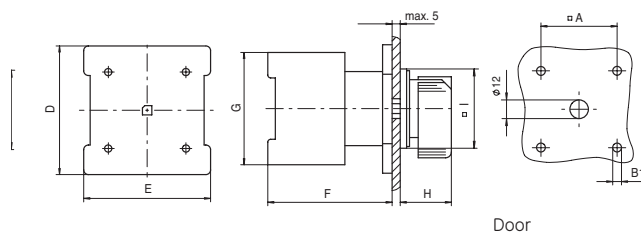

Series	A	B1	D	E	F	G	H	I
ML1	36	4.5	44	44	50	55	29	48
ML2	48	5.5	58	58	72	75	33	64
ML3	69	5.5	78	78	72	80	35	88

Dimensional drawings

Rear mounting - DIN-rail mounting

With standard black handle

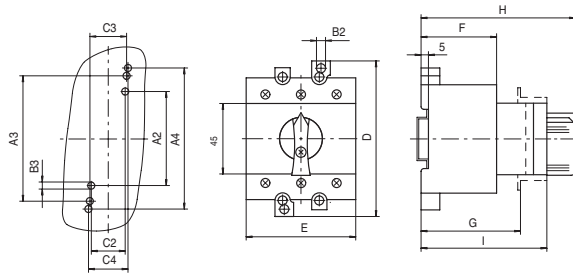

Series	A2	A3	A4	B2	B3	C2	C3
ML1	60	65	70	4.2	3.8	22	30
ML2	-	80	90	5.5	5.2	-	23.5
ML3	-	80	90	5.5	5.2	-	23.5
Series	C4	D	E	F	G	H	I
ML1	25	78	52.5	42	48.5	87.5	67.5
ML2	25	100	53.5	49	-	100	79
ML3	25	100	70	49	-	100	79

For 1 or 2 padlocks, Ø max. 5mm

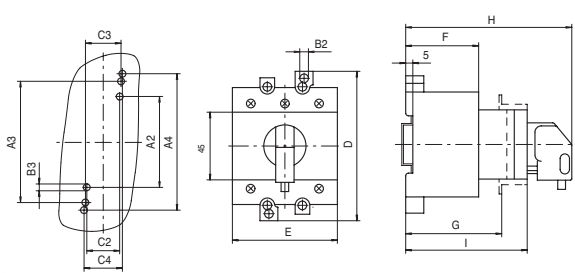

Series	A2	A3	A4	B2	B3	C2	C3
ML1	60	65	70	4.2	3.8	22	30
ML2	-	80	90	5.5	5.2	-	23.5
ML3	-	80	90	5.5	5.2	-	23.5
Series	C4	D	E	F	G	H	I
ML1	25	78	52.5	42	48.5	91.5	67.5
ML2	25	100	53.5	49	-	104	79
ML3	25	100	70	79	-	104	79

Rear mounting - With door coupling

For 1 or 2 padlocks, Ø max. 5mm

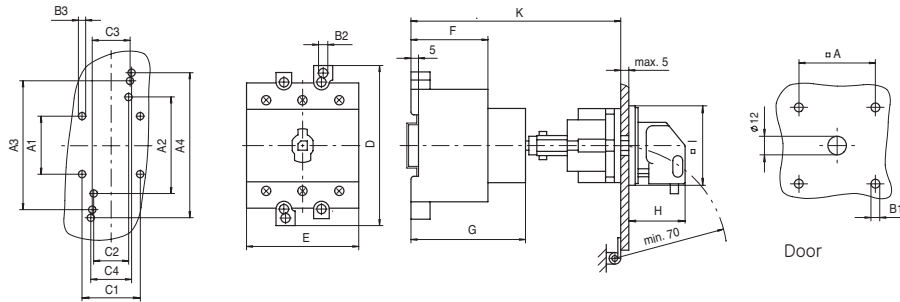

Series	A	A2	A3	A4	B1	B2	B3	C2	C3	C4	D	E	F	G	H	I	K
ML1	36	60	65	70	4.5	4.2	3.8	22	30	25	78	45	42	55	35	48	105-135

For 3 padlocks, Ø max. 5mm

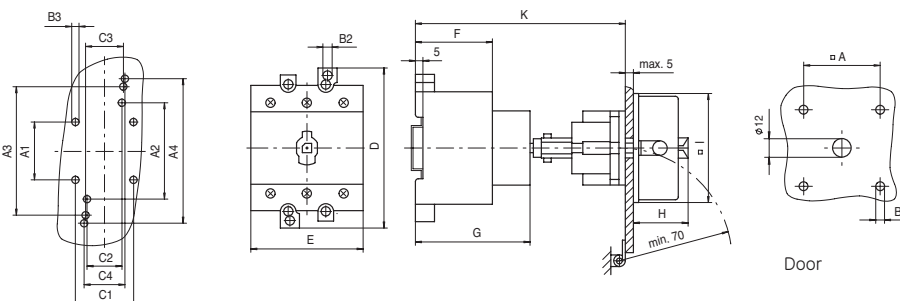

Series	A	A2	A3	A4	B1	B2	B3	C2	C3	C4	D	E	F	G	H	I	K
ML1	36	60	65	70	4.5	4.2	3.8	22	30	25	78	45	42	55	32	66	105-135
ML2	36	-	80	90	5.5	5.5	5.2	-	23.5	25	100	53.5	49	72	37	86	120-150
ML3	36	-	80	90	5.5	5.5	5.2	-	23.5	25	100	70	49	72	37	86	120-150

Dimensions in mm (inch = mm x 0.03937) - Weight in kg (lb = kg x 2.2046)



Rear mounting - With cover coupling

For 1 or 2 padlocks, Ø max. 9mm

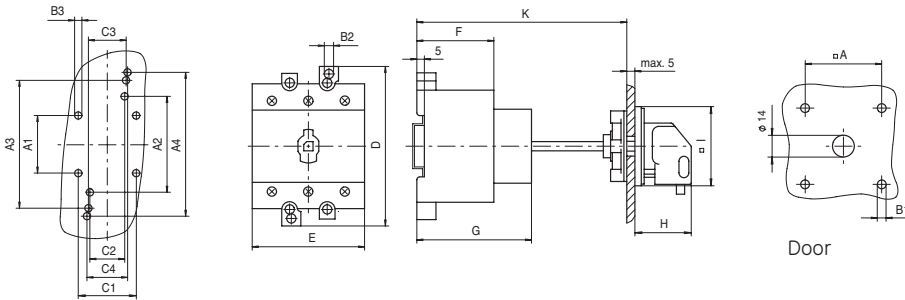

Series	A	A2	A3	A4	B1	B2	B3	C2	C3	C4	D	E	F	G	H	I	K
ML1	36	60	65	70	4.5	4.2	3.8	22	30	25	78	45	42	55	35	48	105-135

For 3 padlocks, Ø max. 9mm

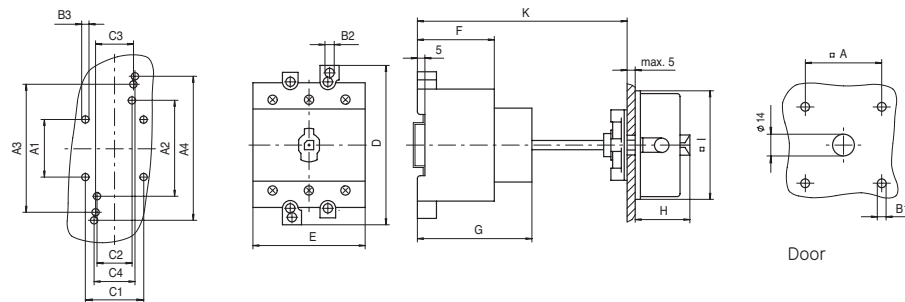

Series	A	A2	A3	A4	B1	B2	B3	C2	C3	C4	D	E	F	G	H	I	K
ML1	36	60	65	70	4.5	4.2	3.8	22	30	25	78	45	42	55	32	66	88-98
ML2	36	-	80	90	5.5	5.5	5.2	-	23.5	25	100	53.5	49	72	37	86	103-113
ML3	36	-	80	90	5.5	5.5	5.2	-	23.5	25	100	70	49	72	37	86	103-113

Enclosed switches

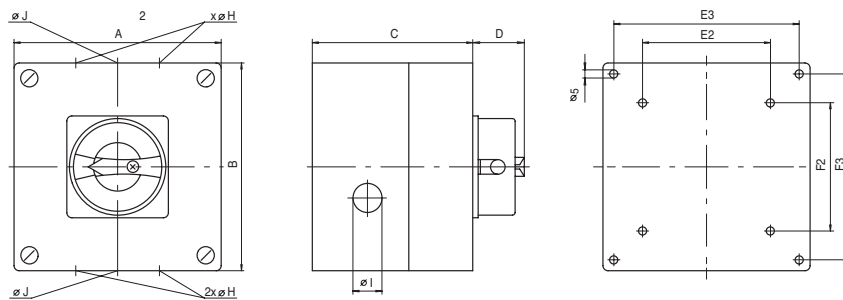

Enclosure								
Type	A	B	C	D	E2	E3	F2	F3
E2	94	130	81	32	-	79	-	115
E3	130	130	99	32	-	115	-	115
E4	110	180	11	32	50	95	120	165
E5	180	182	111	37	120	165	120	167
E6	180	254	111	37	120	165	190	239
E7	265	265	140	37	194	-	230	-

Cable entry					
Type	H (1)	I (1)	H (2)	I (2)	J (2)
E2	PG 16/11	PG 11	-	-	-
E3	PG 21/16	PG 16	-	-	-
E4	-	-	PG 21	PG 11	-
E5	-	-	PG 29	-	PG 11
E6	-	-	PG 29	PG 11	-
E7	PG 36/29	PG 29	-	-	-

(1) Knock-out entry
(2) Cable entry

Dimensions in mm (inch = mm x 0.03937) - Weight in kg (lb = kg x 2.2046)



Dimensions

Intro

A

B

C

D

E

F

G

H

I

X

Series ML

Dimensional drawings

Accessories

N-module and PE-terminal

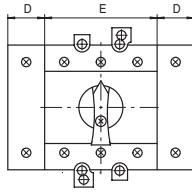

Series	D	E
ML1	14.5	45
ML2	23	53.5
ML3	23	70

Auxiliary contacts (NO + NC)

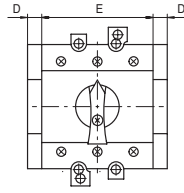

Series	D	E
ML1	9.5	45
ML2	9.5	53.5
ML3	9.5	70

Terminal covers

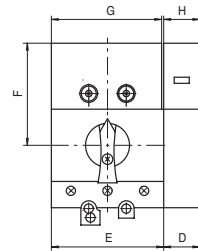

Series	D	E	F	G	H
ML1	14.5	45	53	41	14
ML2	23	53.5	61	52	22.5
ML3	23	70	65	68	22.5

Dimensions in mm (inch = mm x 0.03937) - Weight in kg (lb = kg x 2.2046)



Switches for photovoltaic applications up to 1000V DC

To isolate the solar panels from the inverter, from 16 to 100A dc

- Available in 600 and 1000V DC
- Easy installation, ready to install
- Pre-wired for DC applications
- Compact size
- DIN rail mounting as standard, other configurations possible
- Clear identification of inputs and outputs
- Padlockable



Approvals/Marking



Technical data/Order codes

According IEC 60947-3	Ref. no.	Ref. no.						
		247532	247533	247534	817600	247536	247537	247538
Rated operational voltage U _e (+10%)	(VDC)	600	600	600	1000	1000	1000	1000
Rated impulse withstand voltage U _{imp}	(kV)	6	6	6	6	6	6	6
Rated thermal current, DC-20 I _{th}	(Adc)	16	25	40	40	63	80	100
In open air, normal conditions ⁽¹⁾								
Minimum cable or bar cross section - Cu	(mm ²)	2.5	6	10	10	35	35	35
Rated operational current								
600V DC	(Adc)	16	25	40	-	-	-	-
1000V DC	(Adc)	-	10	25	40	63	80	100
Power loss / Pole	(W)	1.5	1.5	1.5	1.5	4.5	5.5	3
Number of poles		2	3	3	6	8	8	8
Mechanical service life	(Ops)	30,000	30,000	30,000	30,000	30,000	30,000	30,000
Dimensions (HxWxD)	(mm)	78x46x55	78x46x55	78x46x55	78x97x55	100x90x73	100x105x73	100x105x73
Frontcover		- included	included	included	included	not available	not available	not available

(1) Defined by IEC 60947-1-6.1

Enclosed DC switch without surge protection

Description	Ref. no.	Pack.
Enclosure to protect DC entry at PV inverter level (1 for each inverter) Enclosure IP65 (130x130x100mm) DC switch 40A under 600V DC Clear identification of inputs/outputs DC connectors, type MC-4	817590	1

Everything is under control

			Intro
	POWER DEVICES	Contactors and overload relays	A
		Auxiliary relays and contactors	B
		Motor protection devices	C
		Applications	D
		Main switches	E
		Control and signalling units	F
	POWER ELECTRONICS	Speed drive units	G
		Soft starters	H
	ENCLOSURES	Product overview	I
		Alphabetical index	X

Series P9

F.2 Control and signalling units \varnothing 22mm

Series 077

F.44 Control and signalling units \varnothing 30mm

Series 105

F.61 Signalling devices

AUXILIARY DEVICES





- F.3 **Main features**
- F.4 **Range overview**
- F.6 **Technical data**
- F.8 **Overview**
- F.8 **Order codes - Panel mounting devices**
- F.12 Catalogue number structure
- F.13 Standard push-buttons
- F.14 Pilot Devices
- F.15 Double function push-buttons
- F.16 Selector switches with knob
- F.17 Selector switches with lever
- F.18 Selector switches with key
- F.20 Illuminated push-buttons
- F.20 Illuminated selector switches
- F.21 Selector push-buttons
- F.22 Emergency lever
- F.22 Reset push buttons
- F.22 Potentiometer operators
- F.22 Buzzers - Pilot lights
- F.23 Joysticks
- F.24 Contact blocks
- F.25 Power supplies
- F.26 Base mounting devices
- F.27 Electrical diagrams
- F.28 Push-button stations in thermoplastic
- F.29 Equipped boxes
- F.31 Push-button stations in aluminium
- F.32 Caps for standard push-buttons
- F.33 Diffusers/insert for illuminated units
- F.34 **Order codes - Common accessories**
- F.38 **Overall dimensions**
- F.38 Panel mounting
- F.43 Enclosures for push-button stations

Intro

A

B

C

D

E

F

G

H

I

X



Main features

Shape, material and colours



The P9 line offers three types of operators:

- round in satin chrome
- round in engineering thermoplastic
- square in engineering thermoplastic

Modern ergonomic P9 actuators are available in a wide variety of colours and styles, and are the result of superior industrial design experience.

Series P9 satisfies any sophisticated industrial applications.

Fitting and positioning

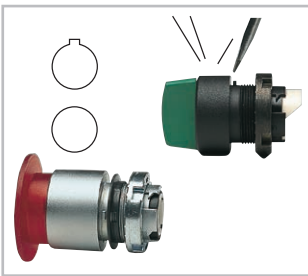

All the P9 operators are fitted with seal to ensure IP66 degree of protection.

A locating tab on the operator allows the correct positioning on panels with holes drilled according to CENELEC EN 50007 standards (with notch). The tab also ensures panel stability and prevents unwanted rotations.

The tab can be removed with a screwdriver for applications in holes without notch.

Rear locking and back mounting procedure



P9 operators are back mounted to the panel by a patented locking ring. The units can be assembled using a standard screwdriver.

As an option, an assembly wrench is available.

Fast mounting

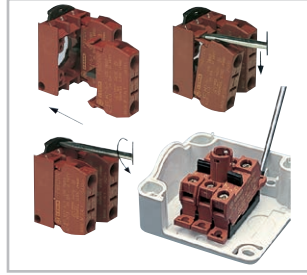

All the P9 rear panel devices are snap-on.

Mounting between panel and operator is accomplished by means of a patented snap-on flange which ensures a fast fitting.

For base mounting, the fitting is done directly on the adaptor inside the enclosure base.

Each single block can be mounted or removed individually.

In panel mounting, it is also possible to install or remove the snap-on mounting flange with the contact block group;

Blocks and/or flange can be disassembled by a standard screwdriver, to simplify operations.

Safety and reliability



The P9 contact blocks are designed to ensure maximum reliability in every condition and to monitor control circuits at low energy levels (12V-5mA) minimum, thanks to advanced solution such as:

- four contact points
- high efficiency self-cleaning operation
- silver contacts properly shaped
- high contact pressure

Mounting system



The P9 line offers a wide variety of operators, contact blocks and power supplies for panel mounting.

Furthermore a range of contact blocks and power supplies are available for base mounting.

The base mounting option is simple thanks to plastic enclosures fitted with a standard mounting adaptor, which allows a snap-on and secure fastening.

Intro

A

B

C

D

E

F

G

H

I

X

Panel mounting devices

Control units

 Standard push-b. F.13	 Mushroom push-button F.13	 Emergency push-button F.13	 Key push-button F.13	 Knob selector sw. F.16	 Lever selector sw. F.17
 Key selector sw. F.18	 Selector push-b. F.21	 Toggle switch F.21	 Joystick F.23	 Emergency lever F.22	 Double push-b. F.15

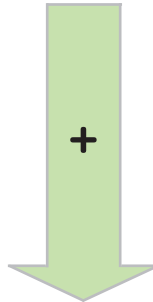

Contact blocks F.24				
------------------------	--	---	--	--

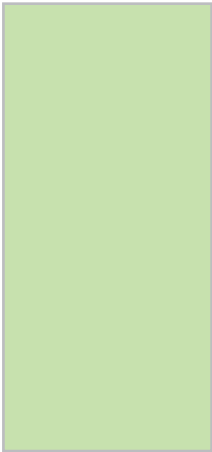

Illuminated control units Signalling units

Others units

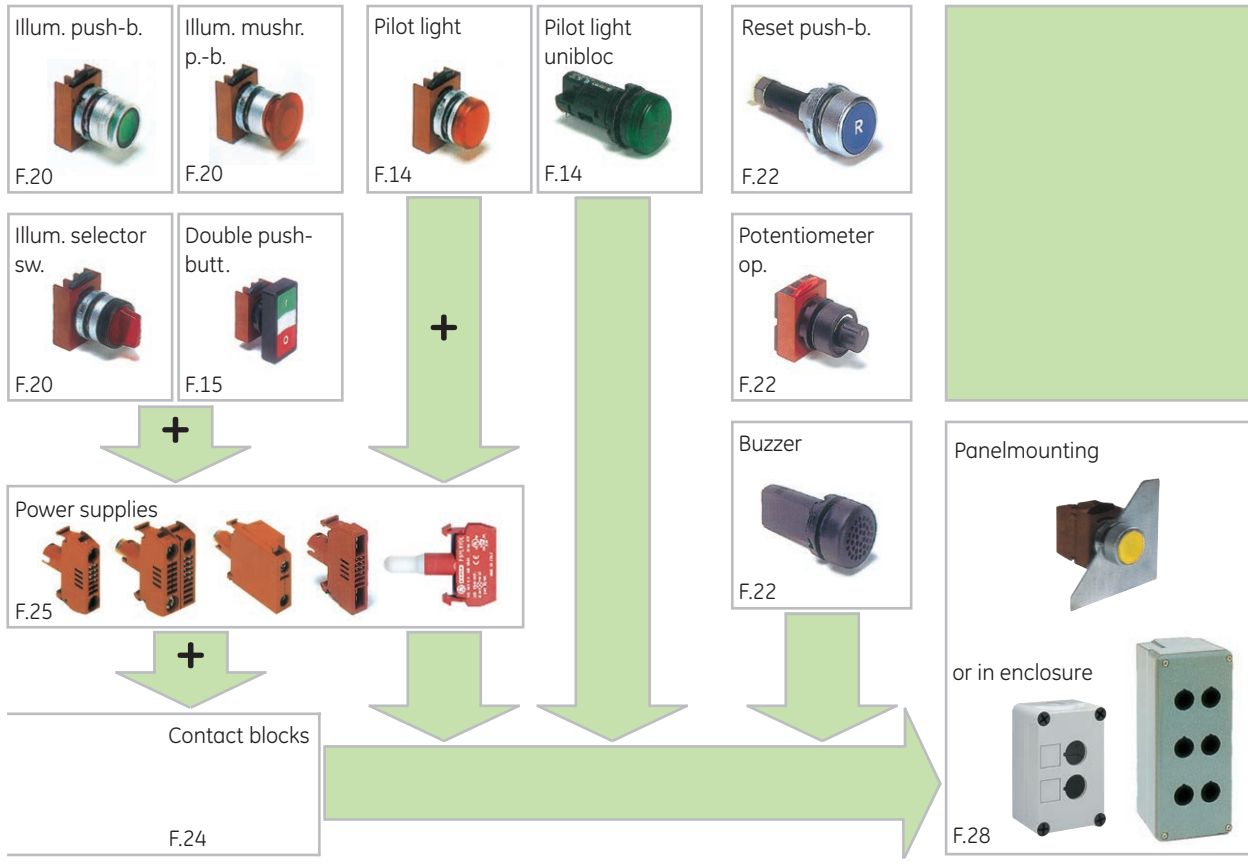

Accessories

General	Push-buttons	Mushroom push-buttons	Illuminated push-buttons	Illuminated mushroom push-buttons	Illuminated selector switches	Pilot lights
Nameplates F.55	Rubber caps F.32	Name plates F.36	Diffusers F.33	Collar F.34	Padlock F.34	Diffusers F.33s
Plugs F.34	Padlock F.34	Collar Ø 40 F.34	Padlock F.34			
Flanges F.34	Push-on/push-off device F.34		Push-on/push-off device F.34			
Ring wrench F.34			Bulbs BA9S F.35			
Neutral plate F.36	Keys F.35		Bulb extractor F.34			

Range overview

Intro

A

B

C

D

E

F

G

H

I

X



Series P9

Technical data

Compliance with standards

IEC 947.5.1 - VDE 0660 - NFC 63140
 IEC/EN 60947.5.1 - UTE - BSI - NEMA
 CENELEC EN 50007

Approvals

cUL U.S. - RINA - CE - GOST R - Lloyd's Register of Shipping -
 Bureau Veritas - Germanischer Lloyd

Climatic protections

The standard versions are suitable for use in the following climates:

Temperate climate	cat. 23/50 (DIN 50014)
Wet climate	cat. 23/83 (DIN 50015)
Hot wet climate	cat. 40/92 (DIN 50015)
Variable wet climate	FW24 (DIN 50016)

Temperature ranges

Operation	-30°C to +70°C
Storage	-40°C to +70°C

Protection degree of the operators

IP66 according to CENELEC EN 60529 when they are mounted into enclosures with the same or a higher degree of protection.

Suitable for using into enclosures type NEMA 1-3-3R-3S-4-4X-12-13 according to UL 508.

Protection degree of the terminals

IP2x according to CENELEC EN 60529.

Shock resistance (acc. to MIL 202 B method 202 A)

1/2 sinusoid 11ms:
 No damage or disassembling at 100g for all devices, except for the illuminated operators with transformer 38g.

Vibration resistance (according to IEC 68-2-6)

16 g with frequency range from 40 to 500Hz and maximum shifting 0.75mm (peak-to-peak).

Rated insulation voltage

690V according to EN 60947.1

Impulse withstand voltage

4 kV according to EN 60947.1

Insulation class

Groep C according VDE 0110

Electrical shocks protection (acc. IEC 536)

Metal operators	Class I
Plastic operators	Class II (double insulation)

Short-circuit protection

With fuses 16A gG according to IEC 269.1 and 269.3.

Performances of the contacts

- Slow acting
- Self-cleaning sliding
- NC forced breaking
- Double movable bridge
- Four switching points
- Double break

Electrical resistance of the contact

≤25m Ω according to IEC 255, cat. 3

Identification of the terminals

According CENELEC EN 50013

Electrical performances

Rated thermal current I_{th} = 10 A

Performances according IEC 947.5.1

Categorie AC 15									
Voltage	Ue (V)	24	48	60	110	220	380	500	600
Current	Ie (A)	10	10	10	6	3	2	1.5	1.2
Categorie DC 13									
Voltage	Ue (V)	24	48	60	110	220	300		
Current	Ie (A)	2.5	1.4	1	0.55	0.27	0.2		

Performances according to CSA and UL

AC Heavy Duty	(A600)
DC Standard Duty	(Q300)

Operating range

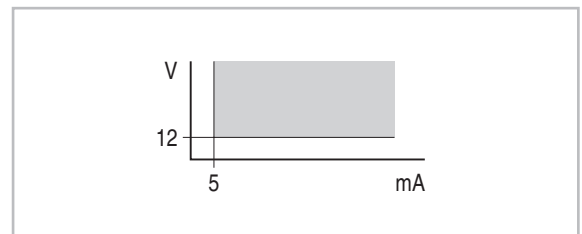

Electrical endurance

Alternative current 50/60 Hz cat. AC 15

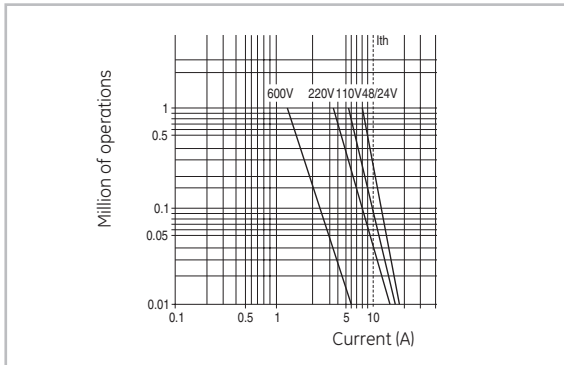

Direct current cat. DC 13

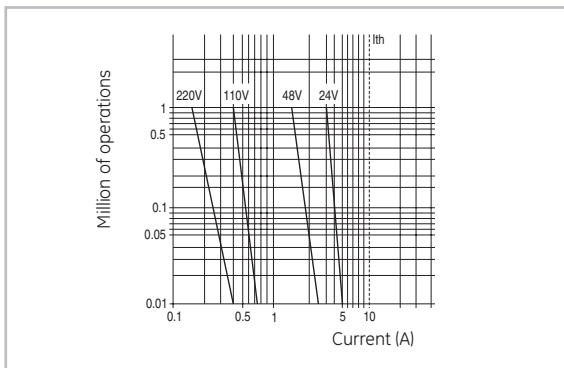

Mechanical endurance

Locking emergency	
Mushroom head push-buttons 3 positions	0.3 Mil./op.
Illuminated mushroom head push-buttons 3 pos.	
Joysticks	
Key push-buttons	
Toggle switches	0.5 Mil./op.
Illuminated selector switches	
Push-on push-off device	
Standard selector switches	
Key selector switches	
Illuminated push-buttons	1 Mil./op
Selector push-buttons	
Emergency lever	
Standard push-buttons	3 Mil./op.
Mushroom head push-buttons	

Rear panel modularity

The P9 series is composed with 10mm or a multiple of 10mm modular units, fitted side by side on a proper mounting flange. The standard operators are supplied with a three position flange with a capacity of 3 units of 10mm or 1 of 10mm and 1 of 20mm or 1 of 30mm.

When the three position flange is not enough to satisfy the applications needs, the five position flange is required to add two more units of 10mm mounted side by side.

Using the five position flange take into account the bigger with (50mm instead of 30mm).

Number of electrical contacts

	Flange	
	standard 3 positions	optional 5 positions
Standard push-buttons		
Mushroom head push-buttons	max 6	max 8
Emergency lever		
Standard selectors	max 4	max 8
Key selector switches		
Joysticks		
Key push-buttons	max 4	-
Selector push-buttons		
Toggle switches		
Mushroom head with lock	max 4	-
Mushroom head push-buttons 3 pos.	max 2	
Illuminated push-buttons		
Illuminated mushroom head push-buttons	max 4	max 4
Illuminated selector switches		
Illuminated mush. push-buttons with lock	max 2	max 2
Illuminated mush. push-buttons 3 pos.		

Mounting

Fitted for panels 1 to 6mm. thick with holes drilled according to CENELEC EN 50007 standards.

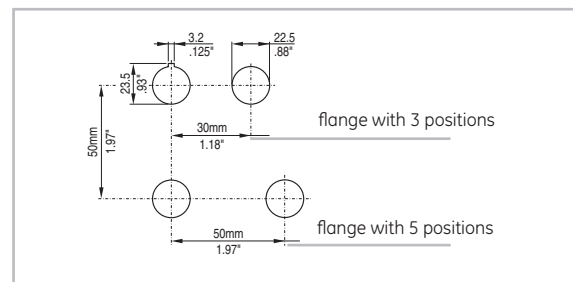

Standard control units

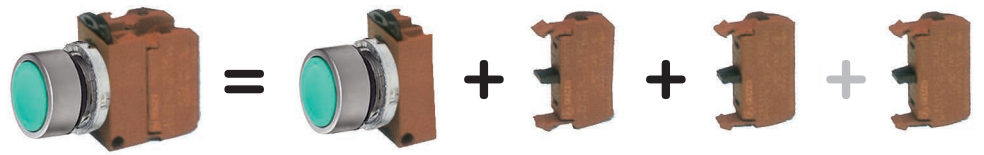

Push-button
with flush cap

Push-button
with raised cap

Push-button
mushroom head

Push-button
mushroom head
with latch
push-twist/pull/key
to release

Emergency
push-button
with positive break
push-twist to release
EN418

	Push-button with flush cap	Push-button with raised cap	Push-button mushroom head	Push-button mushroom head with latch push-twist/pull/key to release	Emergency push-button with positive break push-twist to release EN418
Round satin chrome P9M 	<p>P9MPN♦G Ref. no.</p> <ul style="list-style-type: none"> ●N.. 184000 ●R.. 184001 ●V.. 184002 ●G.. 184003 ●L.. 184006 ⊗O.. 184009 <p>⊗ = without cap</p>	<p>P9MPN♦S Ref. no.</p> <ul style="list-style-type: none"> ●N.. 184010 ●R.. 184011 ●V.. 184012 ●G.. 184013 ●L.. 184016 ⊗O.. 184019 <p>⊗ = without cap</p>	<p>ø 40 mm</p> <p>P9MEM4♦N Ref. no.</p> <ul style="list-style-type: none"> ●N.. 184030 ●R.. 184031 ●V.. 184032 ●G.. 184033 ●L.. 184046 	<p>ø 40 mm</p> <p>Ref. no.</p> <ul style="list-style-type: none"> ● P9MER4RN 184070 (push-twist to release) ● P9MET4RN1 184061 (push-pull to release) ● P9MEC4RN95 184073 (push-key to release) 	
Round plastic P9X 	<p>P9XPN♦G Ref. no.</p> <ul style="list-style-type: none"> ●N.. 185000 ●R.. 185001 ●V.. 185002 ●G.. 185003 ●L.. 185006 ⊗O.. 185009 <p>⊗ = without cap</p>	<p>P9XPN♦S Ref. no.</p> <ul style="list-style-type: none"> ●N.. 185010 ●R.. 185011 ●V.. 185012 ●G.. 185013 ●L.. 185016 ⊗O.. 185019 <p>⊗ = without cap</p>	<p>ø 40 mm</p> <p>P9XEM4♦N Ref. no.</p> <ul style="list-style-type: none"> ●N.. 185040 ●R.. 185041 	<p>ø 40 mm</p> <p>Ref. no.</p> <ul style="list-style-type: none"> ● P9XER4RN 185070 (push-twist to release) ● P9XET4RN1 185061 (push-pull to release) ● P9XEC4RN95 185074 (push-key to release) 	<p>ø 40 mm</p> <p>Ref. no.</p> <ul style="list-style-type: none"> ● P9XER4RAN 185077 (push-twist to release) ● P9XER4RAW 185078 (push-twist to release) ● P9XER4RA95N 185079 (push-key to release)









Caps for standard push-buttons

		Flush and recessed		Raised			
		Cat. no.	Ref. no.	Cat. no.	Ref. no.	◆ Complete the Cat. no. with: N R V G M L B H	
		◆ Complete the Ref. no. with: 0 1 2 3 4 6 7 8				Caps with text ⁽¹⁾	
Flush and recessed	Neutral caps select the colour and complete the code:	P9ARBG ♦	18710 ♦	P9ARBS ♦	18720 ♦		
	Caps with symbols ⁽¹⁾						
Flush and recessed	Stop	P9ARBGR 029	187150	P9ARBSR 029	187210	Reset (R)	
	Start	P9ARBGV 028	187112	P9ARBSV 028	187212	Stop/Reset (R)	
Raised	Continuous rectilinear motion	P9ARBGN 006	187117	P9ARBSN 006	187217	Test (T)	
		P9ARBGV 006	187118	P9ARBSV 006	187218	Stop (STOP)	
		P9ARBGB 006	187152	P9ARBSB 006	187252	Start (START)	
	Increase	P9ARBGN 017	187125	-	-		
	Decrease	P9ARBGN 018	187127	-	-		

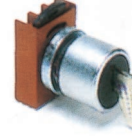
⁽¹⁾ Other symbols/text on request



Example:
 Green push-button in metal, round with flush cap
 + 2 contacts NO = P9 MPNVG + 2x P9 B10VN

Selector switch with knob	Selector switch with lever	Selector switch with key (code 3095) key removal in all positions	Joystick
 I-II fixed ● P9MSMD0N 184110 I-0-II fixed ● P9MSMZ0N →← 184200 I-0-II spring return ● P9MSMZ3N 184320	 I-II fixed ● P9MSVD0N 184370 I-0-II fixed ● P9MSVZ0N →← 184379 I-0-II spring return ● P9MSVZ3N 184391	 I-II fixed ● P9MSCD0K95 184402 I-0-II fixed ● P9MSCZ0T95 →← 184439 I-0-II spring return ● P9MSCZ3C95 184467	 fixed pos. ● P9MMN2F 184700 transient pos. ● P9MMN2T 184701 ④ ① ② ③ fixed pos. ● P9MMN4F 184720 transient pos. ● P9MMN4T 184721
 I-II fixed ● P9XSMD0N 185110 I-0-II fixed ● P9XSMZ0N →← 185200 I-0-II spring return ● P9XSMZ3N 185320	 I-II fixed ● P9XSVD0N 185370 I-0-II fixed ● P9XSVZ0N →← 185379 I-0-II spring return ● P9XSVZ3N 185391	 I-II fixed ● P9XSCD0K95 185402 I-0-II fixed ● P9XSCZ0T95 →← 185439 I-0-II spring return ● P9XSCZ3C95 185467	 fixed pos. ● P9XMN2F 185700 transient pos. ● P9XMN2T 185701 ④ ① ② ③ fixed pos. ● P9XMN4F 185720 transient pos. ● P9XMN4T 185721

	Flush and recessed		Raised	
	Cat. no.	Ref. no.	Cat. no.	Ref. no.
Blue	P9ARBGL 037	187143	-	-
Red	P9ARBGR 036	187144	-	-
Black	P9ARBGN 030	187145	P9ARBSN 030	187245
Green	P9ARBGV 030	187146	P9ARBSV 030	187246
Red	P9ARBGR 201	187147	P9ARBSR 201	187247
Green	P9ARBGV 202	187149	P9ARBSV 202	187249

Spare boots for joysticks

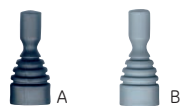

Cat./Ref. no.

Rubber boots	(A)
Standard	P9ARSCMN 188043
With interlock	P9ARSCMB 188044
Silicone boots	(B)
Standard	P9ARSGMN 187495
With interlock	P9ARSGMB 187496



Series P9

Illuminated control units

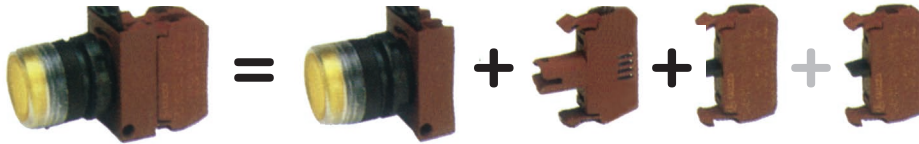

Control and signalling units Ø 22mm

Illuminated push-button with flush cap

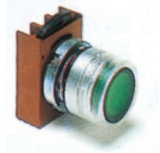

- P9MPL**◆GD Ref. no.
-R.. 184491
 -V.. 184492
 -G.. 184493
 -B.. 184497
 -L.. 184496

Illuminated push-button with raised cap

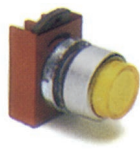

- P9MPL**◆SD Ref. no.
-R.. 184501
 -V.. 184502
 -G.. 184503
 -B.. 184507
 -L.. 184506

Illuminated push-button with mushroom head



- ø 40 mm
P9MEM4◆L Ref. no.
-R.. 184551
 -V.. 184552
 -G.. 184553
 -B.. 184557
 -L.. 184556

Illuminated push-button push-pull to release with mushroom head

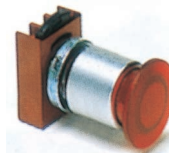

- ø 40 mm
● P9MET4RL1 184561

Illuminated selector switch



- I-II fixed Ref. no.
P9MSLD0R◆ 184591
I-O-II fixed
P9MSLZ0R◆ 184601
→←
I-O-II spring return
P9MSLZ3R◆ 184631
◆ Colour palette =
● R ● V ● G ● L



- P9XPL**◆GD Ref. no.
-R.. 185491
 -V.. 185492
 -G.. 185493
 -B.. 185497
 -L.. 185496



- P9XPL**◆SD Ref. no.
-R.. 185501
 -V.. 185502
 -G.. 185503
 -B.. 185507
 -L.. 185507



- ø 40 mm
P9XEM4◆L Ref. no.
-R.. 185551
 -V.. 185552
 -G.. 185553
 -L.. 185556

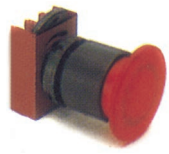

- ø 40 mm
● P9XETRRL1 185561

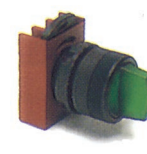

- I-II fixed Ref. no.
P9XSLD0R◆ 185591
I-O-II fixed
P9XSLZ0R◆ 185601
→←
I-O-II spring return
P9XSLZ3R◆ 185631
◆ Colour palette =
● R ● V ● G ● L

Diffusers/insert for illuminated units



For pilot lights



For illuminated push buttons

	For pilot lights		For illuminated push buttons	
	Cat. no.	Ref. no.	Cat. no.	Ref. no.
Neutral	P9ARDLS	187300	P9ARDPL	187350
With symbols ⁽¹⁾				
Stop	P9ARDLS029	187301	P9ARDPL029	187351
Start	P9ARDLS028	187302	P9ARDPL028	187352
Continuous rectilinear motion	P9ARDLS006	187305	P9ARDPL006	187355
Increase	P9ARDLS017	187309	P9ARDPL017	187359
Decrease	P9ARDLS018	187310	P9ARDPL018	187360

⁽¹⁾ Other symbols on request



Signalling units



Pilot light
diffused lens

Pilot light
unibloc
full voltage \approx BA9S
max. 2W not included



P9ML ◆D	Ref. no.
●R..	184791
●V..	184792
●G..	184793
○B..	184797
●L..	184796



P9XL ◆D	Ref. no.
●R..	185791
●V..	185792
●G..	185793
○B..	185797
●L..	185796

P9XU ◆DDO	Ref. no.
●R..	185821
●V..	185822
●G..	185823
○B..	185827
●L..	185826

Contact blocks

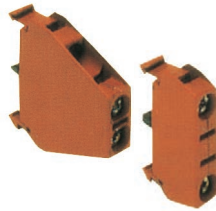

1 NC
1 NO
2 NC
1 NC + 1 NO
2 NO

Cat. no.

Ref. no.

P9B01VN	187001
P9B10VN	187002
P9B02VN	187008
P9B11VN	187000
P9B20VN	187009

Power supplies

Full voltage



Full voltage \approx
BA9S max. 380V-2W
not included

P9PDNV0

187020

Bulbs BA9s MultiLED



Vn AC/DC \pm 10%

Vn

Cat. no.

Ref. no.

■	6V AC/DC 12V AC/DC 24V AC/DC 48V AC/DC 110V AC/DC 230V AC	BA9S6LEDR BA9S12LEDR BA9S24LEDR BA9S48LEDR BA9S110LEDR BA9S230LEDR	187164 187169 187173 187178 187183 187188			
	■	6V AC/DC 12V AC/DC 24V AC/DC 48V AC/DC 110V AC/DC 230V AC	BA9S6LEDV BA9S12LEDV BA9S24LEDV BA9S48LEDV BA9S110LEDV BA9S230LEDV	187162 187167 187174 187179 187184 187189		
		■	6V AC/DC 12V AC/DC 24V AC/DC 48V AC/DC 110V AC/DC 230V AC	BA9S6LEDG BA9S12LEDG BA9S24LEDG BA9S48LEDG BA9S110LEDG BA9S230LEDG	187161 187168 187171 187176 187181 187186	
			■	6V AC/DC 12V AC/DC 24V AC/DC 48V AC/DC 110V AC/DC 230V AC	BA9S6LEDL BA9S12LEDL BA9S24LEDL BA9S48LEDL BA9S110LEDL BA9S230LEDL	187160 187166 187172 187177 187182 187187
				□	6V AC/DC 12V AC/DC 24V AC/DC 48V AC/DC 60V AC/DC 110V AC/DC 130V AC/DC 230V AC	BA9S6LEDB BA9S12LEDB BA9S24LEDB BA9S48LEDB BA9S60LEDB BA9S110LEDB BA9S130LEDB BA9S230LEDB



Catalogue number structure ⁽¹⁾

Push-buttons

P9		P				
STYLE	FORM	TYPE	CAP COLOUR	PUSH-BUTTON TYPE	LENS TYPE	
Panel mounting M = Round satin chrome X = Round plastic C = Round polished chrome S = Square plastic	P = Push-Button	N = Non illuminated L = Illuminated	N = Black R = Red V = Green G = Yellow L = Blue B = White	G = Flush S = Extended E = Recessed	D = Diffusor for illuminated push-button only	

Selector switches

P9		S				
STYLE	FORM	TYPE	CAM	SPRING RETURN	COLOUR or KEY REMOVAL	
Panel mounting M = Round satin chrome X = Round plastic C = Round polished chrome S = Square plastic	S = Selector switches	M = Knob V = Lever L = Illuminated Knob C = Key operated	D, I or H = 2 positions E, L, U or Z = 3 positions X = 4 positions	0 = Fixed 3 = From left & right L → 0 ← R 1 = L → 5 = ← R	N = Black R = Red V = Green G = Yellow L = Blue	

Pilot lights

P9		L		
STYLE	FORM	TYPE	LENS TYPE	
Panel mounting M = Round satin chrome X = Round plastic C = Round polished chrome S = Square plastic	L = Pilot light	R = Red V = Green G = Yellow B = White	D = Diffused	

Contact blocks

P9	B				
FORM	NORMALLY OPEN CONTACTS	NORMALLY CLOSED CONTACTS	TERMINAL TYPE	CONTACT TYPE	
B = Contact Block	0 = None 1 = 1 NO	0 = None 1 = 1 NC	V = Standard screw B = Base mounting screw F = Faston	N = Normal A = Early closing R = Late opening	

Power supplies

P9	P				
FORM	TYPE	STYLE	TERMINAL TYPE	VOLTAGE	
P = Power supplies	D = Full voltage R = Resistor T = Transformer L = Led	0 = Normal M = Multi-function (continuous/blinking) D = Diode L = Long life T = Test F = Flashin	V = Standard screw B = Base mounting screw F = Faston	0 = Full voltage D = 24V J = 110-120V N = 220-240V	

⁽¹⁾ Nomenclature keys are indicative only. Do not use for orders.



Push-buttons

		Description	Cat. no.		Ref. no.		Cat. no.		Ref. no.	
			Metal	Plastic	Plastic	see bottom	see bottom	see bottom	see bottom	
Standard / Momentary										
	With flush cap		P9MPN●G				P9XPN●G			P9SPN●G
	With raised cap		P9MPN●S				P9XPN●S			P9SPN●S
	Recessed		P9MPN●E							
Mushroom head / Momentary										
	Mushroom head Ø 28mm		P9MEM3●N				P9XEM3●N⁽¹⁾			
	Mushroom head Ø 40mm		P9MEM4●N				P9XEM4●N⁽¹⁾			
	Mushroom head Ø 60mm		P9MEM6●N						P9SEM3RN	186031
	Mushroom head ∇ 30mm									
Mushroom head with latch										
	Standard Push-pull to release	Mushroom head Ø 40mm	P9MET4●N1				P9XET4●N1			P9SET4R 186061
	Push-twist to release	Red mushroom head Ø 28mm	P9MER3RN	184070		P9XER3RN	185070			
		Red mushroom head Ø 40mm	P9MER4RN	184071		P9XER4RN	185071			
Push-key to release	Red mushroom head Ø 40mm	P9MEC4RN▲				P9XEC4RN▲				
Emergency with latch										
	Positive break in accordance with EN 418	Push-twist to release	RED mushroom head Ø 40mm				P9XER4RAN	185077		P9SER4RA 186072
	Push-twist to release	Red mushroom head Ø 40mm with status indication					P9XER4RAW	185078		
		Push-key to release	Red mushroom head Ø 40mm with key code 3095				P9XEC4RA95N	185079		P9SEC4RA95 186073
Mushroom head / 3 positions										
	Ø 40mm 1-0 fixed, 2 transient		P9MET4●N2							
	Ø 40mm 0 fixed, 1-2 transient		P9MET4●N3							
With keylock ⁽²⁾										
	Key withdrawable in position I & II	normal	P9MPCN1K▲							
		depressed	P9MPCN2K▲							
		normal & depressed	P9MPCN3K▲							
	Key with drawable position II	normal	P9MPCN1E▲							
		depressed	P9MPCN2E▲							
		normal & depressed	P9MPCN3E▲							

(1) Color N or R
(2) Keys on F.18



The catalogue numbers in **bold** are available from stock.

Colours	●	black	red	green	yellow	brown	blue	white	grey	without cap
Caps	●	N	R	V	G	M	L	B	H	0
Mushroom heads	●	N	R	V	G	-	L	-	-	-

Remark: To complete the catalogue number, substitute the symbol ● by a letter for the choice of the colour and the symbol ▲ by a number for the type of key.



Pilot Devices

Description	Cat. no.	Ref. no. <i>see bottom</i>	Cat. no.	Ref. no. <i>see bottom</i>	Cat. no.	Ref. no. <i>see bottom</i>
	Metal		Plastic		Plastic	
						
Standard Diffused lens Refracted lens (for neon bulb) Glass lens	P9ML●D P9ML●R P9ML●V		P9XL●D		P9SL●D	
Unibloc (complete pilot light) Full voltage AC/DC BA9S max 382 V - 2 W not included Diffused lens			P9XU●DD0			

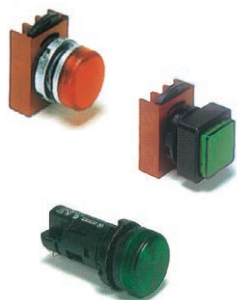

The catalogue numbers in **bold** are available from stock.



Colours								
Lens								

Unibloc (Multi-LED BA9S included)

Voltage	Colour	Cat. no.	Ref. no.
24Vac/dc	Red	P9XURDDD	205238
	Green	P9XUVDDD	205239
	Yellow	P9XUGDDD	205240
	Blue	P9XULDDD	205241
	White	P9XUBDDD	205242
110-120Vac/dc	Red	P9XURDDJ	205243
	Green	P9XUVDDJ	205244
	Yellow	P9XUGDDJ	205245
	Blue	P9XULDDJ	205246
	White	P9XUBDDJ	205247
230Vac	Red	P9XURDDN	213701
	Green	P9XUVDDN	213702
	Yellow	P9XUGDDN	213703
	Blue	P9XULDDN	213704
	White	P9XUBDDN	213705





Bulbs BA9s

Description	Cat. no.	Ref. no.	
			Plastic
			
Filament type	Vn	W	
	6	0.6	BA9S606 187850
	6	1.5	BA9S615 187851
	12	2.0	BA9S122 187852
	24	2.0	BA9S242 187853
	30	2.1	BA9S30 187854
	48	2.0	BA9S48 187855
	60	1.2	BA9S6012 187856
	130	2.0	BA9S130 187857
	220	2.0	BA9S220 187868
Neon type	110	0.11	BA9SN110 187860
	220	0.33	BA9SN220 187861
MultiLED	VN AC/DC ±10%		
	6		BA9S6LED•
	12		BA9S12LED•
	24		BA9S24LED•
	48		BA9S48LED•
	60		BA9S60LED 187191
	110-120		BA9S110LED•
	130		BA9S130LED 187190
	(AC) 230		BA9S230LED•



Colours					
					

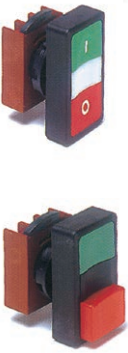
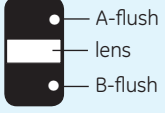
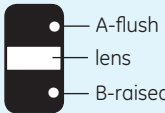











Double function push-buttons⁽¹⁾

	Description	Colours	Plastic caps without symbols		Plastic with symbols	
			Cat. no.	Ref. no.	Cat. no.	Ref. no.
<p>IP40 protection (acc. to IEC 529)</p> 						
	With white lens assembled for indicator light. Black insert for not illuminated function included in the packaging.	A - Black B - Red	P9DPLNRG00	186880	P9DPLNRG01	186890
		A - Green B - Red	P9DPLVRG00	186881	P9DPLVRG01	186891
		A - Black B - Red	P9DPLNRS00	186882	P9DPLNRS01	186892
		A - Green B - Red	P9DPLVRS00	186883	P9DPLVRS01	186893
<p>Clear cap (silicon rubber)</p> 						
	IP66 protection (acc. to IEC 529)	A - flush B - flush	080CPDT	173208	080CPDT	173208
		A - Green B - raised	P9ADCST	187796	P9ADCST	187796

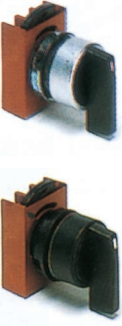
(1) With white lens assembled.
Black insert for not illuminated function included in the packaging.

The catalogue numbers in **bold** are available from stock.

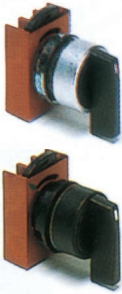
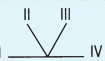
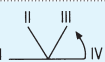
Selector switches with lever

	Function ⁽¹⁾	Cat. no.		Ref. no.		
		Metal		Plastic		
2 positions						
	Fixed		D	P9MSVD0●	P9XSVD0N	185370
			I	P9MSVI0●	P9XSVI0N	185371
			H	P9MSVH0●		
	With spring return		D	P9MSVD5●	P9XSVD5N	185373
			I	P9MSVI5●		
			H	P9MSVH1●		
3 positions						
	Fixed		E	P9MSVE0●		
			L	P9MSVL0●		
			U	P9MSVU0●		
			Z, B	P9MSVZ0●	P9XSVZ0N	185379
	With spring return		E	P9MSVE1●		
			L	P9MSVL1●		
			U	P9MSVU1●		
			Z, B	P9MSVZ1●		
			E	P9MSVE5●		
			L	P9MSVL5●		
			U	P9MSVU5●		
			Z, B	P9MSVZ5●		
		E	P9MSVE3●			
		L	P9MSVL3●			
		U	P9MSVU3●			
		Z, B	P9MSVZ3●	P9XSVZ3N	185391	
4 positions						
	Fixed		X	P9MSVX0●	P9XS VX0N	185392
	With spring return		X	P9MSVX5●		
5 positions						
	Fixed		X	P9MSVY0●		
			W	P9MSVW0●		











(1) Electrical diagrams, see F.27

The catalogue numbers in **bold** are available from stock.



Colours round shape	●	black	red	green	yellow	blue
Knobs	●	N	R	V	G	L

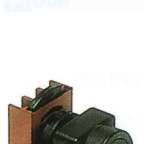

Selector switches with key

	Function ⁽¹⁾	Key removal	Cat. no.			Ref. no.			
			Metal			Plastic			
2 positions									
  	Fixed		D	I	P9MSCD0A▲	P9XSCD0A95	185400	P9SSCD0A95	186400
				II	P9MSCD0E▲	P9XSCD0E95	185401		
				I-II	P9MSCD0K▲	P9XSCD0K95	185402		
			I	0	P9MSCI0C▲				
			I	P9MSCI0E▲					
			0-I	P9MSCI0N▲					
			H	I	P9MSCH0A▲				
			0	P9MSCH0C▲					
			0-I	P9MSCH0H▲					
With spring return		D	I	P9MSCD5A▲	P9XSCD5A95	185409	P9SSCD5A95	186409	
			I	0	P9MSCI5C▲	P9XSCI5C95	185410	P9SSCI5C95	186410
			H	0	P9MSCH1C▲				
3 positions									
  	Fixed		E	I	P9MSCE0A▲				
				0	P9MSCE0C▲				
				II	P9MSCE0E▲				
				I-0	P9MSCE0H▲				
				I-II	P9MSCE0K▲				
				0-II	P9MSCE0N▲				
			L	I	P9MSCLOA▲				
				0	P9MSCLOC▲				
				II	P9MSCLOE▲				
				I-0	P9MSCLOH▲				
				I-II	P9MSCLOK▲				
				0-II	P9MSCLON▲				
	U	I	P9MSCU0A▲						
		0	P9MSCU0C▲						
		II	P9MSCU0E▲						
		I-0	P9MSCU0H▲						
		I-II	P9MSCU0K▲						
		0-II	P9MSCU0N▲						
	Z, B	I	P9MSCZ0A▲	P9XSCZ0A95	185433				
		0	P9MSCZ0C▲	P9XSCZ0C95	185434				
		II	P9MSCZ0E▲	P9XSCZ0E95	185435				
		I-0	P9MSCZ0H▲						
		I-II	P9MSCZ0K▲						
		0-II	P9MSCZ0N▲						
	I-0-II	P9MSCZ0T▲	P9XSCZ0T95	185439	P9SSCZ0T95	186439			

Keys for round metal shape









 	Standard version number	▲	95								
	Standard version with specific number	▲	01	02	03	04	05	10	16	19	55 (Ronis)
	FIAT version number	▲	33	34	37	38	40				
	Colour		yellow	black	red	blue	orange				

(1) Electrical diagrams, see F.27

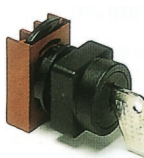
(2) Key for square shape and round plastic shape, only standard version 95

The catalogue numbers in **bold** are available from stock.

Selector switches with key

	Function ⁽¹⁾	Key removal	Cat. no.	Ref. no. see bottom	Cat. no.		Ref. no.		Cat. no.		Ref. no.		
					Metal		Plastic		Plastic ⁽²⁾		Plastic ⁽²⁾		
3 positions													
  	With spring return		E	0	P9MSCE1C▲								
				II	P9MSCE1E▲								
				0-II	P9MSCE1N▲								
			L	0	P9MSCL1C▲								
				II	P9MSCL1E▲								
				0-II	P9MSCL1N▲								
		U	0	P9MSCU1C▲									
		II	P9MSCU1E▲										
		0-II	P9MSCU1N▲										
	Z, B	0	P9MSCZ1C▲										
		II	P9MSCZ1E▲										
		0-II	P9MSCZ1N▲										
		E	I	P9MSCE5A▲									
		0	P9MSCE5C▲										
		I-0	P9MSCE5H▲										
		L	I	P9MSCL5A▲									
		0	P9MSCL5C▲										
		I-0	P9MSCL5H▲										
	U	I	P9MSCU5A▲										
	0	P9MSCU5C▲											
	I-0	P9MSCU5H▲											
	Z, B	I	P9MSCZ5A▲			P9XSCZ5A95	185461	P9SSCZ5A95	186461				
	0	P9MSCZ5C▲			P9XSCZ5C95	185462							
	I-0	P9MSCZ5H▲			P9XSCZ5H95	185463							
	E	0	P9MSCE3C▲										
	L	0	P9MSCL3C▲										
	U	0	P9MSCU3C▲										
	Z, B	0	P9MSCZ3C▲			P9XSCZ3C95	185467	P9SSCZ3C95	186467				
4 positions													
  	Fixed		X	I	P9MSCX0A▲								
				II	P9MSCX0B▲								
				III	P9MSCX0D▲								
				IV	P9MSCX0E▲								
				I-II	P9MSCX0F▲								
				I-III	P9MSCX0J▲								
				I-IV	P9MSCX0K▲								
				II-III	P9MSCX0L▲								
				II-IV	P9MSCX0M▲								
				III-IV	P9MSCX0P▲								
				I-II-III	P9MSCX0R▲								
				I-II-IV	P9MSCX0S▲								
		I-III-IV	P9MSCX0U▲										
		II-III-IV	P9MSCX0V▲										
		I-II-III-IV	P9MSCX0Z▲										
		X	I	P9MSCX5A▲									
		II	P9MSCX5B▲										
		III	P9MSCX5D▲										
		I-II	P9MSCX5F▲										
		I-III	P9MSCX5J▲										
		II-III	P9MSCX5L▲										
		I-II-III	P9MSCX5R▲										

Keys for round metal shape

	Standard version number	▲	95									
	Standard version with specific number	▲	01	02	03	04	05	10	16	19	55 (Ronis)	
	FIAT version number	▲	33	34	37	38	40					
Colour		yellow	black	red	blue	orange						

(1) Electrical diagrams, see F.27

(2) Key for square shape and round plastic shape, only standard version 95





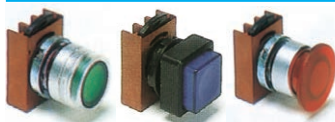
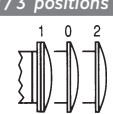

The catalogue numbers in **bold** are available from stock.









Illuminated push-buttons

	Cat. no.	Ref. no. see bottom	Cat. no.	Ref. no. see bottom	Cat. no.	Ref. no. see bottom
						
Standard / Momentary						
With diffused lens:	Flush Raised Recessed		P9MPL●GD P9MPL●SD P9MPL●ED		P9XPL●GD P9XPL●SD	P9SPL●GD P9SPL●SD
Mushroom head / Momentary						
Mushroom head Ø 40mm Mushroom head \square 30mm			P9MEM4●L		P9XEM4●L ⁽¹⁾	P9SEM3RL 186551
Mushroom head / With latch						
Push-pull to release Mushroom head Ø 40mm			P9MET4●L1		P9XET4●L1 ⁽¹⁾	P9SET4RL1 186561
Mushroom head / 3 positions						
With mushroom Ø 40mm						
	1-0 fixed, 2 transient 0 transient, 1-2 fixed		P9MET4●L2 P9MET4●L3		P9XET4RL2	185571

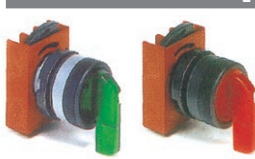
Illuminated selector switches with knob

2 positions		Function ⁽²⁾				
	Fixed		D	P9MSLD0●	P9XSLD0●	P9SSLD0●
3 positions						
	Fixed		Z, B	P9MSLZ0●	P9XSLZ0●	P9SSLZ0●
	With spring return		Z, B	P9MSLZ1●		
			Z, B	P9MSLZ5●		
			Z, B	P9MSLZ3●		

Illuminated selector switches with lever







2 positions		Function ⁽²⁾				
	Fixed		D	P9MSAD0●		
3 positions						
	Fixed		Z, B	P9MSAZ0●		
	With spring return		Z, B	P9MSAZ1●		
			Z, B	P9MSAZ5●		
			Z, B	P9MSAZ3●		

(1) Color R, V or G
(2) Electrical diagrams, see F.27





The catalogue numbers in **bold** are available from stock.

Colours		red	green	yellow	orange	blue	white	clear
Lens	●	R	V	G	A	L	B	I
Mushroom heads	●	R	V	G	A	L	B	I
Knob/lever	●	R	V	G	A	L	B	I



Selector push-buttons (black coloured)

	Function ⁽¹⁾	Cat. no.	Ref. no.	Metal		Plastic	
							
2 positions							
	Fixed 	201	P9MPS21G	184690			
		231	P9MPS22G	184691			
		235	P9MPS23G	184692			
3 positions							
	Fixed 	301	P9MPS34G	184693			
		323	P9MPS35G	184694			

Toggle switches (black coloured)

	Function ⁽²⁾	Cat. no.	Ref. no.	Plastic	
2 positions					
	Fixed position 	D	P9MCD	184695	P9XCD 185695 P9SCD 186695
3 positions					
	Fixed position Transient to zero from one position 	B	P9MCB	184696	
		B	P9MCC	184697	

Rubber protective caps (IP66)

Description	Cat. no.	Ref. no. see bottom	Plastic	
				
Standard flush push-buttons	coloured (nitrilic rubber)	080CP●		P9ASCG●
	clear (silicon rubber)	080CPT	170198	P9ASCGT 170790
Raised push buttons	clear (silicon rubber)	P9ARCST	187490	P9ASCST 187791

(1) Electrical diagrams, see F.27

The catalogue numbers in **bold** are available from stock.



Emergency lever



	Cat. no.	Ref. no.	Cat. no.	Ref. no.	Cat. no.	Ref. no.
	Metal		Plastic		Plastic	
Red lever	P9MWR	184770				

Reset push-button



White symbol on blue background	P9MRG	184771	P9XRG	185771		
---------------------------------	-------	--------	-------	--------	--	--

Potentiometer operator (potentiometer not included)



Black knob	P9MZ	184772	P9XZ	185772	P9SZ	186772
------------	------	--------	------	--------	------	--------

Buzzer













Black coloured	24V		P9XBD	185773	P9SBD	186773
Bitonal sound	110-240V		P9XBM	185774	P9SBM	186774
Full voltage AC/DC						
Frequency: 2kHz						
Sound intensity: 80dB at 1m						
Consumption: 3 to 9mA						



The catalogue numbers in **bold** are available from stock.

Colours		black	red	green	yellow	orange	blue	white	clear
Mushroom heads	●	N	R	V	G	-	L	-	-
Knobs/lever	●	N	R	V	G	-	L	-	-
Lenses		-	R	V	G	A	L	B	I
Protective caps	●	N	R	V	G	-	-	-	-

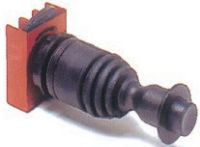
Joysticks (black coloured)

			Cat. no.	Ref. no.	Cat. no.	Ref. no.	
			Metal		Plastic		
							
2 positions + central zero position⁽¹⁾							
	Without interlock		fixed positions	P9MMN2F	184700	P9XMN2F	185700
			transient positions	P9MMN2T	184701	P9XMN2T	185701
			1 transient - 3 fixed positions	P9MMN2A	184702		
			1 fixed - 3 transient positions	P9MMN2B	184703		
	With interlock		fixed positions	P9MMB2F	184710	P9XMB2F	185710
			transient positions	P9MMB2T	184711	P9XMB2T	185711
			1 transient - 3 fixed positions	P9MMB2A	184712	P9XMB2A	185712
			1 fixed - 3 transient positions	P9MMB2B	184713	P9XMB2B	185713
4 positions + central zero position⁽¹⁾							
	Without interlock		fixed positions	P9MMN4F	184720	P9XMN4F	185720
			transient positions	P9MMN4T	184721	P9XMN4T	185721
	With interlock		fixed positions	P9MMB4F	184740	P9XMB4F	185740
			transient positions	P9MMB4T	184741	P9XMB4T	185741

Spare boots for joysticks











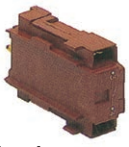













 (a)	 (b)	Standard rubber boot for joystick	(a)	P9ARSCMN	188043
		Standard rubber boot for joystick with interlock	(a)	P9ARSCMB	188044
		Silicone boot for joystick	(b)	P9ARSGMN	187495
		Silicone boot for joystick with interlock	(b)	P9ARSGMB	187496

(1) Electrical diagrams, see F.27

The catalogue numbers in **bold** are available from stock.















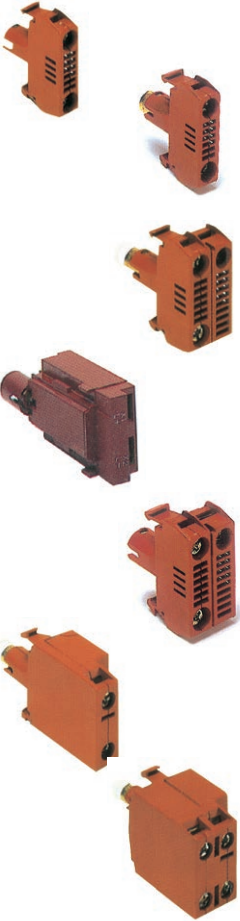



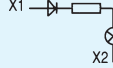











Contact blocks

				Cat. no.	Ref. no.	
 <p>Logic Reed A new range of LOGIC REED contact blocks with faston terminals for use with power lower than 12V - 5mA.</p> <p>(Not for emergency stop)</p>	Contact type	NC NO		P9B01FH P9B10FH	187014 187015	
	Rated voltage	AC2 to 120V max. DC2 to 30V max.				
	Rated current	AC/DC - 0.001 to 0.15A max.				
	Rated power	AC - 8VA max. DC - 4.5W max.				
	Minimum centerline distance	30x 32mm				
	Mounting on operators	through specific bayonet flange adaptor			P9ACFSM	
	Full voltage power supply				P9PDHF	
<hr/>						
<p>With screw</p>  <p>min. 1 of 22 AWG (0.32mm²) max. 2 of 12 AWG (3.3mm²)</p>     				<p>Contact type</p> 	Cat. no.	Ref. no.
		 	NC+NO	P9B11VN	187000	
		 	NC+NC	P9B02VN	187008	
			NO+NO	P9B20VN	187009	
		 	NC	P9B01VN	187001	
			NO	P9B10VN	187002	
		 	NC late opening	P9B01VR	187003	
			NO early closing	P9B10VA	187004	
	<hr/>					
	<p>Faston</p>  <p>1x(6.35x0.8mm) 2x(2.8x0.8mm)</p> 					
		 	NC	P9B01FN	187012	
		NO	P9B10FN	187013		
<hr/>						
 <p>Terminal adapter printed circuit board adapter</p>				P9ACA6	188804	

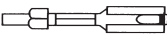
The catalogue numbers in **bold** are available from stock.

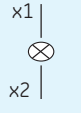
Power supplies

With screw	Position on flange	Contact type	Cat. no.	Ref. no.	
 min. 1 of 22 AWG (0.32mm ²) max. 2 of 12 AWG (3.3mm ²)	3 2 1 				
			Full voltage ≙ IEC: BA9S max 380V-2W not included UL-CSA: BA9S max 250V-2W not included	P9PDNV0 187020	
			Logic Reed fullvoltage for low power	P9PDHF 187056	
			Long life 110/120V ≙ BA9S 130V-2W included	P9PRLVJ 187021	
			Resistor + Diode 220/240V ~ BA9S 130V-2W included	P9PRDVN 187022	
			Resistor 110/120V ≙ BA9S 60V-1.2W included	P9PRNVJ 187023	
			220/240V ≙ BA9S 130V-2W included	P9PRNVN 187024	
			Resistor ENEL version BA9S 48V-2W included 110V ≙	P9PREVJ 187025	
			125/127V ≙	P9PREVL 187026	
			UL-CSA: BA9S max 250V-2W not included Test full voltage (1) ≙ IEC: BA9S max 380V-2W not included	P9PDTV0 187027	
			Test resistor (1) 220/240V ≙ BA9S 130V-2W included	P9PRTVN 187028	
			Transformer 50/60Hz BA9S 6V-1.5W included	P9PTNV ♦ see bottom	
			Multifunction (2) full voltage 24V ≙ BA9S 24V-2W included	P9PDMVD 187040	
		Multifunction (2) full voltage 110V ≙ BA9S 130V-2W included	P9PDMVJ 187041		
		Multifunction (2) Transformer 50/60Hz BA9S 6V-0.6W included	P9PTMV ◇ see bottom		
 Faston 1x(6.35x0.8mm) 2x(2.8x0.8mm)	 X1 X2		Full voltage IEC:BA9S max 380V-2W not included UL-CSA: BA9S max 250V-2W not included	P9PDNF0 187055	
 Integrated LED	 x1 x2		Standard light	24V AC/DC 120V AC 230V AC	P9PLNV ● see bottom P9PLNVJ ● P9PLNVN ●
			Flashing light	24V AC/DC 120V AC 230V AC	P9PLFV ● see bottom P9PLFVJ ● P9PLFVN ●

The catalogue numbers in **bold** are available from stock.

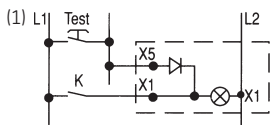





(2) Y1 Y2 Do not connect for flashing light
 Y1 Y2 Link to external contact in order to have steady or flashing light
 L C C closed = Steady light
 L C C open = Flashing light



Colours	red	green	yellow	orange	blue	white
LED	● R	● V	● G	● A	● L	● B
Voltage	110-120	220-250	400	415-440	480-500	
♦	J	N	U	W	Y	
◇	J	N	U	-	-	



Base mounting - Contact blocks

With screw			Contact type	Cat. no.	Ref. no.
 min. 1 of 22 AWG (0.32mm ²) max. 2 of 12 AWG (3.3mm ²)		 1 2	NC	P9B01BN	187017
			 3 4	NO	P9B10BN

Base mounting - Power supplies

With screw		Position on flange	Bulb power supply	Cat. no.	Ref. no.
 min. 1 of 22 AWG (0.32mm ²) max. 2 of 12 AWG (3.3mm ²)		3 2 1	Full voltage ≅ IEC: BA9S max 380V-2W not included UL-CSA: BA9S max 250V-2W not included		187070
					P9PDNB0

Intro

A

B

C

D

E

F

G

H

I

X



Diagrams

Selector switches

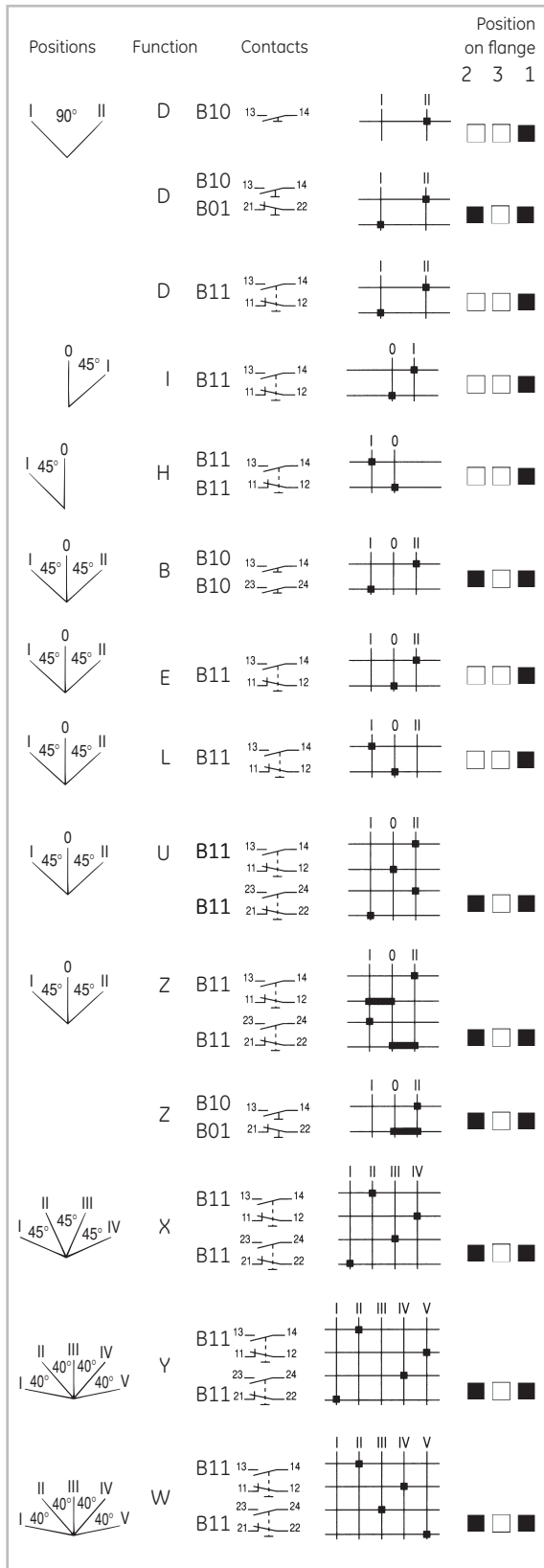

Selector push-buttons

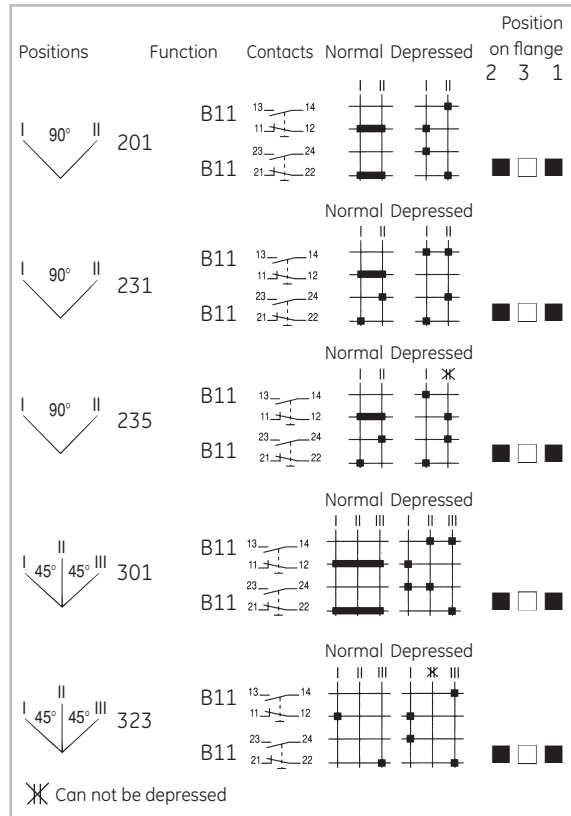

Joysticks

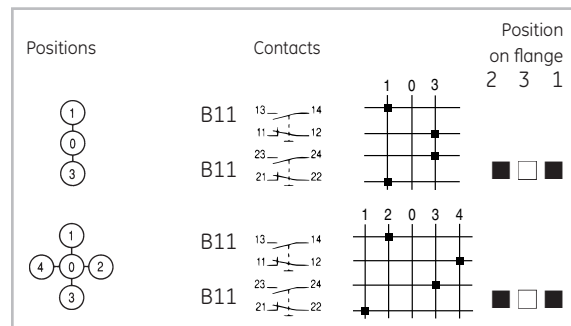

Toggle switches

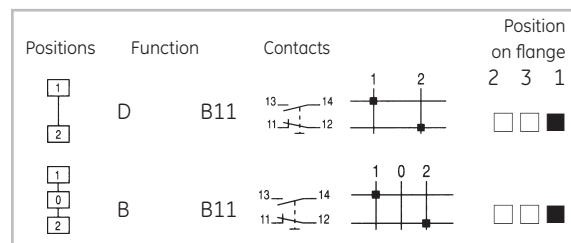

Mushroom head push-buttons 3 pos.

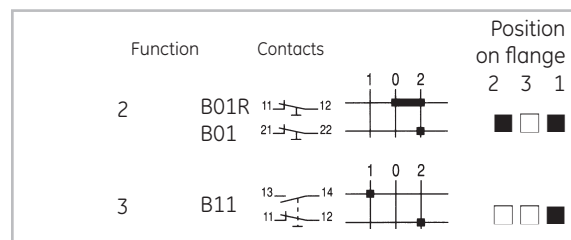

Base mounting

Intro

A

B

C

D

E

F

G

H

I

X



Empty box for DIN-rail application (Light grey coloured RAL 7035)



Diagram	Cat. no.	Ref. no.
1	P9EPEM	189200
- Up to 3 base mounting contact blocks and power supplies - 1 hole P9EPEM 189200 - Can be used in modular cabinet - 36mm width - Double protection		

Push-button stations in thermoplastic (Light grey coloured RAL 7035)

For panel and base mounting

- IP66 according to IEC529, EN 60529
- Engineered thermoplastic covers, bases and screws
- Self extinguishing Class V0, according to UL 94
- Rust resistant (4X according to UL 508)
- Total insulation with all thermoplastic operators
- Contact blocks and power supplies for both base and front mounting

For panel and base mounting



Cover with holes
Knockouts conduit entry

Number of holes	Cat. no.	Ref. no.
1 (yellow cover)	P9EPEG1	189000
1	P9EPE01	189001
2	P9EPE02	189002
2 (yellow cover)	P9EPEG2	189006
3	P9EPE03	189003
4	P9EPE04	189004
6	P9EPE06	189005

For panel mounting

Accessories

Write-on plates
Bilaminated, self adhesive, 20x20mm
Black background
engravable for white texts



Earth terminal clamp

Description	Symbols	Cat. no.	Ref. no.
Without text		P9AELN	189030
Text in English (1) START		P9AELN202	189031
STOP		P9AELN201	189032
FORWARD		P9AELN214	189033
REVERSE		P9AELN215	189034
CLOSE		P9AELN205	189035
OPEN		P9AELN206	189036
UP		P9AELN204	189037
DOWN		P9AELN203	189038
LEFT		P9AELN222	189152
RIGHT		P9AELN224	189154
	→	P9AELN006	189041
	I	P9AELN028	189042
	O	P9AELN029	189043
	II	P9AELN035	189044
	III	P9AELN038	189045
	O-I	P9AELN039	189046
	I-O-II	P9AELN042	189047
		P9AEMT	189029

The catalogue numbers in **bold** are available from stock.

(1) Other languages on request

Push-button stations in thermoplastic (continued)

Equipped versions		Operators	Colour	Diagram	Nameplate	Cat. no.	Ref. no.
 	One unit	Flush push-button	green		I	P9EPA01Y02	189010
		Flush push-button	white		I	P9EPA01Y03	189011
		Emergency push-button with latch according to EN418 (yellow cover)	red		0	P9EPAG1Y0N	189007
		Emergency push-button with latch & status indicator according to EN418 (yellow cover)	red		0	P9EPAG1Y01W	189008
		Emergency push-button with latch according to EN418 - key to release (yellow cover)	red		0	P9EPAG1Y06N	189009

Equipped versions		Operators	Colour	Diagram	Nameplate	Cat. no.	Ref. no.
	Two units	Flush push-buttons	green		I	P9EPA02Y01	189016
		Flush push-buttons	red		0		

	Three units	Full voltage pilot light max 380V-2W not included	BA9S	white		blank	P9EPA03Y01	189018
		Flush push-buttons		green		I		
		Flush push-buttons		red		0		
		Flush push-buttons		black		↑	P9EPA03Y05	189022
		Flush push-buttons		red		0		
		Flush push-buttons		black		↓		

Equipped boxes

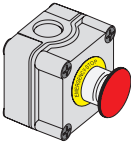
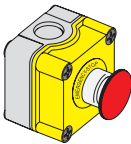
Specially enclosures to use for shaft lifts (other versions, please contact us)		Composition	Individual operators	Cat. no.	Ref. no.	Pack
 	One operator	Thermoplastic box. 1 element	P9EPE01	P9EPC01X00	215432	1
		Emergency push button mushroom head Ø 40, push-pull to release	P9XET4RN1			
		1NC contact block	P9B01VN			
		1NO contact block	P9B10VN			
		Nameplate with inscription "EMERGENCY-STOP"	080XTGR02			
		PG16 packing gland				
		Thermoplastic box. Yellow cover. 1 element	P9EPEG1	P9EPC01X01	215433	1
		Emergency push-button mushroom head Ø 40, push-twist to release	P9XER4RN			
		1NC contact block	P9B01VN			
		Nameplate with inscription "EMERGENCY-STOP"	080XTGR02			

The catalogue numbers in **bold** are available from stock.

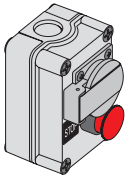
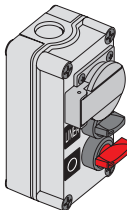
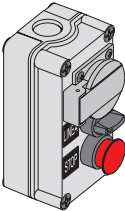
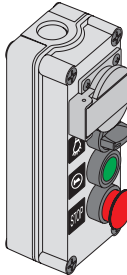

Equipped boxes (continued)

		Composition	Individual operators	Cat. no.	Ref. no.	Pack
	Two operators	Specially enclosures to use for shaft lifts (other versions, please contact us)				
		Thermoplastic box, 2 elements Emergency push button mushroom head Ø 28, push-twist to release 1NC contact block Nameplate with inscription "STOP" 16A Schuko socket-outlet with cover	P9EPE02 P9XER3RN P9B01VN P9AELN201	P9EPL02X01	189136	1
	Three operators	Thermoplastic box, 3 elements Selector switch, 2 positions, with black knob 1NC contact block 1NO contact block Nameplate with inscription "LINEA" Selector switch, 2 positions, with red lever 1NO contact block Nameplate with inscription "O-I" 16A Schuko socket-outlet with cover	P9EPE03 P9XSMD0N P9B01VN P9B10VN P9AELN523 P9XSVD0R P9B10VN P9AELN039	P9EPL03X01	189138	1
		Thermoplastic box, 3 elements Selector switch, 2 positions, with black knob 1NC contact block 1NO contact block Nameplate with inscription "LINEA" Emergency push-button mushroom head Ø 28, push-twist to release 1NC contact block Nameplate with inscription "STOP" 16A Schuko socket-outlet with cover	P9EPE03 P9XSMD0N P9B01VN P8B10VN P9AELN523 P9XER3RN P9B01VN P9AELN201	P9EPL03X02	189139	1
	Four operators	Thermoplastic box, 4 elements Selector switch, 2 positions, with black knob 1NC contact block 1NO contact block Nameplate with "Light" symbol Standard/momentary push button with flush cap, green 1NO contact block Nameplate with "Bell" symbol Emergency push-button mushroom head Ø 28, push-twist to release 1NC contact block Nameplate with inscription "STOP" 16A Schuko socket-outlet with cover	P9EPE04 P9XSMD0N P9B01VN P9B10VN P9AELN100 P9XPNVG P9B10VN P9XER3RN P9B01VN P9AELN201	P9EPL04X01	189141	1

The catalogue numbers in **bold** are available from stock.















Push-button stations in aluminium (Grey coloured RAL 7012)

For panel mounting		Protection	Number of holes	Type	Cat. no.	Ref. no.
	Cover with holes with conduit entry	IP66 (according to IEC 529, EN 60529)	1	1	080SP1	170801
			1	1M ⁽¹⁾	080SP1M	170831
			2	2	080SP2	170802
			2	2M ⁽¹⁾	080SP2M	170832
			3	3	080SP3	170803
			4	4	080SP4	170804
			4	4M ⁽¹⁾	080SP4M	170834
			6	6	080SP6	170806
			8	8	080SP8	170807
			12	12	080SP12	170808
			18	18	080SP18	170809
			24	24	080SP24	170810
			35	35	080SP35	170811
				Cover with holes without conduit entry	IP66 (according to IEC 529, EN 60529)	1
1	1M ⁽¹⁾	080SP1MSFE				170839
2	2	080SP2SFE				170842
2	2M ⁽¹⁾	080SP2MSFE				170845
3	3	080SP3SFE				170848
4	4	080SP4SFE				170850
4	4M ⁽¹⁾	080SP4MSFE				170851
6	6	080SP6SFE				170852
8	8	080SP8SFE				170854
12	12	080SP12SFE				170857
18	18	080SP18SFE				170860
24	24	080SP24SFE				170862
35	35	080SP35SFE				170864
	Cover without holes with conduit entry	IP66 (according to IEC 529, EN 60529)				1
			1M ⁽¹⁾	080SP1MSFC	170838	
			2	080SP2SFC	170841	
			2M ⁽¹⁾	080SP2MSFC	170844	
			3	080SP3SFC	170847	
			4	080SP2SFC	170841	
			4M ⁽¹⁾	080SP2MSFC	170844	
			6	080SP3SFC	170847	
			8	080SP8SFC	170853	
			12	080SP12SFC	170856	
			18	080SP18SFC	170859	
			24	080SP18SFC	170859	
			35	080SP35SFC	170863	
				Cover without holes without conduit entry	IP66 (according to IEC 529, EN 60529)	1
1M ⁽¹⁾	080SP1MSF	170840				
2	080SP2SF	170843				
2M ⁽¹⁾	080SP2MSF	170846				
3	080SP3SF	170849				
4	080SP2SF	170843				
4M ⁽¹⁾	080SP2MSF	170846				
6	080SP3SF	170849				
8	080SP8SF	170855				
12	080SP12SF	170858				
18	080SP18SF	170861				
24	080SP18SF	170861				
35	080SP35SF	170865				
(1) With deep socle						
Accessories						
Description					Cat. no.	Ref. no.
Kit of two hinges for types 18, 24, 35 with holes					080KCSP	170883

The catalogue numbers in **bold** are available from stock.

Overall dimensions, see F.43

Caps for standard push-buttons

















	Colour	Cat. no.	Ref. no.	Cat. no.	Ref. no.	Cat. no.	Ref. no.	Cat. no.	Ref. no.
		Flush and recessed		Raised		Flush		Raised	
Neutral									
		P9ARBG ●	18710 ■	P9ARBS ●	18720 ■	P9ASBG ●	18750 ■	P9ASBS ●	18760 ■
With symbols ⁽¹⁾									
Stop 	Black	P9ARBGN 029	187150	P9ARBSN 029	187250	P9ASBGN 029	187550	P9ASBSN 029	187650
	Red	P9ARBGR 029	187110	P9ARBSR 029	187210	P9ASBGR 029	187510	P9ASBSR 029	187610
Start 	Black	P9ARBGN 028	187111	P9ARBSN 028	187211	P9ASBGN 028	187511	P9ASBSN 028	187611
	Green	P9ARBGV 028	187112	P9ARBSV 028	187212	P9ASBGV 028	187512	P9ASBSV 028	187612
	White	P9ARBGB 028	187151	P9ARBSB 028	187251	P9ASBGB 028	187551	P9ASBSB 028	187651
Continuous rectilinear motion 	Black	P9ARBGN 006	187117	P9ARBSN 006	187217	P9ASBGN 006	187517	P9ASBSN 006	187617
	Green	P9ARBGV 006	187118	P9ARBSV 006	187218	P9ASBGV 006	187518	P9ASBSV 006	187618
	White	P9ARBGB 006	187152	P9ARBSB 006	187252	P9ASBGB 006	187552	P9ASBSB 006	187652
Increase 	Black	P9ARBGN 017	187125						
Decrease 	Black	P9ARBGN 018	187127						
Reset 	Blue	P9ARBGL 037	187143			P9ASBGL 037	187543	P9ASBSL 037	187643
Stop/Reset 	Red	P9ARBGR 036	187144						
Test 	Black	P9ARBGN 030	187145	P9ARBSN 030	187245	P9ASBGN 030	187545	P9ASBSN 030	187645
	Green	P9ARBGV 030	187146	P9ARBSV 030	187246	P9ASBGV 030	187546	P9ASBSV 030	187646
Stop 	Red	P9ARBGR 201	187147	P9ARBSR 201	187247	P9ASBGR 201	187547	P9ASBSR 201	187647
Start 	Black	P9ARBGN 202	187148	P9ARBSN 202	187248	P9ASBGN 202	187548	P9ASBSN 202	187648
	Green	P9ARBGV 202	187149	P9ARBSV 202	187249	P9ASBGV 202	187549	P9ASBSV 202	187649
	White	P9ARBGB 202	188909	P9ARBSB 202	188978	P9ASBGB 202	189859	P9ASBSB 202	189928

(1) Other symbols on request

The catalogue numbers in **bold** are available from stock.

Colours		black	red	green	yellow	brown	blue	white	grey
Caps	●	N	R	V	G	M	L	B	H
	■	0	1	1	3	4	6	7	8

Diffusers/insert for illuminated units

		Cat. no.	Ref. no.	Cat. no.	Ref. no.	Cat. no.	Ref. no.
		For pilot lights		For illuminated push buttons		For pilot lights and illuminated push buttons	
							
Neutral		P9ARDLS	187300	P9ARDPL	187350	080QDF	173220
With symbols ⁽¹⁾	on white background						
Stop		P9ARDLS029	187301	P9ARDPL029	187351	080QDF029	187701
Start		P9ARDLS028	187302	P9ARDPL028	187352	080QDF028	187702
Continuous rectilinear motion		P9ARDLS006	187305	P9ARDPL006	187355	080QDF006	187705
Increase		P9ARDLS017	187309	P9ARDPL017	187359	080QDF017	187709
Decrease		P9ARDLS018	187310	P9ARDPL018	187360	080QDF018	187710
Auto cycle		P9ARDLS026	187311	P9ARDPL026	187361	080QDF026	187711
Manual		P9ARDLS027	187312	P9ARDPL027	187362	080QDF027	185788
Locking		P9ARDLS031	187313	P9ARDPL031	187363	080QDF031	187713
Releasing		P9ARDLS032	187314	P9ARDPL032	187364	080QDF032	187714
Coolant		P9ARDLS001	187315	P9ARDPL001	187365	080QDF001	187715
Light		P9ARDLS002	187316	P9ARDPL002	187366	080QDF002	187716
Test		P9ARDLS030	187318	P9ARDPL030	187368	080QDF030	185789
Stop		P9ARDLS201	187319	P9ARDPL201	187369	080QDF201	187719
Start		P9ARDLS202	187320	P9ARDPL202	187370	080QDF202	187720

(1) Other symbols on request

The catalogue numbers in **bold** are available from stock.





Common accessories



	Plugs	Description	Cat. no.	Ref. no.	Cat. no.	Ref. no.
			Plastic		Plastic	
		Round	P9ARHPR	187491		
		Square 30x30mm			P9ASHP3	187792
		Rectangular 30x50mm			P9ASHP5	187793
	Protections					
		Collar for mushroom head push-buttons Ø 40mm.	P9ARRE4	187492		
		Protection cover padlockable for standard push-buttons, illuminated push-buttons, selector switches, illuminated selector switches with knob.	P9ACRCL	187840	P9ACRCL	187840
	Flanges					
		With three positions	P9ACFS3	187841	P9ACFS3	187841
		With five positions	P9ACFS5	187842	P9ACFS5	187842
		With two positions	P9ACFSM	187846	P9ACFSM	187846
	Adapter screw plug-in terminal	Only for Logic Reed contact blocks and power supplies	P9ACAFV	187847	P9ACAFV	187847
	Adapter	Gives round control and signalling units a square appearance. Made in black thermoplastic. Can be used with nameplate for square operators P9ASTBS (see F.38). Excluded for mushroom flush buttons with positive break and types with 3 positions.	P9ARSN1	188805		
						
		Push-on/push off	Device for standard push-buttons and illuminated push-buttons. To be added only to single pole contact blocks. The NO-contacts must be early closing types.	P9ACDPP	187843	P9ACDPP
						
		Extended screw	For reset push-buttons (setting min. 80, max. 170mm)	P9ACVLR	187844	P9ACVLR
						
		Central contact driving plug	For standard momentary push-buttons and momentary mushroom head push-buttons.			P9ASHAC
		Tools				
		Locking ring wrench	P9ACWAF	187845	P9ACWAF	187845
		Bulb extractor	080ESL	170212	080ESL	170212
		Extractor for caps and lenses			P9ASEBG	187795

The catalogue numbers in **bold** are available from stock.

Spare keys



Description	Cat. no.	Ref. no.	
			Plastic
			
Standard version	Code		
	3095	077C3095	173095
	9901	077C9901	179901
	9902	077C9902	179902
	9903	077C9903	179903
	9904	077C9904	179904
	9905	077C9905	179905
	9910	077C9910	179910
	9916	077C9916	179916
	9919	077C9919	179919
	3353	077C3353	173353
	(Ronis) 455	077CR455	173455
FIAT version	Colour	Code	
	yellow	73033	077CF73033 173033
	black	73034	077CF73034 173034
	red	73037	077CF73037 173037
	blue	73038	077CF73038 173038
	orange	73040	077CF73040 173040

Bulbs BA9s

Description	Cat. no.	Ref. no.	
			Plastic
			
Filament type	Vn	W	
	6	0.6	BA9S606 187850
	6	1.5	BA9S615 187851
	12	2.0	BA9S122 187852
	24	2.0	BA9S242 187853
	30	2.1	BA9S30 187854
	48	2.0	BA9S48 187855
	60	1.2	BA9S6012 187856
	130	2.0	BA9S130 187857
	220	2.0	BA9S220 187868
Neon type	110	0.11	BA9SN110 187860
	220	0.33	BA9SN220 187861
MultiLED	VN AC/DC ±10%		
	6		BA9S6LED•
	12		BA9S12LED•
	24		BA9S24LED•
	48		BA9S48LED•
	60		BA9S60LED 187191
	110		BA9S110LED•
	130		BA9S130LED 187190
	(AC) 230		BA9S230LED•

Colours	●	red	green	yellow	blue	white
		R	V	G	L	B

Insert holders

Description	Cat. no.	Ref. no.	Cat. no.	Ref. no.
				
Supplied with neutral insert engravable on both sides or transparent.				
Standard 30 x 50mm	Background black/red, white text	P9ARTBS	188000	P9ASTBS 188010
	Background white, black text	P9ARTWS	188005	P9ASTWS 188011
	Transparent	P9ARTTS	188012	P9ASTTS 188014
Extended 45 x 50mm	Background black/red, white text	P9ARTBM	188001	
	Background white, black text	P9ARTWM	188008	
	Transparent	P9ARTTM	188013	

The catalogue numbers in **bold** are available from stock.

Intro

A

B

C

D

E

F

G

H

I

X



Rectangular inserts

For insert holders 30x50mm							
Neutral			Aluminium English ⁽¹⁾				
Description	Cat. no.	Ref. no.	Description	Cat. no.	Ref. no.		
black/red background	P9ACPBS	188015					
white background	P9ACPWS	188017					
transparent	P9ACPTS	188018					
English ⁽¹⁾			Aluminium English ⁽¹⁾				
START	Black background	START	P9ACPBS202	188202	Without inscription	P9ARTAPN	116099
		STOP	P9ACPBS201	188201	O - I	P9ARTAPN039	116140
		REVERSE	P9ACPBS215	188215	I O II	P9ARTAPN042	116141
		CLOSE	P9ACPBS205	188205	ON	P9ARTAPN212	116147
		OPEN	P9ACPBS206	188206	RESET	P9ARTAPN291	116150
		UP	P9ACPBS204	188204	I II	P9ARTAPN040	116991
		DOWN	P9ACPBS203	188203	I	P9ARTAPN028	118846
		LEFT	P9ACPBS222	188222	STOP	P9ARTAPN201	116143
		RIGHT	P9ACPBS224	188224	START	P9ARTAPN202	116144
		FAST	P9ACPBS208	188208	OPEN	P9ARTAPN206	116145
		SLOW	P9ACPBS207	188207	OF	P9ARTAPN213	116148
		OPEN-CLOSE	P9ACPBS234	188234			
		HAND-AUTO	P9ACPBS243	188243			
	MARCHE		STOP-START	P9ACPBS232	188232		
		FORWARD-REVERSE	P9ACPBS231	188231			
		OFF-ON	P9ACPBS233	188233			
		AUTO-OFF-HAND	P9ACPBS258	188258			
		FORWARD-O-REVERSE	P9ACPBS239	188239			
		O - I	P9ACPBS039	188030			
For insert holders 45x50mm							
Neutral							
black/red background, white text	P9ARPB	188002					
white background, black text	P9ARPW	188028					
transparent	P9ARPT	188019					

Round plates for emergency

		Diameter 59mm			Diameter 78mm		
		Description	Cat. no.	Ref. no.	Description	Cat. no.	Ref. no.
Without text	yellow background		080XTGR	179514	black background	080XTG8	179515
	With text	yellow background			black background		
	EMERGENZA	080XTGR01	179525	EMERGENZA	080XTG801	179535	
	EMERGENCY STOP	080XTGR02	179526	EMERGENCY STOP	080XTG802	179536	
	ARRET D'URGENCE	080XTGR03	179510	ARRET D'URGENCE	080XTG803	179511	
	NOT - AUS	080XTGR04	179527	NOT - AUS	080XTG804	179537	
	NOODSTOP	080XTGR05	179528	NOODSTOP	080XTG805	179538	
	PARO EMERGENCIA	080XTGR06	179529	PARO EMERGENCIA	080XTG806	179539	
	NOTSTOP	080XTGR07	179530	NOTSTOP	080XTG807	179540	
	PARAGEM EMERGENCIA	080XTGR08	179531	PARAGEM EMERGENCIA	080XTG808	179541	

Neutral plate

		Description	Cat. no.	Ref. no.
	Snap-on system	For identification of contact blocks and power supplies	P9ACPIU	188016

Adapter ring

		Description	Cat. no.	Ref. no.
		Adapter ring for 30mm hole to mount P9 22mm in a 30mm hole	P9ARAM32	188801

The catalogue numbers in **bold** are available from stock.

(1) Other languages on request.

Everything is under control

Dimensional drawings

Round operators - Push-buttons

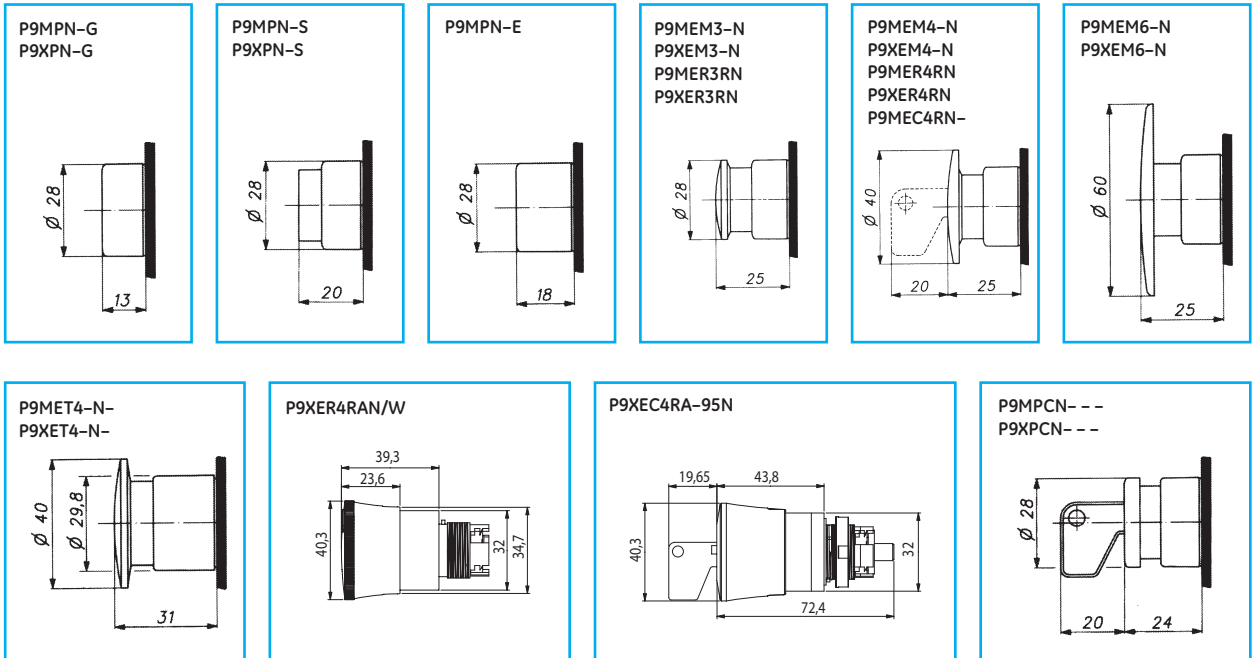

Round operators - Selector switches

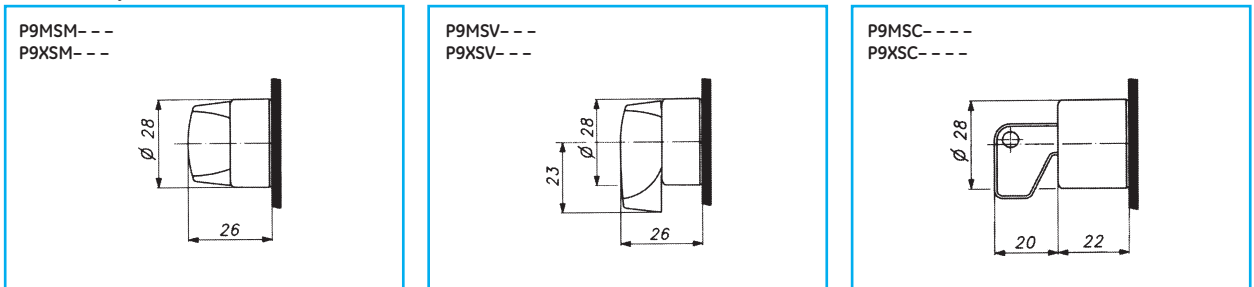

Round operators - Illuminated push-buttons and selector switches

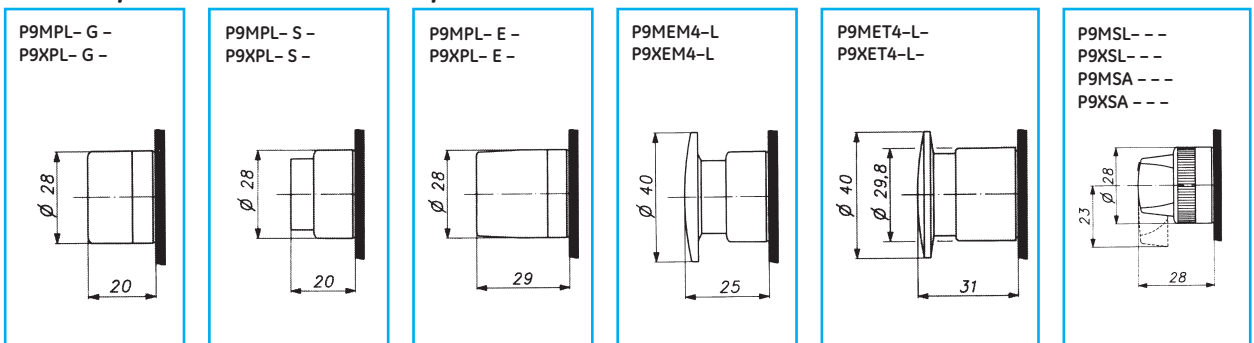

Round operators - Pilot lights

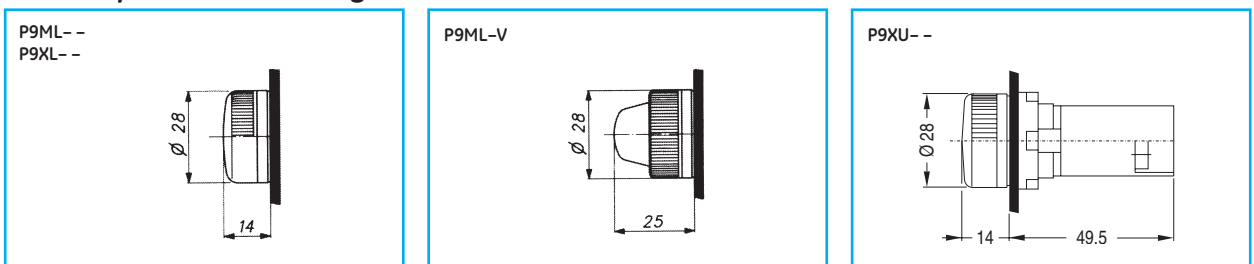

Dimensions in mm (inch = mm x 0.03937) - Weight in kg (lb = kg x 2.2046)



Round operators - Other devices

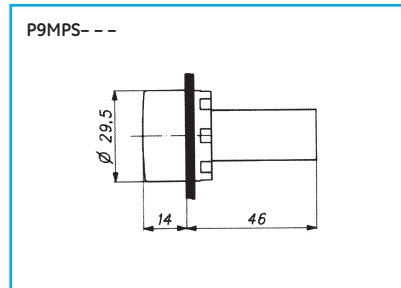
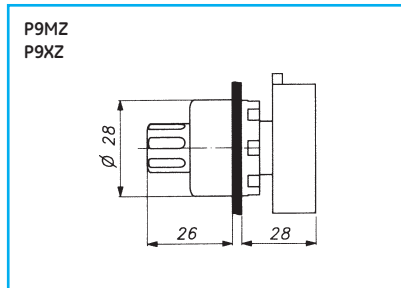
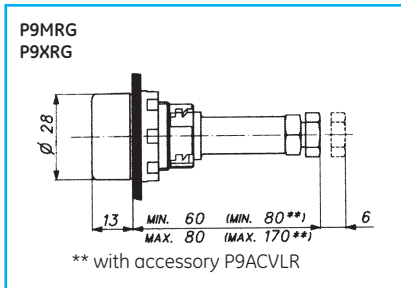
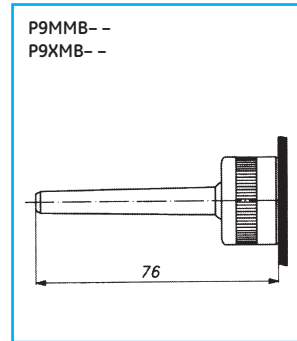
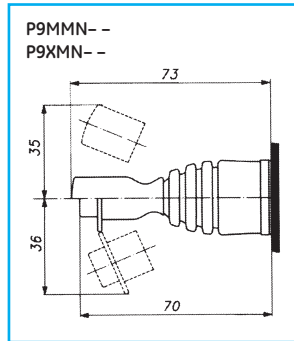
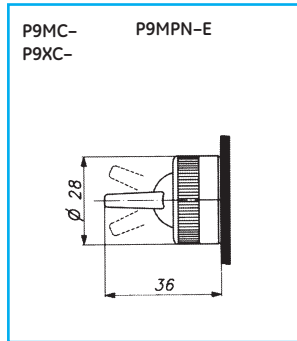
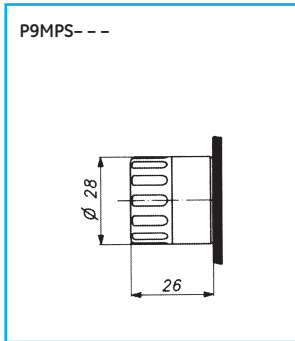

Square operators - Push-buttons

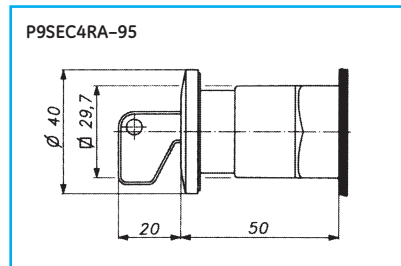
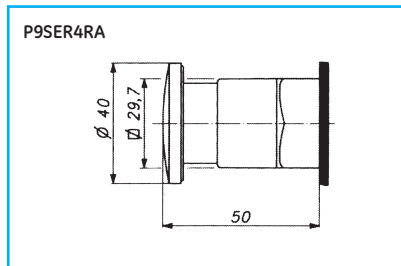
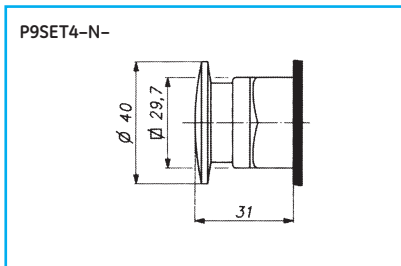
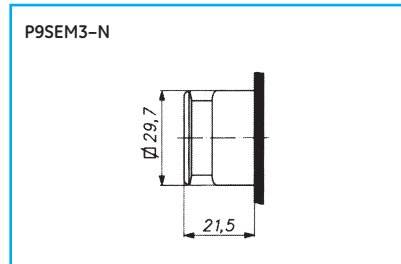
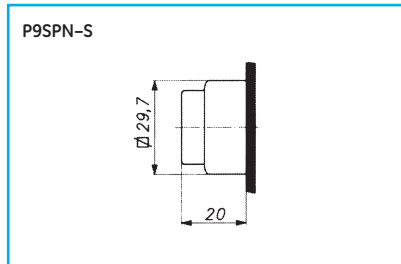
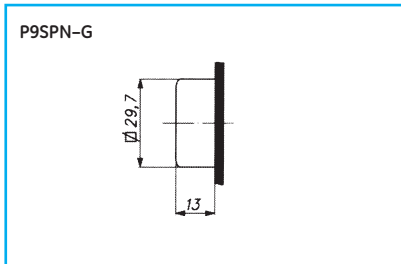

Square operators - Double function push-buttons

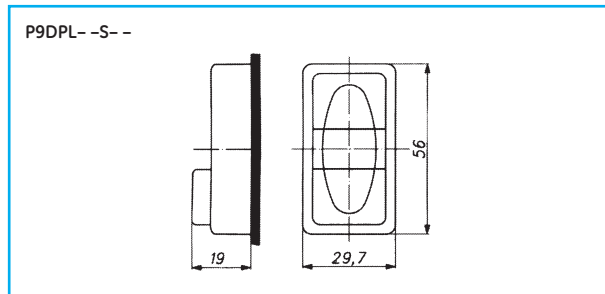
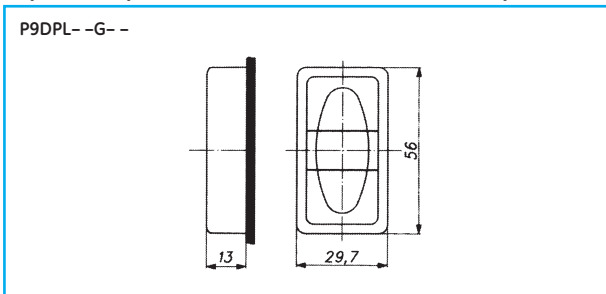

Dimensions in mm (inch = mm x 0.03937) - Weight in kg (lb = kg x 2.2046)



Dimensional drawings

Square operators - Selector switches

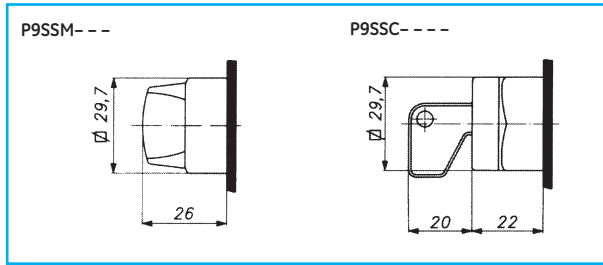

Square operators - Pilot lights

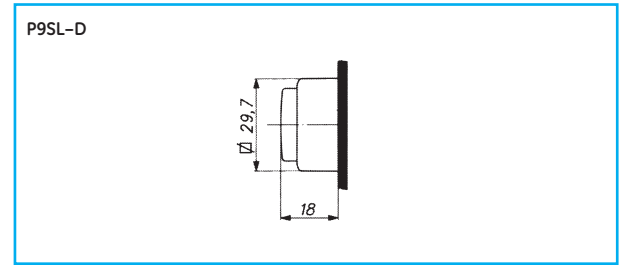

Square operators - Illuminated push-buttons and selector switches

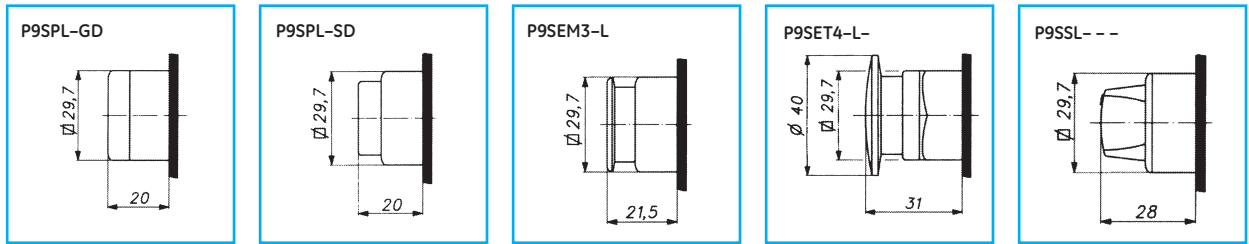

Square operators - Other devices

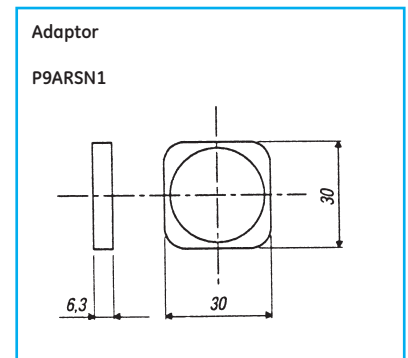
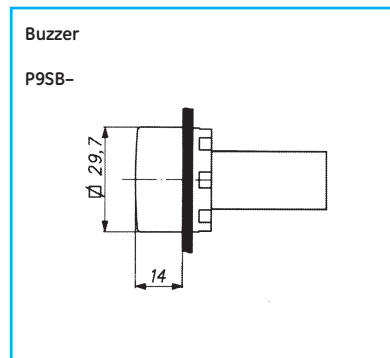
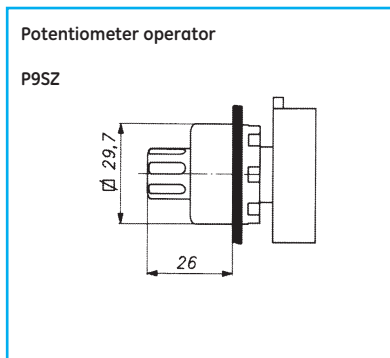
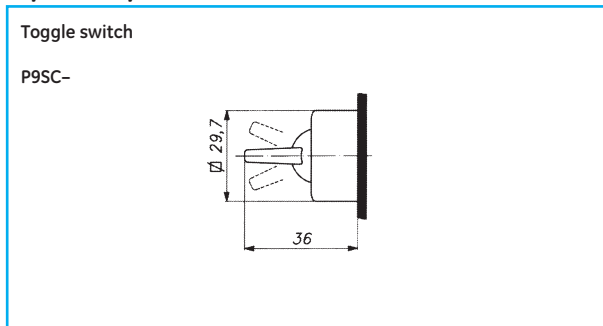

Dimensions in mm (inch = mm x 0.03937) - Weight in kg (lb = kg x 2.2046)



Contact blocks

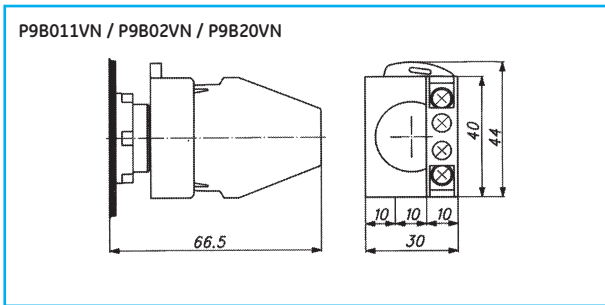
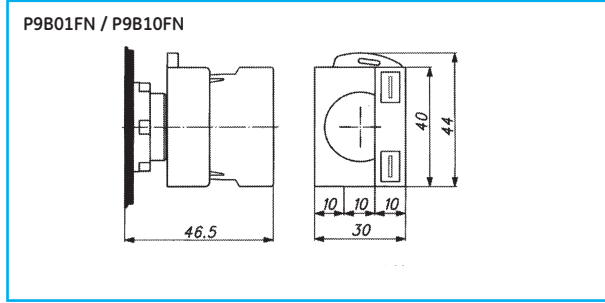
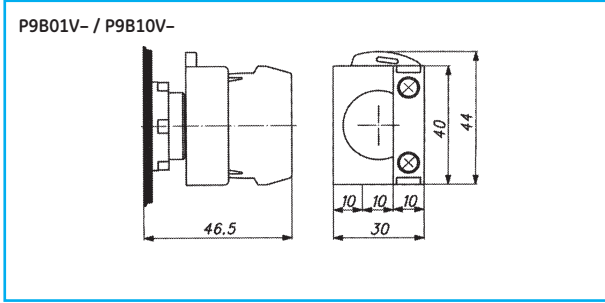

Power supplies

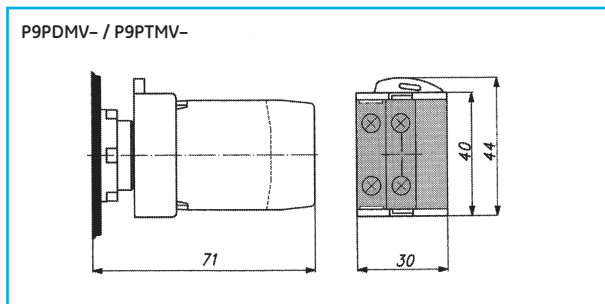
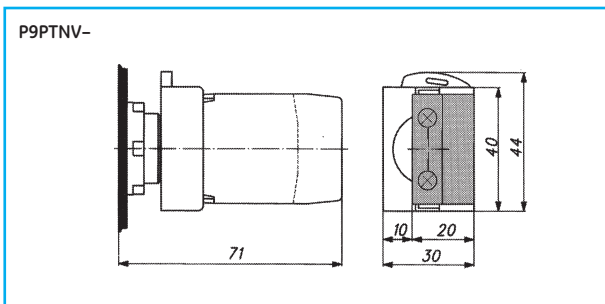
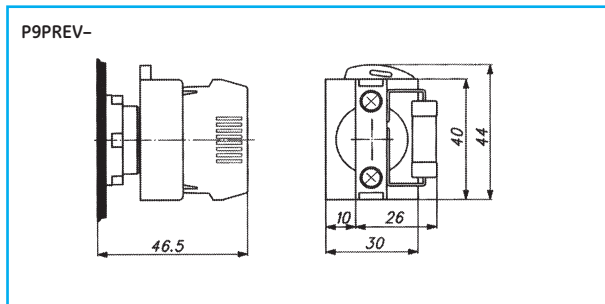
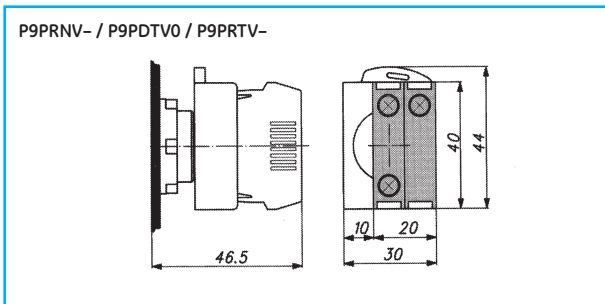
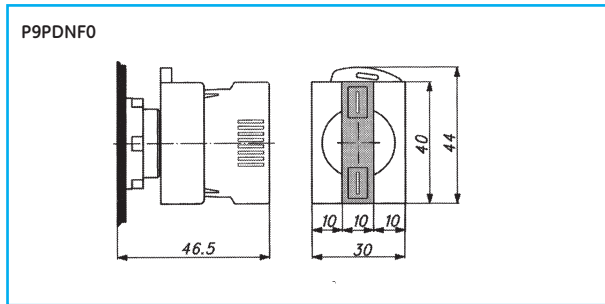
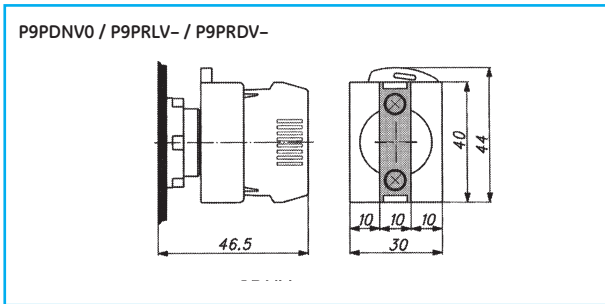

Dimensions in mm (inch = mm x 0.03937) - Weight in kg (lb = kg x 2.2046)



Series P9

Dimensional drawings

Push-on / push-off devices

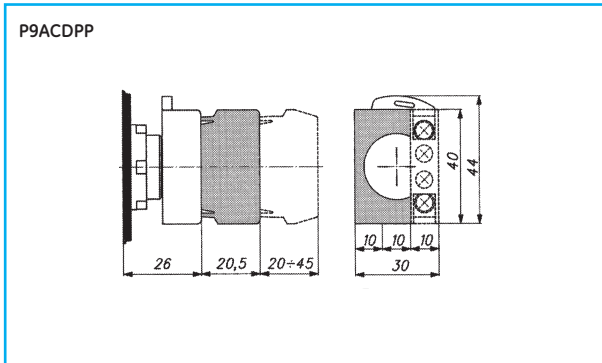

Protection cover

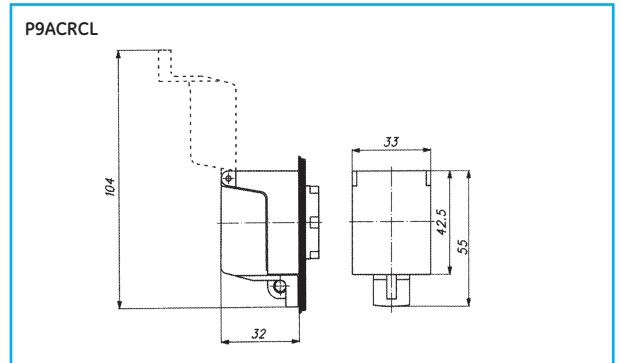

Insert holders and plates

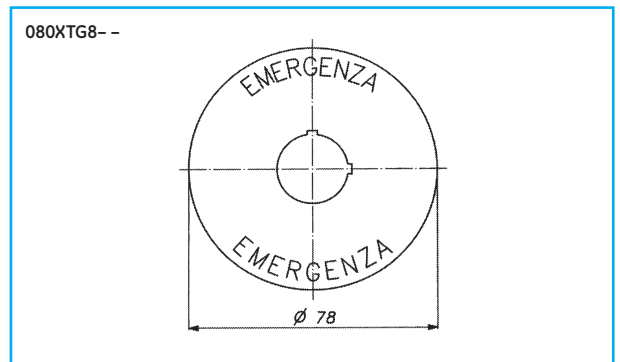
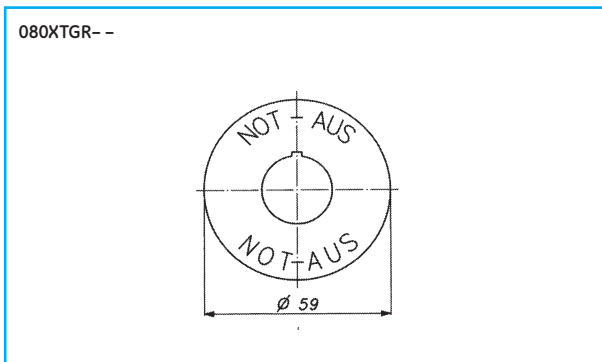
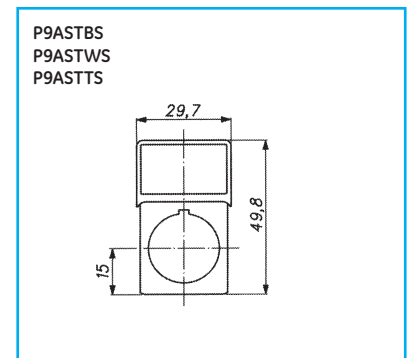
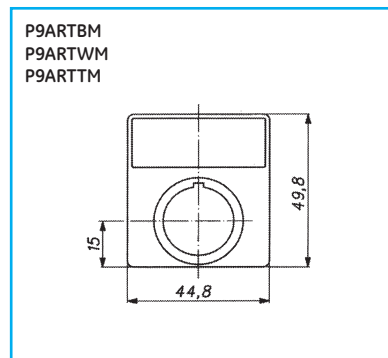
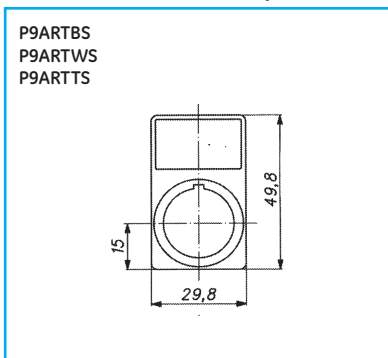

Contact blocks

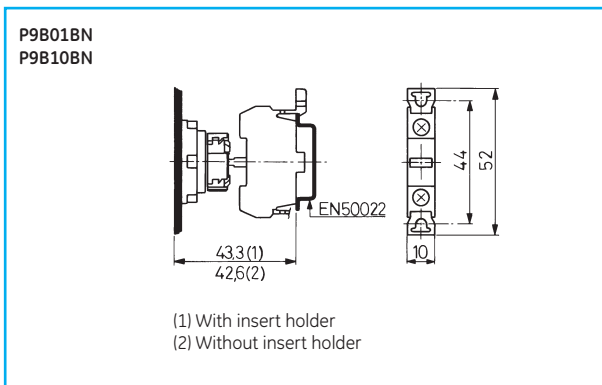

Power supplies

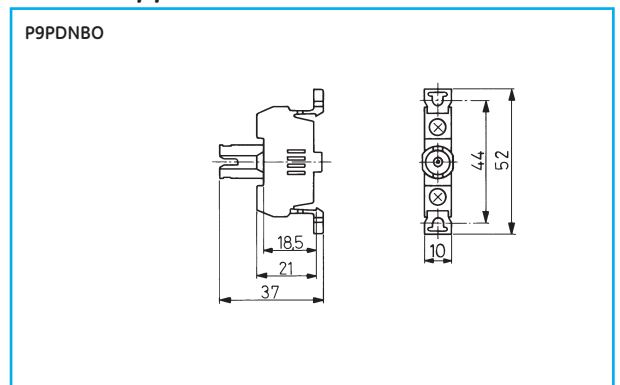

Dimensions in mm (inch = mm x 0.03937) - Weight in kg (lb = kg x 2.2046)



Overall dimensions

Enclosures for push-button stations in thermoplastic

Holes	A	B	C	E1	E2	H
1	72	46	16.5	23 ⁽¹⁾	15.5	57
2	110	78	16.5	23 ⁽¹⁾	21.5	95
3	140	108	16.5	23 ⁽¹⁾	21.5	125
4	175	143	16.5	23 ⁽¹⁾	21.5	160
6	235	200	19.5	29 ⁽²⁾	23	220

(1) Suitable for cable gland, with locknut, PG16 or 1/2" NPT
 (2) Suitable for cable gland, with locknut, PG21 or 3/4" NPT
 (3) Flush push-button: 13
 Pilot light: 14
 Emergency push-button: 50
 Key selector switch: 22
 For customized versions see operator dimensions.

Enclosures for push-button stations in aluminium

Type	Holes Ø 22		Dimensions						Fixing templates	
	vertic.	horizont.	A (mm)	B (mm)	C (mm)	D (mm)	E (mm)	F	H x L x Ø max (mm)	position of the holes
1	1	-	87	87	75	72	21.5	PG 21	74x55x4	1-3
1M	1	-	87	87	100	97	21.5	PG 21	68x55x4	1-3
2	2	-	145	87	75	72	21.5	PG 21	132x55x4	1-3
2M	2	-	145	87	100	97	21.5	PG 21	126x55x4	1-3
3	3	-	195	87	100	97	21.5	PG 21	176x55x4	1-3
4	2	2	145	87	75	72	21.5	PG 21	132x55x4	1-3
4M	2	2	145	87	100	97	21.5	PG 21	126x55x4	1-3
6	3	2	195	87	100	97	21.5	PG 21	176x55x4	1-3
8	2	4	152	152	101.5	98.5	27	PG 29	136x119x6	1-3
12	3	4	205	230	101.5	98.5	27	PG 29	172x214x6	1-2-3-4
18	3	6	257	300	101.5	98.5	35	PG 36	221x282x6	1-2-3-4
24	4	6	257	300	101.5	98.5	35	PG 36	221x282x6	1-2-3-4
35	5	7	350	350	123	106.5	41	PG 36	180x180x10	1-2-3-4

Dimensions in mm (inch = mm x 0.03937) - Weight in kg (lb = kg x 2.2046)



Technical data

Compliance with standards

IEC 947.5.1 - VDE 0660 - NFC 63140
CEI EN 60947.5.1 - UTE - BSI - NEMA
CENELEC EN 50007

Approvals

UL (U.S.A.) - CSA (Canada) - RINA - CE

Climatic protections

The standard versions are suitable for use in the following climates:

Temperate climate	cat. 23/50 (DIN 50014)
Wet climate	cat. 23/83 (DIN 50015)
Hot wet climate	cat. 40/92 (DIN 50015)
Variable wet climate	FW24 (DIN 50016)

Temperature ranges

Operation	-25°C to +70°C
Storage	-40°C to +70°C

Protection degree of the operators

IP65 according to IEC 529 when they are mounted into enclosures with the same or a higher degree of protection. IP66 with appropriate protective caps.

Protection degree of the terminals

IP2x according to IEC 529.
Fully integrated on signalling units, illuminated push-buttons and illuminated selector switches. With accessory on contact blocks for control units.

Rated insulation voltage

690V according to EN 60947.1

Impulse withstand voltage

4 kV according to EN 60947.1

Insulation class

Group C according to VDE 0110

Electric shocks protection

Class I according to IEC 536

Short-circuit protection

With fuses type gI of 10A according to IEC 947.5.1

Connection terminals

Connection terminals
Screw type with retractable clamp.
Clamping capacity of rigid and/or flexible conductors:
- minimum 22 AWG (0.32mm²)
- maximum 12 AWG (3.3mm²)

Performances of the contacts

- Slow acting
- Self-cleaning
- NC forced breaking
- Double break

Electrical performances

Rated thermal current I_{th} = 10A

Performances according IEC 947.5.1

Categorie AC 15 (A600)									
Voltage	Ue (V)	24	48	60	110	220	380	500	600
Current	Ie (A)	10	10	10	6	3	2	1.5	1.2
Categorie DC 13 (P600)									
Voltage	Ue (V)	24	48	60	110	220	300	500	600
Current	Ie (A)	5	2.7	2	1.1	0.55	0.3	0.22	0.2
Categorie DC 13 (Q300) for illuminated push-buttons and illuminated selector switch									
Voltage	Ue (V)	24	48	60	110	220	300		
Current	Ie (A)	2.5	1.1	1	0.55	0.27	0.2		

Performances according to CSA and UL

AC Heavy Duty (A600)	
DC Standard Duty (Q300)	for illuminated push-buttons and illuminated selector switch

Electrical endurance

Alternative current 50/60Hz cat. AC 15

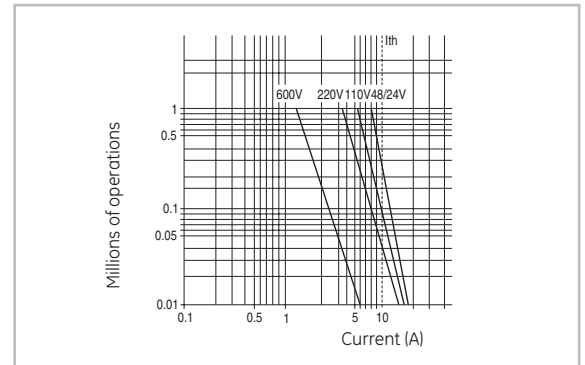

Direct current cat. DC 13

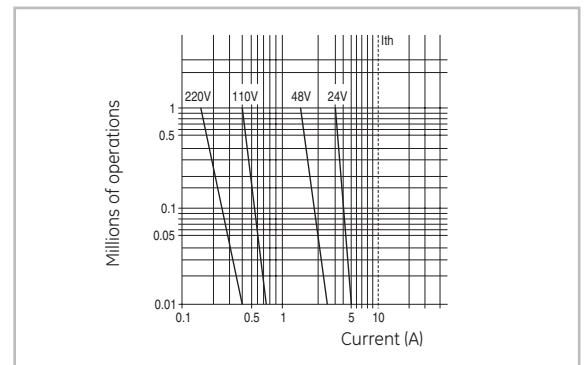

Mechanical endurance

Joysticks	
Key push-buttons	0.5 × 10 ⁶ op.
Locking mushroom push button	
Knob selector switches	
Lever selector switches	
Key selector switches	
Illuminated selector switches	1 × 10 ⁶ op.
Selector push-buttons	
Timed push-buttons	
Illuminated push-buttons	
Momentary std push-buttons	
Momentary mush. push-buttons	3 × 10 ⁶ op.

Number of contact blocks

Momentary standard push-buttons	4 double pole
Momentary mush. push-buttons	(8 single pole)
Key push-buttons	4 double pole
Locking emergency	(4 single pole)
Selector switches	6 double pole
(4 pos. types excl)	(6 single pole)
4 pos. selector switches	2 double pole
Selector push-buttons	6 double pole
	(6 single pole)
Joysticks 2 and 4 positions	4 double pole
	(4 single pole)
Illuminated push-buttons	For different contacts configuration, contact our sales office
Illuminated selector switches	

Fitting of units

The units of Series 077 are designed for fitting onto panels with a thickness between 1 and 7mm., with holes of 30.5mm. diameter, according to rules established by EN 60947.5.1.

A special metal ring supplied with each unit or one of the name plates included among the fittings, enables the unit to be exactly positioned.

All equipment is supplied with a set of spacing rings to adjust variations in the thickness of the panel thus ensuring a uniform front protrusion.

For a correct fitting, it needs to observe the diagram below and tables indications.

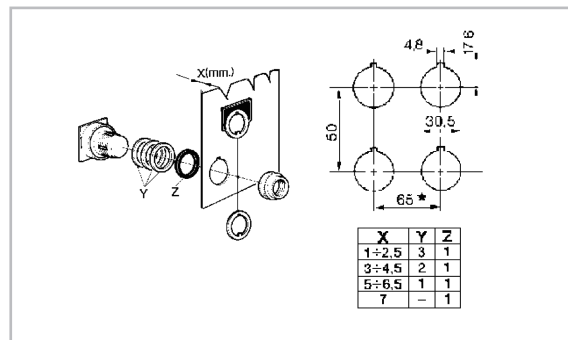

Intro

A

B

C

D

E

F

G







H

I

X



Push-buttons

Standard/Momentary		Description	Contacts	Cat. no.	Ref. no.
			NC+NO	077P11	180019
			NC	077P01	180039
			NO	077P10	180029
Standard/Time delayed ⁽¹⁾		Contacts delayed at the release of the push button. Accuracy ±5% Setting range: 0,1 - 30 sec. 10 - 180 sec.	NC+NO	077P11T30	180120
			NC+NO	077P11T180	180121
To complete by		Description	Ring type	Cat. no.	Ref. no.
	Fixing kits With 4 coloured caps: black, red, green, yellow		with guard	077GGBCN	180020
			without guard	077GSBCN	180010
	With 4 coloured caps: brown, orange, blue, white		with guard	077GGBCS	180050
			without guard	077GSBCS	180040
	With 1 clear and 4 marking etched on both sides		with guard	077GGBCF	180137
			without guard	077GSBCF	180136
					

The catalogue numbers in **bold** are available from stock.

(1) Not approved by RINA and Lloyd's Register

Intro

A

B

C

D

E

F



G

H

I

X

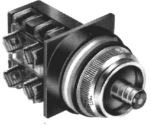
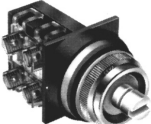
Push-buttons







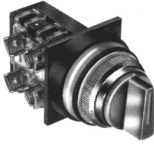

Mushroom head/Momentary	Description	Contacts	Cat. no.	Ref. no.
		NC+NO	077E11	180049
		NC	077E01	180069
		NO	077E10	180059
Mushroom head with latch	Push-twist to release	NC+NO	077RE11	180079
		NC+NO	077RE01	180099
		NC+NO	077RE10	180089
With keylock ⁽¹⁾	Key withdrawable in positions I & II Lockable in position: normal & depressed depressed without pre-setting ⁽²⁾	NC+NO	077PC11C	180100
	Locking  (type G unlock)	NC+NO	077PC11G	180104

(1) Supplied with two standard keys 3095.

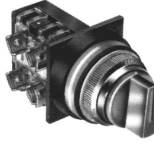







(2) Combined with mushroom head 077ECR makes an mushroom head with latch push-key to release.

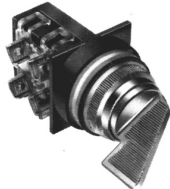

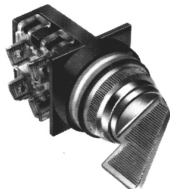
Selector switches with knob

2 positions			Function ⁽¹⁾	Contacts	Cat. no.	Ref. no. see bottom
	Fixed		D	NC+NO	077SDN11	180170
			H	NC+NO	077SHN11	180180
3 positions						
	Fixed		B	NC+NO	077SBN11	180230
			U	2NC+2NO	077SUN22	180440
			Z	2NC+2NO	077S2N22	180480
	With spring return		B	NC+NO	077SBN11SC	180240
			B	NC+NO	077SBN11DC	180250
			B	NC+NO 2NC+2NO	077SBN11RC 077S2N22RC	180260 180510

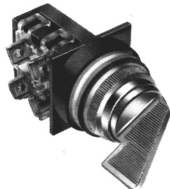







Selector switches with lever

2 positions			Function ⁽¹⁾	Contacts	Cat. no. Metal	Ref. no.
	Fixed		D	NC+NO	077SLD11	180601
3 positions						
	Fixed		B	NC+NO	077SLB11	180607
			Z	2NC+2NO	077SLZ22	180623
	With spring return		Z	2NC+2NO	077SLZ22DC	180625
			Z	2NC+2NO	077SLZ22RC	180626
4 positions						
	Fixed		X	2NC+2NO	077SLX22	180606

The catalogue numbers in **bold** are available from stock.

(1) Electrical diagrams, see F.57

Selector switches with key⁽¹⁾

2 positions			Function ⁽²⁾	Contacts	Key removal	Cat. no.	Ref. no.
	Fixed		D	NC+NO	I	077SCD1101	180630
				NC+NO	II	077SCD1105	180631
				NC+NO	I-II	077SCD1109	180632
	With spring return		I	NC+NO	0	077SCI11DC03	180640
				H	NC+NO	0	077SCH11SC03
3 positions							
	Fixed		B	NC+NO	I-0-II	077SCB1120	180843
	With spring return		B	NC+NO	I-0	077SCB11DC07	180852
			Z	NC+NO	I	077SCZ22DC01	180906
				B	NC+NO	0	077SCB11RC03







The catalogue numbers in **bold** are available from stock.

(1) Supplied with two standard keys 3095.

(2) Electrical diagrams, see F.57



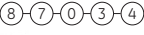

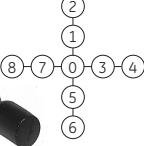
Joysticks

2 positions + central zero position		Function ⁽¹⁾	Contacts	Cat. no.	Ref. no.	Cat. no.	Ref. no.
				Without interlock	With interlock		
 	Fixed position	N	2NC+2NO	077MTS2422	180910	077MTS2422B	181000
		R	2NC+2NO	077MTS2422R	180912	077MTS2422RB	181002
	Transient position	N	2NC+2NO	077MT24S22	180911	077MT24S22B	181001
		R	2NC+2NO	077MT24S22R	180913	077MT24S22RB	181003
<hr/>							
4 positions + central zero position							
 	Fixed positions	N	2NC+2NO	077MTS123422	180914	077MTS123422B	181004
	Transient positions		2NC+2NO	077MT1234S22	180915	077MT1234S22B	181005
<hr/>							
2+2 positions + central zero position							
 	Fixed positions	X	4NC+4NO	077M2S2SX44	180918	077M2S2SX44B	181008
	Transient positions 4, 8 transient -3, 7 fixed		4NC+4NO	077M2T2TX44	180919	077M2T2TX44B	181009
				4NC+4NO	077M2S2TX44	180921	
	Transient positions	Y	4NC+4NO	077M2T2TY44	180923		
<hr/>							
4+4 positions + central zero position							
 	Transient positions 2, 4, 6, 8 transient -1, 3, 5, 7 fixed	X	8NC+8NO	077M4T4TX88	180927		
			8NC+8NO	077M4S4TX88	180929	077M4S4TX88B	181019
	Transient positions	Y	8NC+8NO	077M4T4TY88	180931	077M4T4TY88B	181021

The catalogue numbers in **bold** are available from stock.

(1) Electrical diagrams, see F.57

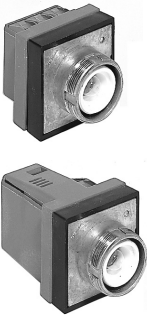
Illuminated push-buttons

Momentary		Description	Contacts	Cat. no.	Ref. no.
		Full voltage ~ / \equiv BA9s max 380V - 2 W not included	NC+NO	077PLM11D0	181040
			NO+NO	077PLM20D0	181041
			NO	077PLM10D0	181043
		With transformer 50/60Hz BA9s6V-1.5W included	NC+NO	077PLM11T♦	
To complete by					
		Lenses			
		Standard Mushroom head Ø 35mm (to use with the fixing ring 077GG03)		077GPL ● 077GELR	see bottom 180971
		Locking rings			
		Without guard		077GG03	180980
		With metal guard		077GGM	180981
		With transparent guard		077GGT	180982





The catalogue numbers in **bold** are available from stock.

Suffix	110-120V	220-250V
♦	J	N

Colours	red	green	yellow	orange	bleu	white	clear
Standard lenses	R	V	G	A	BL	B	I



Illuminated selector switches

2 positions		Function ⁽¹⁾	Contacts	Cat. no.	Ref. no.
	Fixed	D	NC+NO	077ISD11D0	181060
3 positions					
	Fixed	B	NC+NO	077ISB11D0	181170
			NC+NO	077ISB11T♦	
	With spring return	B	NC+NO	077ISB11D0RC	181174
		Z	NC+NO	077ISZ11D0RC	181176
To complete by					
	Lenses				
	Knob			077MIS●	see bottom

The catalogue numbers in **bold** are available from stock.

(1) Electrical diagrams, see F.57

Suffix	110-120V	220-250V	
♦	J	N	
Colours	red	green	yellow
●	R	V	G

Intro

A

B

C

D

E

F

G

H

I

X

Pilot lights

	Description	Cat. no.	Ref. no.
	Full voltage ~ / \equiv BA9s max. 380V-2W not included	077LDNV0	181300
	With resistor ~ / \equiv 110-120V, BA9s60V-1.2W included 220-240V, BA9s130V-2W included	077LRNVJ 077LRNVN	181301 181302
	With transformer 50/60Hz BA9s6v-1.5w included	077LTNV♦	
	Multifunction ⁽¹⁾ full voltage 24V ~ / \equiv BA9s24V-2W included	077LDMVD	181305
	Multifunction ⁽¹⁾ with transformer 50/60Hz BA9s6V-0.6W included	077LTMV♦	
To complete by			
	Lenses		
	Plastic version	077GL●	see bottom
	Full voltage ; / \equiv For bulb E14 base max 660V(1)-6W not included	077DLE14	181260
To complete by			
	Lenses		
	For pilot lights 077DLE14 - plastic version	099GW1●	see bottom







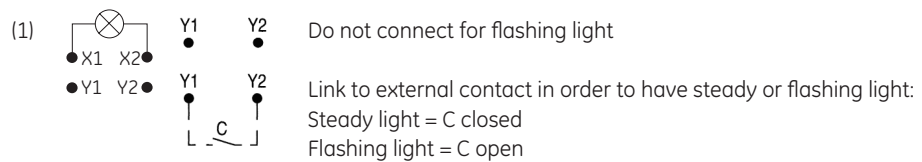





The catalogue numbers in **bold** are available from stock.

Suffix	110-120V	220-250V
♦	J	N

Colours	red	green	yellow	orange	blue	white	grey
●	R	V	G	A	BL	B	H







Accessories

		Description	Cat. no.	Ref. no.
	Push-on/ push-off device	For momentary standard push-buttons Converts momentary push-button to push-on/push-off. This device can only be used with 077-01 (NC) and/or 077-10A (NO early make) contact blocks.	077DPP	181550
	Push-pull to release device	For momentary mushroom push-buttons Converts momentary mushroom push-button to push to latch/pull to release.	077DAE	181554
	Handles	Knob for selector switches	077M●	see bottom
	Protection	Guard-ring for mushroom head push-button dia 35mm.	077GE35	181620
	Plug	For unused mounting hole.	077TPF	181601
	Potentiometer operator	Suitable for potentiometers with shaft 50mm long and 6mm diameter. Potentiometer not included.	077OPZ	181570
	Rubber protective caps	For standard push-buttons Coloured Clear	077CP● 077CPT	see bottom 181588
		For illuminated standard push-buttons Clear	077CPLT	181600
		For knob selector switches Black colour with clear knob	077CST	181603
	Spare keys	Standard version	Code 3095 077C3095	173095
	Bulbs BA9s	Filament type	Vn	Wn
			6	0.6
			6	1.5
			12	2
			24	2
			30	2.1
			48	2
			60	1.2
			130	2
		Neon type	110	0.11
			220	0.33
			BA9S606	187850
			BA9S615	187851
			BA9S122	187852
			BA9S242	187853
			BA9S30	187854
			BA9S48	187855
			BA9S6012	187856
			BA9S130	187857
			BA9SN110	187860
			BA9SN220	187861









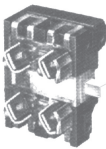
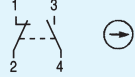

The catalogue numbers in **bold** are available from stock.

Colours ●	black	red	green	yellow	blue	white
Knobs	N	R	V	G	BL	-
Protective caps	N	R	V	G	-	-
Mono LED	-	R	V	G	BL	B

Nameplates

	Description	Cat. no.	Ref. no.	
	Without text (black background)	077TNA	181650	
	With text in English (black background)	 STOP	077TNA40	181840
	Without text (black background)	077TNA2	181660	
	With text (black background)	ON - OFF	077TNA230	181930
	Without text (black background)	077TNA3	181670	
	With text (black background)	MANUAL CYCLE-O-AUTOMATIC	077TNA301	181951
		OPEN - OFF - CLOSE	077TNA312	181962
		UP - OFF - DOWN	077TNA313	181963
	Without text (yellow background)	077TGR	181720	
	With text (yellow background)	EMERGENCY STOP	077TGRQ2	181722

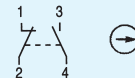
Contact blocks

2 positions		Contacts	Cat. no.	Ref. no.	
	For all the applications Illuminated push-buttons and illuminated selector switches excluded				
	Standard		NC+NO	077-11	180001
			NC	077-01	180003
			NO	077-10	180002
			NC late opening	077-01R	180008
			NO early closing	077-10A	180007
	Accessories for contact blocks 077-... IP2X protection	for use with NO	077PTB10	181608	
		for use with NC	077PTB01	181609	
		for use with NO+NC	077PTB11	181615	
	For 2 + 2 and 4 + 4 positions joysticks Snap action		099SPDTDB	180009	
		For illuminated push-buttons and illuminated selector switches		NC+NO	P9B11VN
			NC	P9B01VN	187001
			NO	P9B10VN	187002

The catalogue numbers in **bold** are available from stock.



Enclosures for push-button stations in aluminium alloy (Grey RAL 7012)

Control and signalling units Ø 30mm

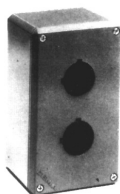

Cover with holes
with conduit entry

No. of holes	Type	Cat. no.	Ref. no.
1	1	077SP1	180521
1	1M	077SP1M	180522
2	2	077SP2	180523
2	2M	077SP2M	180524
3	3	077SP3	180525
4	4V	077SP4V	180526
4	4	077SP4	180527
6	6	077SP6	180528
9	9	077SP9	180529
12	12	077SP12	180530
16	16	077SP16	180531
20	20	077SP20	180532
25	25	077SP25	180533
30	30	077SP30	180534
36	36	077SP36	180535
		077-01R	180008

Cover with holes
without conduit entry

1	1	077SP1SFE	180536
1	1M	077SP1MSFE	180537
2	2	077SP2SFE	180538
2	2M	077SP2MSFE	180539
3	3	077SP3SFE	180540
4	4V	077SP4VSFE	180541
4	4	077SP4SFE	180542
6	6	077SP6SFE	180543
9	9	077SP9SFE	180544
12	12	077SP12SFE	180545
16	16	077SP16SFE	180546
20	20	077SP20SFE	180547
25	25	077SP25SFE	180548
30	30	077SP30SFE	180549
36	36	077SP36SFE	180550

Cover without holes
with conduit entry



1	1	080SP1SFC	170835
1M	1M	080SP1MSFC	170838
2	2	080SP2SFC	170841
2M	2M	080SP2MSFC	170844
3	3	080SP3SFC	170847
4V	4V	077SP4VSFC	180551
4	4	080SP8SFC	170853
6	6	080SP12SFC	170856
9	9	080SP12SFC	170856
12	12	080SP18SFC	170859
16	16	080SP18SFC	170859
20	20	080SP35SFC	170863
25	25	080SP35SFC	170863
30	30	077SP36SFC	180552
36	36	077SP36SFC	180552

Cover without holes
without conduit entry

1	1	080SP1SF	170837
1M	1M	080SP1MSF	170840
2	2	080SP2SF	170843
2M	2M	080SP2MSF	170846
3	3	080SP3SF	170849
4V	4V	077SP4VSF	180553
4	4	080SP8SF	170855
6	6	080SP12SF	170858
9	9	080SP12SF	170858
12	12	080SP18SF	170861
16	16	080SP18SF	170861
20	20	080SP35SF	170865
25	25	080SP35SF	170865
30	30	077SP36SF	180554
36	36	077SP36SF	180554

Accessories
Kit of two hinges for types
from 12 to 36 holes.

080KCSP 170883

The catalogue numbers in **bold** are available from stock.



Intro
A
B
C
D
E
F
G
H
I
X

Diagrams

Selector switches

	Function	Contacts	Diagram
	D 077 11...		
	I 077 11...		
	H 077 11...		
	B 077 11...		
	Z 077 11... 077 11...		

Illuminated selector switches

Full voltage type	Function	Contacts	Diagram
	D 077 10... 077 01...		
	B 077 10... 077 01...		
	Z 077 10... 077 01...		

Joysticks

Positions	Function	Contacts	Diagram
	N 077 11... 077 11...		
	R 077 11... 077 11...		
	N 077 11... 077 11...		

Joysticks

Positions	Function	Contacts	Diagram
	X 077 11... 077 11... 077 11... 077 11...		
	Y 077 11... 077 11... 077 11... 077 11...		
	X 077 11... 077 11... 077 11... 077 11... 077 11... 077 11... 077 11... 077 11...		
	Y 077 11... 077 11... 077 11... 077 11... 077 11... 077 11... 077 11... 077 11...		

■ = closed contact



Series 077

Dimensional drawings

Push-buttons

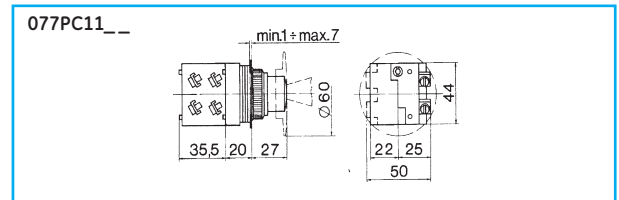
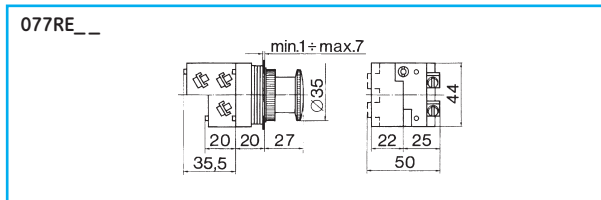
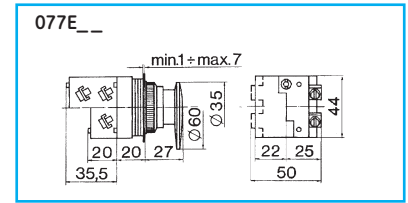
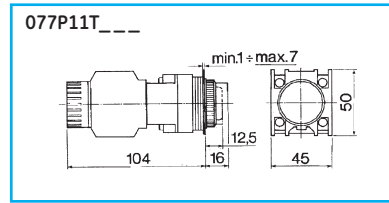
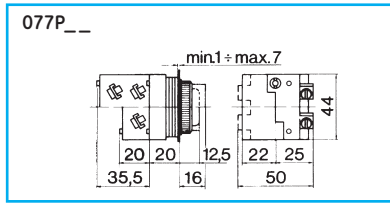

Selector switches

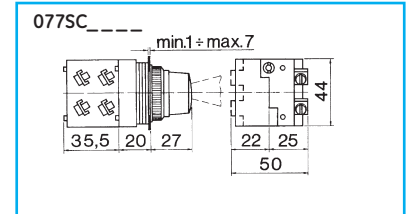
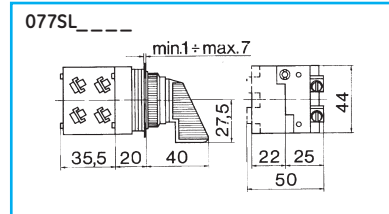
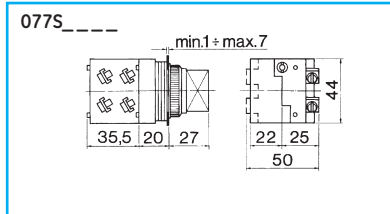

Joysticks

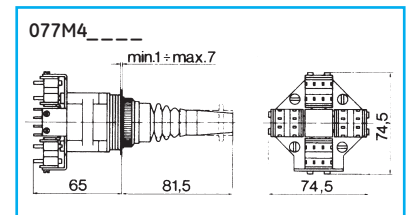
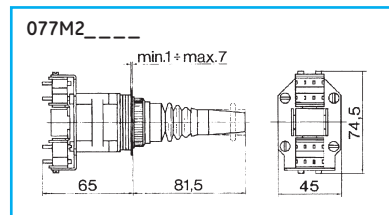
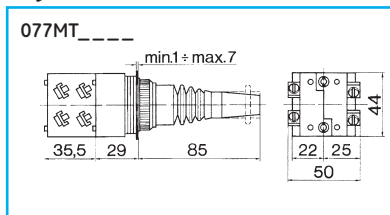

Illuminated push-buttons

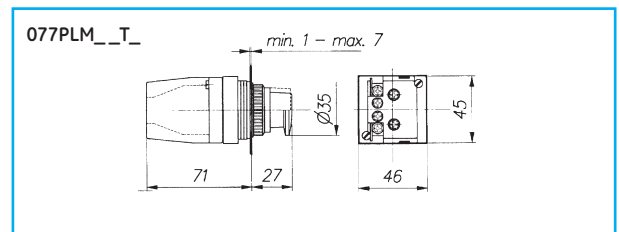
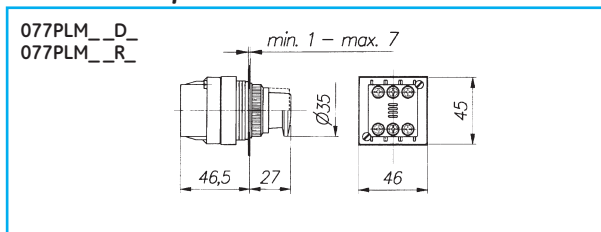

Illuminated selector switches

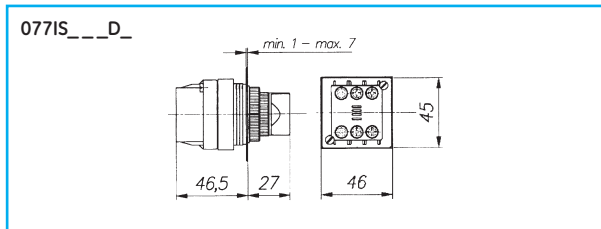

Pilot lights

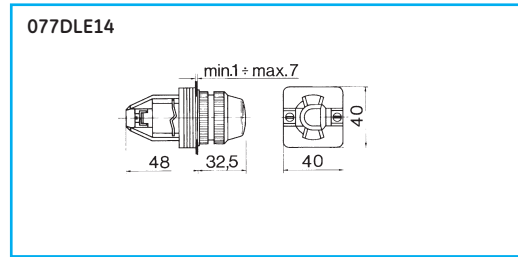
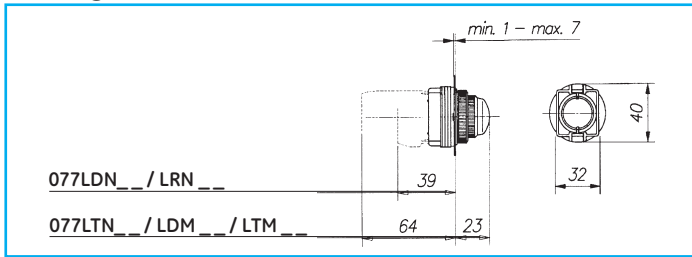

Kits

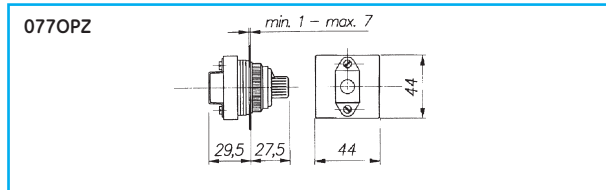
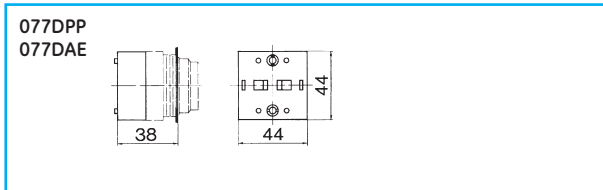

Nameplates

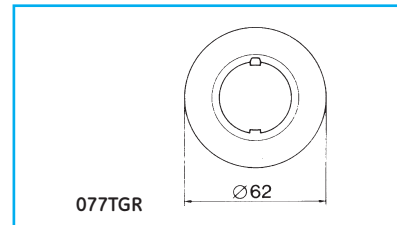
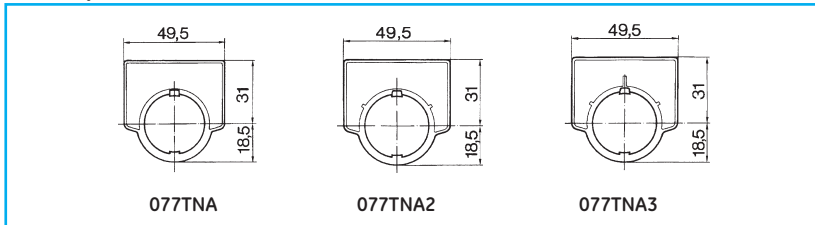

Contact blocks

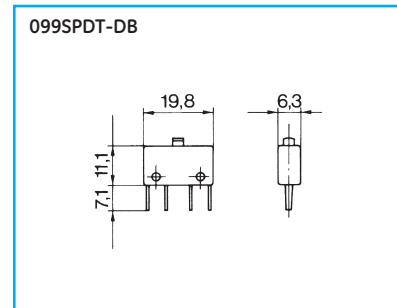
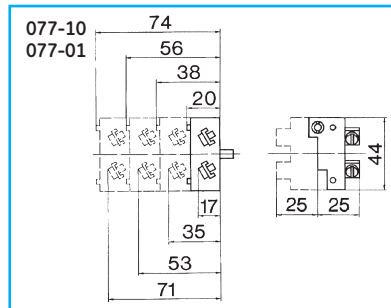
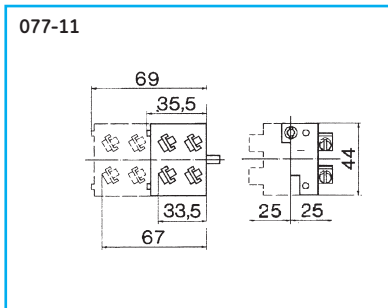

Dimensional drawings

Aluminium enclosures

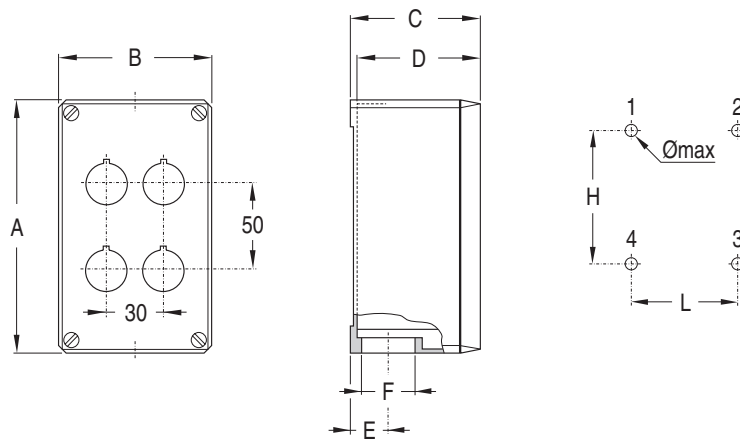

Type	Number of holes Ø 30		Dimensions						Fixing templates	
	Vertic.	Horizont.	A (mm)	B (mm)	C (mm)	D (mm)	E (mm)	F	HxLxØ max (mm)	position of the holes
1	-	-	87	87	75	72	21.5	PG 21	74x55x4	1 - 3
1M	-	-	87	87	100	97	21.5	PG 21	68x55x4	1 - 3
2	2	-	145	87	75	72	21.5	PG 21	132x55x4	1 - 3
2M	2	-	145	87	100	97	21.5	PG 21	126x55x4	1 - 3
3	3	-	195	87	100	97	21.5	PG 21	176x55x4	1 - 3
4V	4	-	257	92	86.5	83.5	23	PG 21	224x76x6	1 - 3
4	2	2	152	152	101.5	98.5	27	PG 29	136x119x6	1 - 3
6	2	3	205	230	101.5	98.5	27	PG 29	172x214x6	1-2-3-4
9	3	3	205	230	101.5	98.5	27	PG 29	172x214x6	1-2-3-4
12	3	4	257	300	101.5	98.5	35	PG 36	221x282x6	1-2-3-4
16	4	4	257	300	101.5	98.5	35	PG 36	221x282x6	1-2-3-4
20	5	4	350	350	123.5	106.5	41	PG 36	180x180x10	1-2-3-4
25	5	5	350	350	123.5	106.5	41	PG 36	180x180x10	1-2-3-4
30	6	5	410	410	144.5	127.5	53	PG 48	180x180x10	1-2-3-4
36	6	6	410	410	144.5	127.5	53	PG 48	180x180x10	1-2-3-4

Dimensions in mm (inch = mm x 0.03937) - Weight in kg (lb = kg x 2.2046)



Signalling devices

General

Series 105 signalling units are used to indicate the electric equipment power supply conditions. For this purpose the devices shall be wired after the main disconnecting switch and clearly in view when the cabinet's doors are opened. Series 105 DTL devices can be used on three-phase lines with or without the neutral wire or single-phase power lines, indicating the hazardous condition due to the applied voltage. Three luminous red lamps are used. The flashing devices are normally used in combination with limit switches contacts NC type 114FCT03 that provides insertion when the cabinet door are open only.

Climatic protection

The standard versions are suitable for use in the following climates:

- Temperate climate cat. 23/50 (DIN 50014)
- Wet climate cat. 23/83 (DIN 50015)
- Hot wet climate cat. 40/92 (DIN 50015)
- Variable wet climate cat. FW 24 (DIN 50016)

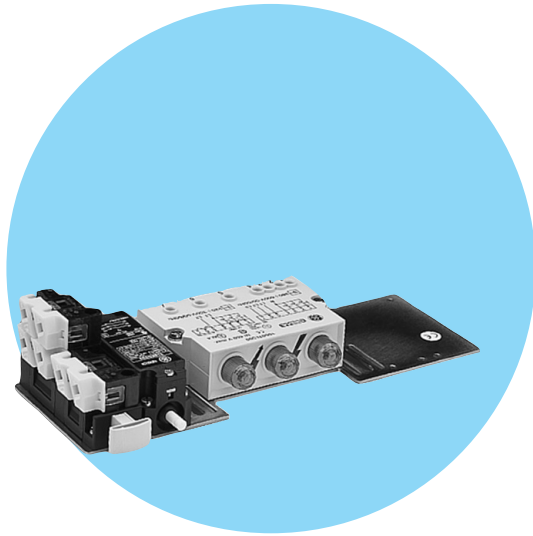

Standards

CEI, IEC, VDE, BSI and UTE

Approvals

CE, UL, CSA

Suggested connections

Indicates the presence of 3, 2 or 1 phase only by means of the relative lamp.

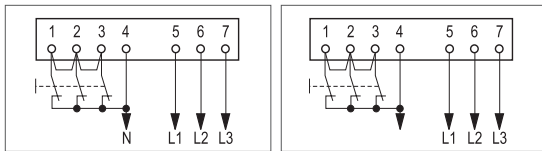

3-phase line with insulated neutral 3-phase line with grounded neutral

Indicates the presence of 3 or 2 phases by means of the relative lamp. One phase only is not indicated (all lamps OFF)

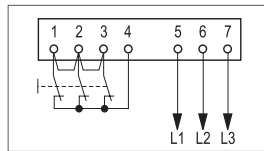

3-phase line without neutral

Indicates both phases with 3 lamps ON at same time. One phase only is not indicated (all lamps OFF)

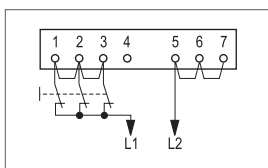

Single-phase line (general diagram)

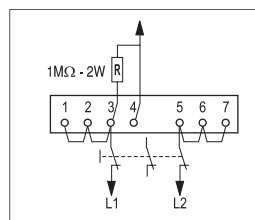

Single phase-line (alternative diagram)

1. Phase to phase connection on a 3 phase line with grounded neutral. Indicates the presence of 2-phases or 1 only with the 3 lamps ON at the same time.
2. Phase to neutral connection on a 3 phase line with grounded neutral or phase to phase by a matching transformer with one phase grounded. Indicates the presence of the ungrounded phase with the 3 lamps ON at the same time. No indication occur if the ungrounded phase is missing (all lamps OFF).

Specifications

Temperature ranges	Operation	from -25°C up to +70°C
	Storage	from -40°C up to +70°C
Degree of protection (according to IEC 529)		IP 20
Electrical		
Rated insulation voltage according to EN 60947.1		690V
Impulse withstand voltage according to EN 60947.1		4kV
Electrical input		2mA max.
Connections	Terminal strip with numbered terminals, accessible from outside	
Clamping capacity	protected against accidental contacts according to DIN 57106 and IP 20 according to IEC 529	
	Maximum one flexible conductor 12 AWG (3.3mm ²)	

Order codes ● page F.62
Dimensional drawings ● page F.64



Flashing devices



Supply voltage		Cat. no.	Ref. no.	Pack
Three-phase (50-60Hz)	Single-phase (50/60Hz)			
220V	110-127V	105DTL220	132230	1
380-600V 690V	220-350V	105DTL500 105DTL690	132231 132232	1 1

3 pole limit switch for device control



Protection degree	Cables entry	Operation force	Contacts	Cat. no.	Ref. no.	Pack
IP40	PG11	8.5 N min.	3NC	114FCT03	130320	25
IP65	PG11	8.5 N min.	3NC	114FCT03T	130321	25

Paralell bridge for 3 poles limit switches



Cat. no.	Ref. no.	Pack
105 PT	132234	50x5

Paralell bridge for 3 poles limit switches



The unit includes the following components:

- one flashing device 105DTL220 or 105DTL500.
- one 3-pole limit switch 114FCT03 for connection of the flashing device
- one electrical interlock device and panel light 105GIL or 105GIL10.
- one mounting plate 105PM on which are fitted on the above devices.

If two doors have to be protected (as double enclosure closing on the middle) the mounting plate shall be fitted also one limit switch 114FCT03 and one device 105GIL or 105GIL10.

Approvals:

UL (USA) - CSA (Canada)

Supply voltage			Cat. no.	Ref. no.	Pack
Three-phase (50-60Hz)	Single-phase (50/60Hz)	Tripping coil			
220V	110-127V	Shunt trip	105GP1P220	132250	1
220V	110-127V	Undervoltage trip	105GP1P220M	132251	1
380-600V	220-350V	Shunt trip	105GP1P500	132252	1
380-600V	220-350V	Undervoltage trip	105GP1P500M	132253	1

Electrical interlock device and cubicle lighting⁽¹⁾



The switch can be directly driven by the enclosure door.
If several doors are employed, one switch per door shall be used.
When properly connected, the following functions are provided:

- Position 1 (pushed) door closed: light OFF, tripping coil of main switch unpowered (normal equipment operation)
- Position 2. (free) door opening: light ON, tripping coil of main switch powered (equipment shall cut-out automatically).
- Position 3 (pulled) door open: light ON, tripping coil of main switch unpowered (adjustment on the equipment of dry checks). When door is closed again, the switch revert automatically from position 2 or 3 to position 1.

Terminals have IP2X protection degree according to IEC/EN 60529

Approvals:

UL (USA) - CSA (Canada)

Tripping coil		Cat. no.	Ref. no.	Pack																
Shunt trip		105 GIL	132240	1																
	<table border="1"> <thead> <tr> <th></th> <th>1</th> <th>2</th> <th>3</th> </tr> </thead> <tbody> <tr> <td>E</td> <td></td> <td></td> <td></td> </tr> <tr> <td>F</td> <td></td> <td></td> <td></td> </tr> <tr> <td>G</td> <td></td> <td></td> <td></td> </tr> </tbody> </table>		1	2	3	E				F				G						
	1	2	3																	
E																				
F																				
G																				
Undervoltage trip		105 GIL 10	132241	1																
	<table border="1"> <thead> <tr> <th></th> <th>1</th> <th>2</th> <th>3</th> </tr> </thead> <tbody> <tr> <td>E</td> <td></td> <td></td> <td></td> </tr> <tr> <td>F</td> <td></td> <td></td> <td></td> </tr> <tr> <td>G</td> <td></td> <td></td> <td></td> </tr> </tbody> </table>		1	2	3	E				F				G						
	1	2	3																	
E																				
F																				
G																				

Electrical interlock device⁽¹⁾



The switch is directly driven by the enclosure door.
If several doors are employed, one switch per door is needed.
When properly connected, the same functions of devices above shall be provided but without enclosure control light.
Terminals have IP2X protection degree according to IEC 529

Tripping coil		Cat. no.	Ref. no.	Pack								
Shunt trip		105 CI	132242	1								
	<table border="1"> <thead> <tr> <th></th> <th>1</th> <th>2</th> <th>3</th> </tr> </thead> <tbody> <tr> <td>G</td> <td></td> <td></td> <td></td> </tr> </tbody> </table>		1	2	3	G						
	1	2	3									
G												
Undervoltage trip		105 CI 10	132243	1								
	<table border="1"> <thead> <tr> <th></th> <th>1</th> <th>2</th> <th>3</th> </tr> </thead> <tbody> <tr> <td>G</td> <td></td> <td></td> <td></td> </tr> </tbody> </table>		1	2	3	G						
	1	2	3									
G												

Mounting plate



	Cat. no.	Ref. no.	Pack
	105 PM	132244	1

(1) For electrical performance and features of contact blocks please see F.44



Dimensional drawings

Series 105 - Flashing devices

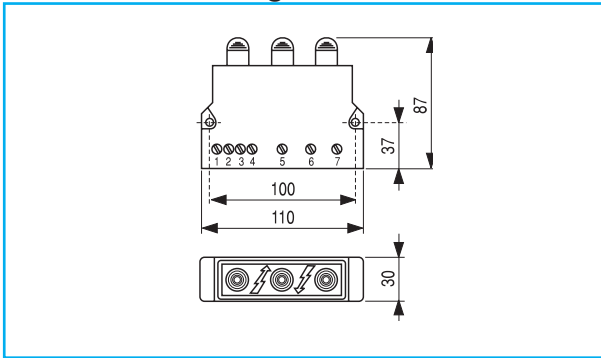

Series 105 - Single door protection unit

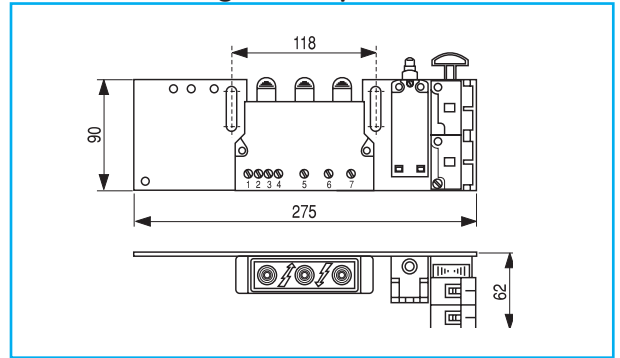

Series 105 - Electrical interlock and cubicle lighting

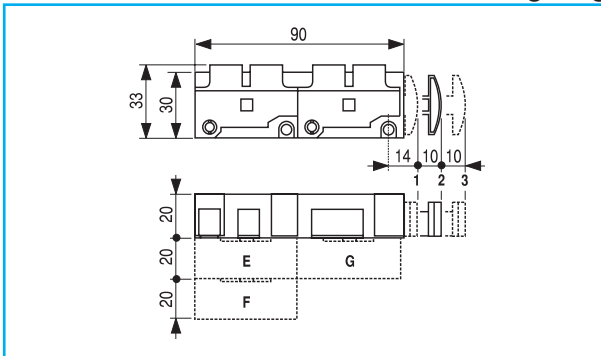

Series 105 - 3 pole limit switch for device control

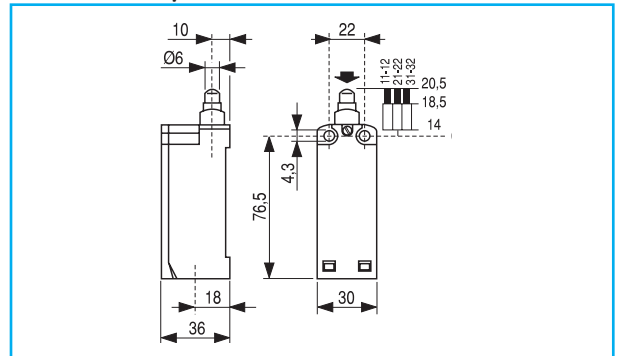

Series 105 - Electrical interlock device

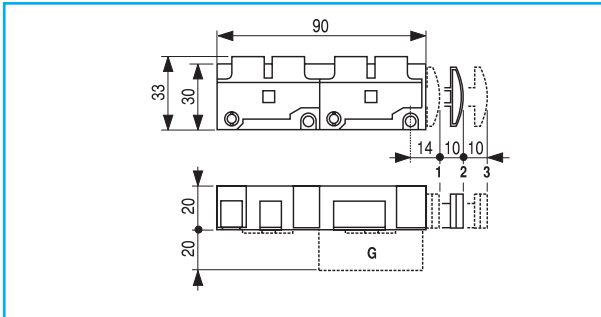

Series 105 - Mounting plate

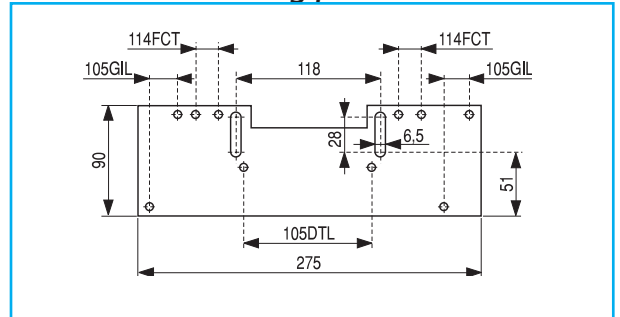

Dimensions in mm (inch = mm x 0.03937) - Weight in kg (lb = kg x 2.2046)



					Intro
G.2 AF Drives	POWER DEVICES	Contactors and overload relays			A
G.2 Introduction					
G.8 AF-70 LP - Micro Drives		Auxiliary relays and contactors			B
G.18 AF-700 FP - Fan and Pump Drives					
		Motor protection devices			C
G.28 AF-60 LP - Micro Drives					
G.34 AF-650 GP - General Purpose Drives			Applications		D
G.52 AF-600 FP - Fan and Pump Drives	AUXILIARY DEVICES		Main switches		E
G.72 AF Drives - Options and Accessories		Control and signalling units			F
	POWER ELECTRONICS		Speed drive units		G
			Soft starters		H
	ENCLOSURES		Product overview		I
			Alphabetical index		X



Highlight of benefits

One family

- For both general purpose and fan/pump applications
- Just one drive series to run an entire production line
- Broad range: 180W to 1.4 MW, 230 V – 690 V

Designed for lifetime

- Built-in communication for easier integration
- Built-in DC chokes increase the lifetime of the capacitors
- Conformal coating available

Low operating costs

- Low energy consumption – up to 98% efficiency
- Less energy needed for cooling
- Automatic Energy Optimizer (AEO) potentially saves up to 5% energy compared to standard drives
- Low cost of ownership – no periodic maintenance/ replacement cost

Constant torque applications Heavy Duty

Constant torque applications include those where the load does not change significantly with the speed as **conveyors, lifting gear and mixers**.

A motor block on a conveyor will always weight the same, regardless of whether the conveyor is running at low or high speed.

The torque required to move this motor block is always the same. Although friction and acceleration torques will vary depending on the operating state, the torque requirement for the load remains constant.

The power required by a system of this type is proportional to the torque required and to the speed of the motor.

Savings can be achieved directly if the speed can be reduced at constant load. Adapting the speed of the belt to the quantity of goods to be transported not only enables those goods to be processed without interruption but also leads to a **reduction on the energy required**.



Variable torque applications Light Duty

Often involve **pumps and fans**. However, a distinction has to be made in the case of pumps. Although the most popular types of centrifugal pump have a quadratic torque characteristic but **eccentric, vacuum or positive displacement pumps have a constant torque characteristic**. Pumps and fans have a significant share of all power consumed by industrial applications, with consumption levels approximately at 40%. Speed control is a simple yet very effective way of saving energy where fans and pumps with variable load torques are concerned.

Reducing the speed generates a cubic reduction in energy requirements. This significant potential for savings makes all applications with variable torque ideal candidates for the implementation of energy saving. Operators need to take into account that changes in speed alter the operating point and affect the efficiency. If the difference between the maximum power required and average part-load operation is too great, systems should be cascaded. It is often the case that investments pay for themselves relatively quickly when existing systems are converted.

Built-in EMC (RFI) filter

- Drive is ready to use and faults due to incorrect installation or wrong filter selection are avoided
- Immunity from electrical interference and minimal emission
- Saves panel space and installation costs
- Facilitates meeting CE EMC directives

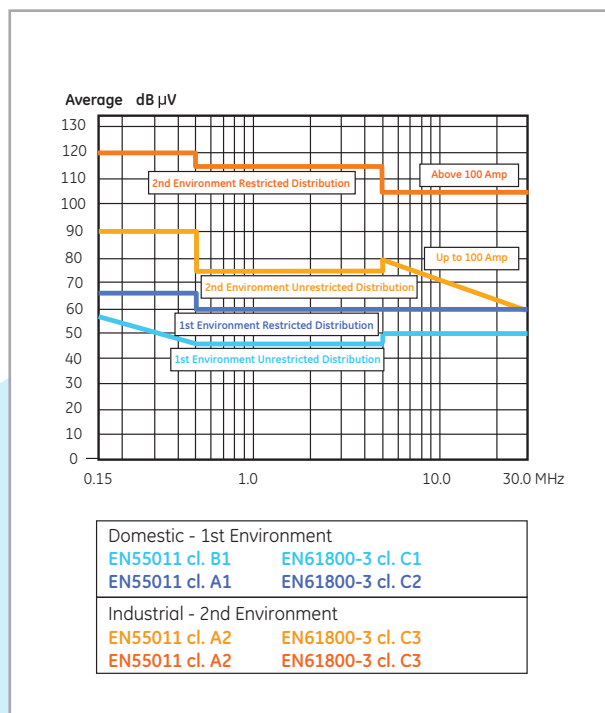

Built-in DC link reactor (AF-6x0)

- Low harmonic emission: THDi < 48%
- No voltage drop => full output voltage
- Reduces installation cost
- Fulfils EN 61000-3-2/3-12
- True power factor 0.9

Reliable operation in harsh environment

- Protection against environmental pollution, aggressive gasses, moisture and dust
- Reduces the probability of failure resulting in less down-time
- Increases the lifetime of the drive
- High protection Class 3C2 **as standard** and increased protection in harsh environments with Class 3C3 **as optional**
- Optional conformal coating is tested to ANSI/ISA S71.04-1985 Class G3 (airborne gasses - harsh) and Class GX (airborne gasses - severe)

High immunity

- Immunity to fluctuating supply voltage (+/- 10%)
- Efficient overvoltage protection
- Fully short-circuit- and earth-leakage proof
- 100kA prospective short-circuit current capability



AF Drives

Special pump functions functions (AF-600 & AF-700)

No flow detection

- No flow detection is based on speed and power
- Two sets of data must be programmed into the drive
- Manual or auto set up
- Used to enable sleep mode in closed loop systems for energy savings

End-of-curve protection

- If there is a water leak in the pipe, it will not produce pressure
- The pump is delivering a large volume of water but cannot maintain the static head
- Drive will go to full flow to try producing pressure (set point)
- The drive running at high speed with a feedback signal less than 97.5% of the set point pressure causes End of Curve action

Dry pump protection

- Special no-flow condition, where pressure can not be produced, if there is no water
- Drive will go to full speed to try producing full pressure
- Low power consumption at high speed causes Dry Pump action



Applications



AF Drives

Intro

A

B

C

D

G

H

I

X



PC software tool

- On and offline commission
- Help description for each drive parameter
- Oscilloscope function
- Logging of alarms and warnings for improved system performance and documentation
- Interacts with process management
- Communicates through USB, RS485 or Network

Plug-in option modules

- Tailored for specific application needs
- Low handling cost
- Easy service/ upgrade with a wide range of options
- Field installable Plug n' Play and self configuring

Network option modules

- Support for all leading protocols
- Easy installation and commissioning
 - Top cable entry -or-
 - Bottom cable entry (if used you cannot add I/O option modules)
- Built-in Networks: Modbus RTU

Only for AF650 GP and AF600 FP

- Network option modules: Profibus DP, DeviceNet, Ethernet IP, Modbus TCP, Profinet RT
- Additional Option Modules for AF-600 FP: BACnet and LonWorks



Services



GE Drives Services

Your electrical infrastructure's availability, stability, and adaptability are crucial to your business success. Rely on the support professionals who know your systems best! GE's Drives Services offerings range far beyond standard product support: from on-site services for risk-reducing installation and startup, to availability services to help you proactively reduce downtime and meet your service-level commitments. From installation to product retirement, warranty upgrades to remote monitoring, proactive care to 24/7 problem resolution, you can rely on GE's field service organization for all your electrical infrastructure support needs.

Our Service Portfolio

GE services are designed to provide lifelong operation of all our Drives systems. We have a range of service offerings to meet your requirements. We are at home in all areas of industry and business life, specialized in solutions and services for your electrical infrastructure.

Maintenance Programs

The reliability and efficiency of your electrical infrastructure ultimately depends upon the maintenance programs you choose. A maintenance agreement is an opportunity for you to increase productivity and availability while lowering your owning and operating costs. Preventive maintenance helps you find equipment problems before they cause failure, leaving you with fewer repairs and less unscheduled downtime.

We have tailored our service contracts to meet your individual demand by offering three different contract types:

- **BASIC Service**
Annual maintenance, technical support 24/7 and defined intervention time
- **VALUE Service**
BASIC features plus free intervention in case of emergency
- **PREMIUM Service**
VALUE service features plus all material needed for repair

On-Site & Emergency Services

- 24/7 Emergency hotline
- Installation
- Commissioning, start-up
- Repair, upgrade, retrofit
- Assessment, inspection, testing
- Online assistance
- Video live support

Contractual Services

- Maintenance service contracts
- Preventive, planned maintenance
- Upgrade management
- Project & site management
- Consultancy and audits

Parts and Repairs

- Spare parts supply
- Repair services
- Product replacement / return
- Equipment rentals

Contractual Services

- Maintenance service contracts
- Preventive, planned maintenance
- Upgrade management
- Project & site management
- Consultancy and audits

Contract Features

Depending on your requirements, you can choose from following services:

- 24/7 technical support by our local Service Centre
- Guaranteed presence on site within the agreed time (Next Working Day, 12, 6 or 4 hours)
- Annual maintenance visit to analyze the Drive and operational conditions
- Spare parts included for emergency repairs
- Guaranteed 24/7 availability in our stock for most common parts for your Drive
- Preferential pricing for parts and hourly rates

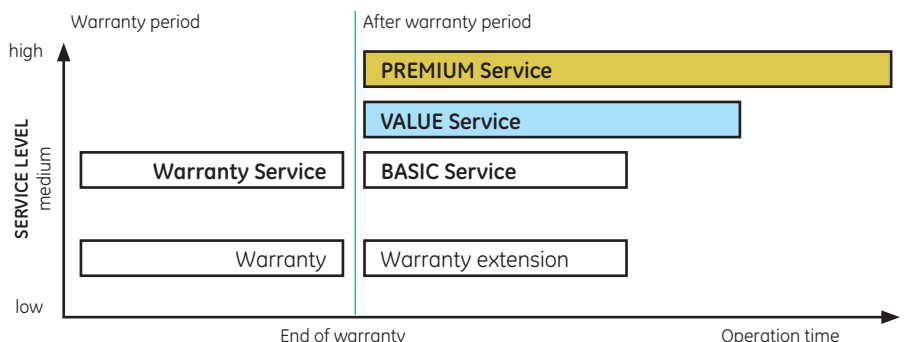

AF-7 series

The new AF-7 series is part of GE's complete range of variable frequency drives and providing more solutions to our customer's needs. These new drives offer significant energy savings in addition to space-saving designs and application features.

New Micro-Drives: AF-70 LP

The AF-70 LP is the new compact drive. Available in both IP20 and IP66, its simple mounting with its basic parameter configuration, make this drive ideal for fans, pumps, and conveyor applications. Simple commissioning, user-friendly keypad control, built-in EMC Filter class B (C1) and application macros with in addition built-in Modbus-RTU and CANopen communication provide optimum solution for control and monitoring systems.

New Fan & Pump Drives: AF-700 FP

With large increase in global energy costs and legislation related to the industrial production of CO2 gases, the need to reduce energy consumption has never been greater. The AF-700 FP is the new Fan and Pump application drive. Available in IP20, IP55 and IP66, built-in EMC Filter class B (C1) and user friendly parameter configuration through its fixed keypad with OLED display. AF-700 FP can be used with environmental sensors to reduce pump or fan speed in air handling or pumping applications without compromising the required output of the system. Built-in Modbus-RTU and BACnet MS/TP communication provides ready integration with industrial network systems.



AF-70 LP – Micro Drives

The Micro Drive AF-70 LP is a compact but powerful and easy to use AC variable frequency drive. The AF-70 LP drive is available in both IP20 and IP66, that includes EMC (RFI) Filter class B (C1) and built-in Brake chopper for 1.5kW and above.

Following models are available:

- Single-phase, 230Vac, from 0.37 to 4kW
- Three-phase, 230Vac, from 0.37 to 11kW
- Three-phase, 400Vac, from 0.75 to 22kW



Features

- Sensorless Vector Control for all Motor Types
- Precise and reliable control for IE2, IE3 & IE4 motors
- For Constant or Variable Torque applications
- Built-in EMC (RFI) Filter class B (C1) (disconnectable)
- PI control
- Dynamic braking chopper from 1.5kW and above
- Dual analogue inputs
- Operates up to 50°C, without derating
- Bluetooth connectivity (optional)
- Built-in Modbus RTU and CANopen communication
- Conformal Coating as standard
- Fan & Pump functionalities such as Flying Start and Fire Override
- Easy to use PC software

Approvals / Marking



UL, cUL

Applications

- Conveyors
- Mixers
- Mills
- Fans such as air curtains, extractors, air handling units
- Pumps such as transfer pumps, dosing pumps
- Swimming pools, Spas, Fountains

Product numbering system diagram

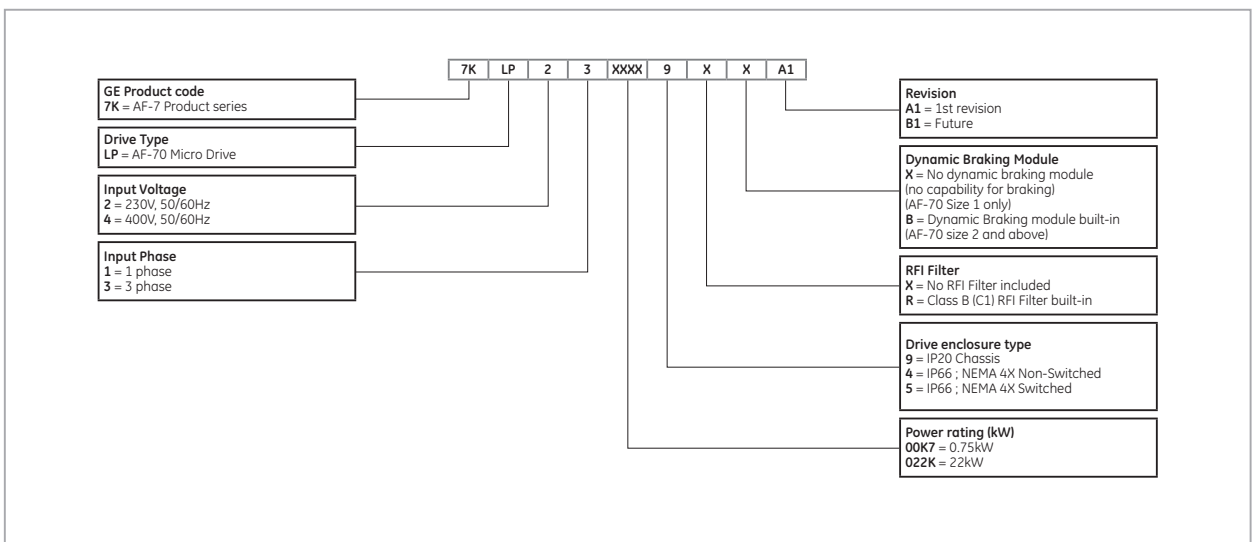

Product number for illustrative purposes only



IP20

230Vac, 1-phase, 50/60Hz input, with EMC (RFI) filter class B (C1)



Output rated power			Dynamic Braking	Cat. No.	Ref. No.	Unit Size
kW	HP	A				
0.37	0.5	2.3	No	7KLP2100K49RXA1	168600	1
0.75	1	4.3	No	7KLP2100K79RXA1	168601	1
1.5	2	7	No	7KLP21001K9RXA1	168602	1
1.5	2	7	Yes	7KLP21001K9RBA1	168603	2
2.2	3	10.5	Yes	7KLP21002K9RBA1	168604	2

230Vac, 3-phase, 50/60Hz input, with EMC (RFI) filter class B (C1)



Output rated power			Dynamic Braking	Cat. No.	Ref. No.	Unit Size
kW	HP	A				
1.5	2	7	Yes	7KLP23001K9RBA1	168611	2
2.2	3	10.5	Yes	7KLP23002K9RBA1	168612	2
4	5	18.0	Yes	7KLP23004K9RBA1	168613	3
5.5	7.5	24	Yes	7KLP23005K9RBA1	168614	3
7.5	10	30	Yes	7KLP23007K9RBA1	168615	4
11	15	46	Yes	7KLP23011K9RBA1	168616	4

400Vac, 3-phase, 50/60Hz input, with EMC (RFI) filter class B (C1)



Output rated power			Dynamic Braking	Cat. No.	Ref. No.	Unit Size
kW	HP	A				
0.75	1	2.2	No	7KLP4300K79RXA1	168626	1
1.5	2	4.1	No	7KLP43001K9RXA1	168627	1
1.5	2	4.1	Yes	7KLP43001K9RBA1	168628	2
2.2	3	5.8	Yes	7KLP43002K9RBA1	168629	2
4	5	9.5	Yes	7KLP43004K9RBA1	168630	2
5.5	7.5	14	Yes	7KLP43005K9RBA1	168631	3
7.5	10	18	Yes	7KLP43007K9RBA1	168632	3
11	15	24	Yes	7KLP43011K9RBA1	168633	3
15	20	30	Yes	7KLP43015K9RBA1	168634	4
18.5	25	39	Yes	7KLP43018K9RBA1	168635	4
22	30	46	Yes	7KLP43022K9RBA1	168636	4

230Vac, 1-phase, 50/60Hz input, without EMC (RFI) filter



Output rated power			Dynamic Braking	Cat. No.	Ref. No.	Unit Size
kW	HP	A				
0.37	0.5	2.3	No	7KLP2100K49XXA1	168605	1
0.75	1	4.3	No	7KLP2100K79XXA1	168606	1
1.5	2	7	No	7KLP21001K9XXA1	168607	1
1.5	2	7	Yes	7KLP21001K9XBA1	168608	2
2.2	3	10.5	Yes	7KLP21002K9XBA1	168609	2
4	5	15.3	Yes	7KLP21004K9XBA1	168610	3

230Vac, 3-phase, 50/60Hz input, without EMC (RFI) filter



Output rated power			Dynamic Braking	Cat. No.	Ref. No.	Unit Size
kW	HP	A				
0.37	0.5	2.3	No	7KLP2300K49XXA1	168617	1
0.75	1	4.3	No	7KLP2300K79XXA1	168618	1
1.5	2	7	No	7KLP23001K9XXA1	168619	1
1.5	2	7	Yes	7KLP23001K9XBA1	168620	2
2.2	3	10.5	Yes	7KLP23002K9XBA1	168621	2
4	5	18.0	Yes	7KLP23004K9XBA1	168622	3
5.5	7.5	24	Yes	7KLP23005K9XBA1	168623	3
7.5	10	30	Yes	7KLP23007K9XBA1	168624	4
11	15	46	Yes	7KLP23011K9XBA1	168625	4

400Vac, 3-phase, 50/60Hz input, without EMC (RFI) filter



Output rated power			Dynamic Braking	Cat. No.	Ref. No.	Unit Size
kW	HP	A				
0.75	1	2.2	No	7KLP4300K79XXA1	168637	1
1.5	2	4.1	No	7KLP43001K9XXA1	168638	1
1.5	2	4.1	Yes	7KLP43001K9XBA1	168639	2
2.2	3	5.8	Yes	7KLP43002K9XBA1	168640	2
4	5	9.5	Yes	7KLP43004K9XBA1	168641	2
5.5	7.5	14	Yes	7KLP43005K9XBA1	168642	3
7.5	10	18	Yes	7KLP43007K9XBA1	168643	3
11	15	24	Yes	7KLP43011K9XBA1	168644	3
15	20	30	Yes	7KLP43015K9XBA1	168645	4
18.5	25	39	Yes	7KLP43018K9XBA1	168646	4
22	30	46	Yes	7KLP43022K9XBA1	168647	4



AF-70 LP

IP66 with frontal switches

230Vac, 1-phase, 50/60Hz input, with EMC (RFI) filter class B (C1)



Output rated power			Dynamic Braking	Cat. No.	Ref. No.	Unit Size
kW	HP	A				
0.37	0.5	2.3	No	7KLP2100K45RXA1	168682	1
0.75	1	4.3	No	7KLP2100K75RXA1	168683	1
1.5	2	7	No	7KLP21001K5RXA1	168684	1
1.5	2	7	Yes	7KLP21001K5RBA1	168685	2
2.2	3	10.5	Yes	7KLP21002K5RBA1	168686	2

230Vac, 3-phase, 50/60Hz input, with EMC (RFI) filter class B (C1)

Output rated power			Dynamic Braking	Cat. No.	Ref. No.	Unit Size
kW	HP	A				
1.5	2	7	Yes	7KLP23001K5RBA1	168693	2
2.2	3	10.5	Yes	7KLP23002K5RBA1	168694	2
4	5	18.0	Yes	7KLP23004K5RBA1	168695	3

400Vac, 3-phase, 50/60Hz input, with EMC (RFI) filter class B (C1)



Output rated power			Dynamic Braking	Cat. No.	Ref. No.	Unit Size
kW	HP	A				
0.75	1	2.2	No	7KLP4300K75RXA1	168702	1
1.5	2	4.1	No	7KLP43001K5RXA1	168703	1
1.5	2	4.1	Yes	7KLP43001K5RBA1	168704	2
2.2	3	5.8	Yes	7KLP43002K5RBA1	168705	2
4	5	9.5	Yes	7KLP43004K5RBA1	168706	2
5.5	7.5	14	Yes	7KLP43005K5RBA1	168707	3
7.5	10	18	Yes	7KLP43007K5RBA1	168708	3

230Vac, 1-phase, 50/60Hz input, **without** EMC (RFI) filter

Output rated power			Dynamic Braking	Cat. No.	Ref. No.	Unit Size
kW	HP	A				
0.37	0.5	2.3	No	7KLP2100K45XXA1	168687	1
0.75	1	4.3	No	7KLP2100K75XXA1	168688	1
1.5	2	7	No	7KLP21001K5XXA1	168689	1
1.5	2	7	Yes	7KLP21001K5XBA1	168690	2
2.2	3	10.5	Yes	7KLP21002K5XBA1	168691	2
4	5	15.3	Yes	7KLP21004K5XBA1	168692	2

230Vac, 3-phase, 50/60Hz input, **without** EMC (RFI) filter

Output rated power			Dynamic Braking	Cat. No.	Ref. No.	Unit Size
kW	HP	A				
0.37	0.5	2.3	No	7KLP2300K45XXA1	168696	1
0.75	1	4.3	No	7KLP2300K75XXA1	168697	1
1.5	2	7	No	7KLP23001K5XXA1	168698	1
1.5	2	7	Yes	7KLP23001K5XBA1	168699	2
2.2	3	10.5	Yes	7KLP23002K5XBA1	168700	2
4	5	18.0	Yes	7KLP23004K5XBA1	168701	3

400Vac, 3-phase, 50/60Hz input, **without** EMC (RFI) filter

Output rated power			Dynamic Braking	Cat. No.	Ref. No.	Unit Size
kW	HP	A				
0.75	1	2.2	No	7KLP4300K75XXA1	168709	1
1.5	2	4.1	No	7KLP43001K5XXA1	168710	1
1.5	2	4.1	Yes	7KLP43001K5XBA1	168711	2
2.2	3	5.8	Yes	7KLP43002K5XBA1	168712	2
4	5	9.5	Yes	7KLP43004K5XBA1	168713	2
5.5	7.5	14	Yes	7KLP43005K5XBA1	168714	3
7.5	10	18	Yes	7KLP43007K5XBA1	168715	3

AF-7 drives

Intro

A

B

C

D

E

F

G

H

New



IP66 *without* frontal switches

230Vac, 1-phase, 50/60Hz input, with EMC (RFI) filter class B (C1)



Output rated power			Dynamic Braking	Cat. No.	Ref. No.	Unit Size
kW	HP	A				
0.37	0.5	2.3	No	7KLP2100K44RXA1	168648	1
0.75	1	4.3	No	7KLP2100K74RXA1	168649	1
1.5	2	7	No	7KLP21001K4RXA1	168650	1
1.5	2	7	Yes	7KLP21001K4RBA1	168651	2
2.2	3	10.5	Yes	7KLP21002K4RBA1	168652	2

230Vac, 3-phase, 50/60Hz input, with EMC (RFI) filter class B (C1)

Output rated power			Dynamic Braking	Cat. No.	Ref. No.	Unit Size
kW	HP	A				
1.5	2	7	Yes	7KLP23001K4RBA1	168659	1
2.2	3	10.5	Yes	7KLP23002K4RBA1	168660	1
4	5	18.0	Yes	7KLP23004K4RBA1	168661	1

400Vac, 3-phase, 50/60Hz input, with EMC (RFI) filter class B (C1)



Output rated power			Dynamic Braking	Cat. No.	Ref. No.	Unit Size
kW	HP	A				
0.75	1	2.2	No	7KLP4300K74RXA1	168668	1
1.5	2	4.1	No	7KLP43001K4RXA1	168669	1
1.5	2	4.1	Yes	7KLP43001K4RBA1	168670	2
2.2	3	5.8	Yes	7KLP43002K4RBA1	168671	2
4	5	9.5	Yes	7KLP43004K4RBA1	168672	2
5.5	7.5	14	Yes	7KLP43005K4RBA1	168673	3
7.5	10	18	Yes	7KLP43007K4RBA1	168674	3

230Vac, 1-phase, 50/60Hz input, *without* EMC (RFI) filter

Output rated power			Dynamic Braking	Cat. No.	Ref. No.	Unit Size
kW	HP	A				
0.37	0.5	2.3	No	7KLP2100K44XXA1	168653	1
0.75	1	4.3	No	7KLP2100K74XXA1	168654	1
1.5	2	7	No	7KLP21001K4XXA1	168655	1
1.5	2	7	Yes	7KLP21001K4XBA1	168656	2
2.2	3	10.5	Yes	7KLP21002K4XBA1	168657	2
4	5	15.3	Yes	7KLP21004K4XBA1	168658	3

230Vac, 3-phase, 50/60Hz input, *without* EMC (RFI) filter

Output rated power			Dynamic Braking	Cat. No.	Ref. No.	Unit Size
kW	HP	A				
0.37	0.5	2.3	No	7KLP2300K44XXA1	168662	1
0.75	1	4.3	No	7KLP2300K74XXA1	168663	1
1.5	2	7	No	7KLP23001K4XXA1	168664	1
1.5	2	7	Yes	7KLP23001K4XBA1	168665	2
2.2	3	10.5	Yes	7KLP23002K4XBA1	168666	2
4	5	18.0	Yes	7KLP23004K4XBA1	168667	3

400Vac, 3-phase, 50/60Hz input, *without* EMC (RFI) filter

Output rated power			Dynamic Braking	Cat. No.	Ref. No.	Unit Size
kW	HP	A				
0.75	1	2.2	No	7KLP4300K74XXA1	168675	1
1.5	2	4.1	No	7KLP43001K4XXA1	168676	1
1.5	2	4.1	Yes	7KLP43001K4XBA1	168677	2
2.2	3	5.8	Yes	7KLP43002K4XBA1	168678	2
4	5	9.5	Yes	7KLP43004K4XBA1	168679	2
5.5	7.5	14	Yes	7KLP43005K4XBA1	169000	3
7.5	10	18	Yes	7KLP43007K4XBA1	168681	3



AF-70 LP

Options and accessories

Remote Keypad



Description	Cat. No.	Ref. No.
Remote mounting keypad on enclosure doors. Kit includes gasket and 3 meters' cable. Keypad is rated IP54.		
Remote LED Keypad with RJ45 Cable, unit size 1 & 2	7KRMKPD1	168830
Remote OLED Keypad with RJ45 Cable, for unit size 3 and above	7KRMKPD2	168831

Communication Modules

Description	Cat. No.	Ref. No.
Profibus External Gateway & Cables	7KGTWPDP	168800
DeviceNET External Gateway & Cables	7KGTWDEV	168801
Bluetooth Interface	7KBTI	168810
USB PC Connection Kit	7KUSB	168811

Input/Output Modules

Description	Cat. No.	Ref. No.
Dual Relay Output Card	7KLPRLY	168832
HVAC Relay Output Card	7KLPHVAC	168834

AF-7 drives

Intro

A

B

C

D

E

F

G

H

New



Basic wiring diagrams

IP20 & IP66 (Nema 4X) Non-Switched Units

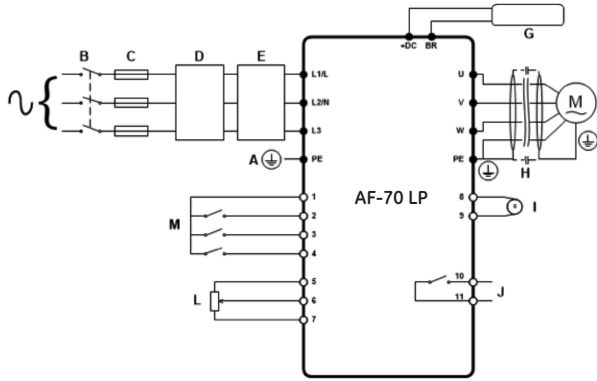

IP66 (Nema 4X) Switched Units

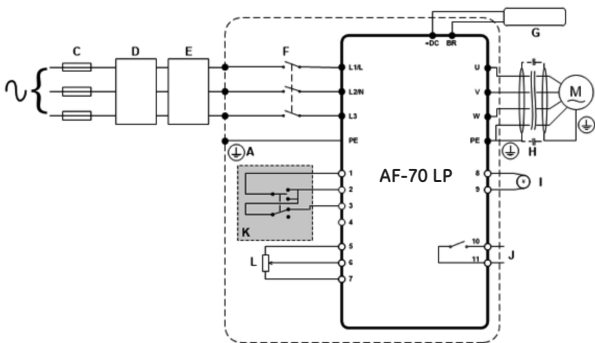

- | | |
|---|---|
| A | Protective Earth (PE) Connection |
| B | Incoming Power Connection |
| C | Fuse / Circuit Breaker Selection |
| D | Optional Input Choke |
| E | Optional External EMC Filter |
| F | Internal Disconnect / Isolator |
| G | Optional Brake Resistor |
| H | Motor Connection |
| I | Analog Output |
| J | Relay Output |
| K | Using the REV/0/FWD Selector Switch (Switched Version Only) |
| L | Analog Inputs |
| M | Digital Inputs |

Basic control terminal

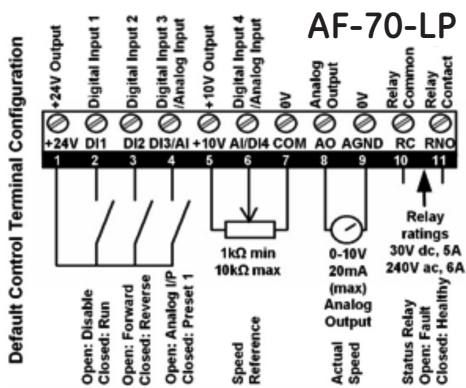

Specifications

Environmental conditions

Enclosure	IP20 and IP66
Installation location	Do not install in locations where product could be exposed to dust, corrosive gas, inflammable gas, oil mist, vapor, water drops or direct sunlight. There must be no salt in the atmosphere. Condensation must not be caused by sudden changes in temperature. For use at altitudes of 3280 ft. (1000 m) or less without derating.
Ambient temperature	Operating: -10 to +50°C, without derating Storage: -40 to +60°C
Ambient humidity	Humidity: 5 to 95% (non condensing)
Vibration	1.0G according EN 61800-5-1

Standards

Approvals	CE, UL, cUL
EMC Directive	2004/108/EC Category C1 according EN 61800-3:2004
Machinery Directive	2006/42/EC

Input power supply

Rated Input AC voltage	200 - 240 Vac, 1-phase, 50-60 Hz, +/- 10% V 200 - 240 Vac, 3-phase, 50-60 Hz, +/- 10% V 380 - 480 Vac, 3-phase, 50-60 Hz, +/- 10% V
Maximum voltage imbalance	3% of rated supply voltage
Rated Input frequency	48 - 62Hz
Displacement power factor	> 0.98
Switching on input power supply	Maximum twice/minute, evenly spaced

Output

Rated output voltage	0 - 100 % of supply voltage
Output frequency	0 - 500Hz, with 0.1Hz resolution
Accel/decel times	0.01 - 600 seconds
Overload current rating	150% for 60 seconds 175% for 2.5 seconds
Efficiency	>98%

Control

Control method	Sensorless Vector Speed Control PM Vector Control BLDC Control Synchronous Reluctance
Switching frequency	4 - 32kHz
Braking	Motor Flux Braking
Jump Frequency	Single point, adjustable
Operation method	Analog signal: 0 - 10V 10 - 0V 0 - 20mA 20 - 0mA 4 - 20mA 20 to 4mA Digital signal: Keypad potentiometer Modbus RTU (9.6 - 115.2 kbps selectable) CANopen (125 - 1000 kbps)

Control: Inputs/Outputs

Supply	24Vdc, 100mA 10Vdc, 5mA for potentiometer
4 programmable inputs	2 Digital 2 Analog / Digital selectable
Digital inputs	8 - 30Vdc, internal or external supply Response time < 4ms
Analog inputs	Resolution: 12 bits Response time < 4ms Accuracy: ± 2% full scale
2 Programmable outputs	1 Analog / Digital 1 Relay
Relay outputs	250Vac, 30Vdc max Switching current capacity: 6A AC, 5A DC
Analog outputs	0 - 10V



Dimensional drawings

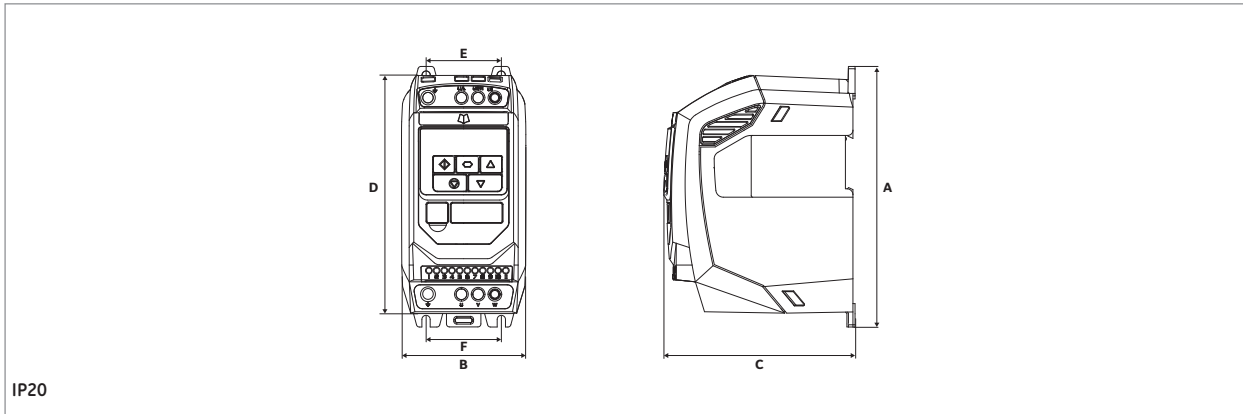

Drive Unit Size	Input voltage	Power rating	A		B		C		D		E		F		Weight Kg
			mm	in	mm	in	mm	in	mm	in	mm	in	mm	in	
1	240V	0.37 to 1.5kW	173	6.81	83	3.27	123	4.84	162	6.38	50	1.97	50	1.97	1.0
	400V	0.75 to 1.5kW													
2	240V	1.5 to 2.2kW	221	8.70	110	4.33	150	5.91	209	8.23	63	2.48	63	2.48	1.7
	400V	1.5 to 4kW													
3	240V	4 to 5.5kW	261	10.28	131	5.16	175	6.89	247	9.72	80	3.15	80	3.15	3.2
	400V	5.5 to 11kW													
4	240V	7.5 to 11kW	420	16.54	171	6.73	212	8.35	400	15.75	125	4.92	125	4.92	9.1

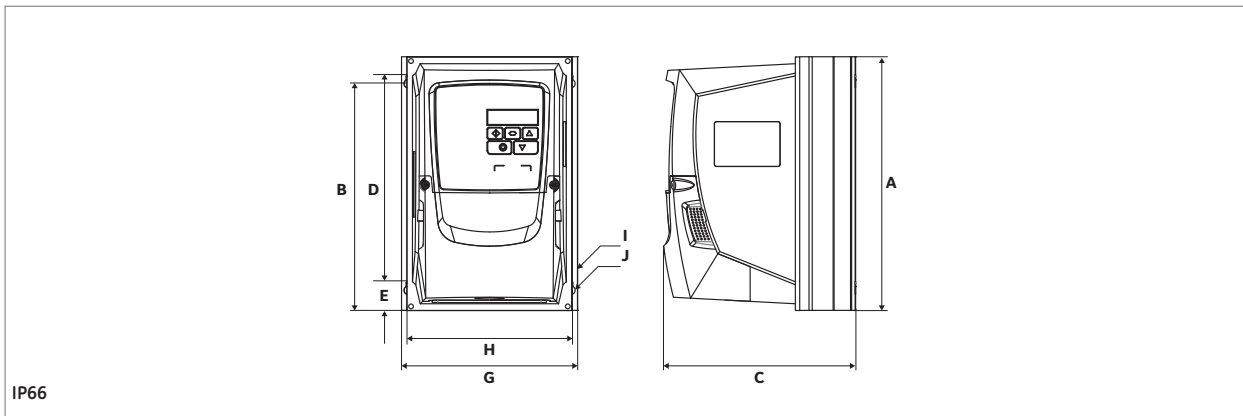

Drive Size	Input voltage	Power rating	A		B		D		E		F		G		H		I		J		Weight	
			mm	in	mm	in	mm	in	mm	in	mm	in	mm	in	mm	in	mm	in	mm	in	kg	lb
1	240V	0.37 to 1.5kW	232.0	9.13	207.0	8.15	189.0	7.44	25.0	0.98	179.0	7.05	161.0	6.34	148.5	5.85	4.0	0.16	8.0	0.31	3.1	6.8
	400V	0.75 to 1.5kW																				
2	240V	1.5 to 2.2kW	257.0	10.12	220.0	8.67	200.0	7.87	28.5	1.12	187.0	7.36	188.0	7.40	176.0	6.93	4.2	0.17	8.5	0.33	4.1	9.0
	400V	1.5 to 4kW																				
3	240V	4kW	310.0	12.20	276.5	10.89	251.5	9.90	33.4	1.31	252	9.92	211.0	8.30	197.5	7.78	4.2	0.17	8.5	0.33	7.6	16.7
	400V	5.5 to 7.5kW																				

Dimensions in mm (inch = mm x 0.03937) - Weight in kg (lb = kg x 2.2046)



Dimensional drawings

Keypad

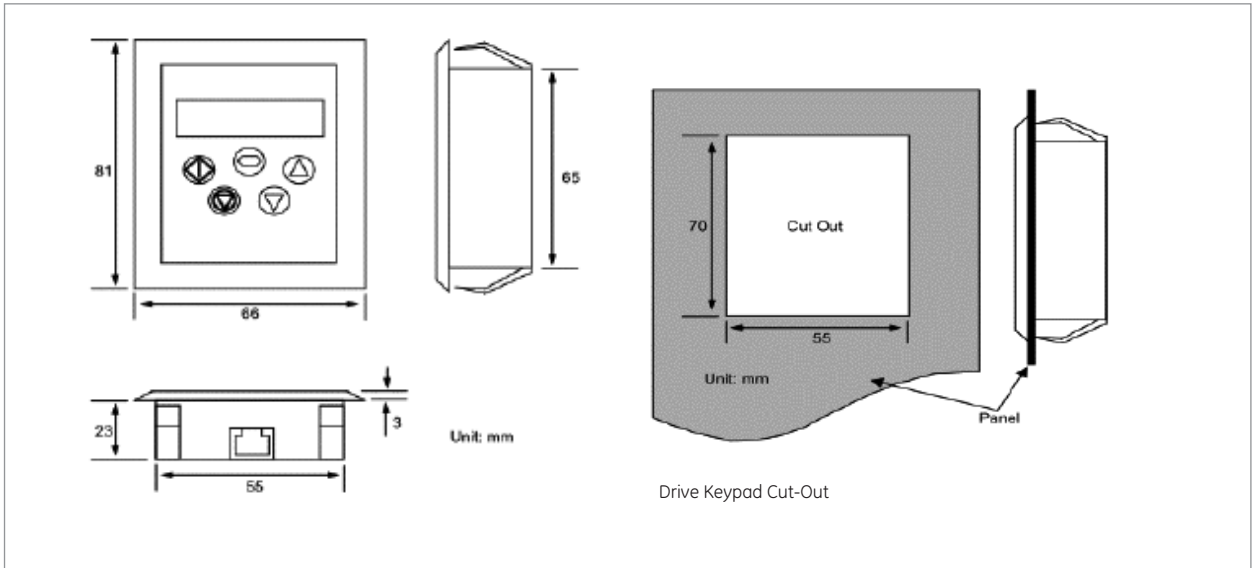

Description	Cat. No.	Ref. No.
Remote LED Keypad with RJ45 Cable, unit size 1 & 2	7KRMKPD1	168830

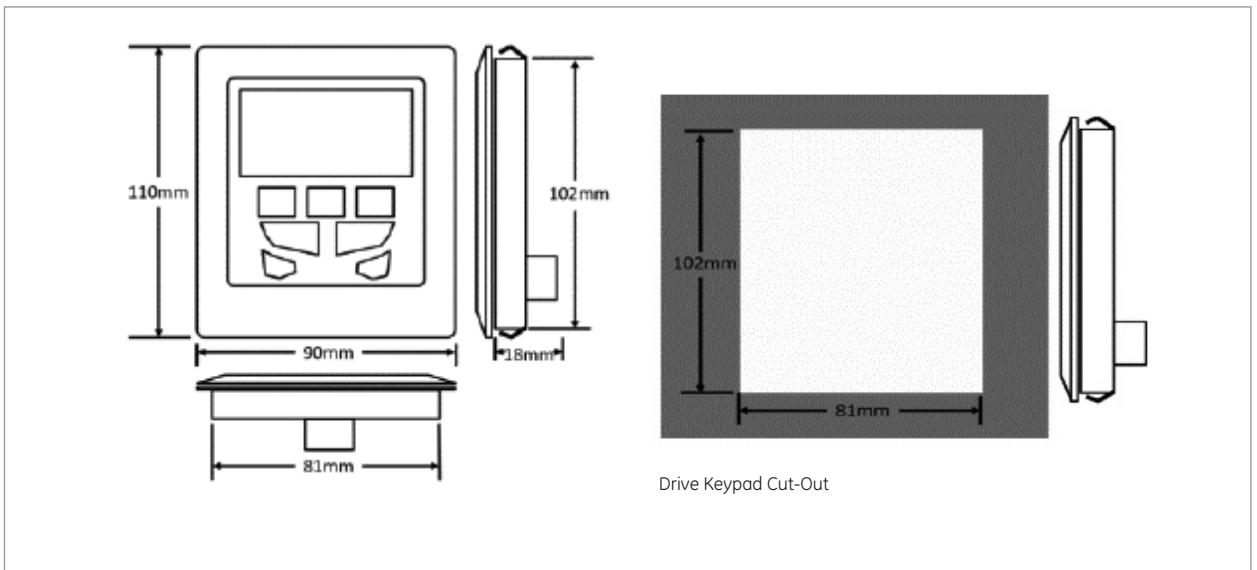

Description	Cat. No.	Ref. No.
Remote OLED Keypad with RJ45 Cable, for unit size 3 and above	7KRMKPD2	168831

Dimensions in mm (inch = mm x 0.03937) - Weight in kg (lb = kg x 2.2046)



Everything is under control

AF-700 FP – Fan & Pump Drive

The AF-700 FP is dedicated for Fan and Pump applications. The AF-700 FP drive is available in IP20, IP55 and IP66, that includes EMC (RFI) Filter class B (C1), Safe Torque Off (STO) input, Modbus RTU and BACnet communications as standard.

Following models are available:

- Single-phase, 230Vac, from 0.75 to 2.2kW
- Three-phase, 230Vac, from 0.75 to 75kW
- Three-phase, 400Vac, from 0.75 to 250kW
- Three-phase, 600Vac, from 0.75 to 110kW

Features

- Sensorless Vector Control for all Motor Types
- Suitable with IE2, IE3 & IE4 motors
- Dedicated features for HVAC and Water applications
- OLED Multi Language Display
- Built-in EMC (RFI) Filter class B (C1) (disconnectable)
- Reduced Harmonic Distortion (THDi) (according EN 61000-3-12)
- Safe Torque Off (STO) input as standard
- Local Mains Switch for unit sizes 4 and 5 (15 to 45kW @ 400Vac)
- Bluetooth connectivity (optional)
- Built-in Modbus RTU and BACnet communication
- Conformal Coating as standard
- Optional communication modules: Profibus, Profinet, EtherCat, BACnet IP, Modbus TCP, Ethernet IP and DeviceNet
- Better heat management with panel through kits
- Easy to use PC software

Approvals / Marking



UL, cUL

Applications

Fan

HVAC, cooling towers, VAV, supply and return, exhaust, fume hood, make-up air, induced and forced draft, furnace temperature control.

Pump

Chilled water, pressure boosting, cooling tower, wastewater, chiller, irrigation, hydro-storage.

Product numbering system diagram

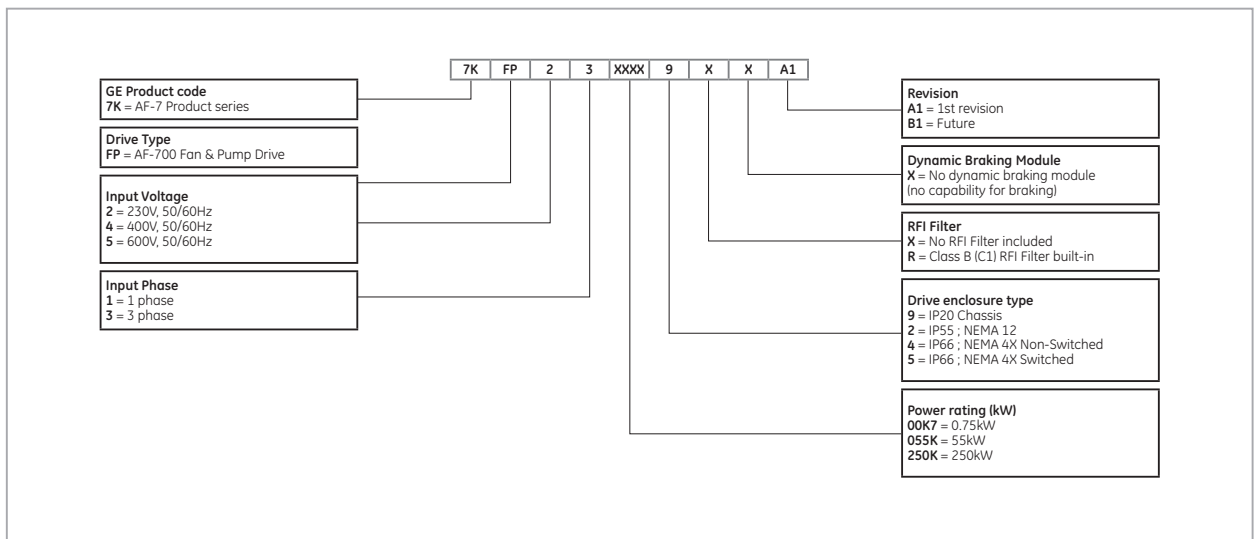

Product number for illustrative purposes only



IP20

230Vac, 1-phase, 50/60Hz input, with EMC (RFI) filter class B (C1)



Output rated power			Cat. No.	Ref. No.	Unit Size
kW	HP	A			
0.75	1	4.3	7KFP2100K79RXA1	168716	2
1.5	2	7	7KFP21001K9RXA1	168717	2
2.2	3	10.5	7KFP21002K9RXA1	168718	2

230Vac, 3-phase, 50/60Hz input, with EMC (RFI) filter class B (C1)



Output rated power			Cat. No.	Ref. No.	Unit Size
kW	HP	A			
0.75	1	4.3	7KFP2300K79RXA1	168719	2
1.5	2	7	7KFP23001K9RXA1	168720	2
2.2	3	10.5	7KFP23002K9RXA1	168721	2
4	5	18	7KFP23004K9RXA1	168722	3
5.5	7.5	24	7KFP23005K9RXA1	168723	3
7.5	10	30	7KFP23007K9RXA1	168724	4
11	15	46	7KFP23011K9RXA1	168725	4
15	20	61	7KFP23015K9RXA1	168726	5
18.5	25	72	7KFP23018K9RXA1	168727	5
22	30	90	7KFP23022K9RXA1	168728	5

400Vac, 3-phase, 50/60Hz input, with EMC (RFI) filter class B (C1)



Output rated power			Cat. No.	Ref. No.	Unit Size
kW	HP	A			
0.75	1	2.2	7KFP4300K79RXA1	168729	2
1.5	2	4.1	7KFP43001K9RXA1	168730	2
2.2	3	5.8	7KFP43002K9RXA1	168731	2
4	5	9.5	7KFP43004K9RXA1	168732	2
5.5	7.5	14	7KFP43005K9RXA1	168733	3
7.5	10	18	7KFP43007K9RXA1	168734	3
11	15	24	7KFP43011K9RXA1	168735	3
15	20	30	7KFP43015K9RXA1	168736	4
18.5	25	39	7KFP43018K9RXA1	168737	4
22	30	46	7KFP43022K9RXA1	168738	4
30	40	61	7KFP43030K9RXA1	168739	5
37	50	72	7KFP43037K9RXA1	168740	5
45	60	90	7KFP43045K9RXA1	168741	5
200	300	370	7KFP43200K9RXA1	168742	8
250	350	450	7KFP43250K9RXA1	168743	8

575Vac, 3-phase, 50/60Hz input, with EMC (RFI) filter class B (C1)



Output rated power			Cat. No.	Ref. No.	Unit Size
kW	HP	A			
0.75	1	2.1	7KFP5300K79RXA1	168744	2
1.5	2	3.1	7KFP53001K9RXA1	168745	2
2.2	3	4.1	7KFP53002K9RXA1	168746	2
4	5	6.5	7KFP53004K9RXA1	168747	2
5.5	7.5	9	7KFP53005K9RXA1	168748	2
7.5	10	12	7KFP53007K9RXA1	168749	3
11	15	17	7KFP53011K9RXA1	168750	3
15	20	22	7KFP53015K9RXA1	168751	3
18.5	25	28	7KFP53018K9RXA1	168752	4
22	30	34	7KFP53022K9RXA1	168753	4
30	40	43	7KFP53030K9RXA1	168754	4
37	50	54	7KFP53037K9RXA1	168755	5
45	60	65	7KFP53045K9RXA1	168756	5



AF-700 FP

IP55

230Vac, 3-phase, 50/60Hz input, with EMC (RFI) filter class B (C1)



Output rated power			Cat. No.	Ref. No.	Unit Size
kW	HP	A			
7.5	10	30	7KFP23007K2RXA1	168907	4
11	15	46	7KFP23011K2RXA1	168908	4
15	20	61	7KFP23015K2RXA1	168909	5
18.5	25	72	7KFP23018K2RXA1	168910	5
22	30	90	7KFP23022K2RXA1	168911	5
30	40	110	7KFP23030K2RXA1	168912	6
37	50	150	7KFP23037K2RXA1	168913	6
45	60	180	7KFP23045K2RXA1	168914	6
55	75	202	7KFP23055K2RXA1	168915	7
75	100	248	7KFP23075K2RXA1	168916	7

400Vac, 3-phase, 50/60Hz input, with EMC (RFI) filter class B (C1)



Output rated power			Cat. No.	Ref. No.	Unit Size
kW	HP	A			
15	20	30	7KFP43015K2RXA1	168917	4
18.5	25	39	7KFP43018K2RXA1	168918	4
22	30	46	7KFP43022K2RXA1	168919	4
30	40	61	7KFP43030K2RXA1	168920	5
37	50	72	7KFP43037K2RXA1	168921	5
45	60	90	7KFP43045K2RXA1	168922	5
55	75	110	7KFP43055K2RXA1	168923	6
75	100	150	7KFP43075K2RXA1	168924	6
90	125	180	7KFP43090K2RXA1	168925	6
110	150	202	7KFP43110K2RXA1	168926	7
132	200	240	7KFP43132K2RXA1	168927	7
160	250	302	7KFP43160K2RXA1	168928	7

575Vac, 3-phase, 50/60Hz input, with EMC (RFI) filter class B (C1)



Output rated power			Cat. No.	Ref. No.	Unit Size
kW	HP	A			
15	20	22	7KFP53015K2RXA1	168929	4
18.5	25	28	7KFP53018K2RXA1	168930	4
22	30	34	7KFP53022K2RXA1	168931	4
30	40	43	7KFP53030K2RXA1	168932	4
37	50	54	7KFP53037K2RXA1	168933	5
45	60	65	7KFP53045K2RXA1	168934	5
55	75	78	7KFP53055K2RXA1	168935	6
75	100	105	7KFP53075K2RXA1	168936	6
90	125	130	7KFP53090K2RXA1	168937	6
110	150	150	7KFP53110K2RXA1	168938	6

AF-7 drives

Intro

A

B

C

D

E

F

G

H

New



IP66 with frontal switches

230Vac, 1-phase, 50/60Hz input, with EMC (RFI) filter class B (C1)



Output rated power			Cat. No.	Ref. No.	Unit Size
kW	HP	A			
0.75	1	4.3	7KFP2100K75RXA1	168779	2
1.5	2	7	7KFP21001K5RXA1	168780	2
2.2	3	10.5	7KFP21002K5RXA1	168781	2

230Vac, 3-phase, 50/60Hz input, with EMC (RFI) filter class B (C1)



Output rated power			Cat. No.	Ref. No.	Unit Size
kW	HP	A			
0.75	1	4.3	7KFP2300K75RXA1	168782	2
1.5	2	7	7KFP23001K5RXA1	168783	2
2.2	3	10.5	7KFP23002K5RXA1	168784	2
4	5	18	7KFP23004K5RXA1	168785	3
5.5	7.5	24	7KFP23005K5RXA1	168786	3

400Vac, 3-phase, 50/60Hz input, with EMC (RFI) filter class B (C1)



Output rated power			Cat. No.	Ref. No.	Unit Size
kW	HP	A			
0.75	1	2.2	7KFP4300K75RXA1	168787	2
1.5	2	4.1	7KFP43001K5RXA1	168788	2
2.2	3	5.8	7KFP43002K5RXA1	168789	2
4	5	9.5	7KFP43004K5RXA1	168790	2
5.5	7.5	14	7KFP43005K5RXA1	168791	3
7.5	10	18	7KFP43007K5RXA1	168792	3
11	15	24	7KFP43011K5RXA1	168793	3

575Vac, 3-phase, 50/60Hz input, with EMC (RFI) filter class B (C1)



Output rated power			Cat. No.	Ref. No.	Unit Size
kW	HP	A			
0.75	1	2.1	7KFP5300K75RXA1	168900	2
1.5	2	3.1	7KFP53001K5RXA1	168901	2
2.2	3	4.1	7KFP53002K5RXA1	169002	2
4	5	6.5	7KFP53004K5RXA1	169003	2
5.5	7.5	9	7KFP53005K5RXA1	168904	2
7.5	10	12	7KFP53007K5RXA1	168905	3
11	15	17	7KFP53011K5RXA1	168906	3



AF-700 FP

IP66 *without* frontal switches

230Vac, 1-phase, 50/60Hz input, with EMC (RFI) filter class B (C1)



Output rated power			Cat. No.	Ref. No.	Unit Size
kW	HP	A			
0.75	1	4.3	7KFP2100K74RXA1	168757	2
1.5	2	7	7KFP21001K4RXA1	168758	2
2.2	3	10.5	7KFP21002K4RXA1	168759	2

230Vac, 3-phase, 50/60Hz input, with EMC (RFI) filter class B (C1)



Output rated power			Cat. No.	Ref. No.	Unit Size
kW	HP	A			
0.75	1	4.3	7KFP2300K74RXA1	168760	2
1.5	2	7	7KFP23001K4RXA1	168761	2
2.2	3	10.5	7KFP23002K4RXA1	168762	2
4	5	18	7KFP23004K4RXA1	168763	3
5.5	7.5	24	7KFP23005K4RXA1	168764	3

400Vac, 3-phase, 50/60Hz input, with EMC (RFI) filter class B (C1)



Output rated power			Cat. No.	Ref. No.	Unit Size
kW	HP	A			
0.75	1	2.2	7KFP4300K74RXA1	168765	2
1.5	2	4.1	7KFP43001K4RXA1	168766	2
2.2	3	5.8	7KFP43002K4RXA1	168767	2
4	5	9.5	7KFP43004K4RXA1	168768	2
5.5	7.5	14	7KFP43005K4RXA1	168769	3
7.5	10	18	7KFP43007K4RXA1	168770	3
11	15	24	7KFP43011K4RXA1	168771	3

575Vac, 3-phase, 50/60Hz input, with EMC (RFI) filter class B (C1)



Output rated power			Cat. No.	Ref. No.	Unit Size
kW	HP	A			
0.75	1	2.1	7KFP5300K74RXA1	168772	2
1.5	2	3.1	7KFP53001K4RXA1	168773	2
2.2	3	4.1	7KFP53002K4RXA1	168774	2
4	5	6.5	7KFP53004K4RXA1	168775	2
5.5	7.5	9	7KFP53005K4RXA1	168776	2
7.5	10	12	7KFP53007K4RXA1	168777	3
11	15	17	7KFP53011K4RXA1	168778	3

AF-7 drives

Intro

A

B

C

D

E

F

G

H

New



Options and accessories

Remote Keypad



Description	Cat. No.	Ref. No.
Remote mounting keypad on enclosure doors. Kit includes gasket and 3 meters' cable. Keypad is rated IP54.		
Remote LED Keypad with RJ45 Cable, unit size 1 & 2	7KRMKPD1	168830
Remote OLED Keypad with RJ45 Cable, for unit size 3 and above	7KRMKPD2	168831

Communication Modules

Description	Cat. No.	Ref. No.
EtherCAT communication Module	7KFPECAT	168802
Profibus DP communication Module	7KFPPDP	168803
Profinet communication Module	7KFPPRT	168804
Ethernet IP communication Module	7KFPEIP	168805
DeviceNet communication Module	7KFPEDEV	168806
BACnet IP communication Module	7KFPBAC	168807
Modbus TCP communication Module	7KFPMBTCP	168808
Bluetooth Interface	7KBTI	168810
USB PC Connection Kit	7KUSB	168811

Input/Output Modules

Description	Cat. No.	Ref. No.
Extended I/O Module	7KFPGPIO	168837
Cascade Control Module	7KFPCCTRL	168838

Local Mains Switch

Description	Cat. No.	Ref. No.
Local Mains Switch for unit size 4	7KFPMSW	168839
Local Mains Switch for unit size 5	7KFPMSW	168840

Panel Through Kit

Description	Cat. No.	Ref. No.
Panel Through Kit for unit size 4	7KFPPTK4	168844
Panel Through Kit for unit size 5	7KFPPTK5	168845
Panel Through Kit for unit size 6	7KFPPTK6	168846
Panel Through Kit for unit size 7	7KFPPTK7	168847



Basic wiring diagrams

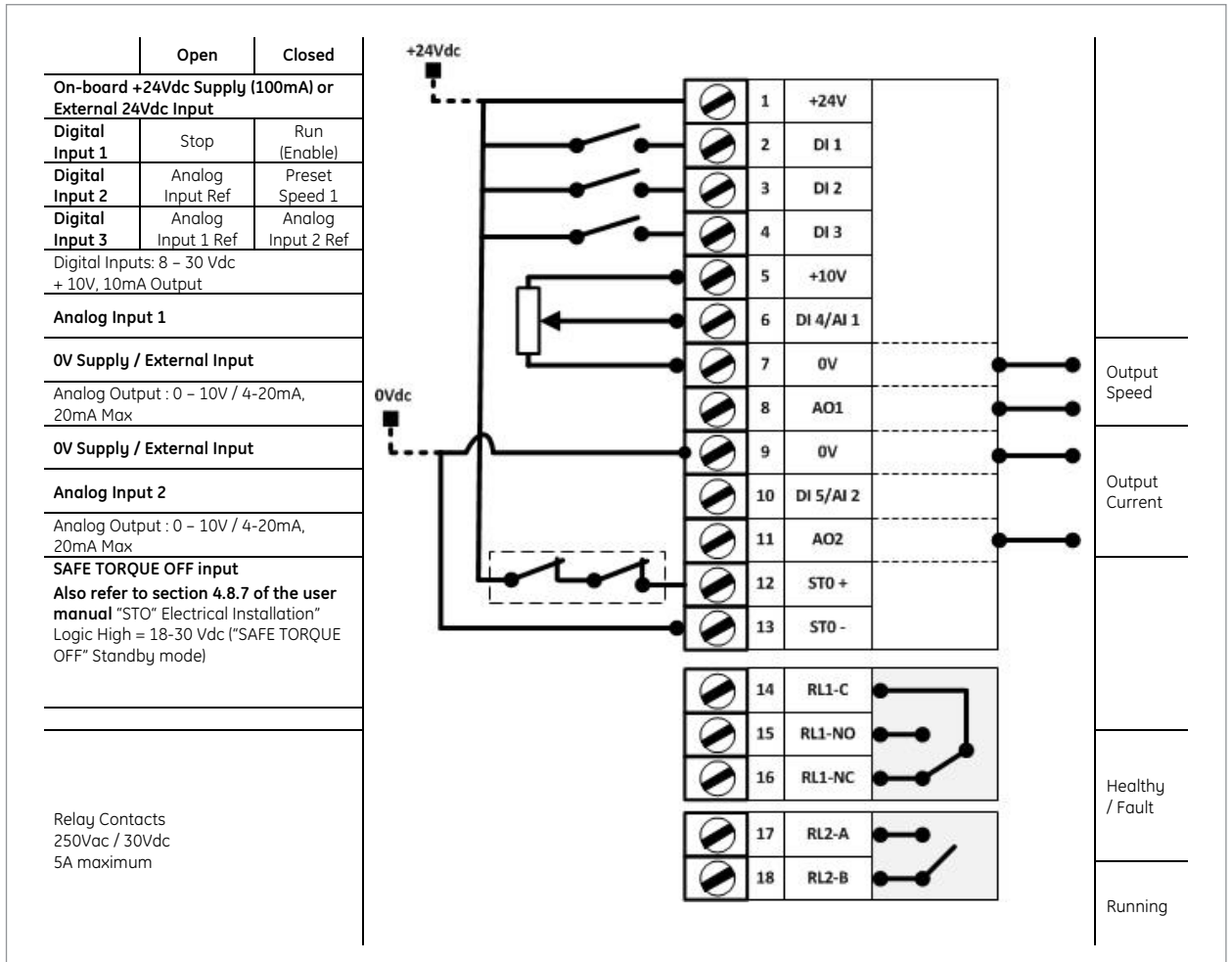

Output Speed

Output Current

Healthy / Fault

Running



Specifications

Environmental conditions

Enclosure	IP20, IP55 and IP66
Installation location	Do not install in locations where product could be exposed to dust, corrosive gas, inflammable gas, oil mist, vapor, water drops or direct sunlight. There must be no salt in the atmosphere. Condensation must not be caused by sudden changes in temperature. For use at altitudes of 3280 ft. (1000 m) or less without derating.
Ambient temperature	Operating: -10 to +50°C Storage: -40 to +60°C
Ambient humidity	Humidity: 5 to 95% (non condensing)
Vibration	1.0G according EN 61800-5-1

Standards

Approvals	CE, UL, cUL
EMC Directive	2004/108/EC Category C1 according EN 61800-3:2004
Low Voltage Directive	2014/35/EU
Harmonics	IEC 61000-3-12

Input power supply

Rated Input AC voltage	200 - 240 Vac, 1-phase, 50-60 Hz, +/- 10% V 200 - 240 Vac, 3-phase, 50-60 Hz, +/- 10% V 380 - 480 Vac, 3-phase, 50-60 Hz, +/- 10% V 500 - 600 Vac, 3-phase, 50-60 Hz, +/- 10% V
Maximum voltage imbalance	3% of rated supply voltage
Rated Input frequency	48 - 62Hz
Displacement power factor	> 0.98
Switching on input power supply	Maximum twice/minute, evenly spaced

Output

Rated output voltage	0 - 100 % of supply voltage
Output frequency	0 - 250Hz, with 0.1Hz resolution
Accel/decel times	0.1 - 600 seconds
Overload current rating	110% for 60 seconds 165% for 4 seconds
Efficiency	>98%

Control

Control method	sensorless Vector Speed Control PM Vector Control BLDC Control Synchronous Reluctance
Switching frequency	4 - 32kHz
Jump Frequency	Single point, adjustable
Operation method	Analog signal: 0 - 10V or 10 - 0V -10V to +10V 0 - 20mA or 20 - 0mA 4 - 20mA or 20 to 4mA Digital signal: Keypad potentiometer Modbus RTU (9.6 - 115.2 kbps selectable) BACnet MS/TP (9.6 - 76.8 kbps selectable)

Control: Inputs/Outputs

Supply	24Vdc, 100mA 10Vdc, 5mA for potentiometer
5 programmable inputs	3 Digital 2 Analog / Digital selectable
Digital inputs	8 - 30Vdc, internal or external supply Response time < 4ms
Analog inputs	Resolution: 12 bits Response time < 4ms Accuracy: < 1% full scale
PTC input	Motor PTC / Thermistor with trip level: 3kΩ
2 Programmable outputs	1 Analog / Digital 1 Relay
Relay outputs	250Vac, 30Vdc max Switching current capacity: 6A AC, 5A DC
Analog outputs	0 - 10V or 10 - 0V -10V to +10V 0 - 20mA or 20 - 0mA 4 - 20mA or 20 - 4mA

Diagnostics

Fault memory	Last 4 trips Logging of data prior to trip for diagnostic purposes: Output current, Drive temperature and DC Bus voltage
Maintenance	Indicator with user adjustable maintenance interval; includes Service life monitoring
Monitoring	Hours run meter kWh meters Cooling fan run time

Application features

Load monitoring	Over Torque protection (fan / bump blocked) Under Torque protection (broken belt / shaft) Pump blockage detection with cleaning and autotuned function, user configurable
Fire mode	Bidirectional ; selectable speed setpoint (fixed, PID, analog or fieldbus)
PID control	Internal PID controller Multi-setpoint Standby / Sleep mode Boost function
Multi-pump control	Control of fixed speed assist pumps (need optional Cascade control module) Control of duty, assist and standby variable speed pumps via internal Master - Slave network; Automatic changeover on fault and on time; Fully redundant
Pump cleaning	Bi-directional pump cleaning cycle operation ; adjustable



AF-700 FP

Dimensional drawings

Drives

AF-7 drives

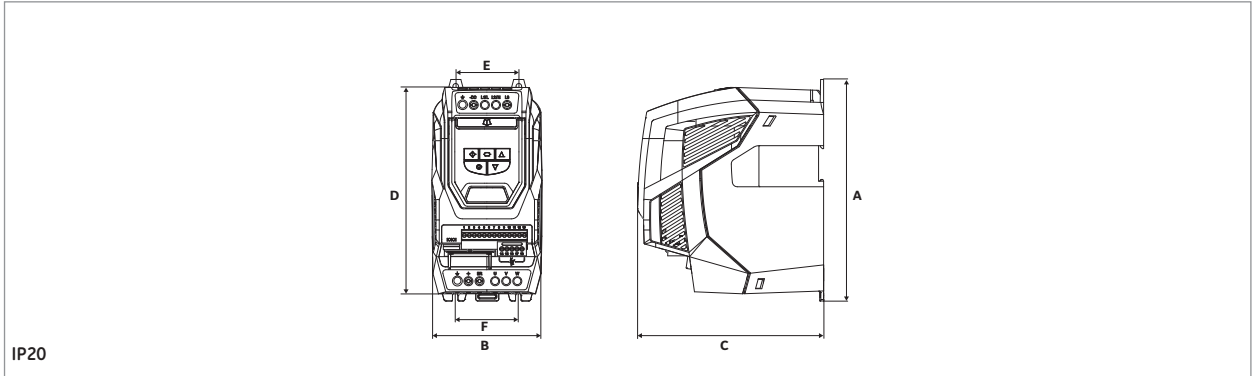

Unit Size	A		B		C		D		E		F		Weight	
	mm	in	mm	in	mm	in	mm	in	mm	in	mm	in	Kg	lb
2	221	8.70	110	4.33	185	7.28	209	8.23	63	2.48	63	2.48	1.8	4.0
3	261	10.28	131	5.16	205	8.07	247	9.72	80	3.15	80	3.15	3.5	7.7
4	418	16.46	160	6.30	240	9.45	400	15.75	125	4.92	125	4.92	9.2	20.3
5	486	19.13	222	8.74	260	10.24	-	-	175	6.89	175	6.89	18.1	39.9

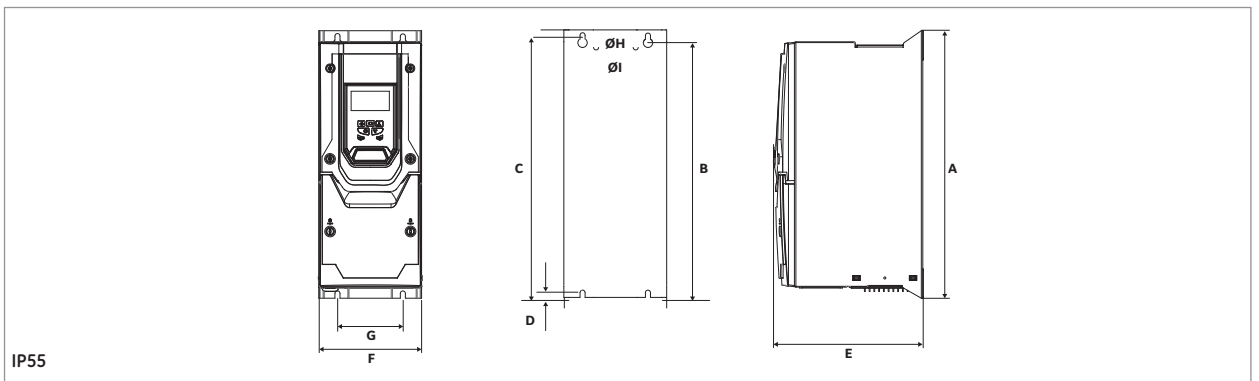

Unit Size	Input voltage	Power rating	A		B		D		E		F		G		H		I		Weight	
			mm	in	mm	in	mm	in	mm	in	mm	in	mm	in	mm	in	mm	in	kg	lb
4	450	17.32	428	16.46	433	16.65	8	0.31	252	9.92	171	6.73	110	4.33	8.5	0.33	15	0.59	12	25.4
5	540	21.26	515	20.28	520	20.47	8	0.31	270	10.63	235	9.25	175	6.89	8.5	0.33	15	0.59	23.1	50.9
6	865	34.06	830	32.68	840	33.07	10	0.39	330	12.99	330	12.99	200	7.87	11.0	0.44	22	0.87	55	121.2
7	1280	50.39	1245	49.02	1255	49.41	10	0.39	360	14.17	330	12.99	200	7.87	11.0	0.44	22	0.87	89	196.2

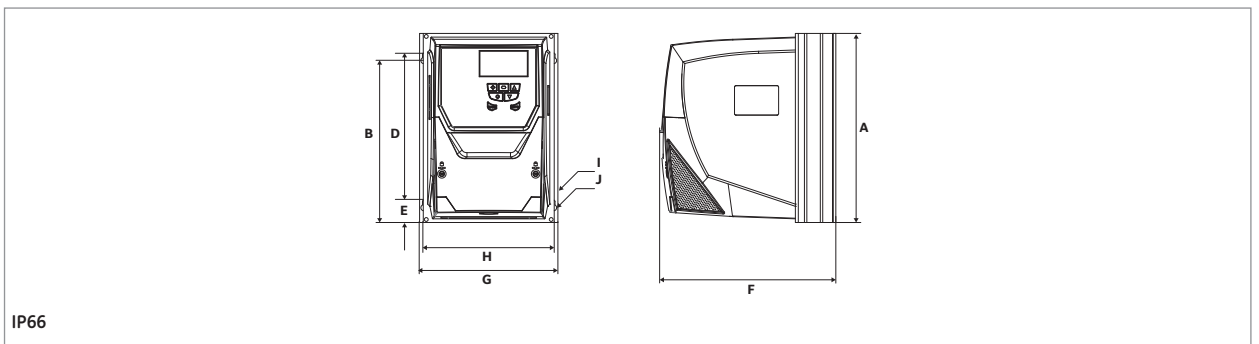

Unit Size	Input voltage	Power rating	A		B		D		E		F		G		H		I		Weight	
			mm	in	mm	in	mm	in	mm	in	mm	in	mm	in	mm	in	mm	in	kg	lb
2A	257	10.12	220	8.67	200	7.87	28.4	1.12	239	9.41	188	7.40	176	6.93	4.2	0.17	8.5	0.33	4.8	10.6
2B	257	10.12	220	8.67	200	7.87	28.4	1.12	260	10.24	188	7.40	176	6.93	4.2	0.17	8.5	0.33	5.5	12.1
3	310	12.20	276.5	10.89	251.5	9.90	33.4	1.31	273	10.75	211	8.29	198	7.78	4.2	0.17	8.5	0.33	8.5	18.7

Dimensions in mm (inch = mm x 0.03937) - Weight in kg (lb = kg x 2.2046)



Intro

A

B

C

D

E

F

G

H

New

Dimensional drawings

Keypad

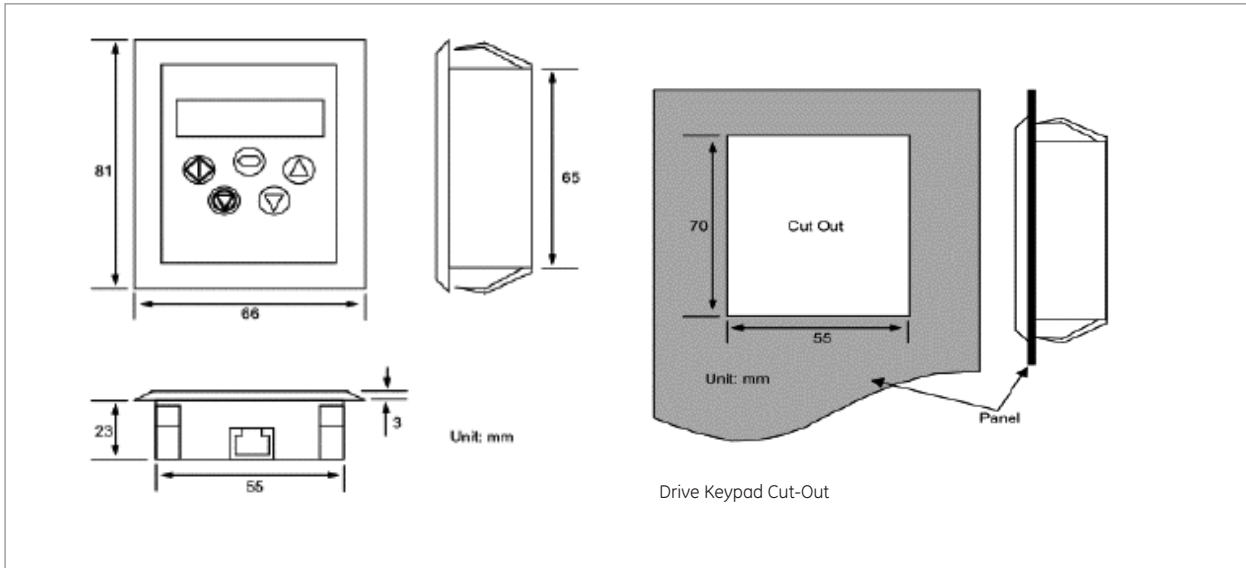

Description	Cat. No.	Ref. No.
Remote LED Keypad with RJ45 Cable, unit size 1 & 2	7KRMKPD1	168830

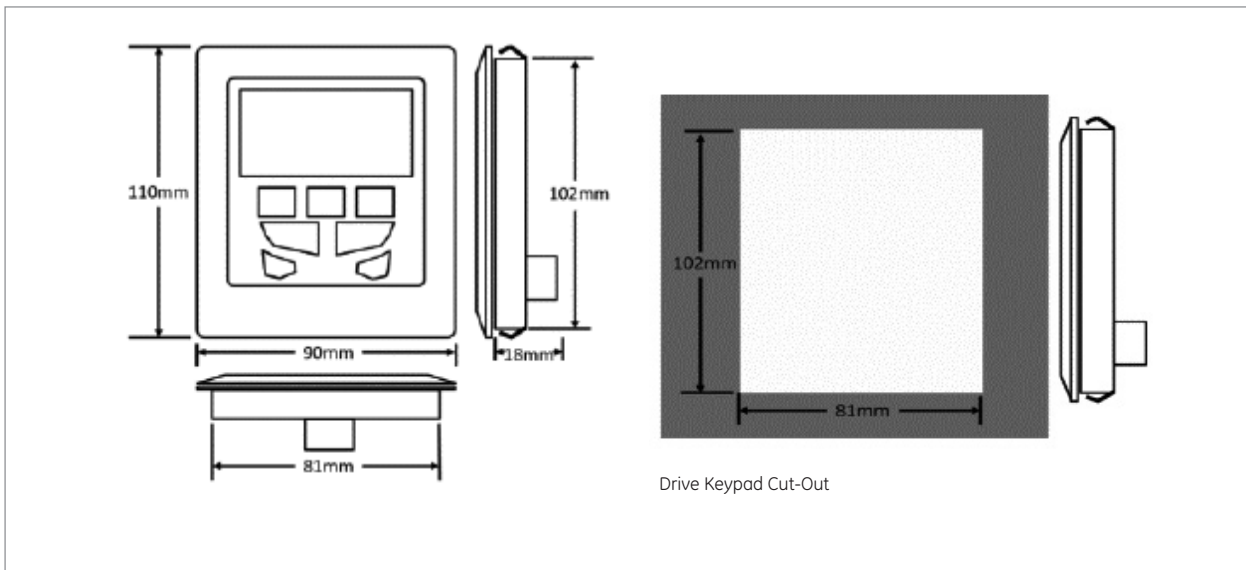

Description	Cat. No.	Ref. No.
Remote OLED Keypad with RJ45 Cable, for unit size 3 and above	7KRMKPD2	168831

AF-60 LP - Micro Drives

The Micro Drive AF-60 LP is a compact but powerful and easy to use AC variable frequency drive.

The drive is available in its standard configuration that includes built-in Brake chopper for 1.5kW and above, single-turn potentiometer for speed reference and LCD keypad display that can be remotely mounted.

Following models are available:

- Single-phase, 230Vac, from 0.18 to 2.2kW
- Three-phase, 230Vac, from 0.25 to 3.7kW
- Three-phase, 400Vac, from 0.37 to 22kW



Features

Ready to start from the beginning

- Self-protecting features
- 150% current overload up to 1 minute
- "Pick up" start (catch a spinning motor)
- Potentiometer on keypad
- Keypad is hot pluggable and can be password protected
- RS485 communication, Modbus protocol
- RFI class A1 filter built-in
- Dynamic brake incorporated from 1.5kW
- High level functions, PID for feedback systems, mechanical brake control for lifts
- Easy to use PC software
- Integrated logic control, PLC

Built-in durability

- Robust housing (IP20) protects the drive and allows side-by-side mounting
- Conformal coated circuit boards and high quality capacitors maximize uptime
- Intelligent heat management leads to long life

Built-in simplicity speeds installation and set-up

- Installation and set-up immediate
- Wiring diagram, template and quick guide
- DIN-rail kit optional, to 2.2kW (unit size M1 and M2)

Approvals / Marking



UL, cUL, C-Tick

Applications

- Fans
- Pumps
- Mixers
- Conveyors
- Material handling
- Industrial machinery, including: agitators, lathes, spinning machines, machine tools, packaging equipment, plastics and woodworking

Product numbering system diagram

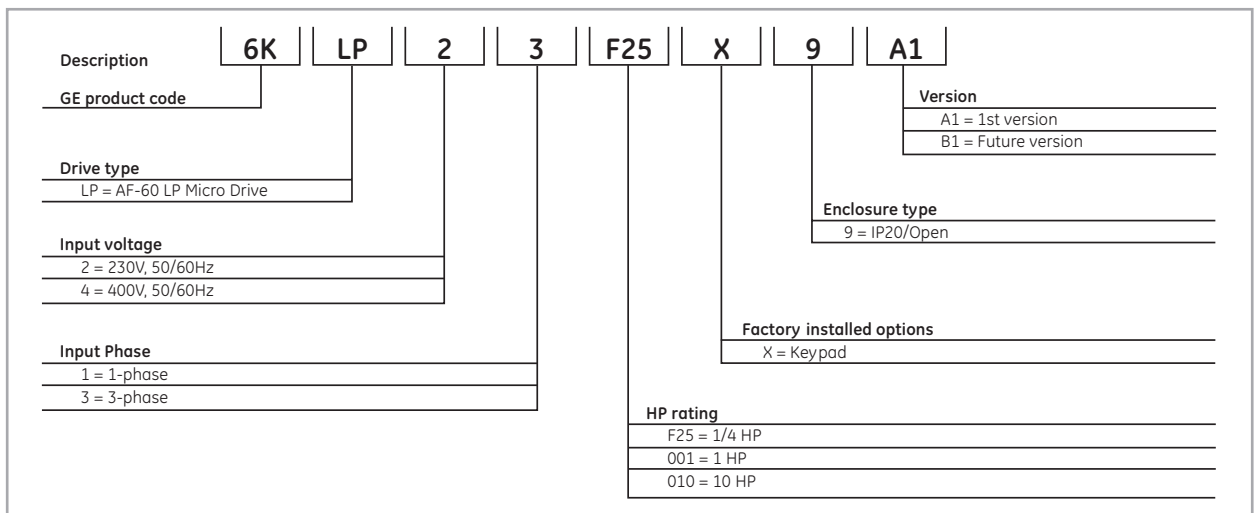

Product number for illustrative purposes only



IP20

230 Vac, 1-phase, 50/60 Hz input

Nominal motor ratings		Cat. No.	Ref. No.	Unit Size	Efficiency (%) ⁽¹⁾	Losses (W) ⁽¹⁾	IP21 kit	DIN-rail mounting kit
Power kW	Current A							
0.18	1.2	6KLP21F25X9A1	404774	M1	94.5	15.5	NEMA1ACLP1	RMACLP1
0.37	2.2	6KLP21F50X9A1	404775	M1	95.6	25.0	NEMA1ACLP1	RMACLP1
0.75	4.2	6KLP21001X9A1	404776	M1	96.0	44.0	NEMA1ACLP1	RMACLP1
1.5	6.8	6KLP21002X9A1	404777	M2	96.7	67.0	NEMA1ACLP2	RMACLP1
2.2	9.6	6KLP21003X9A1	404778	M3	97.1	85.1	NEMA1ACLP3	N/A

230 Vac, 3-phase, 50/60 Hz input

0.25	1.5	6KLP23F33X9A1	404779	M1	94.9	20.0	NEMA1ACLP1	RMACLP1
0.37	2.2	6KLP23F50X9A1	404780	M1	95.8	24.0	NEMA1ACLP1	RMACLP1
0.75	4.2	6KLP23001X9A1	404781	M1	96.3	39.5	NEMA1ACLP1	RMACLP1
1.5	6.8	6KLP23002X9A1	404782	M2	97.2	57.0	NEMA1ACLP2	RMACLP1
2.2	9.6	6KLP23003X9A1	404783	M3	97.4	77.1	NEMA1ACLP3	N/A
3.7	15.2	6KLP23005X9A1	404784	M3	97.4	122.8	NEMA1ACLP3	N/A

400 Vac, 3-phase, 50/60 Hz input

0.37	1.2	6KLP43F50X9A1	404785	M1	95.5	25.5	NEMA1ACLP1	RMACLP1
0.75	2.2	6KLP43001X9A1	404786	M1	96.0	43.5	NEMA1ACLP1	RMACLP1
1.5	3.7	6KLP43002X9A1	404787	M2	97.2	56.5	NEMA1ACLP2	RMACLP1
2.2	5.3	6KLP43003X9A1	404788	M2	97.1	81.5	NEMA1ACLP2	RMACLP1
4	9	6KLP43005X9A1	404789	M3	98.0	133.5	NEMA1ACLP3	N/A
5.5	12	6KLP43007X9A1	404790	M3	98.0	166.8	NEMA1ACLP3	N/A
7.5	15.5	6KLP43010X9A1	404791	M3	98.0	217.5	NEMA1ACLP3	N/A
11	23	6KLP43015X9A1	404792	M4	97.4	342	NEMA1ACLP4	N/A
15	31	6KLP43020X9A1	404793	M4	97.4	454	NEMA1ACLP4	N/A
18.5	37	6KLP43025X9A1	404794	M5	98.0	428	NEMA1ACLP5	N/A
22	43	6KLP43030X9A1	404795	M5	97.9	520	NEMA1ACLP5	N/A

Brake chopper is included with 1.5kW drives and above
 (1) At rated load conditions



Options and accessories



Remote mounting kit for keypad

Remote mounting kit for mounting keypad on enclosure doors.
Kit includes gasket, mounting brackets, and cable. Keypad is rated IP21.

Description	Cat. No.	Ref. No.
Remote mounting kit for keypad cable (3m)	RMKYPDACLP1	404797

DIN-rail mounting kit

This adapter can be used to mount AF-60 LP Micro Drives at 0.75kW and below to 35mm DIN-rail.

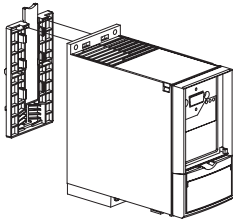

Description	Cat. No.	Ref. No.
DIN-rail mounting kit for unit size M1 or M2 ⁽¹⁾	RMACLP1	404806

(1) Please note that these DIN-rail mounting kits only include bottom cover.

IP21 kit

This kit can be mounted to the IP20 protected AF-60 LP Micro Drives to provide IP21 protection.

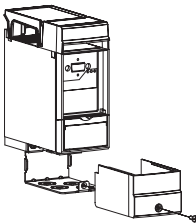

Description	Cat. No.	Ref. No.
For 0.75kW and below drives (unit size M1)	NEMA1ACL1	404798
For 1.5kW at 230V, 2.2kW at 400V and below drives (unit size M2)	NEMA1ACL2	404799
For 2.2kW at 230V, 3.7kW at 400V and above drives (unit size M3)	NEMA1ACL3	404800
For 11kW and 15kW at 400V drives (unit size M4)	NEMA1ACL4 ⁽²⁾	404801
For 18.5kW and 22kW at 400V drives (unit size M5)	NEMA1ACL5 ⁽²⁾	404802

(2) Please note that these IP21 kits only include bottom cover.

De-coupling plate kit

For EMC applications and strain relief for drive wiring.

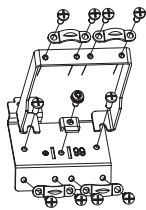

Description	Cat. No.	Ref. No.
For 1.5kW at 230V, 2.2kW at 400V and below drives (unit size M1 and M2)	DEPLTACL1	404804
For 2.2kW at 230V, 3.7kW at 400V and above drives (unit size M3)	DEPLTACL2	404805
For 11kW at 400V and above drives (unit size M4 and M5)	DEPLTACL3	404803

Basic wiring diagrams

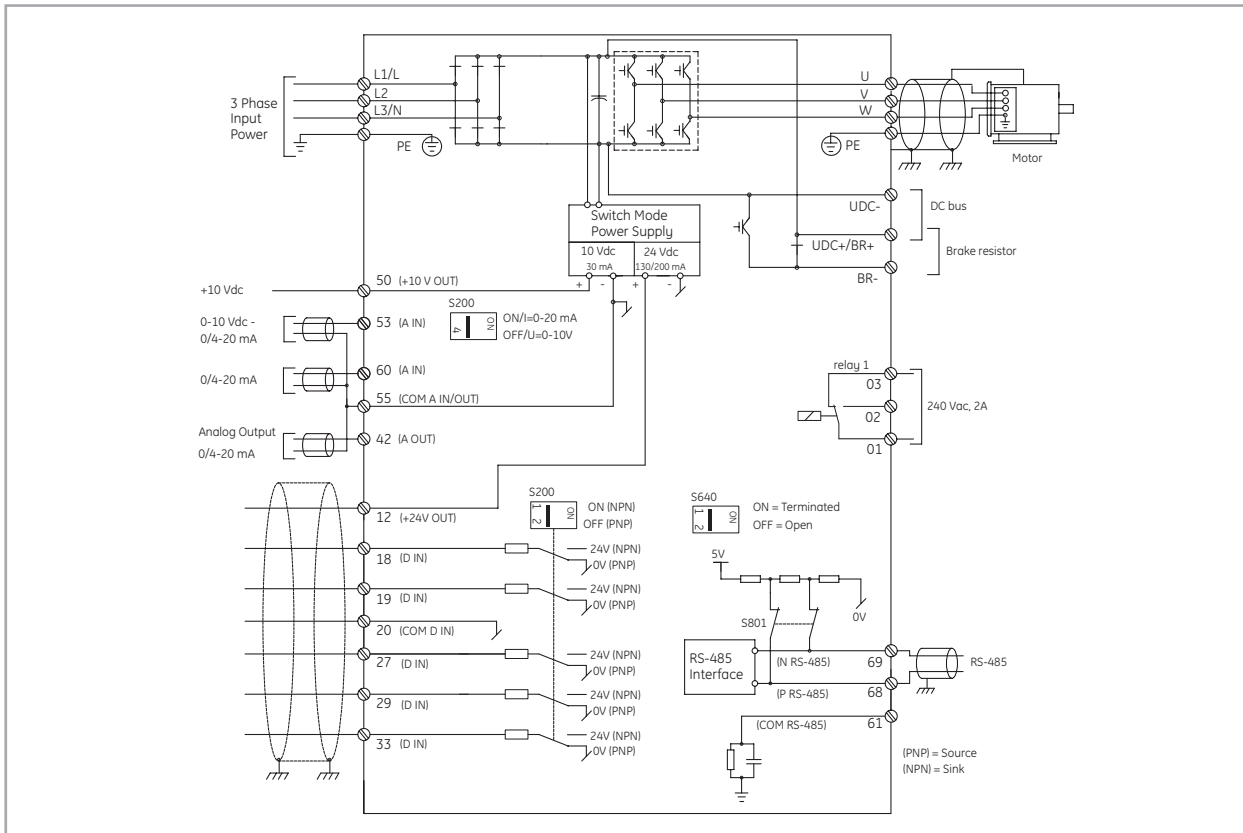

Basic control terminal (PNP configuration and drive factory default settings)

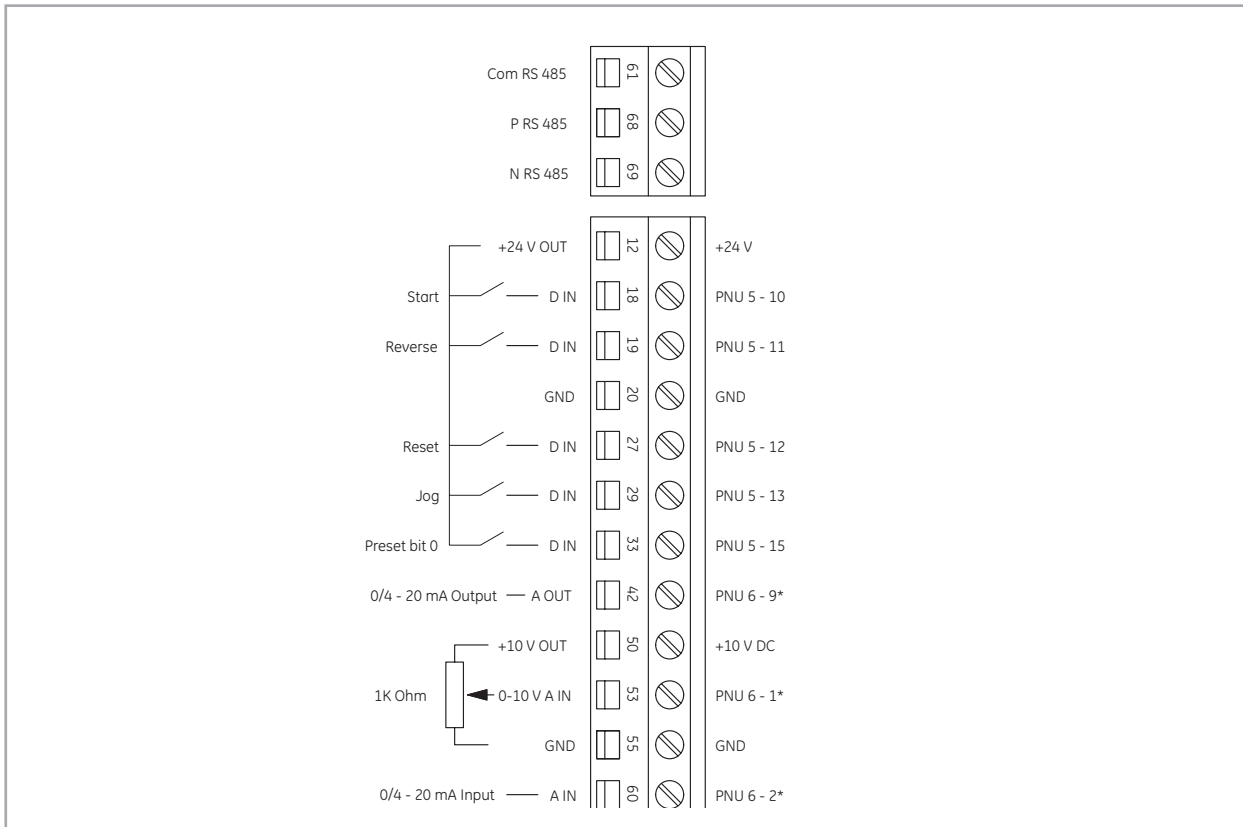

Specifications

Environmental conditions

Enclosure	IP20 (IP21 with optional kit)
Installation location	For use at altitudes of (1000m) or less without derating.
Ambient temperature	-10° to +50°C for above 45°C, there will be derating; please consult GE
Ambient humidity	5 to 95% RH (non-condensing)
Vibration	1.0G
Storage temperature	-25° to 65°C

Standards

Approvals	CE, UL, cUL, and C-Tick Suitable for use on a circuit capable of delivering not more than 100,000 rms symmetrical amperes for 230V and 400V. WEEE and RoHS Compliant
-----------	--

Input power supply

Rated Input AC voltage	200-240 Vac, 1-phase, 50-60 Hz, +/- 10% V 200-240 Vac, 3-phase, 50-60 Hz, +/- 10% V 380-480 Vac, 3-phase, 50-60 Hz, +/- 10% V
Maximum voltage imbalance	3% of rated supply voltage
True power factor	> 0.4 nominal at rated load
Displacement power factor	> 0.98
Switching on input power supply	Maximum twice/minute
Environment according to EN60664-1	Overvoltage category III/pollution degree 2

Output

Rated output voltage	0-100% of supply voltage
Output frequency	0-200 Hz (Adv. Vector Control Plus Mode), 0-400 Hz (Volts/Hertz Mode)
Switching on output	Unlimited
Accel/decel times	0.05-3600 seconds
Overload current rating	150% of drive rated current for 1 minute

Control

Control method	Sinusoidal PWM Control (V/Hz with torque vector control)
Switching frequency select	2, 4, 8, 12, 16 kHz
Operation method	Keypad operation: Hand, Off, Auto Digital Input: Programmable for Start/Stop, Forward/Reverse, Jog Timer operation: Stop after predetermined time frame Link operation: RS-485 Modbus RTU
Frequency reference setting	Up or Down buttons on keypad or external reference
Analog input	Built in potentiometer 0-10 Vdc analogue input 4-20 mA analogue input
Preset speeds	8 presets via digital inputs
Link operation	Drive RS-485 or Modbus RTU
Second reference setting	Switch from speed reference 1 to reference 2 via digital input
Trim reference setting	Available for speed reference offset via potentiometer, voltage input, or current input
Acceleration/deceleration time	0.05-3600 seconds (two acceleration and deceleration rates are selectable via digital inputs. Acceleration and deceleration patterns can be selected from linear or S-curve)
DC injection braking	Starting frequency: 0.0-400 Hz Braking level: 0-150% of rated current Braking time: 0.0-60.0 seconds
Frequency limit	0-400 Hz
Jump frequency control	Two jump (or skip) frequencies via parameter set to avoid mechanical vibration
Jogging operation	Operation via On key or digital input (Fwd or Rev)
Auto-restart after power failure	Restarts the drive without stopping after instantaneous power failure
Slip compensation	Maintains motor at constant speed with load fluctuations
Energy savings	Controls output voltage to minimize motor loss during constant speed operation
Start mode function	This functionality smoothly catches a spinning motor

Logic controller (LC)

Logic controller events	Over 23 types of programmable events
Comparators	Array of 4 comparators
Timers	Array of 3 timers, adjustable from 0.0 to 3600 sec
Logic rules	Array of 4 boolean logic rules
Logic controller states	Array of 20 logic controller action states

Process controller (PID)

Feedback select	No function, analogue input 1, analogue input 2, pulse input, local bus reference
Control	Normal or inverse
Anti windup	Disabled or enabled
Start speed	0.0-200 Hz
Proportional gain	0.00-10.00
Integral gain	0.10-9999 seconds
Feed forward factor	0-400%
On reference bandwidth	0-200%

Indication

LEDs	Green - drive is on Yellow - indicates a warning Red - indicates an alarm
Monitor Units Available	Frequency, current, voltage, power, horsepower, % load, speed, or time

Trip codes

2	Live zero error
4	Line phase loss
7	DC overvoltage
8	DC undervoltage
9	Drive overload
10	Motor overtemperature
11	Motor thermistor overtemperature
12	Torque limit
13	Overcurrent
14	Ground fault
16	Short circuit
17	Control word timeout
25	Brake resistor short-circuited
27	Brake chopper short-circuited
28	Brake check
29	Power board overtemperature
30	Missing U phase
31	Missing V phase
32	Missing W phase
38	Internal fault
47	Control voltage fault
51	Auto tune check - wrong motor parameters
52	Auto tune low inom - motor current is too low
59	Current limit
63	Mechanical brake low
80	Drive restored to factory settings

Monitoring parameters available

Power	kW
Power	HP
Motor voltage	V
Frequency	Hz
Motor current	A
Frequency	%
Motor thermal	%
DC link voltage	V
Drive current	A
Drive max current	A
Logic controller state	ON/OFF



Dimensional drawings

Micro drives

Unit size	Nominal motor power ratings (kW)			Height (mm)			Width (mm)		Depth (mm)	Weight kg
	230 V 1ph	230 V 3ph	400 V 3ph	A	A (including decoupling plate)	a	B	b	C	
M1	0.18 - 0.75	0.25 - 0.75	0.37 - 0.75	150	205	140.4	70	55	148	1.1
M2	1.5	1.5	1.5 - 2.2	176	230	166.4	75	59	168	1.6
M3	2.2	2.2 - 3.7	4 - 7.5	239	294	226	90	69	194	3.0
M4	-	-	11 - 15	292	347.5	272.4	125	97	249	6.0
M5	-	-	18.5 - 22	335	387.5	315	165	140	256	9.5

Micro drive keypad

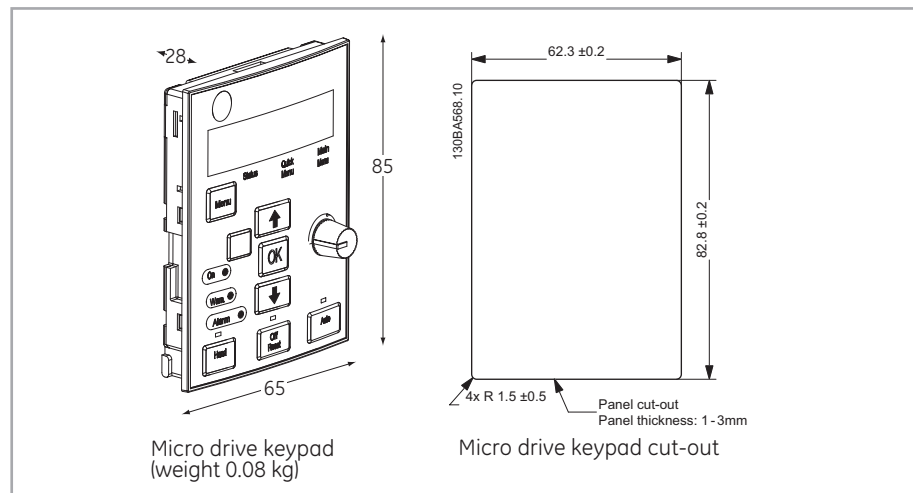
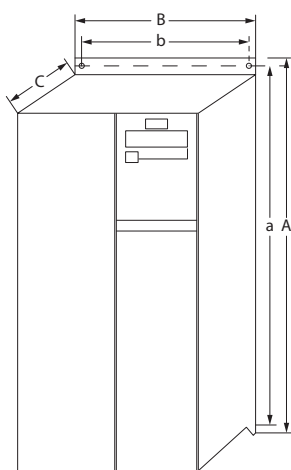

Micro drive keypad
(weight 0.08 kg)

Micro drive keypad cut-out

Note: Please allow 5 cm between drives with field installed IP21 kits. Also, please consult the relevant AF-6 Series drives Operating Instructions for recommended clearance above and below each drive rating.

DIN-rail mounting kit for 0.75kW and below drives (unit size M1 and M2)

Cat. No.	Ref. No.	A (mm)	B (mm)	C (mm)
RMACLP1	404806	60	129	13.5

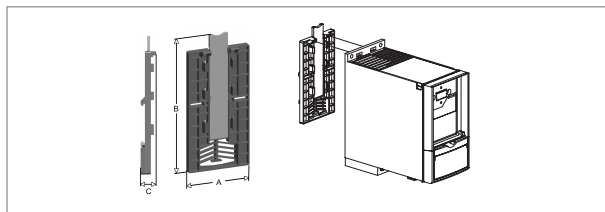

IP21 field installed kit – top

Cat. No.	Ref. No.	A (mm)	B (mm)	C (mm)	D (mm)
NEMA1ACL1	404798	72	43	151	8
NEMA1ACL2	404799	77	43	172	8
NEMA1ACL3	404800	92	43	199	8

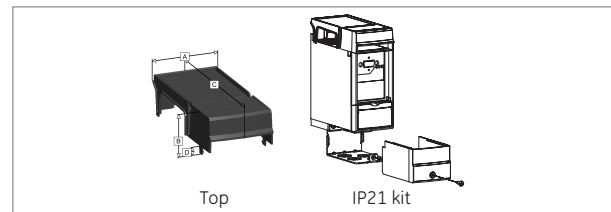

De-coupling plate kit

Cat. No.	Ref. No.	A (mm)	B (mm)	C (mm)	D (mm)	E (mm)
DEPLTACL1	404804	70	52	100	14	22.6
DEPLTACL2	404805	70	52	N/A	14	22.6

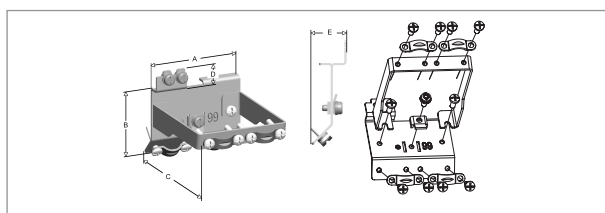

IP21 field installed kit – bottom

Cat. No.	Ref. No.	A (mm)	B (mm)	C (mm)	D (mm)
NEMA1ACL1	404798	70	55	107	8
NEMA1ACL2	404799	75	55	114	8
NEMA1ACL3	404800	90	55	121	8

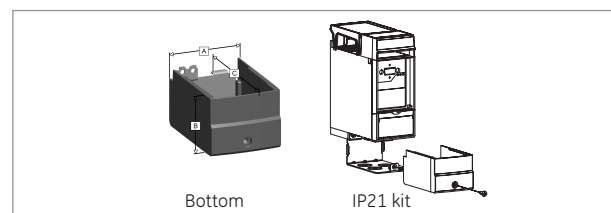

Dimensions in mm (inch = mm x 0.03937) - Weight in kg (lb = kg x 2.2046)



AF-650 GP - General Purpose Drives



The AF-650 GP general purpose drive is a powerful, flexible and easy to use drive with many standard features. It is ideally suited for both heavy duty and light duty applications.

The drive is available in its standard configuration that includes IP20 or IP00 chassis, LCD keypad display that can be remote mounted, DC link reactors, built-in Modbus RTU and RFI class A2 filter. Available in IP 55 and IP 66 enclosures.

Following models are available:

- Three-phase, 230Vac, from 0.25 to 45kW
- Three-phase, 400Vac, from 0.37 to 1000kW
- Three-phase, 690Vac, from 11 to 1200kW

Features

- Self-protecting features
- Other available configurations: RFI class A1/B1 filter, braking chopper and conformal coating.
- Configurations are available in IP55 and IP66
- RFI class A2 filter and DC link reactor as standard configuration
- Duality of power, Heavy or Light Duty
- 150% current overload for 1 minute (Heavy Duty)
- 110% current overload for 1 minute (Light Duty)
- Hot pluggable, illuminated LCD display, unit indications, rotation direction indication, trended charts display speed, torque, current, full alarm messages & descriptions
- Speed and process PID controls
- Integrated logic control, PLC
- Flying start (catch a spinning motor)
- Precise stop function
- Safe Stop/Safe Torque function built-in (SIL 2)
- Advanced brake control
- 24V encoder feedback built-in
- Easy to use PC software
- Built-in communication networks for ModBus RTU
- Optional protocols: Profibus DP, Profinet, ModBus TPC/IP, Ethernet/IP and DeviceNet
- High standard protection class 3C2 as standard, optional class 3C3

Approvals / Marking



UL, cUL, C-Tick, EAC

Applications

Conveyors, mixers, agitators, lathes, spinning machines, machine tool, grinder, extruders, plastic injection molding machines, constant displacement pumps, woodworking machines.

Product numbering system diagram

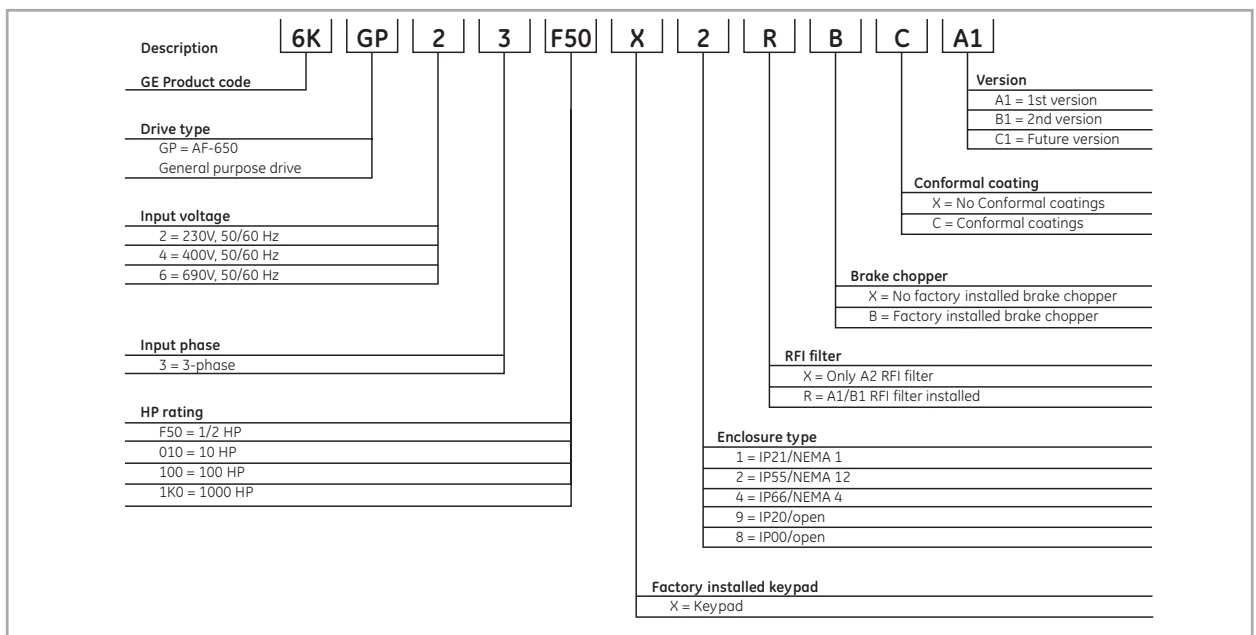

Product number for illustrative purposes only



IP00 / IP20 / IP21, with EMC filter Class A2 (C3)

230V, 3-phase, 50/60Hz input

Heavy Duty rating Nominal motor ratings			Light Duty rating Nominal motor ratings			Enclosure type ¹⁾ :	WITH braking chopper		WITHOUT braking chopper		Unit size
Power kW	Current A	Overload current during 60s (A)	Power kW	Current A	Overload current during 60s (A)		Cat. No. and Ref. No.		Cat. No. Ref. No.		
0.25	1.8	2.88	0.25	1.8	2.88	IP20	6KGP23F33X9XBXA1	6KGP23F33X9XXXXA1	404670	12	
0.37	2.4	3.84	0.37	2.4	3.84		6KGP23F50X9XBXA1	6KGP23F50X9XXXXA1	404671	12	
0.75	4.6	7.36	0.75	4.6	7.36		6KGP23001X9XBXA1	6KGP23001X9XXXXA1	404672	12	
1.5	7.5	12	1.5	7.5	12		6KGP23002X9XBXA1	6KGP23002X9XXXXA1	404673	12	
2.2	10.6	16.96	2.2	10.6	16.96		6KGP23003X9XBXA1	6KGP23003X9XXXXA1	404674	12	
3.7	16.7	26.72	3.7	16.7	26.72		6KGP23005X9XBXA1	6KGP23005X9XXXXA1	404675	13	
5.5	24.2	38.72	5.5/7.5	30.8	33.88		6KGP23007X9XBXA1	6KGP23007X9XXXXA1	404676	23	
7.5	30.8	49.28	11	46.2	50.82		6KGP23010X9XBXA1	6KGP23010X9XXXXA1	404677	23	
11	46.2	73.92	15	59.4	65.34		6KGP23015X9XBXA1	6KGP23015X9XXXXA1	404678	24	
15	59.4	89.1	18.5	74.8	82.28		6KGP23020X9XBXA1	6KGP23020X9XXXXA1	404679	24	
18.5	74.8	112.2	22	88	96.8		6KGP23025X9XBXA1	6KGP23025X9XXXXA1	404680	33	
22	88	132	30	115	126.5		6KGP23030X9XBXA1	6KGP23030X9XXXXA1	404681	33	
30	115	172.5	37	143	157.3		6KGP23040X9XBXA1	6KGP23040X9XXXXA1	404682	34	
37	143	214.5	45	170	187		6KGP23050X9XBXA1	6KGP23050X9XXXXA1	404683	34	

400V, 3-phase, 50/60Hz input

Heavy Duty rating Nominal motor ratings			Light Duty rating Nominal motor ratings			Enclosure type ¹⁾ :	WITH braking chopper		WITHOUT braking chopper		Unit size
Power kW	Current A	Overload current during 60s (A)	Power kW	Current A	Overload current during 60s (A)		Cat. No.	Ref. No.	Cat. No.	Ref. No.	
0.37	1.3	2.08	0.37	1.3	1.43	IP20	6KGP43F50X9XBXA1	403116	6KGP43F50X9XXXXA1	400412	12
0.75	2.4	3.84	0.75	2.4	2.64		6KGP43001X9XBXA1	403117	6KGP43001X9XXXXA1	400451	12
1.5	4.1	6.56	1.5	4.1	4.51		6KGP43002X9XBXA1	403118	6KGP43002X9XXXXA1	401212	12
2.2	5.6	8.96	2.2	5.6	6.16		6KGP43003X9XBXA1	403119	6KGP43003X9XXXXA1	401362	12
4	10	16	4	10	11		6KGP43005X9XBXA1	403120	6KGP43005X9XXXXA1	402735	12
5.5	13	20.8	5.5	13	14.3		6KGP43007X9XBXA1	403121	6KGP43007X9XXXXA1	402738	13
7.5	16	25.6	7.5	16	17.6		6KGP43010X9XBXA1	403122	6KGP43010X9XXXXA1	402746	13
11	24	38.4	11/15	32	35.2		6KGP43015X9XBXA1	403123	6KGP43015X9XXXXA1	402747	23
15	32	51.2	18.5	37.5	41.25		6KGP43020X9XBXA1	403124	6KGP43020X9XXXXA1	402748	23
18.5	37.5	60	22	44	48.4		6KGP43025X9XBXA1	403125	6KGP43025X9XXXXA1	402765	24
22	44	70.4	30	61	67.1		6KGP43030X9XBXA1	403126	6KGP43030X9XXXXA1	402766	24
30	61	97.6	37	73	80.3		6KGP43040X9XBXA1	403127	6KGP43040X9XXXXA1	402767	24
37	73	116.8	45	90	99		6KGP43050X9XBXA1	403128	6KGP43050X9XXXXA1	402768	33
45	90	144	55	106	116.6		6KGP43060X9XBXA1	403129	6KGP43060X9XXXXA1	402769	33
55	106	168	75	147	161.7		6KGP43075X9XBXA1	403130	6KGP43075X9XXXXA1	402857	34
75	147	235.2	90	177	194.7		6KGP43100X9XBXA1	403131	6KGP43100X9XXXXA1	402863	34
90	177	265.5	110	212	233.2		6KGP43125X9XBCB1	409619	6KGP43125X9XXCB1	409600	43h
110	212	318	132	260	286		6KGP43150X9XBCB1	409620	6KGP43150X9XXCB1	409601	43h
132	260	390	160	315	346.5		6KGP43200X9XBCB1	409621	6KGP43200X9XXCB1	409602	43h
160	315	472.5	200	395	434.5	6KGP43250X9XBCB1	409622	6KGP43250X9XXCB1	409603	44h	
200	395	592.5	250	480	528	6KGP43300X9XBCB1	409623	6KGP43300X9XXCB1	409604	44h	
250	480	720	315	588	647	6KGP43350X9XBCB1	409624	6KGP43350X9XXCB1	409605	44h	
315	600	900	355	658	723.8	6KGP43350X8XBCA1	403138	6KGP43350X8XXCA1	402870	52	
355	658	987	400	745	819.5	6KGP43500X8XBCA1	403139	6KGP43500X8XXCA1	402871	52	
400	745	1117.5	450	800	880	6KGP43550X8XBCA1	403140	6KGP43550X8XXCA1	402872	52	
450	800	1200	500	880	968	6KGP43600X1XBCA1	403141	6KGP43600X1XXCA1	402873	61	
500	880	1320	560	990	1089	6KGP43650X1XBCA1	403142	6KGP43650X1XXCA1	402874	61	
560	990	1485	630	1120	1232	6KGP43750X1XBCA1	403143	6KGP43750X1XXCA1	402875	61	
630	1120	1680	710	1260	1386	6KGP43900X1XBCA1	403144	6KGP43900X1XXCA1	402876	61	
710	1260	1890	800	1460	1606	6KGP431K0X1XBCA1	403145	6KGP431K0X1XXCA1	402877	62	
800	1460	2190	1000	1720	1870	6KGP431K2X1XBCA1	403146	6KGP431K2X1XXCA1	402878	62	

690V, 3-phase, 50/60Hz input

Heavy Duty rating Nominal motor ratings			Light Duty rating Nominal motor ratings			Enclosure type:	WITH braking chopper		WITHOUT braking chopper		Unit size
Power kW	Current A	Overload current during 60s (A)	Power kW	Current A	Overload current during 60s (A)		Cat. No. and Ref. No.		Cat. No. and Ref. No.		
11	13	20.8	15	18	19.8	IP21 conformal coated	6KGP63015X1XBCA1		6KGP63015X1XXCA1	22	
15	18	28.8	18.5	22	24.2		6KGP63020X1XBCA1		6KGP63020X1XXCA1	22	
18.5	22	35.2	22	27	29.7		6KGP63025X1XBCA1		6KGP63025X1XXCA1	22	
22	27	43.2	30	34	37.4		6KGP63030X1XBCA1		6KGP63030X1XXCA1	22	
30	34	51	37	41	45.1		6KGP63040X1XBCA1		6KGP63040X1XXCA1	32	
37	41	61.5	45	52	57.2		6KGP63050X1XBCA1		6KGP63050X1XXCA1	32	
45	52	78	55	62	68.2		6KGP63060X1XBCA1		6KGP63060X1XXCA1	32	
55	62	93	75	83	91.3		6KGP63075X1XBCA1		6KGP63075X1XXCA1	32	
75	83	124.5	90	108	118.8		6KGP63100X1XBCA1		6KGP63100X1XXCA1	32	
90	108	162	110	131	144.1		6KGP63125X9XBCB1		6KGP63125X9XXCB1	45h/43h	
110	131	196.5	132	155	170.5		6KGP63150X9XBCB1		6KGP63150X9XXCB1	45h/43h	
132	155	232.5	160	192	211.2		6KGP63200X9XBCB1		6KGP63200X9XXCB1	45h/43h	
160	192	288	200	242	266.2		6KGP63250X9XBCB1		6KGP63250X9XXCB1	47h/44h	
200	242	363	250	290	319		6KGP63300X9XBCB1		6KGP63300X9XXCB1	47h/44h	
250	290	435	315	344	378.4		6KGP63350X9XBCB1		6KGP63350X9XXCB1	47h/44h	
315	344	516	355	380	418		6KGP63450X9XBCB1		6KGP63450X9XXCB1	47h/44h	
355	380	570	400	410	451		6KGP63550X8XBCA1		6KGP63550X8XXCA1	52	
400	410	615	500	500	550		6KGP63600X8XBCA1		6KGP63600X8XXCA1	52	
500	500	750	560	570	627		6KGP63650X8XBCA1		6KGP63650X8XXCA1	52	
560	570	855	630	630	693	6KGP63750X8XBCA1		6KGP63750X8XXCA1	52		
630	630	945	710	730	803	6KGP63900X1XBCA1		6KGP63900X1XXCA1	61		
710	730	1095	800	850	935	6KGP631K0X1XBCA1		6KGP631K0X1XXCA1	61		
800	850	1275	900	945	1039.5	6KGP631K1X1XBCA1		6KGP631K1X1XXCA1	61		
900	945	1417.5	1000	1060	1166	6KGP631K2X1XBCA1		6KGP631K2X1XXCA1	63		
1000	1060	1590	1200	1260	1386	6KGP631K3X1XBCA1		6KGP631K3X1XXCA1	63		
1200	1260	1890	1400	1415	1556.5	6KGP631K6X1XBCA1		6KGP631K6X1XXCA1	63		

(1) IP21 kits are available as field installed options for all 230V drives from 0.25 to 37kW for all 400V drives from 0.37 to 75kW. See Page G.41.



AF-650 GP

IP00 / IP20 / IP21, with EMC filter Class A1/B1 (C1/C2)

230V, 3-phase, 50/60Hz input

Heavy Duty rating Nominal motor ratings			Light Duty rating Nominal motor ratings			Enclosure type ⁽¹⁾ :	WITH braking chopper		WITHOUT braking chopper		Unit size
Power kW	Current A	Overload current during 60s (A)	Power kW	Current A	Overload current during 60s (A)		Cat. No. and Ref. No.		Cat. No. and Ref. No.		
0.25	1.8	2.88	0.25	1.8	2.88	IP20	6KGP23F33X9RBXA1	6KGP23F33X9RXXA1	12	12	
0.37	2.4	3.84	0.37	2.4	3.84		6KGP23F50X9RBXA1	6KGP23F50X9RXXA1	12	12	
0.75	4.6	7.36	0.75	4.6	7.36		6KGP23001X9RBXA1	6KGP23001X9RXXA1	12	12	
1.5	7.5	12	1.5	7.5	12		6KGP23002X9RBXA1	6KGP23002X9RXXA1	12	12	
2.2	10.6	16.96	2.2	10.6	16.96		6KGP23003X9RBXA1	6KGP23003X9RXXA1	12	12	
3.7	16.7	26.72	3.7	16.7	26.72		6KGP23005X9RBXA1	6KGP23005X9RXXA1	13	13	
5.5	24.2	38.72	5.5/7.5	30.8	33.88		6KGP23007X9RBXA1	6KGP23007X9RXXA1	23	23	
7.5	30.8	49.28	11	46.2	50.82		6KGP23010X9RBXA1	6KGP23010X9RXXA1	23	23	
11	46.2	73.92	15	59.4	65.34		6KGP23015X9RBXA1	6KGP23015X9RXXA1	24	24	
15	59.4	89.1	18.5	74.8	82.28		6KGP23020X9RBXA1	6KGP23020X9RXXA1	24	24	
18.5	74.8	112.2	22	88	96.8		6KGP23025X9RBXA1	6KGP23025X9RXXA1	33	33	
22	88	132	30	115	126.5		6KGP23030X9RBXA1	6KGP23030X9RXXA1	33	33	
30	115	172.5	37	143	157.3		6KGP23040X9RBXA1	6KGP23040X9RXXA1	34	34	
37	143	214.5	45	170	187		6KGP23050X9RBXA1	6KGP23050X9RXXA1	34	34	

400V, 3-phase, 50/60Hz input

Heavy Duty rating Nominal motor ratings			Light Duty rating Nominal motor ratings			Enclosure type ⁽¹⁾ :	WITH braking chopper		WITHOUT braking chopper		Unit size
Power kW	Current A	Overload current during 60s (A)	Power kW	Current A	Overload current during 60s (A)		Cat. No.	Ref. No.	Cat. No.	Ref. No.	
0.37	1.3	2.08	0.37	1.3	1.43	IP20	6KGP43F50X9RBXA1	403203	6KGP43F50X9RXXA1	402935	12
0.75	2.4	3.84	0.75	2.4	2.64		6KGP43001X9RBXA1	403204	6KGP43001X9RXXA1	402936	12
1.5	4.1	6.56	1.5	4.1	4.51		6KGP43002X9RBXA1	403205	6KGP43002X9RXXA1	402937	12
2.2	5.6	8.96	2.2	5.6	6.16		6KGP43003X9RBXA1	403206	6KGP43003X9RXXA1	402938	12
4	10	16	4	10	11		6KGP43005X9RBXA1	403207	6KGP43005X9RXXA1	402939	12
5.5	13	20.8	5.5	13	14.3		6KGP43007X9RBXA1	403208	6KGP43007X9RXXA1	402940	13
7.5	16	25.6	7.5	16	17.6		6KGP43010X9RBXA1	403209	6KGP43010X9RXXA1	402941	13
11	24	38.4	11/15	32	35.2		6KGP43015X9RBXA1	403210	6KGP43015X9RXXA1	402942	23
15	32	51.2	18.5	37.5	41.25		6KGP43020X9RBXA1	403211	6KGP43020X9RXXA1	402943	23
18.5	37.5	60	22	44	48.4		6KGP43025X9RBXA1	403212	6KGP43025X9RXXA1	402944	24
22	44	70.4	30	61	67.1		6KGP43030X9RBXA1	403213	6KGP43030X9RXXA1	402945	24
30	61	97.6	37	73	80.3		6KGP43040X9RBXA1	403214	6KGP43040X9RXXA1	402946	24
37	73	116.8	45	90	99		6KGP43050X9RBXA1	403215	6KGP43050X9RXXA1	402947	33
45	90	144	55	106	116.6		6KGP43060X9RBXA1	403216	6KGP43060X9RXXA1	402948	33
55	106	168	75	147	161.7		6KGP43075X9RBXA1	403217	6KGP43075X9RXXA1	402949	34
75	147	235.2	90	177	194.7		6KGP43100X9RBXA1	403218	6KGP43100X9RXXA1	402950	34
90	177	265.5	110	212	233.2		6KGP43125X9RBCB1	409634	6KGP43125X9RXC1	409607	43h
110	212	318	132	260	286		6KGP43150X9RBCB1	409635	6KGP43150X9RXC1	409608	43h
132	260	390	160	315	346.5		6KGP43200X9RBCB1	409636	6KGP43200X9RXC1	409609	43h
160	315	472.5	200	395	434.5	6KGP43250X9RBCB1	409637	6KGP43250X9RXC1	409610	44h	
200	395	592.5	250	480	528	6KGP43300X9RBCB1	409638	6KGP43300X9RXC1	409611	44h	
250	480	720	315	588	647	6KGP43350X9RBCB1	409639	6KGP43350X9RXC1	409612	44h	
315	600	900	355	658	723.8	6KGP43400X9RBCA1	403225	6KGP43400X9RXC1	402957	52	
355	658	987	400	745	819.5	6KGP43500X9RBCA1	403226	6KGP43500X9RXC1	402958	52	
400	745	1117.5	450	800	880	6KGP43550X9RBCA1	403227	6KGP43550X9RXC1	402959	52	
450	800	1200	500	880	968	6KGP43600X1RBCA1	403228	6KGP43600X1RXC1	402960	63	
500	880	1320	560	990	1089	6KGP43650X1RBCA1	403229	6KGP43650X1RXC1	402961	63	
560	990	1485	630	1120	1232	6KGP43750X1RBCA1	403230	6KGP43750X1RXC1	402962	63	
630	1120	1680	710	1260	1386	6KGP43900X1RBCA1	403231	6KGP43900X1RXC1	402963	63	
710	1260	1890	800	1460	1606	6KGP431K0X1RBCA1	403232	6KGP431K0X1RXC1	402964	64	
800	1460	2190	1000	1720	1870	6KGP431K2X1RBCA1	403233	6KGP431K2X1RXC1	402965	64	

690V, 3-phase, 50/60Hz input

Heavy Duty rating Nominal motor ratings			Light Duty rating Nominal motor ratings			Enclosure type:	WITH braking chopper		WITHOUT braking chopper		Unit size
Power kW	Current A	Overload current during 60s (A)	Power kW	Current A	Overload current during 60s (A)		Cat. No. and Ref. No.		Cat. No. and Ref. No.		
11	13	20.8	15	18	19.8	IP21 conformal coated	6KGP63015X1RBCA1		6KGP63015X1RXC1		22
15	18	28.8	18.5	22	24.2		6KGP63020X1RBCA1		6KGP63020X1RXC1		22
18.5	22	35.2	22	27	29.7		6KGP63025X1RBCA1		6KGP63025X1RXC1		22
22	27	43.2	30	34	37.4		6KGP63030X1RBCA1		6KGP63030X1RXC1		22
30	34	51	37	41	45.1		6KGP63040X1RBCA1		6KGP63040X1RXC1		32
37	41	61.5	45	52	57.2		6KGP63050X1RBCA1		6KGP63050X1RXC1		32
45	52	78	55	62	68.2		6KGP63060X1RBCA1		6KGP63060X1RXC1		32
55	62	93	75	83	91.3		6KGP63075X1RBCA1		6KGP63075X1RXC1		32
75	83	124.5	90	108	118.8		6KGP63100X1RBCA1		6KGP63100X1RXC1		32
90	108	162	110	131	144.1		6KGP63125X9RBCB1		6KGP63125X9RXC1		45h/43h
110	131	196.5	132	155	170.5		6KGP63150X9RBCB1		6KGP63150X9RXC1		45h/43h
132	155	232.5	160	192	211.2		6KGP63200X9RBCB1		6KGP63200X9RXC1		45h/43h
160	192	288	200	242	266.2		6KGP63250X9RBCB1		6KGP63250X9RXC1		47h/44h
200	242	363	250	290	319		6KGP63300X9RBCB1		6KGP63300X9RXC1		47h/44h
250	290	435	315	344	378.4		6KGP63350X9RBCB1		6KGP63350X9RXC1		47h/44h
315	344	516	355	380	418		6KGP63400X9RBCB1		6KGP63400X9RXC1		47h/44h
355	380	570	400	410	451		6KGP63550X8RBCA1		6KGP63550X8RXC1		52
400	410	615	500	500	550		6KGP63600X8RBCA1		6KGP63600X8RXC1		52
500	500	750	560	570	627		6KGP63650X8RBCA1		6KGP63650X8RXC1		52
560	570	855	630	630	693	6KGP63750X8RBCA1		6KGP63750X8RXC1		52	
630	630	945	710	730	803	6KGP63900X1RBCA1		6KGP63900X1RXC1		62	
710	730	1095	800	850	935	6KGP631K0X1RBCA1		6KGP631K0X1RXC1		62	
800	850	1275	900	945	1039.5	6KGP631K1X1RBCA1		6KGP631K1X1RXC1		62	
900	945	1417.5	1000	1060	1166	6KGP631K2X1RBCA1		6KGP631K2X1RXC1		64	
1000	1060	1590	1200	1260	1386	6KGP631K3X1RBCA1		6KGP631K3X1RXC1		64	
1200	1260	1890	1400	1415	1556.5	6KGP631K6X1RBCA1		6KGP631K6X1RXC1		64	

(1) IP21 kits are available as field installed options for all 230V drives from 0.25 to 37kW for all 400V drives from 0.37 to 75kW. See Page G.41.

AF-6 drives

Intro

A

B

C

D

E

F

G

H

I

X



IP54 / IP55, with EMC filter Class A2 (C3)

230V, 3-phase, 50/60Hz input

Heavy Duty rating Nominal motor ratings			Light Duty rating Nominal motor ratings			Enclosure type:	WITH braking chopper		WITHOUT braking chopper		Unit size
Power kW	Current A	Overload current during 60s (A)	Power kW	Current A	Overload current during 60s (A)		Cat. No.	Ref. No.	Cat. No.	Ref. No.	
0.25	1.8	2.88	0.25	1.8	2.88	IP55	6KGP23F33X2XBXA1		6KGP23F33X2XXXA1	404710	15
0.37	2.4	3.84	0.37	2.4	3.84		6KGP23F50X2XBXA1		6KGP23F50X2XXXA1	404711	15
0.75	4.6	7.36	0.75	4.6	7.36		6KGP23001X2XBXA1		6KGP23001X2XXXA1	404712	15
1.5	7.5	12	1.5	7.5	12		6KGP23002X2XBXA1		6KGP23002X2XXXA1	404713	15
2.2	10.6	16.96	2.2	10.6	16.96		6KGP23003X2XBXA1		6KGP23003X2XXXA1	404714	15
3.7	16.7	26.72	3.7	16.7	26.72		6KGP23005X2XBXA1		6KGP23005X2XXXA1	404715	15
5.5	24.2	38.72	5.5/7.5	30.8	33.88		6KGP23007X2XBXA1		6KGP23007X2XXXA1	404716	21
7.5	30.8	49.28	11	46.2	50.82		6KGP23010X2XBXA1		6KGP23010X2XXXA1	404717	21
11	46.2	73.92	15	59.4	65.34		6KGP23015X2XBXA1		6KGP23015X2XXXA1	404718	22
15	59.4	89.1	18.5	74.8	82.28		6KGP23020X2XBXA1		6KGP23020X2XXXA1	404719	31
18.5	74.8	112.2	22	88	96.8		6KGP23025X2XBXA1		6KGP23025X2XXXA1	404720	31
22	88	132	30	115	126.5		6KGP23030X2XBXA1		6KGP23030X2XXXA1	404721	31
30	115	172.5	37	143	157.3		6KGP23040X2XBXA1		6KGP23040X2XXXA1	404722	32
37	143	214.5	45	170	187		6KGP23050X2XBXA1		6KGP23050X2XXXA1	404723	32

400V, 3-phase, 50/60Hz input

Heavy Duty rating Nominal motor ratings			Light Duty rating Nominal motor ratings			Enclosure type:	WITH braking chopper		WITHOUT braking chopper		Unit size
Power kW	Current A	Overload current during 60s (A)	Power kW	Current A	Overload current during 60s (A)		Cat. No.	Ref. No.	Cat. No.	Ref. No.	
0.37	1.3	2.08	0.37	1.3	1.43	IP55	6KGP43F50X2XBXA1	403156	6KGP43F50X2XXXA1	402888	15
0.75	2.4	3.84	0.75	2.4	2.64		6KGP43001X2XBXA1	403157	6KGP43001X2XXXA1	402889	15
1.5	4.1	6.56	1.5	4.1	4.51		6KGP43002X2XBXA1	403158	6KGP43002X2XXXA1	402890	15
2.2	5.6	8.96	2.2	5.6	6.16		6KGP43003X2XBXA1	403159	6KGP43003X2XXXA1	402891	15
4	10	16	4	10	11		6KGP43005X2XBXA1	403160	6KGP43005X2XXXA1	402892	15
5.5	13	20.8	5.5	13	14.3		6KGP43007X2XBXA1	403161	6KGP43007X2XXXA1	402893	15
7.5	16	25.6	7.5	16	17.6		6KGP43010X2XBXA1	403162	6KGP43010X2XXXA1	402894	15
11	24	38.4	11/15	32	35.2		6KGP43015X2XBXA1	403163	6KGP43015X2XXXA1	402895	21
15	32	51.2	18.5	37.5	41.25		6KGP43020X2XBXA1	403164	6KGP43020X2XXXA1	402896	21
18.5	37.5	60	22	44	48.4		6KGP43025X2XBXA1	403165	6KGP43025X2XXXA1	402897	22
22	44	70.4	30	61	67.1		6KGP43030X2XBXA1	403166	6KGP43030X2XXXA1	402898	22
30	61	97.6	37	73	80.3		6KGP43040X2XBXA1	403167	6KGP43040X2XXXA1	402899	22
37	73	116.8	45	90	99		6KGP43050X2XBXA1	403168	6KGP43050X2XXXA1	402900	31
45	90	144	55	106	116.6		6KGP43060X2XBXA1	403169	6KGP43060X2XXXA1	402901	31
55	106	168	75	147	161.7		6KGP43075X2XBXA1	403170	6KGP43075X2XXXA1	402902	32
75	147	235.2	90	177	194.7		6KGP43100X2XBXA1	403171	6KGP43100X2XXXA1	402903	32
90	177	265.5	110	212	233.2		6KGP43125X2XBCB1	409626	6KGP43125X2XXCB1	409646	41h
110	212	318	132	260	286	6KGP43150X2XBCB1	409628	6KGP43150X2XXCB1	409647	41h	
132	260	390	160	315	346.5	6KGP43200X2XBCB1	409630	6KGP43200X2XXCB1	409648	41h	
160	315	472.5	200	395	434.5	6KGP43250X2XBCB1	409631	6KGP43250X2XXCB1	409649	42h	
200	395	592.5	250	480	528	6KGP43300X2XBCB1	409632	6KGP43300X2XXCB1	409650	42h	
250	480	720	315	600	660	6KGP43350X2XBCB1	409633	6KGP43350X2XXCB1	409606	42h	
315	600	900	355	658	723.8	6KGP43450X2XBCA1	403178	6KGP43450X2XXCA1	402910	52	
355	658	987	400	745	819.5	6KGP43500X2XBCA1	403179	6KGP43500X2XXCA1	402911	52	
400	745	1117.5	450	800	880	6KGP43550X2XBCA1	403180	6KGP43550X2XXCA1	402912	52	
450	800	1200	500	880	968	6KGP43600X2XBCA1	403181	6KGP43600X2XXCA1	402913	61	
500	880	1320	560	990	1089	6KGP43650X2XBCA1	403182	6KGP43650X2XXCA1	402914	61	
560	990	1485	630	1120	1232	6KGP43750X2XBCA1	403183	6KGP43750X2XXCA1	402915	61	
630	1120	1680	710	1260	1386	6KGP43900X2XBCA1	403184	6KGP43900X2XXCA1	402916	61	
710	1260	1890	800	1460	1606	6KGP431K0X2XBCA1	403185	6KGP431K0X2XXCA1	402917	62	
800	1460	2190	1000	1720	1870	6KGP431K2X2XBCA1	403186	6KGP431K2X2XXCA1	402918	62	

690V, 3-phase, 50/60Hz input

Heavy Duty rating Nominal motor ratings			Light Duty rating Nominal motor ratings			Enclosure type:	WITH braking chopper		WITHOUT braking chopper		Unit size
Power kW	Current A	Overload current during 60s (A)	Power kW	Current A	Overload current during 60s (A)		Cat. No. and Ref. No.	Cat. No. and Ref. No.			
11	13	20.8	15	18	19.8	IP55 conformal coated	6KGP63015X2XBCA1		6KGP63015X2XXCA1	22	
15	18	28.8	18.5	22	24.2		6KGP63020X2XBCA1		6KGP63020X2XXCA1	22	
18.5	22	35.2	22	27	29.7		6KGP63025X2XBCA1		6KGP63025X2XXCA1	22	
22	27	43.2	30	34	37.4		6KGP63030X2XBCA1		6KGP63030X2XXCA1	22	
30	34	51	37	41	45.1		6KGP63040X2XBCA1		6KGP63040X2XXCA1	32	
37	41	61.5	45	52	57.2		6KGP63050X2XBCA1		6KGP63050X2XXCA1	32	
45	52	78	55	62	68.2		6KGP63060X2XBCA1		6KGP63060X2XXCA1	32	
55	62	93	75	83	91.3		6KGP63075X2XBCA1		6KGP63075X2XXCA1	32	
75	83	124.5	90	108	118.8		6KGP63100X2XBCA1		6KGP63100X2XXCA1	32	
90	108	162	110	131	144.1		6KGP63125X2XBCB1		6KGP63125X2XXCB1	45h/41h	
110	131	196.5	132	155	170.5		6KGP63150X2XBCB1		6KGP63150X2XXCB1	45h/41h	
132	155	232.5	160	192	211.2		6KGP63200X2XBCB1		6KGP63200X2XXCB1	45h/41h	
160	192	288	200	242	266.2		6KGP63250X2XBCB1		6KGP63250X2XXCB1	47h/42h	
200	242	363	250	290	319		6KGP63300X2XBCB1		6KGP63300X2XXCB1	47h/42h	
250	290	435	315	344	378.4		6KGP63350X2XBCB1		6KGP63350X2XXCB1	47h/42h	
315	344	516	355	380	418		6KGP63450X2XBCB1		6KGP63450X2XXCB1	47h/42h	
355	380	570	400	410	451		6KGP63550X2XBCA1		6KGP63550X2XXCA1	51	
400	410	615	500	500	550	6KGP63600X2XBCA1		6KGP63600X2XXCA1	51		
500	500	750	560	570	627	6KGP63650X2XBCA1		6KGP63650X2XXCA1	51		
560	570	855	630	630	693	6KGP63750X2XBCA1		6KGP63750X2XXCA1	51		
630	630	945	710	730	803	6KGP63900X2XBCA1		6KGP63900X2XXCA1	61		
710	730	1095	800	850	935	6KGP631K0X2XBCA1		6KGP631K0X2XXCA1	61		
800	850	1275	900	945	1039.5	6KGP631K1X2XBCA1		6KGP631K1X2XXCA1	61		
900	945	1417.5	1000	1060	1166	6KGP631K2X2XBCA1		6KGP631K2X2XXCA1	63		
1000	1060	1590	1200	1260	1386	6KGP631K3X2XBCA1		6KGP631K3X2XXCA1	63		
1200	1260	1890	1400	1415	1556.5	6KGP631K6X2XBCA1		6KGP631K6X2XXCA1	63		



AF-650 GP

IP54 / IP55, with EMC filter A1/B1 (C1/C2)

230V, 3-phase, 50/60Hz input

Heavy Duty rating Nominal motor ratings			Light Duty rating Nominal motor ratings			Enclosure type:	WITH braking chopper		WITHOUT braking chopper		Unit size
Power kW	Current A	Overload current during 60s (A)	Power kW	Current A	Overload current during 60s (A)		Cat. No. and Ref. No.		Cat. No. and Ref. No.		
0.25	1.8	2.88	0.25	1.8	2.88	IP55	6KGP23F33X2R8XA1		6KGP23F33X2R8XA1		15
0.37	2.4	3.84	0.37	2.4	3.84		6KGP23F50X2R8XA1		6KGP23F50X2R8XA1		15
0.75	4.6	7.36	0.75	4.6	7.36		6KGP23001X2R8XA1		6KGP23001X2R8XA1		15
1.5	7.5	12	1.5	7.5	12		6KGP23002X2R8XA1		6KGP23002X2R8XA1		15
2.2	10.6	16.96	2.2	10.6	16.96		6KGP23003X2R8XA1		6KGP23003X2R8XA1		15
3.7	16.7	26.72	3.7	16.7	26.72		6KGP23005X2R8XA1		6KGP23005X2R8XA1		15
5.5	24.2	38.72	5.5/7.5	30.8	33.88		6KGP23007X2R8XA1		6KGP23007X2R8XA1		21
7.5	30.8	49.28	11	46.2	50.82		6KGP23010X2R8XA1		6KGP23010X2R8XA1		21
11	46.2	73.92	15	59.4	65.34		6KGP23015X2R8XA1		6KGP23015X2R8XA1		22
15	59.4	89.1	18.5	74.8	82.28		6KGP23020X2R8XA1		6KGP23020X2R8XA1		31
18.5	74.8	112.2	22	88	96.8		6KGP23025X2R8XA1		6KGP23025X2R8XA1		31
22	88	132	30	115	126.5		6KGP23030X2R8XA1		6KGP23030X2R8XA1		31
30	115	172.5	37	143	157.3		6KGP23040X2R8XA1		6KGP23040X2R8XA1		32
37	143	214.5	45	170	187		6KGP23050X2R8XA1		6KGP23050X2R8XA1		32

400V, 3-phase, 50/60Hz input

Heavy Duty rating Nominal motor ratings			Light Duty rating Nominal motor ratings			Enclosure type:	WITH braking chopper		WITHOUT braking chopper		Unit size
Power kW	Current A	Overload current during 60s (A)	Power kW	Current A	Overload current during 60s (A)		Cat. No.	Ref. No.	Cat. No.	Ref. No.	
0.37	1.3	2.08	0.37	1.3	1.43	IP55	6KGP43F50X2R8XA1	403243	6KGP43F50X2R8XA1	402975	15
0.75	2.4	3.84	0.75	2.4	2.64		6KGP43001X2R8XA1	403244	6KGP43001X2R8XA1	402976	15
1.5	4.1	6.56	1.5	4.1	4.51		6KGP43002X2R8XA1	403245	6KGP43002X2R8XA1	402977	15
2.2	5.6	8.96	2.2	5.6	6.16		6KGP43003X2R8XA1	403246	6KGP43003X2R8XA1	402978	15
4	10	16	4	10	11		6KGP43005X2R8XA1	403247	6KGP43005X2R8XA1	402979	15
5.5	13	20.8	5.5	13	14.3		6KGP43007X2R8XA1	403248	6KGP43007X2R8XA1	402980	15
7.5	16	25.6	7.5	16	17.6		6KGP43010X2R8XA1	403249	6KGP43010X2R8XA1	402981	15
11	24	38.4	11/15	32	35.2		6KGP43015X2R8XA1	403250	6KGP43015X2R8XA1	402982	21
15	32	51.2	18.5	37.5	41.25		6KGP43020X2R8XA1	403251	6KGP43020X2R8XA1	402983	21
18.5	37.5	60	22	44	48.4		6KGP43025X2R8XA1	403252	6KGP43025X2R8XA1	402984	22
22	44	70.4	30	61	67.1		6KGP43030X2R8XA1	403253	6KGP43030X2R8XA1	402985	22
30	61	97.6	37	73	80.3		6KGP43040X2R8XA1	403254	6KGP43040X2R8XA1	402986	31
37	73	116.8	45	90	99		6KGP43050X2R8XA1	403255	6KGP43050X2R8XA1	402987	31
45	90	144	55	106	116.6		6KGP43060X2R8XA1	403256	6KGP43060X2R8XA1	402988	31
55	106	168	75	147	161.7		6KGP43075X2R8XA1	403257	6KGP43075X2R8XA1	402989	32
75	147	235.2	90	177	194.7		6KGP43100X2R8XA1	403258	6KGP43100X2R8XA1	402990	32
90	177	265.5	110	212	233.2		6KGP43125X2R8XA1	409640	6KGP43125X2R8XA1	409613	45h
110	212	318	132	260	286		6KGP43150X2R8XA1	409641	6KGP43150X2R8XA1	409614	45h
132	260	390	160	315	346.5		6KGP43200X2R8XA1	409642	6KGP43200X2R8XA1	409615	45h
160	315	472.5	200	395	434.5	6KGP43250X2R8XA1	409643	6KGP43250X2R8XA1	409616	47h	
200	395	592.5	250	480	528	6KGP43300X2R8XA1	409644	6KGP43300X2R8XA1	409617	47h	
250	480	720	315	588	647	6KGP43350X2R8XA1	409645	6KGP43350X2R8XA1	409618	47h	
315	600	900	355	658	723.8	6KGP43400X2R8XA1	403265	6KGP43400X2R8XA1	402997	52	
355	658	987	400	745	819.5	6KGP43500X2R8XA1	403266	6KGP43500X2R8XA1	402998	52	
400	745	1117.5	450	800	880	6KGP43550X2R8XA1	403267	6KGP43550X2R8XA1	402999	52	
450	800	1200	500	880	968	6KGP43600X2R8XA1	403268	6KGP43600X2R8XA1	403094	63	
500	880	1320	560	990	1089	6KGP43650X2R8XA1	403269	6KGP43650X2R8XA1	403095	63	
560	990	1485	630	1120	1232	6KGP43750X2R8XA1	403270	6KGP43750X2R8XA1	403096	63	
630	1120	1680	710	1260	1386	6KGP43900X2R8XA1	403271	6KGP43900X2R8XA1	403097	63	
710	1260	1890	800	1460	1606	6KGP431K0X2R8XA1	403272	6KGP431K0X2R8XA1	403098	64	
800	1460	2190	1000	1720	1870	6KGP431K2X2R8XA1	403273	6KGP431K2X2R8XA1	403099	64	

690V, 3-phase, 50/60Hz input

Heavy Duty rating Nominal motor ratings			Light Duty rating Nominal motor ratings			Enclosure type:	WITH braking chopper		WITHOUT braking chopper		Unit size
Power kW	Current A	Overload current during 60s (A)	Power kW	Current A	Overload current during 60s (A)		Cat. No. and Ref. No.		Cat. No. and Ref. No.		
11	13	20.8	15	18	19.8	IP55 conformal coated	6KGP63015X2R8CA1		6KGP63015X2R8CA1		22
15	18	28.8	18.5	22	24.2		6KGP63020X2R8CA1		6KGP63020X2R8CA1		22
18.5	22	35.2	22	27	29.7		6KGP63025X2R8CA1		6KGP63025X2R8CA1		22
22	27	43.2	30	34	37.4		6KGP63030X2R8CA1		6KGP63030X2R8CA1		22
30	34	51	37	41	45.1		6KGP63040X2R8CA1		6KGP63040X2R8CA1		32
37	41	61.5	45	52	57.2		6KGP63050X2R8CA1		6KGP63050X2R8CA1		32
45	52	78	55	62	68.2		6KGP63060X2R8CA1		6KGP63060X2R8CA1		32
55	62	93	75	83	91.3		6KGP63075X2R8CA1		6KGP63075X2R8CA1		32
75	83	124.5	90	108	118.8		6KGP63100X2R8CA1		6KGP63100X2R8CA1		32
90	108	162	110	131	144.1		6KGP63125X2R8CA1		6KGP63125X2R8CA1		45h/41h
110	131	196.5	132	155	170.5		6KGP63150X2R8CA1		6KGP63150X2R8CA1		45h/41h
132	155	232.5	160	192	211.2		6KGP63200X2R8CA1		6KGP63200X2R8CA1		45h/41h
160	192	288	200	242	266.2		6KGP63250X2R8CA1		6KGP63250X2R8CA1		47h/42h
200	242	363	250	290	319		6KGP63300X2R8CA1		6KGP63300X2R8CA1		47h/42h
250	290	435	315	344	378.4		6KGP63350X2R8CA1		6KGP63350X2R8CA1		47h/42h
315	344	516	355	380	418		6KGP63450X2R8CA1		6KGP63450X2R8CA1		47h/42h
355	380	570	400	410	451		6KGP63550X2R8CA1		6KGP63550X2R8CA1		51
400	410	615	500	500	550		6KGP63600X2R8CA1		6KGP63600X2R8CA1		51
500	500	750	560	570	627		6KGP63650X2R8CA1		6KGP63650X2R8CA1		51
560	570	855	630	630	693	6KGP63750X2R8CA1		6KGP63750X2R8CA1		51	
630	630	945	710	730	803	6KGP63900X2R8CA1		6KGP63900X2R8CA1		62	
710	730	1095	800	850	935	6KGP631K0X2R8CA1		6KGP631K0X2R8CA1		62	
800	850	1275	900	945	1039.5	6KGP631K1X2R8CA1		6KGP631K1X2R8CA1		62	
900	945	1417.5	1000	1060	1166	6KGP631K2X2R8CA1		6KGP631K2X2R8CA1		64	
1000	1060	1590	1200	1260	1386	6KGP631K3X2R8CA1		6KGP631K3X2R8CA1		64	
1200	1260	1890	1400	1415	1556.5	6KGP631K6X2R8CA1		6KGP631K6X2R8CA1		64	

AF-6 drives

Intro

A

B

C

D

E

F

G

H

I

X



IP66, with EMC filter Class A2 (C3)

230V, 3-phase, 50/60Hz input

Heavy Duty rating Nominal motor ratings			Light Duty rating Nominal motor ratings			WITH braking chopper		WITHOUT braking chopper		Unit size
Power kW	Current A	Overload current during 60s (A)	Power kW	Current A	Overload current during 60s (A)	Cat. No. and Ref. No.		Cat. No.	Ref. No.	
0.25	1.8	2.88	0.25	1.8	2.88	6KGP23F33X4XBXA1		6KGP23F33X4XXXA1	404724	15
0.37	2.4	3.84	0.37	2.4	3.84	6KGP23F50X4XBXA1		6KGP23F50X4XXXA1	404725	15
0.75	4.6	7.36	0.75	4.6	7.36	6KGP23001X4XBXA1		6KGP23001X4XXXA1	404726	15
1.5	7.5	12	1.5	7.5	12	6KGP23002X4XBXA1		6KGP23002X4XXXA1	404727	15
2.2	10.6	16.96	2.2	10.6	16.96	6KGP23003X4XBXA1		6KGP23003X4XXXA1	404728	15
3.7	16.7	26.72	3.7	16.7	26.72	6KGP23005X4XBXA1		6KGP23005X4XXXA1	404729	15
5.5	24.2	38.72	5.5/7.5	30.8	33.88	6KGP23007X4XBXA1		6KGP23007X4XXXA1	404730	21
7.5	30.8	49.28	11	46.2	50.82	6KGP23010X4XBXA1		6KGP23010X4XXXA1	404731	21
11	46.2	73.92	15	59.4	65.34	6KGP23015X4XBXA1		6KGP23015X4XXXA1	404732	22
15	59.4	89.1	18.5	74.8	82.28	6KGP23020X4XBXA1		6KGP23020X4XXXA1	404733	31
18.5	74.8	112.2	22	88	96.8	6KGP23025X4XBXA1		6KGP23025X4XXXA1	404734	31
22	88	132	30	115	126.5	6KGP23030X4XBXA1		6KGP23030X4XXXA1	404735	31
30	115	172.5	37	143	157.3	6KGP23040X4XBXA1		6KGP23040X4XXXA1	404736	32
37	143	214.5	45	170	187	6KGP23050X4XBXA1		6KGP23050X4XXXA1	404737	32

400V, 3-phase, 50/60Hz input

Heavy Duty rating Nominal motor ratings			Light Duty rating Nominal motor ratings			WITH braking chopper		WITHOUT braking chopper		Unit size
Power kW	Current A	Overload current during 60s (A)	Power kW	Current A	Overload current during 60s (A)	Cat. No.	Ref. No.	Cat. No.	Ref. No.	
0.37	1.3	2.08	0.37	1.3	1.43	6KGP43F50X4XBXA1	403187	6KGP43F50X4XXXA1	402919	15
0.75	2.4	3.84	0.75	2.4	2.64	6KGP43001X4XBXA1	403188	6KGP43001X4XXXA1	402920	15
1.5	4.1	6.56	1.5	4.1	4.51	6KGP43002X4XBXA1	403189	6KGP43002X4XXXA1	402921	15
2.2	5.6	8.96	2.2	5.6	6.16	6KGP43003X4XBXA1	403190	6KGP43003X4XXXA1	402922	15
4	10	16	4	10	11	6KGP43005X4XBXA1	403191	6KGP43005X4XXXA1	402923	15
5.5	13	20.8	5.5	13	14.3	6KGP43007X4XBXA1	403192	6KGP43007X4XXXA1	402924	15
7.5	16	25.6	7.5	16	17.6	6KGP43010X4XBXA1	403193	6KGP43010X4XXXA1	402925	15
11	24	38.4	11/15	32	35.2	6KGP43015X4XBXA1	403194	6KGP43015X4XXXA1	402926	21
15	32	51.2	18.5	37.5	41.25	6KGP43020X4XBXA1	403195	6KGP43020X4XXXA1	402927	21
18.5	37.5	60	22	44	48.4	6KGP43025X4XBXA1	403196	6KGP43025X4XXXA1	402928	22
22	44	70.4	30	61	67.1	6KGP43030X4XBXA1	403197	6KGP43030X4XXXA1	402929	22
30	61	97.6	37	73	80.3	6KGP43040X4XBXA1	403198	6KGP43040X4XXXA1	402930	31
37	73	116.8	45	90	99	6KGP43050X4XBXA1	403199	6KGP43050X4XXXA1	402931	31
45	90	144	55	106	116.6	6KGP43060X4XBXA1	403200	6KGP43060X4XXXA1	402932	31
55	106	169.6	75	147	161.7	6KGP43075X4XBXA1	403201	6KGP43075X4XXXA1	402933	32
75	147	235.2	90	177	194.7	6KGP43100X4XBXA1	403202	6KGP43100X4XXXA1	402934	32



AF-650 GP

IP66, with EMC filter Class A1/B1 (C1/C2)

230V, 3-phase, 50/60Hz input

Heavy Duty rating Nominal motor ratings			Light Duty rating Nominal motor ratings			WITH braking chopper	WITHOUT braking chopper	Unit size
Power kW	Current A	Overload current during 60s (A)	Power kW	Current A	Overload current during 60s (A)	Cat. No. and Ref. No.	Cat. No. and Ref. No.	
0.25	1.8	2.88	0.25	1.8	2.88	6KGP23F33X4RBXA1	6KGP23F33X4RXXA1	15
0.37	2.4	3.84	0.37	2.4	3.84	6KGP23F50X4RBXA1	6KGP23F50X4RXXA1	15
0.75	4.6	7.36	0.75	4.6	7.36	6KGP23001X4RBXA1	6KGP23001X4RXXA1	15
1.5	7.5	12	1.5	7.5	12	6KGP23002X4RBXA1	6KGP23002X4RXXA1	15
2.2	10.6	16.96	2.2	10.6	16.96	6KGP23003X4RBXA1	6KGP23003X4RXXA1	15
3.7	16.7	26.72	3.7	16.7	26.72	6KGP23005X4RBXA1	6KGP23005X4RXXA1	15
5.5	24.2	38.72	5.5/7.5	30.8	33.88	6KGP23007X4RBXA1	6KGP23007X4RXXA1	21
7.5	30.8	49.28	11	46.2	50.82	6KGP23010X4RBXA1	6KGP23010X4RXXA1	21
11	46.2	73.92	15	59.4	65.34	6KGP23015X4RBXA1	6KGP23015X4RXXA1	22
15	59.4	89.1	18.5	74.8	82.28	6KGP23020X4RBXA1	6KGP23020X4RXXA1	31
18.5	74.8	112.2	22	88	96.8	6KGP23025X4RBXA1	6KGP23025X4RXXA1	31
22	88	132	30	115	126.5	6KGP23030X4RBXA1	6KGP23030X4RXXA1	31
30	115	172.5	37	143	157.3	6KGP23040X4RBXA1	6KGP23040X4RXXA1	32
37	143	214.5	45	170	187	6KGP23050X4RBXA1	6KGP23050X4RXXA1	32

400V, 3-phase, 50/60Hz input

Heavy Duty rating Nominal motor ratings			Light Duty rating Nominal motor ratings			WITH braking chopper		WITHOUT braking chopper		Unit size
Power kW	Current A	Overload current during 60s (A)	Power kW	Current A	Overload current during 60s (A)	Cat. No.	Ref. No.	Cat. No.	Ref. No.	
0.37	1.3	2.08	0.37	1.3	1.43	6KGP43F50X4RBXA1	403274	6KGP43F50X4RXXA1	403100	15
0.75	2.4	3.84	0.75	2.4	2.64	6KGP43001X4RBXA1	403275	6KGP43001X4RXXA1	403101	15
1.5	4.1	6.56	1.5	4.1	4.51	6KGP43002X4RBXA1	403276	6KGP43002X4RXXA1	403102	15
2.2	5.6	8.96	2.2	5.6	6.16	6KGP43003X4RBXA1	403277	6KGP43003X4RXXA1	403103	15
4	10	16	4	10	11	6KGP43005X4RBXA1	403278	6KGP43005X4RXXA1	403104	15
5.5	13	20.8	5.5	13	14.3	6KGP43007X4RBXA1	403279	6KGP43007X4RXXA1	403105	15
7.5	16	25.6	7.5	16	17.6	6KGP43010X4RBXA1	403280	6KGP43010X4RXXA1	403106	15
11	24	38.4	11/15	32	35.2	6KGP43015X4RBXA1	403281	6KGP43015X4RXXA1	403107	21
15	32	51.2	18.5	37.5	41.25	6KGP43020X4RBXA1	403282	6KGP43020X4RXXA1	403108	21
18.5	37.5	60	22	44	48.4	6KGP43025X4RBXA1	403283	6KGP43025X4RXXA1	403109	22
22	44	70.4	30	61	67.1	6KGP43030X4RBXA1	403284	6KGP43030X4RXXA1	403110	22
30	61	97.6	37	73	80.3	6KGP43040X4RBXA1	403285	6KGP43040X4RXXA1	403111	31
37	73	116.8	45	90	99	6KGP43050X4RBXA1	403286	6KGP43050X4RXXA1	403112	31
45	90	144	55	106	116.6	6KGP43060X4RBXA1	403287	6KGP43060X4RXXA1	403113	31
55	106	169.6	75	147	161.7	6KGP43075X4RBXA1	403288	6KGP43075X4RXXA1	403114	32
75	147	235.2	90	177	194.7	6KGP43100X4RBXA1	403289	6KGP43100X4RXXA1	403115	32

AF-6 drives

Intro

A

B

C

D

E

F

G

H

I

X



Options and accessories

Field installed IP21 add-on option kits

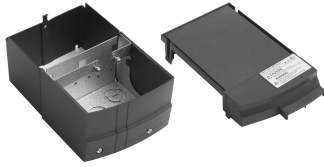

Voltage	Rating kW	IP21 Kit Cat. No.	Ref. No.
230	0.25	NEMA1ACA2	404831
	0.37	NEMA1ACA2	404831
	0.75	NEMA1ACA2	404831
	1.5	NEMA1ACA2	404831
	2.2	NEMA1ACA2	404831
	3.7	NEMA1ACA3	404832
	5.5	NEMA1ACB3	404833
	7.5	NEMA1ACB3	404833
	11	NEMA1ACB4	404834
	15	NEMA1ACB4	404834
	18.5	NEMA1ACC3	404835
	22	NEMA1ACC3	404835
	30	NEMA1ACC4	404836
	37	NEMA1ACC4	404836
400	0.37	NEMA1ACA2	404831
	0.75	NEMA1ACA2	404831
	1.5	NEMA1ACA2	404831
	2.2	NEMA1ACA2	404831
	3.7	NEMA1ACA2	404831
	5.5	NEMA1ACA3	404832
	7.5	NEMA1ACA3	404832
	11	NEMA1ACB3	404833
	15	NEMA1ACB3	404833
	18.5	NEMA1ACB4	404834
	22	NEMA1ACB4	404834
	30	NEMA1ACB4	404834
	37	NEMA1ACC3	404835
	45	NEMA1ACC3	404835
55	NEMA1ACC4	404836	
75	NEMA1ACC4	404836	

Remote mounting kit for graphical LCD keypad



Remote mounting kit for mounting graphical LCD Keypad on enclosure door for AF-650/AF-600. Kit includes gasket, mounting brackets, and cable. Keypad is rated IP65.

Description	Cat. No.	Ref. No.
Remote mounting kit with cable (3m)	RMKYPDAC	404851
Remote mounting kit without cable	OPCRMKNC	404850

Communications modules



Profibus DP communications module Profibus DP internal drive mounted module for use on AF-650 GP and AF-600 FP drives. Supports Profibus DP V1 communications networks.	OPCPDP	404848
DeviceNet communications module DeviceNet internal drive mounted module for use on AF-650 GP and AF-600 FP drives. ODVA certified device.	OPCDEV	404818
Ethernet IP communications module Ethernet IP internal drive mounted module for use on AF-650 GP and AF-600 FP drives. ODVA certified device. Features 2-port built-in switch. Also includes webserver and e-mail notification.	OPCEIP	404820
Modbus TCP communications module Modbus TCP internal drive mounted module for use on AF-650 GP and AF-600 FP drives.	OPCMBTCP	404824
ProfiNet RT communications module ProfiNet RT internal drive mounted module for use on AF-650 GP and AF-600 FP drives.	OPCPRT	404825
Profibus SUB-D9 Adapter Profibus SUB-D9 adapter to connect to SUB-D9 connectors and cables in all installed devices.	OPCTERMD9	409562



Options and accessories (continued)

General purpose I/O module



General purpose I/O internal drive mounted module for use on AF-650 GP and AF-600 FP drives.

Module includes: 3x digital inputs 24V
2x digital outputs PNP/NPN
2x analogue inputs 0-10V
1x analogue output 0/4-20mA

Description	Cat. No.	Ref. No.
General purpose I/O module	OPCGPIO	404821

Programmable Input/Output Module



Programmable I/O module for use on the AF-650GP drive has 3 outputs and 3 inputs to extend the available I/O selection on the control card. It can be used to achieve multi-zone control with 3 pressure transmitters, and provide digital output for driving a relay, input to PLC I/O cards and input to another VFD in sequentially-controlled application.

Programmable I/O Module	OPCPRGIO	409552
-------------------------	----------	--------

Encoder module

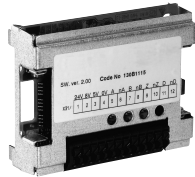

Encoder internal drive mounted module for use on the AF-650 GP drive. Module supports all 5V incremental encoders. Also supports hyperface sincos encoders.

Encoder input module	OPCENC	404819
----------------------	--------	--------

Resolver module

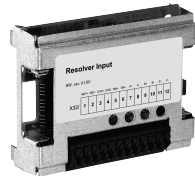

Resolver internal drive mounted module for use on the AF-650 GP drive. Module supports 4-8Vrms, 2.5kHz - 15kHz, 50mA resolvers. Resolution is 10bit at 4Vrms.

Resolver input module	OPCPRES	404852
-----------------------	---------	--------

Relay output module



Relay output internal drive mounted module for use on the AF-650 GP. Module adds (3) Form C relay outputs to the drive. Relays are rated at 2A at 240V resistive load.

Relay output module	OPCRLY	404849
---------------------	--------	--------

24V DC External supply module



24V DC external supply internal drive mounted module for use on the AF-650 GP drives. This module accepts an external 24V DC supply which is used to keep the control board of the drive and other option modules powered in the event of a Line side power outage. Can be used with Communications and I/O Modules.

24V DC External supply module	OPC24VPS	404815
-------------------------------	----------	--------

Options and accessories (continued)

Safe PLC I/O module



Safe PLC I/O internal drive mounted module for use on the AF-650 GP drive. This module provides a safety input based on a single pole 24V DC input.

Description	Cat. No.	Ref. No.
Safe PLC I/O Module	OPCSAFE	404853

Screw terminal accessory



Screw terminal accessory is available for field installation on AF-650 GP drives. These screw terminals can replace the cage clamp terminals which ship with each drive. This set of three terminals are for the digital inputs, analog I/O, and RS485 connection.

Description	Cat. No.	Ref. No.
Screw terminal accessory	OPCSTERM	404822

Pedestal kit



Pedestal kit allows unit size 41h and 42h drives to be floor mounted (IP21 and IP55, 90 to 200/315kW at 400/690V for AF-650 GP).

Description	Cat. No.	Ref. No.
Pedestal kit for unit size 41h	OPCPED41H	409506
Pedestal kit for unit size 42h	OPCPED42H	409507

USB kit



This kit allows for the USB programming terminal to be brought out to the front cover of the drive. Works with all drive types.

For all drives up to unit size 5X	OPCUSB	404861
For all unit size 6X drives	OPCUSB6X	404860

Power shields

These shields are used to cover the drive power terminals on IP21 and IP54/55 drive types.

For Unit size 51 drives	OPCCOVER51	404847
-------------------------	------------	--------



Basic wiring diagrams

AF-6 drives

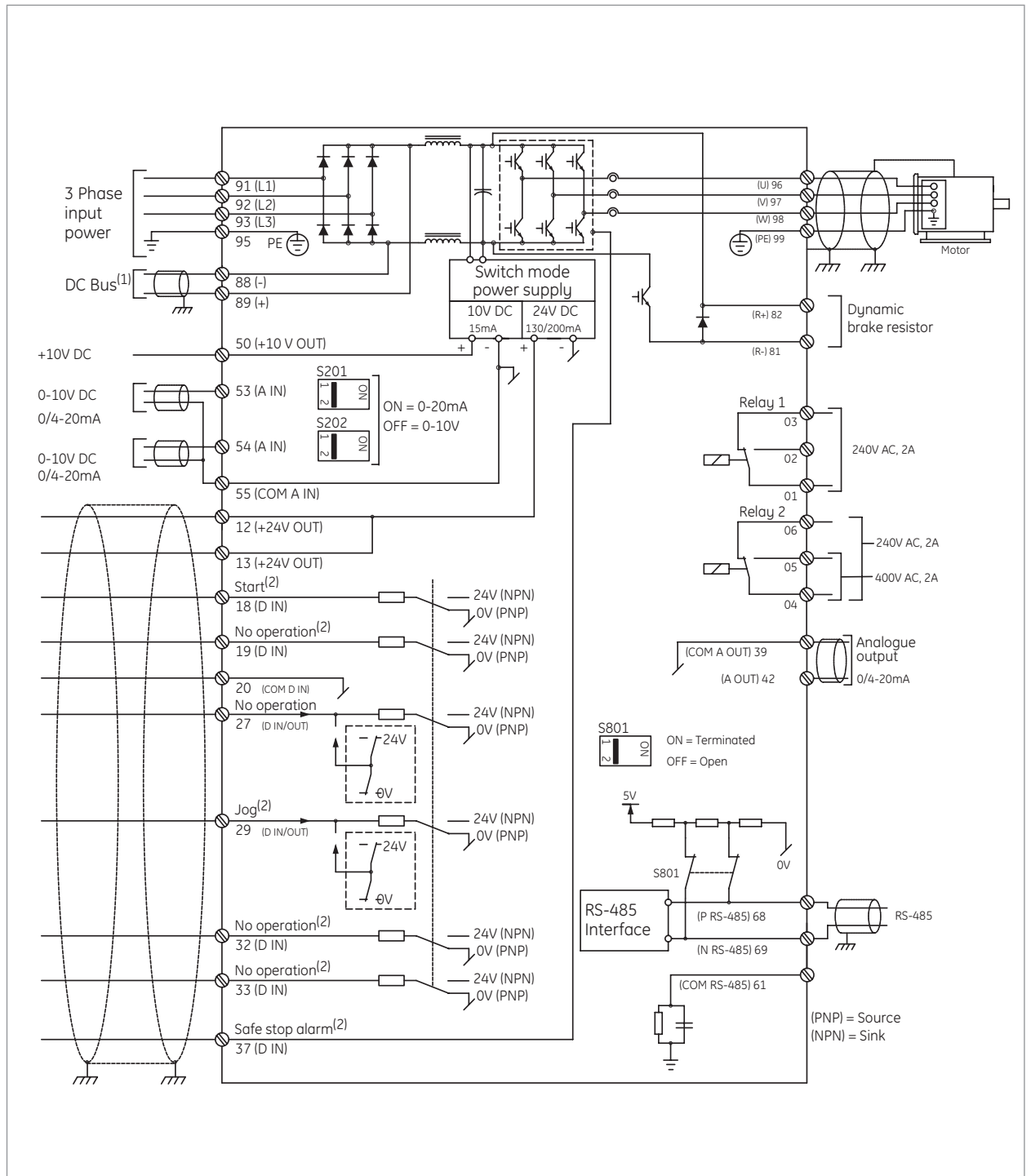

- (1) These terminals are only available with optional factory installed brake chopper.
 (2) Indicates default setting; see parameter group E-## to re-program.



Specifications

Environmental conditions

Enclosures	IP20 chassis, IP00 chassis, IP21, IP55, IP54, IP66
Installation location	For use at altitudes of 1000 m or less without derating
Storage temperature	-25° to 65°C
Ambient temperature	-10° to +50° C for above 45°C, there will be derating; please consult GE
Ambient humidity	5 to 95% RH (non-condensing)
Vibration	1.0G
Cooling method	Fan cooled all ratings. Fan control auto, 50% level, 75% level, 100% level adjustable

Standards

Approvals	CE, UL, cUL, and C-Tick Suitable for use on a circuit capable of delivering not more than 100,000 rms symmetrical amperes for 230V and 400V.
-----------	---

Input power supply

Rated Input AC voltage	200-240 Vac, 3-phase, 50-60 Hz, +/- 10% V 380-500 Vac, 3-phase, 50-60 Hz +/- 10% V 525-690 Vac, 3-phase, 50-60 Hz +/- 10% V
Maximum voltage imbalance	3% of rated supply voltage
True power factor	> 0.9 at rated load
Displacement power factor	> 0.98
Switching on input power supply	Maximum twice/minute up to 7.5kW, maximum once/minute above 7.5kW
Environment according to EN60664-1	Overvoltage category III/pollution degree 2

Output

Rated output voltage	0-100% of supply voltage
Output frequency	0-590 Hz
Switching on output	Unlimited
Accel/decel times	0.01-3600 seconds
Overload current rating	Sinusoidal PWM control (V/Hz, Avd. vector control, sensorless vector, and flux vector with motor feedback)

Control

Starting torque	160% starting torque for 1 minute (constant torque), 110% starting torque for 1 minute (variable torque)
Carrier frequency (motor noise)	Selectable - 1, 1.5, 2, 2.5, 3, 3.5, 4, 5, 6, 7, 8, 10, 12, 14, 16 kHz
Torque boost	Selectable by up to 5 individual V/Hz settings in V/Hz Mode or by 0 - 300% setting of torque boost parameter in Adv. vector mode
Acceleration/deceleration time	0.01-3600 seconds (4 acceleration and deceleration times are selectable via digital inputs. Acceleration and deceleration patterns can be selected from linear or deceleration patterns can be selected from linear or S-curve)
Data protection	Passw protection for quick menu or main menu, 0-9999.
Pattern operation	Settings via built-in logic controller sequencer
Jump frequency control	4 jump (or skip) frequencies via parameter set to avoid mechanical vibration
Slip compensation	Maintains motor at constant speed with load fluctuations
Torque limit control	Output torque can be controlled within a range of 0.0 to 160% (0.1 and steps)
Preset speeds	8 programmable preset speeds selectable by 3 digital inputs
Trim reference setting	Available for speed reference offset via potentiometer, voltage input, or current input
DC injection braking	Starting frequency: 0.0-590 Hz, Braking time: 0.0-60.0 seconds, Braking level: 0-100% of rated current
Jogging operation	Operation via on key or digital input (Fwd or Rev)
Auto-restart after power failure	Restarts the drive without stopping after instantaneous power failure
Energy savings	Controls output voltage to minimize motor loss during constant speed operation
Start mode function	This functionality smoothly catches a spinning motor

Logic controller (LC)

Logic controller events	Up to 37 types of programmable events
Comparators	Array of 6 comparators
Timers	Array of 8 timers, adjustable from 0.0 to 3600 sec
Logic rules	Array of 6 boolean logic rules
Logic controller states	Array of 20 logic controller action states

Process controller (PID)

Feedback select	Up to 2 references. Selectable - no function, motor feedback, separate encoder, encoder option module, or resolver option module
Control	Normal or inverse
Anti windup	Disabled or enabled
Start speed	0.0-200 Hz
Proportional gain	0.00-10.00
Integral time	0.1 - 10000.0 ms
Differential time	0.0 - 10 s

Differential gain	1.0-50.00
Feed forward factor	0-500%
On reference bandwidth	0-200%

Operation

Operation method	Keypad operation: hand, off, auto digital input: programmable for start/stop, forward/reverse, jog timer operation: stop after predetermined time frame Built-in RS-485 Modbus USB port for programming drive with optional PC software
Frequency reference signal	Left or right arrow buttons on keypad in manual mode Speed potentiometer: 0 to +10 Vdc, 10 to 0 Vdc 0-10Vdc analog input 0/4-20mA analog input
References	Up to 3 input references can be selected from analog input #1 or #2, frequency input #1 or #2, network, or potentiometer
Input signals	6x digital inputs, 24 Vdc PNP or NPN 1x safe stop digital input suitable for category 3 installations to meet EN-954-1 2x pulse inputs rated to 110kHz or 1x pulse input and 1 - encoder Input 24 Vdc rated to 4096 PPR 2x analog inputs -10 to +10V scalable or 0/4 to 20 mA scalable
Output signals	2x digital outputs 24 Vdc (digital outputs are used in place of 2 of the digital inputs) 2x form C relays rated to 2A at 230 Vac 1x analog output 0/4 to 20mA
Protective functions	Line phase loss DC overvoltage DC undervoltage Drive overload Motor overtemperature Motor thermistor over-temperature Torque limit Overcurrent Ground fault Short circuit Control word timeout Brake resistor short-circuited Brake chopper short-circuited Brake check DC Link voltage high DC Link voltage low Internal fan fault External fan fault Power board overtemperature
	Missing U phase Missing V phase Missing W phase Internal fault Control voltage fault Auto tune check - wrong motor parameters Auto Tune low inom - motor current is too low Current limit Mechanical brake low Drive initialized to default value Keypad error No motor Soft charge fault Auto tuning fault Serial comms bus fault Hardware mismatch Speed limit

Keypad

Keypad features	LCD display with 6 alpha-numeric lines. multi-language support Hot pluggable, remote mount option, and copycat feature, IP65 rating when remote mounted on enclosure LED's - green - drive is on, yellow - indicates a warning, red - indicates an alarm, amber - indicates active menu keys and h-o-a keys
Password	2 level password protection
Alternate motor parameters	Up to 4 separate complete parameter set-ups are available
Graphical trending	Trend speed, power, frequency or any value programmed in status display

RS485 modbus RTU serial communications

Physical level	EIA/RS485
Transmission distance	500m
Node address	32
Transmission speed	2400, 4800, 9600, 19200, 38400 or 115200 (bits/s)
Transmission mode	Half duplex
Transmission protocol	Modbus RTU
Character code	Binary
Character length	8 bits
Error check	CRC

Mounting clearance

	All AF-650 GP drives can be mounted side-by-side without spacing. For all drives rated 75kW or below allow 100 mm free space above and below. For all drives rated 90kW and above allow 225 mm free space above and below.
--	--



AF-650 GP

Heavy Duty efficiency, Watt loss, unit size, dimensions and weights

230 Vac

Nominal motor ratings		Efficiency			Watt loss (W)	Unit size	Drive type	Height (mm)	Width (mm)	Depth (mm)	Weight (kg)
Power kW	Current A	at 5 kHz (%)	at 4 kHz (%)	at 3 kHz (%)							
0.25	1.8	94			21	12	IP20 chassis	375	90	220	5
0.37	2.4	94			29	12	IP20 chassis	375	90	220	5
0.75	4.6	95			54	12	IP20 chassis	375	90	220	5
1.5	7.5	96			82	12	IP20 chassis	375	90	220	5
2.2	10.6	96			115	12	IP20 chassis	374	130	220	7
3.7	16.7	96			185	13	IP20 chassis	420	165	262	12
5.5	24.2		96.4		239	23	IP20 chassis	420	165	262	12
7.5	30.8		95.9		371	23	IP20 chassis	595	230	242	24
11	46.2		96.4		463	24	IP20 chassis	595	230	242	24
15	59.4		96		621	24	IP20 chassis	630	308	334	35
18.5	74.8			97	740	33	IP20 chassis	630	308	334	35
22	88			97	874	33	IP20 chassis	800	370	334	50
30	115			97	1143	34	IP20 chassis	800	370	334	50
37	143			97	1400	34	IP20 chassis	31.5	14.57	13.15	110.2

400 Vac

0.37	1.3	93			35	12	IP20 chassis	375	90	220	5
0.75	2.4	96			46	12	IP20 chassis	375	90	220	5
1.5	4.1	97			62	12	IP20 chassis	375	90	220	5
2.2	5.6	97			88	12	IP20 chassis	375	90	220	5
3.7	10	97			124	12	IP20 chassis	375	90	220	5
5.5	13	97			187	13	IP20 chassis	375	130	220	7
7.5	16	97			255	13	IP20 chassis	375	130	220	7
11	24		98		291	23	IP20 chassis	420	165	262	12
15	32		98		379	23	IP20 chassis	420	165	262	12
18.5	37.5		98		444	24	IP20 chassis	595	230	242	24
22	44		98		547	24	IP20 chassis	595	230	242	24
30	61			98	570	24	IP20 chassis	595	230	242	24
37	73			98	697	33	IP20 chassis	630	308	334	35
45	90			98	891	33	IP20 chassis	630	308	334	35
55	106			98	1022	34	IP20 chassis	800	370	334	50
75	147			98	1232	34	IP20 chassis	800	370	334	50
90	177			98	2031	43h	IP20 chassis	909	250	375	98
110	212			98	2289	43h	IP20 chassis	909	250	375	98
132	260			98	2923	43h	IP20 chassis	909	250	375	98
160	315			98	3093	44h	IP20 chassis	1122	350	375	116
200	395			98	4039	44h	IP20 chassis	1122	350	375	116
250	480				5005	44h	IP20 chassis	1122	350	375	116
315	600				6796	52	IP00 chassis	1547	585	497.8	313
355	658				7498	52	IP00 chassis	1547	585	497.8	313
400	745				7976	52	IP00 chassis	1547	585	497.8	313
450	800				9031	61	IP21	2282	1400	606	1004
500	80				10146	61	IP21	2282	1400	606	1004
560	990				10649	61	IP21	2282	1400	606	1004
630	1120				12490	61	IP21	2282	1400	606	1004
710	1260				14244	62	IP21	2282	1800	606	1262
800	1460				15466	62	IP21	2282	1800	606	1262

690 Vac

11	13	98			228	22	IP21	650	242	260	27
15	18	98			285	22	IP21	650	242	260	27
18.5	22	98			335	22	IP21	650	242	260	27
22	27	98			375	22	IP21	650	242	260	27
30	34	98			480	32	IP21	770	370	335	65
37	41	98			592	32	IP21	770	370	335	65
45	51	98			720	32	IP21	770	370	335	65
55	62	98			880	32	IP21	770	370	335	65
75	83	98			1800	32	IP21	770	370	335	65
90	108		98		1480	43h	IP20 chassis	909	250	375	98
110	131		98		1800	43h	IP20 chassis	909	250	375	98
132	155		98		2159	43h	IP20 chassis	909	250	375	98
160	192		98		2446	44h	IP20 chassis	1122	350	375	164
200	242		98		3123	44h	IP20 chassis	1122	350	375	164
250	290		98		3771	44h	IP20 chassis	1122	350	375	164
315	344			98	4258	44h	IP20 chassis	1122	350	375	164
355	380			98	4130	52	IP00 chassis	1547	585	497.8	313
400	410			98	4605	52	IP00 chassis	1547	585	497.8	313
500	500			98	6328	52	IP00 chassis	1547	585	497.8	313
560	570			98	7201	52	IP00 chassis	1547	585	497.8	313
630	630	98			7826	61	IP21	2282	1400	606	1004
710	730	98			8983	61	IP21	2282	1400	606	1004
800	850	98			10646	61	IP21	2282	1400	606	1004
900	945	98			11681	62	IP21	2282	1800	606	1262
1000	1060	98			12997	62	IP21	2282	1800	606	1262

AF-6 drives

Intro

A

B

C

D

E

F

G

H

I

X



Dimensional drawings

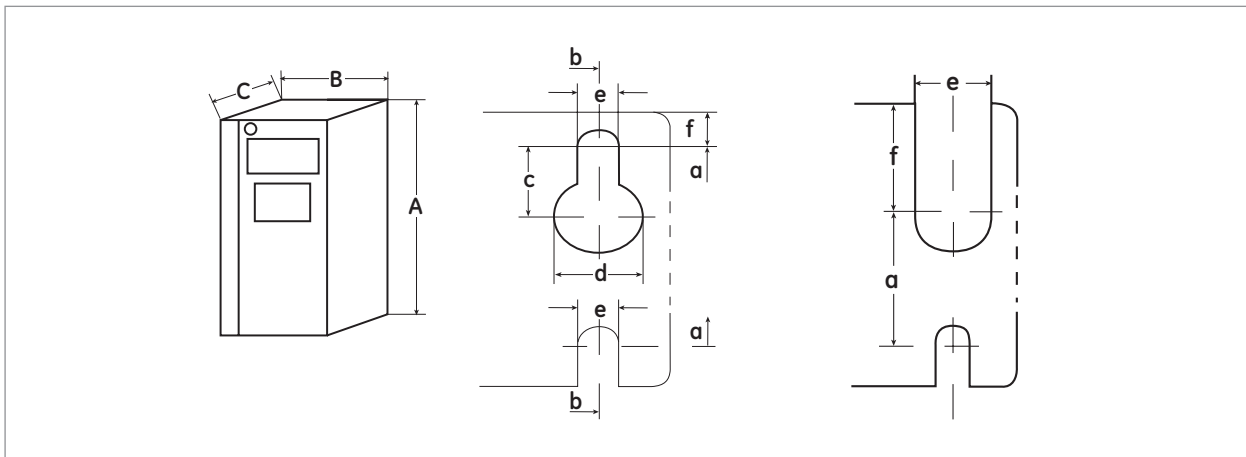

Dimensions, 1X unit sizes (mm)

Unit size		Dimensions	12	13	15 ⁽¹⁾
Enclosure type			IP20	IP20	IP55/IP66
Voltage	230V		0.25 to 2.2kW 1/3 to 3HP	3.7kW 5HP	0.25 to 3.7kW 1/3 to 5HP
	400V		0.37 to 3.7kW 1/2 to 5HP	5.5 to 7.5kW 7.5 to 10HP	0.37 to 7.5kW 1/2 to 10HP
Height	Height of backplate	A	270	270	420
	Height with de-coupling plate	A	375	375	
	Distance between mounting holes	a	257	257	402
Width	Width of backplate	B	90	130	240
	Distance between mounting holes	b	70	110	215
Depth	Depth without I/O and/or network option	C	205	205	195
	Depth with I/O and/or network option	C	220	220	195
Screw holes		c	8.0	8.0	8.3
		d	11.0	11.0	12.0
		e	5.5	5.5	6.5
		f	9.0	9.0	9.0
Weight (kg)			4.9	6.6	13.5 / 14.2

Dimensions, 2X unit sizes (mm)

Unit size		Dimensions	21 ⁽¹⁾	22 ⁽¹⁾	23	24
Enclosure type			IP55/IP66	IP21/IP55/IP66	IP20	IP20
Voltage	230V		5.5 to 7.5kW 7.5 to 10HP	11kW 15HP	5.5 to 7.5kW 7.5 to 10HP	11 to 15kW 15 to 20HP
	400V		11 to 15kW 15 to 20HP	18.5 to 22kW 25 to 30HP	11 to 15kW 15 to 20HP	18.5 to 30kW 25 to 40HP
	690V			11 to 22kW 15 to 30HP		
Height	Height of backplate	A	480	650	400	520
	Height with de-coupling plate	A	-	-	420	595
	Distance between mounting holes	a	455	625	380	495
Width	Width of backplate	B	240	240	165	230
	Distance between mounting holes	b	210	210	140	200
Depth	Depth without I/O and/or network option	C	260	260	250	240
	Depth with I/O and/or network option	C	260	260	260	240
Screw holes		c	12.0	12.0	8.0	-
		d	19.0	19.0	12.0	-
		e	9.0	9.0	6.8	8.5
		f	9.0	9.0	7.9	15.0
Weight (kg)			23.0	27.0	12.0	23.5

(1) IP55/IP66 units need to have cable glands according table on page G.48

Dimensions in mm (inch = mm x 0.03937) - Weight in kg (lb = kg x 2.2046)



Dimensional drawings

Dimensions, 3X unit sizes (mm)

Unit size		Dimensions	31 ⁽²⁾	32 ⁽²⁾	33	34
Enclosure type			IP55/IP66	IP21/IP55/IP66	IP20	IP20
Voltage	230V		15 to 22kW 20 to 30HP	30 to 37kW 40 to 50HP	18.5 to 22kW 25 to 30HP	30 to 37kW 40 to 50HP
	400V		30 to 45kW 40 to 60HP	55 to 75kW 75 to 100HP	37 to 45kW 50 to 60HP	55 to 75kW 75 to 100HP
	690V			30 to 75kW 40 to 100HP		
Height	Height of backplate	A	680	770	550	660
	Height with de-coupling plate	A	-	-	630	800
	Distance between mounting holes	a	650	740	520	630
Width	Width of backplate	B	310	370	310	370
	Distance between mounting holes	b	270	335	270	330
Depth	Depth without I/O and/or network option	C	310	335	335	335
	Depth with I/O and/or network option	C	310	335	335	335
Screw holes		c	12.5	12.5	-	-
		d	19.0	19.0	-	-
		e	9.0	9.0	8.5	8.5
		f	9.8	9.8	17.0	17.0
Weight (kg)			45	65	35	50

AF-6 drives

Dimensions IP20 open chassis drives with field installed IP21 kits⁽¹⁾ (mm)

Unit Size	12	13	23	24	33	34
Enclosure type	IP20 open chassis with IP21 kit					
Voltage						
230V	0.25 to 2.2kW 1/3 to 3HP	3.7kW 5HP	5.5 to 7.5kW 7.5 to 10HP	11 to 15kW 15 to 20HP	18.5 to 22kW 25 to 30HP	30 to 37kW 40 to 50HP
400V	0.25 to 2.2kW 1/2 to 5HP	5.5 to 7.5kW 7.5 to 10HP	11 to 15kW 15 to 20HP	18.5 to 30kW 25 to 40HP	37 to 45kW 50 to 60HP	55 to 75kW 75 to 100HP
Height						
Height with kit	375	375	475	671	754	950
Width						
Width of backplate	94	130	165	231	397	371
Distance between mounting holes	70	110	140	201	269	330
Depth						
Depth without I/O and/or network option	205	205	249	242	338	338
Depth with I/O and/or network option	220	220	262	242	338	338

(1) Please consult IP21 kit Instructions for further mounting details and dimensions.

(2) IP55/IP66 units need to have cable glands according table below (Cable entry overview)

Note: please allow 5cm between drives with field installed IP21 kits. Also, please consult the relevant AF-6 Series drives operating instructions for recommended clearance above and below each drive rating.

Cable entry overview

Unit Size	Enclosure type		Ø26.3	Ø33.1	Ø42.9	knock-outs	Prefix holes
15	IP55	Hole sizes to fit the cable glands	4	-	-	2*26.3	2
15	IP66		4	-	-	2*26.3	2
21	IP55		1	3	-	1*21.5 - 1*17.2	2
21	IP66		1	3	-	1*21.5 - 1*17.2	2
22	IP55		1	1	2	1*21.6	3
22	IP66		1	1	2	1*21.6	3
31	IP55 (400V)		2	1	1	0	-
31	IP55 (200V)		2	2	-	0	-
32	IP55		2	-	2	0	-



Dimensional drawings in mm (inches)

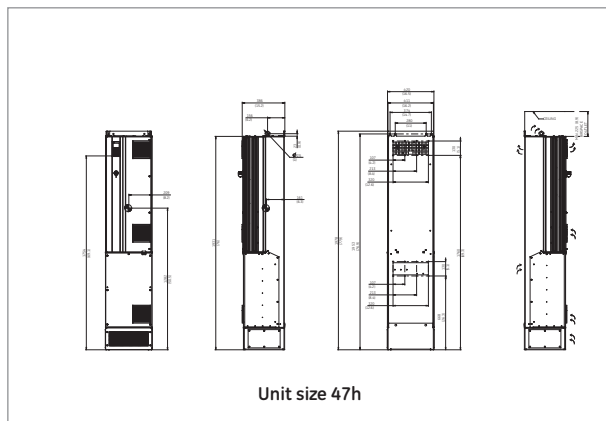
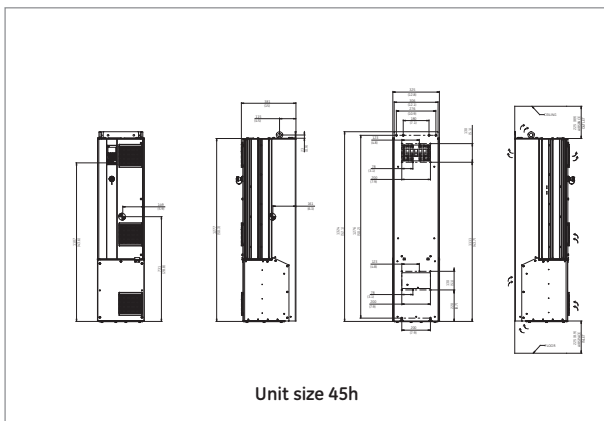
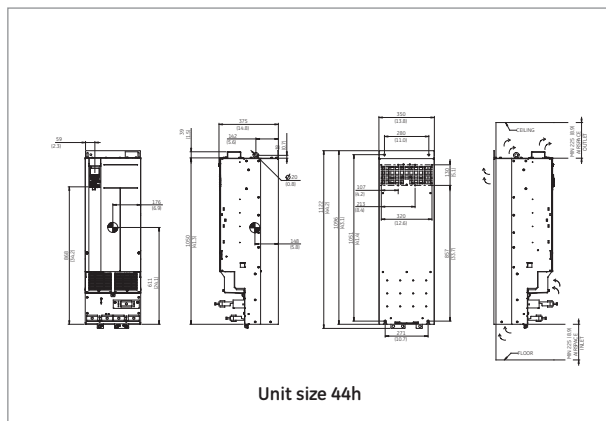
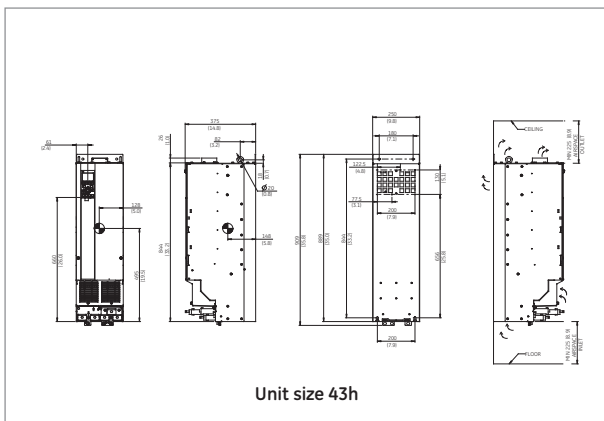
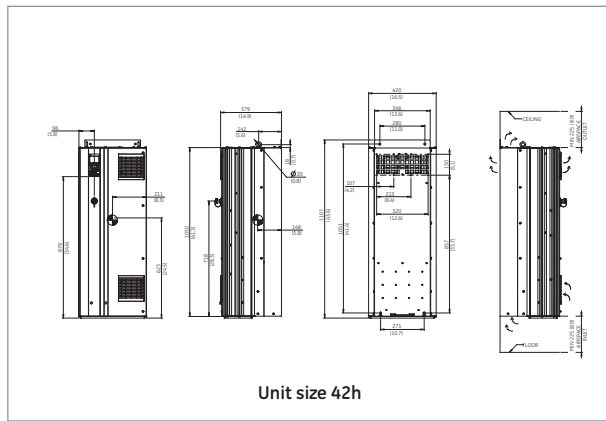
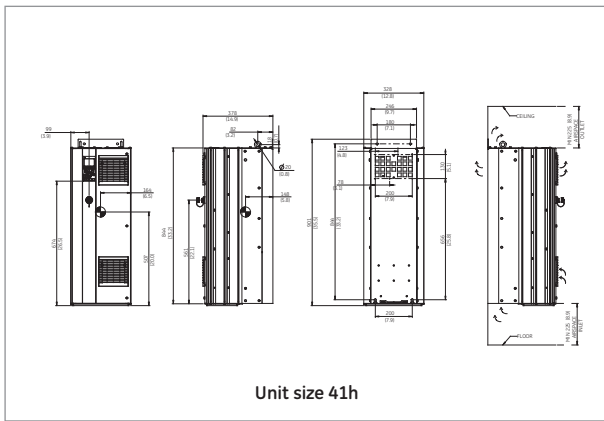

Unit size		41h	42h	43h	44h	45h	47h
Enclosure type		IP21/IP54	IP21/IP54	IP20	IP20	IP21/IP54	IP21/IP54
Voltage	400V	90 to 132kW 125 to 260HP	160 to 250kW 250 to 350HP	90 to 132kW 125 to 200HP	160 to 250kW 250 to 350HP	90 to 132kW 125 to 200HP	160 to 250kW 250 to 350HP
	690V	90 to 132kW 125 to 200HP	160 to 315kW 250 to 450HP	90 to 132kW 125 to 200HP	160 to 315kW 250 to 450HP	90 to 132kW 125 to 200HP	160 to 315kW 250 to 450HP
Shipping dimensions	Height	590	590	590	590	660	660
	Width	1000	1170	1000	1170	1820	2470
	Depth	460	535	460	535	510	590
Drive dimensions	Height	901	1107	909	1122	1324	1978
	Width	325	420	250	350	325	420
	Depth	378	379	375	375	381	386
Weight (kg)		98	164	98	164	116	200

Dimensions in mm (inch = mm x 0.03937) - Weight in kg (lb = kg x 2.2046)



Dimensional drawings in mm (inches)

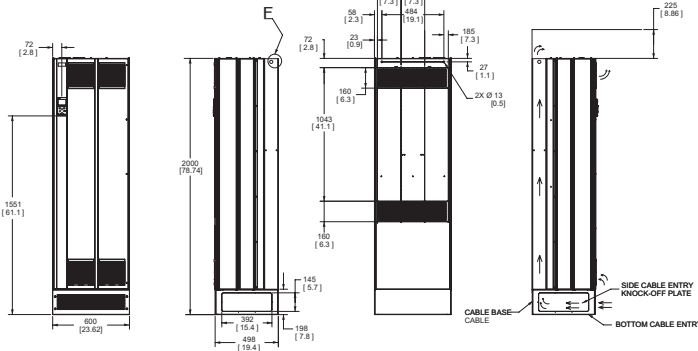

Unit size 51, IP21 and IP54

Unit size 51

Enclosure type	IP21/IP54
Voltage 400V	315 to 400kW 450 to 550HP
690V	355 to 560kW 550 to 750HP
Shipping dimensions	
Height	841
Width	2197
Depth	734
Drive dimensions	
Height	2000
Width	600
Depth	498
Weight (kg)	313

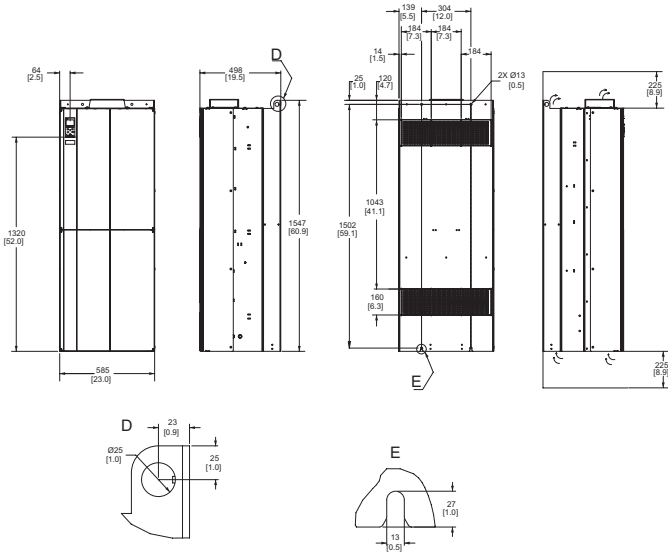

Unit size 52, IP00/Chassis

Unit size 52

Enclosure type	IP00
Voltage 400V	315 to 400kW 450 to 550HP
690V	355 to 560kW 550 to 750HP
Shipping dimensions	
Height	831
Width	1704
Depth	734
Drive dimensions	
Height	1547
Width	585
Depth	498
Weight (kg)	313

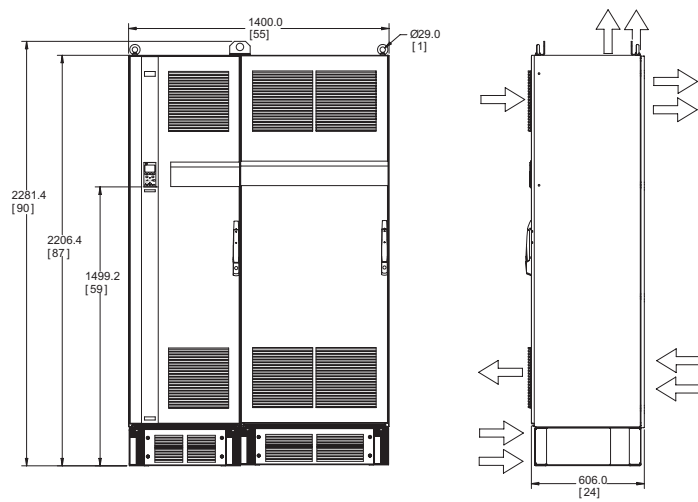

Unit Size 61

Unit size 61

Enclosure type	IP21/IP54
Voltage 400V	450 to 630kW 600 to 900HP
690V	630 to 800kW 900 to 1150HP
Shipping dimensions	
Height	2324
Width	1570
Depth	927
Drive dimensions	
Height	2282
Width	1400
Depth	606
Weight (kg)	1004

Dimensions in mm (inch = mm x 0.03937) - Weight in kg (lb = kg x 2.2046)



Dimensional drawings in mm (inches)

Unit size 62

Enclosure type	IP21/IP55
Voltage	400V 710 to 800kW 1000 to 1200HP
	690V 900 to 1000kW 1250 to 1350HP
Shipping dimensions	
Height	2324
Width	1961
Depth	419
Drive dimensions	
Height	2282
Width	1800
Depth	606
Weight (kg)	1262

Unit size 63 (with options)

Enclosure type	IP21/IP55
Voltage	400V 450 to 630kW 600 to 900HP
	690V 630 to 800kW 900 to 1150HP
Shipping dimensions	
Height	2324
Width	2159
Depth	927
Drive dimensions	
Height	2282
Width	2000
Depth	606
Weight (kg)	1300

Unit size 64 (with options)

Enclosure type	IP21/IP55
Voltage	400V 710 to 800kW 1000 to 1200HP
	690V 900 to 1000kW 1250 to 1350HP
Shipping dimensions	
Height	2324
Width	2543
Depth	927
Drive dimensions	
Height	2282
Width	2400
Depth	606
Weight (kg)	1541

Dimensions in mm (inch = mm x 0.03937) - Weight in kg (lb = kg x 2.2046)



AF-600 FP - Fan and Pump Drives



The AF-600 FP Fan and Pump Drive is a powerful, flexible and easy to use AC variable torque drive.

The drive is available in its standard configuration that includes LCD keypad display that can be remote mounted, DC link reactors, built-in Modbus RTU, Metasys N2, Apogee FLN P1 and RFI Class A2 filter. Available in IP55/IP66 enclosure.

Following models are available:

- Three-phase, 230Vac, from 0.75 to 45kW
- Three-phase, 400Vac, from 0.75 to 1000kW
- Three-phase, 690Vac, from 1.1 to 1400kW

Features

All features HVAC needs

- RFI class A2 filter and DC link reactor as standard configuration.
- Built-in communication networks for ModBus RTU, Metasys N2 and Apogee FLN P1
- Field installed network options: BACnet, LonWorks, Profibus DP, Profinet, Modbus TCP/IP, Ethernet/IP and DeviceNet
- 110% current overload for 1 minute (Light Duty)
- Hot pluggable, illuminated LCD display, unit indications, rotation direction indication, trended charts display speed, torque, current, full alarm messages & descriptions
- 4 auto-tuning PID controllers
- Integrated logic control, PLC
- Flying start (catch a spinning motor)
- Easy to use PC software
- Energy monitoring feature
- Flow compensation
- Pump cascade controller
- Sleep mode
- Fan belt monitoring
- Stairwell pressurization
- Fire override mode
- High standard protection Class 3C2 as standard, optional class 3C3

Approvals / Marking



UL, cUL, C-Tick, EAC

Applications

Fan

HVAC, cooling towers, VAV, supply and return, exhaust, fume hood, make-up air, induced and forced draft, furnace temperature control.

Pump

Chilled water, pressure boosting, cooling tower, wastewater, chiller, irrigation, hydro-storage.

Product numbering system diagram

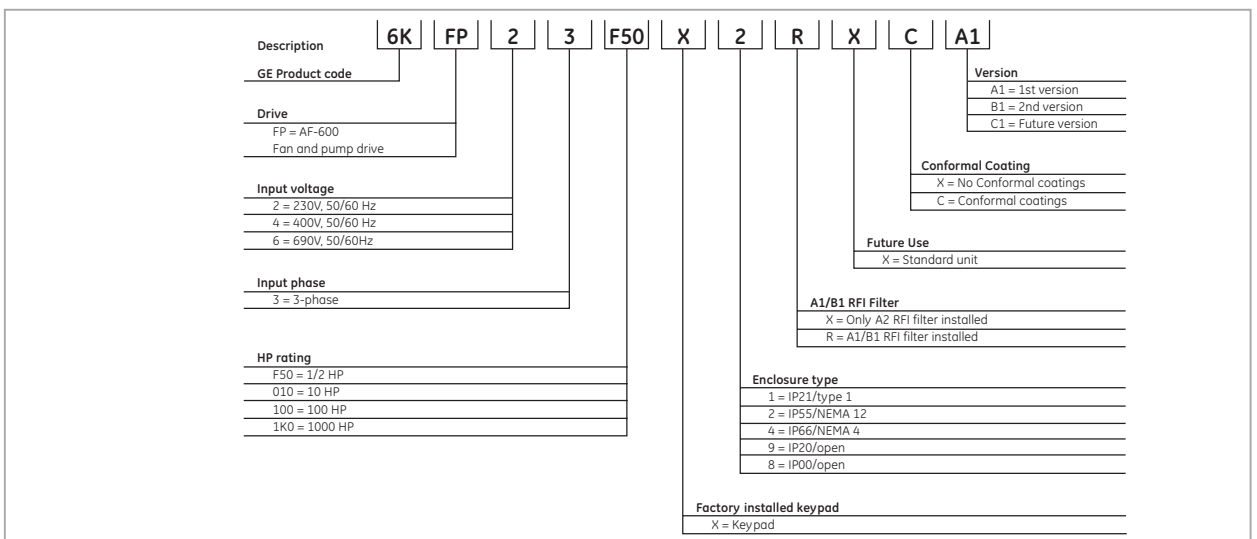

Product number for illustrative purposes only



**IP00 / IP20 / IP21, with EMC filter Class A2 (C3)
230V, 3-phase, 50/60Hz input**

Nominal motor ratings			Enclosure type ⁽²⁾ :	Cat. No.	Ref. No.	Unit size
Power kW	Current A	Overload current (A) (110% 1 Min)				
0.75	4.6	5.1	IP20	6KFP23001X9XXXXA1	404684	12
1.5	7.5	8.3		6KFP23002X9XXXXA1	404685	12
2.2	10.6	11.7		6KFP23003X9XXXXA1	404686	12
3.7	16.7	18.4		6KFP23005X9XXXXA1	404687	13
5.5	24.2	26.6		6KFP23007X9XXXXA1	404688	23
7.5	30.8	33.9		6KFP23010X9XXXXA1	404689	23
11	46.2	50.8		6KFP23015X9XXXXA1	404690	23
15	59.4	65.3		6KFP23020X9XXXXA1	404691	24
18.5	74.8	82.3		6KFP23025X9XXXXA1	404692	24
22	88	96.8		6KFP23030X9XXXXA1	404693	33
30	115	126.5		6KFP23040X9XXXXA1	404694	33
37	143	157		6KFP23050X9XXXXA1	404695	34
45	170	187		6KFP23060X9XXXXA1	404696	34

400V, 3-phase, 50/60Hz input

Nominal motor ratings			Enclosure type ⁽²⁾ :	Cat. No.	Ref. No.	Unit size
Power kW	Current A	Overload current (A) (110% 1 Min)				
0.75	2.4	2.64	IP20	6KFP43001X9XXXXA1	403855	12
1.5	4.1	4.51		6KFP43002X9XXXXA1	403856	12
2.2	5.6	6.16		6KFP43003X9XXXXA1	403857	12
4	10	11		6KFP43005X9XXXXA1	403858	12
5.5	13	14.3		6KFP43007X9XXXXA1	403859	13
7.5	16	17.6		6KFP43010X9XXXXA1	403860	13
11	24	26.4		6KFP43015X9XXXXA1	403861	23
15	32	35.2		6KFP43020X9XXXXA1	403862	23
18.5	37.5	41.25		6KFP43025X9XXXXA1	403863	23
22	44	48.4		6KFP43030X9XXXXA1	403864	24
30	61	67.1		6KFP43040X9XXXXA1	403865	24
37	73	80.3		6KFP43050X9XXXXA1	403866	24
45	90	99		6KFP43060X9XXXXA1	403867	33
55	106	116.6		6KFP43075X9XXXXA1	403868	33
75	147	161.7		6KFP43100X9XXXXA1	403869	34
90	177	194.7		6KFP43125X9XXXXA1	403870	34
110	212	233.2	IP20 conformal coated	6KFP43150X9XXCB1	409679	43h
132	260	286		6KFP43200X9XXCB1	409680	43h
160	315	346.5	IP00 conformal coated	6KFP43250X9XXCB1	409682	43h
200	395	434.5		6KFP43300X9XXCB1	409683	44h
250	480	528	IP21 conformal coated	6KFP43350X9XXCB1	409684	44h
315	588	646.8		6KFP43450X9XXCB1	409685	44h
355	658	723.8	IP00 conformal coated	6KFP43500X8XXCA1	403877	52
400	745	819.5		6KFP43550X8XXCA1	403878	52
450	800	880	IP21 conformal coated	6KFP43600X8XXCA1	403879	52
500	880	968		6KFP43650X1XXCA1	403880	61
560	990	1089	IP21 conformal coated	6KFP43750X1XXCA1	403881	61
630	1120	1232		6KFP43900X1XXCA1	403882	61
710	1260	1386		6KFP431K0X1XXCA1	403883	61
800	1460	1606		6KFP431K2X1XXCA1	403884	62
1000	1720	1892		6KFP431K3X1XXCA1	403885	62

690V, 3-phase, 50/60Hz input

Nominal motor ratings			Enclosure type ⁽²⁾ :	Cat. No. and Ref. No.	Unit size	
Power kW	Current A	Overload current (A) (110% 1 Min)				
11	13	14.3	IP21 conformal coated	6KFP43015X1XXCA1	22	
15	18	19.8		6KFP43020X1XXCA1	22	
18.5	22	24.2		6KFP43025X1XXCA1	22	
22	27	29.7		6KFP43030X1XXCA1	22	
30	34	37.4		6KFP43040X1XXCA1	22	
37	41	45.1		6KFP43050X1XXCA1	32	
45	52	57.2		6KFP43060X1XXCA1	32	
55	62	68.2		6KFP43075X1XXCA1	32	
75	83	91.3		6KFP43100X1XXCA1	32	
90	108	118.8		6KFP43125X1XXCA1	32	
110	131	144.1		IP20 conformal coated	6KFP43150X9XXCB1	43h
132	155	170.5			6KFP43200X9XXCB1	43h
160	192	211.2		IP20 conformal coated	6KFP43250X9XXCB1	43h
200	242	266.2			6KFP43300X9XXCB1	44h
250	290	319		IP00 conformal coated	6KFP43350X9XXCB1	44h
315	344	378.4			6KFP43450X9XXCB1	44h
400	400	440	IP00 conformal coated	6KFP43550X9XXCB1	44h	
450	450	495		6KFP43600X8XXCA1	52	
500	500	550	IP00 conformal coated	6KFP43650X8XXCA1	52	
560	570	627		6KFP43750X8XXCA1	52	
630	630	693	IP21 conformal coated	6KFP43900X8XXCA1	52	
710	730	803		6KFP431K0X1XXCA1	61	
800	850	935	IP21 conformal coated	6KFP431K1X1XXCA1	61	
900	945	1039.5		6KFP431K2X1XXCA1	61	
1000	1060	1166		6KFP431K3X1XXCA1	63	
1200	1260	1386		6KFP431K6X1XXCA1	63	
1400	1415	1556.5	6KFP431K9X1XXCA1	63		

(1) Drives are rated IP21 without the need for a separate kit.

(2) IP21 kits are available as field installed options for all 230V drives from 1.1 to 45kW and for all 400V drives from 1.1 to 90kW. See page G.59.



IP00 / IP20 / IP21, with EMC filter Class A1/B1 (C1/C2) 230V, 3-phase, 50/60Hz input

Nominal motor ratings			Enclosure type ⁽²⁾ :	Cat. No. and Ref. No.	Unit size
Power kW	Current A	Overload current (A) (110% 1 Min)			
0.75	4.6	5.1	IP20	6KFP23001X9RXXA1	12
1.5	7.5	8.3		6KFP23002X9RXXA1	12
2.2	10.6	11.7		6KFP23003X9RXXA1	12
3.7	16.7	18.4		6KFP23005X9RXXA1	13
5.5	24.2	26.6		6KFP23007X9RXXA1	23
7.5	30.8	33.9		6KFP23010X9RXXA1	23
11	46.2	50.8		6KFP23015X9RXXA1	23
15	59.4	65.3		6KFP23020X9RXXA1	24
18.5	74.8	82.3		6KFP23025X9RXXA1	24
22	88	96.8		6KFP23030X9RXXA1	33
30	115	126.5		6KFP23040X9RXXA1	33
37	143	157		6KFP23050X9RXXA1	34
45	170	187		6KFP23060X9RXXA1	34

400V, 3-phase, 50/60Hz input

Nominal motor ratings			Enclosure type ⁽²⁾ :	Cat. No.	Ref. No.	Unit size	
Power kW	Current A	Overload current (A) (110% 1 Min)					
0.75	2.4	2.64	IP20	6KFP43001X9RXXA1	403973	12	
1.5	4.1	4.51		6KFP43002X9RXXA1	403974	12	
2.2	5.6	6.16		6KFP43003X9RXXA1	403975	12	
4	10	11		6KFP43005X9RXXA1	403976	12	
5.5	13	14.3		6KFP43007X9RXXA1	403977	13	
7.5	16	17.6		6KFP43010X9RXXA1	403978	13	
11	24	26.4		6KFP43015X9RXXA1	403979	23	
15	32	35.2		6KFP43020X9RXXA1	403980	23	
18.5	37.5	41.25		6KFP43025X9RXXA1	403981	23	
22	44	48.4		6KFP43030X9RXXA1	403982	24	
30	61	67.1		6KFP43040X9RXXA1	403983	24	
37	73	80.3		6KFP43050X9RXXA1	403984	24	
45	90	99		6KFP43060X9RXXA1	403985	33	
55	106	116.6		6KFP43075X9RXXA1	403986	33	
75	147	161.7		6KFP43100X9RXXA1	403987	34	
90	177	194.7		6KFP43125X9RXXA1	403988	34	
110	212	233.2	IP20 conformal coated	6KFP43150X9RXC1	409692	43h	
132	260	286		6KFP43200X9RXC1	409693	43h	
160	315	346.5	IP00 conformal coated	6KFP43250X9RXC1	409694	43h	
200	395	434.5		6KFP43300X9RXC1	409695	44h	
250	480	528		6KFP43350X9RXC1	409700	44h	
315	588	646.8	IP21 conformal coated	6KFP43450X9RXC1	409702	44h	
355	658	723.8		6KFP43500X8RXC1	403995	52	
400	745	819.5	IP00 conformal coated	6KFP43550X8RXC1	403996	52	
450	800	880		6KFP43600X8RXC1	403997	52	
500	880	968		6KFP43650X1RXC1	403998	63	
560	990	1089		6KFP43750X1RXC1	403999	63	
630	1120	1232		IP21 conformal coated	6KFP43900X1RXC1	404000	63
710	1260	1386			6KFP431K0X1RXC1	404205	63
800	1460	1606			6KFP431K2X1RXC1	404206	64
1000	1720	1892			6KFP431K3X1RXC1	404208	61

690V, 3-phase, 50/60Hz input

Nominal motor ratings			Enclosure type ⁽²⁾ :	Cat. No. and Ref. No.	Unit size	
Power kW	Current A	Overload current (A) (110% 1 Min)				
11	13	14.3	IP21 conformal coated	6KFP43015X1RXC1	22	
15	18	19.8		6KFP43020X1RXC1	22	
18.5	22	24.2		6KFP43025X1RXC1	22	
22	27	29.7		6KFP43030X1RXC1	22	
30	34	37.4		6KFP43040X1RXC1	22	
37	41	45.1		6KFP43050X1RXC1	32	
45	52	57.2		6KFP43060X1RXC1	32	
55	62	68.2		6KFP43075X1RXC1	32	
75	83	91.3		6KFP43100X1RXC1	32	
90	108	118.8		6KFP43125X1RXC1	32	
110	131	144.1		IP20 conformal coated	6KFP43150X9RXC1	43h
132	155	170.5			6KFP43200X9RXC1	43h
160	192	211.2		IP20 conformal coated	6KFP43250X9RXC1	43h
200	242	266.2			6KFP43300X9RXC1	44h
250	290	319			6KFP43350X9RXC1	44h
315	344	378.4		IP00 conformal coated	6KFP43450X9RXC1	44h
400	400	440	6KFP43550X9RXC1		44h	
450	450	495	IP00 conformal coated	6KFP43600X8RXC1	52	
500	500	550		6KFP43650X8RXC1	52	
560	570	627		6KFP43750X8RXC1	52	
630	630	693		6KFP43900X8RXC1	52	
710	730	803		IP21 conformal coated	6KFP431K0X1RXC1	62
800	850	935			6KFP431K1X1RXC1	62
900	945	1039.5			6KFP431K2X1RXC1	62
1000	1060	1166			6KFP431K3X1RXC1	64
1200	1260	1386	IP21 conformal coated	6KFP431K6X1RXC1	64	
1400	1415	1556.5		6KFP431K9X1RXC1	64	

(1) Drives are rated IP21 without the need for a separate kit.

(2) IP21 kits are available as field installed options for all 230V drives from 1.1 to 45kW and for all 400V drives from 1.1 to 90kW. See page G.59.



IP54 / IP55, with EMC filter Class A2 (C3)
230V, 3-phase, 50/60Hz input

Nominal motor ratings			Enclosure type ⁽²⁾ :	Cat. No.	Ref. No.	Unit size
Power kW	Current A	Overload current (A) (110% 1 Min)				
0.75	4.6	5.1	IP55	6KFP23001X2XXXA1	404697	12
1.5	7.5	8.3		6KFP23002X2XXXA1	404698	12
2.2	10.6	11.7		6KFP23003X2XXXA1	404699	12
3.7	16.7	18.4		6KFP23005X2XXXA1	404700	13
5.5	24.2	26.6		6KFP23007X2XXXA1	404701	23
7.5	30.8	33.9		6KFP23010X2XXXA1	404702	23
11	46.2	50.8		6KFP23015X2XXXA1	404703	23
15	59.4	65.3		6KFP23020X2XXXA1	404704	24
18.5	74.8	82.3		6KFP23025X2XXXA1	404705	24
22	88	96.8		6KFP23030X2XXXA1	404706	33
30	115	126.5		6KFP23040X2XXXA1	404707	33
37	143	157		6KFP23050X2XXXA1	404708	34
45	170	187		6KFP23060X2XXXA1	404709	34

400V, 3-phase, 50/60Hz input

Nominal motor ratings			Enclosure type ⁽²⁾ :	Cat. No.	Ref. No.	Unit size
Power kW	Current A	Overload current (A) (110% 1 Min)				
0.75	2.4	2.64	IP55	6KFP43001X2XXXA1	403886	15
1.5	4.1	4.51		6KFP43002X2XXXA1	403887	15
2.2	5.6	6.16		6KFP43003X2XXXA1	403888	15
4	10	11		6KFP43005X2XXXA1	403889	15
5.5	13	14.3		6KFP43007X2XXXA1	403890	15
7.5	16	17.6		6KFP43010X2XXXA1	403891	15
11	24	26.4		6KFP43015X2XXXA1	403892	15
15	32	35.2		6KFP43020X2XXXA1	403893	21
18.5	37.5	41.25		6KFP43025X2XXXA1	403894	21
22	44	48.4		6KFP43030X2XXXA1	403895	22
30	61	67.1		6KFP43040X2XXXA1	403896	22
37	73	80.3		6KFP43050X2XXXA1	403897	31
45	90	99		6KFP43060X2XXXA1	403898	31
55	106	116.6		6KFP43075X2XXXA1	403899	31
75	147	161.7		6KFP43100X2XXXA1	403900	32
90	177	194.7		6KFP43125X2XXXA1	403901	32
110	212	233.2	IP54 conformal coated	6KFP43150X2XXCB1	409686	41h
132	260	286		6KFP43200X2XXCB1	409687	41h
160	315	346.5		6KFP43250X2XXCB1	409688	41h
200	395	434.5		6KFP43300X2XXCB1	409689	42h
250	480	528		6KFP43350X2XXCB1	409690	42h
315	588	646.8		6KFP43450X2XXCB1	409691	42h
355	658	723.8		6KFP43500X2XXCA1	403908	52
400	745	819.5		6KFP43550X2XXCA1	403909	52
450	800	880		6KFP43600X2XXCA1	403910	52
500	880	968		6KFP43650X2XXCA1	403911	61
560	990	1089		6KFP43750X2XXCA1	403912	61
630	1120	1232		6KFP43900X2XXCA1	403913	61
710	1260	1386		6KFP431K0X2XXCA1	403914	61
800	1460	1606		6KFP431K2X2XXCA1	403915	62
1000	1720	1892	6KFP431K3X2XXCA1	403916	62	

690V, 3-phase, 50/60Hz input

Nominal motor ratings			Enclosure type ⁽²⁾ :	Cat. No. and Ref. No.	Unit size
Power kW	Current A	Overload current (A) (110% 1 Min)			
11	13	14.3	IP55 conformal coated	6KFP43015X2XXCA1	22
15	18	19.8		6KFP43020X2XXCA1	22
18.5	22	24.2		6KFP43025X2XXCA1	22
22	27	29.7		6KFP43030X2XXCA1	22
30	34	37.4		6KFP43040X2XXCA1	22
37	41	45.1		6KFP43050X2XXCA1	32
45	52	57.2		6KFP43060X2XXCA1	32
55	62	68.2		6KFP43075X2XXCA1	32
75	83	91.3		6KFP43100X2XXCA1	32
90	108	118.8		6KFP43125X2XXCA1	32
110	131	144.1		6KFP43150X2XXCB1	41h
132	155	170.5		6KFP43200X2XXCB1	41h
160	192	211.2		6KFP43250X2XXCB1	41h
200	242	266.2		6KFP43300X2XXCB1	42h
250	290	319		6KFP43350X2XXCB1	42h
315	344	378.4		6KFP43450X2XXCB1	42h
400	400	440	6KFP43550X2XXCB1	42h	
450	450	495	IP54 conformal coated	6KFP43600X2XXCA1	51
500	500	550		6KFP43650X2XXCA1	51
560	570	627		6KFP43750X2XXCA1	51
630	630	693		6KFP43900X2XXCA1	51
710	730	803		6KFP431K0X2XXCA1	61
800	850	935		6KFP431K1X2XXCA1	61
900	945	1039.5		6KFP431K2X2XXCA1	61
1000	1060	1166		6KFP431K3X2XXCA1	63
1200	1260	1386		6KFP431K6X2XXCA1	63
1400	1415	1556.5		6KFP431K9X2XXCA1	63

(1) Drives are rated IP21 without the need for a separate kit.

(2) IP21 kits are available as field installed options for all 230V drives from 1.1 to 45kW and for all 400V drives from 1.1 to 90kW. See page G.59.



AF-600 FP

IP54 / IP55, with EMC filter Class A1/B1 (C1/C2)

230V, 3-phase, 50/60Hz input

Nominal motor ratings			Enclosure type ⁽²⁾ :	Cat. No. and Ref. No.	Unit size
Power kW	Current A	Overload current (A) (110% 1 Min)			
0.75	4.6	5.1	IP55	6KFP23001X2RXXA1	15
1.5	7.5	8.3		6KFP23002X2RXXA1	15
2.2	10.6	11.7		6KFP23003X2RXXA1	15
3.7	16.7	18.4		6KFP23005X2RXXA1	15
5.5	24.2	26.6		6KFP23007X2RXXA1	15
7.5	30.8	33.9		6KFP23010X2RXXA1	21
11	46.2	50.8		6KFP23015X2RXXA1	21
15	59.4	65.3		6KFP23020X2RXXA1	22
18.5	74.8	82.3		6KFP23025X2RXXA1	31
22	88	96.8		6KFP23030X2RXXA1	31
30	115	126.5		6KFP23040X2RXXA1	31
37	143	157		6KFP23050X2RXXA1	32
45	170	187		6KFP23060X2RXXA1	32

400V, 3-phase, 50/60Hz input

Nominal motor ratings			Enclosure type ⁽²⁾ :	Cat. No.	Ref. No.	Unit size
Power kW	Current A	Overload current (A) (110% 1 Min)				
0.75	2.4	2.64	IP55	6KFP43001X2RXXA1	404209	15
1.5	4.1	4.51		6KFP43002X2RXXA1	404210	15
2.2	5.6	6.16		6KFP43003X2RXXA1	404263	15
4	10	11		6KFP43005X2RXXA1	404293	15
5.5	13	14.3		6KFP43007X2RXXA1	404387	15
7.5	16	17.6		6KFP43010X2RXXA1	404388	15
11	24	26.4		6KFP43015X2RXXA1	404389	21
15	32	35.2		6KFP43020X2RXXA1	404464	21
18.5	37.5	41.25		6KFP43025X2RXXA1	404465	21
22	44	48.4		6KFP43030X2RXXA1	404466	22
30	61	67.1		6KFP43040X2RXXA1	404467	22
37	73	80.3		6KFP43050X2RXXA1	404468	31
45	90	99		6KFP43060X2RXXA1	404469	31
55	106	116.6		6KFP43075X2RXXA1	404470	31
75	147	161.7		6KFP43100X2RXXA1	404471	32
90	177	194.7		6KFP43125X2RXXA1	404472	32
110	212	233.2	6KFP43150X2RXC1	409703	41h	
132	260	286	6KFP43200X2RXC1	409704	41h	
160	315	346.5	6KFP43250X2RXC1	409705	41h	
200	395	434.5	6KFP43300X2RXC1	409706	42h	
250	480	528	6KFP43350X2RXC1	409707	42h	
315	588	646.8	6KFP43450X2RXC1	409708	42h	
355	658	723.8	6KFP43500X2RXC1	404528	51	
400	745	819.5	6KFP43550X2RXC1	404529	51	
450	800	880	6KFP43600X2RXC1	404532	51	
500	880	968	6KFP43650X2RXC1	404533	63	
560	990	1089	6KFP43750X2RXC1	404534	63	
630	1120	1232	6KFP43900X2RXC1	404535	63	
710	1260	1386	6KFP431K0X2RXC1	404536	63	
800	1460	1606	6KFP431K2X2RXC1	404537	64	
1000	1720	1892	6KFP431K3X2RXC1	404538	64	

690V, 3-phase, 50/60Hz input

Nominal motor ratings			Enclosure type ⁽²⁾ :	Cat. No. and Ref. No.	Unit size
Power kW	Current A	Overload current (A) (110% 1 Min)			
11	13	14.3	IP55 conformal coated	6KFP43015X2RXC1	15
15	18	19.8		6KFP43020X2RXC1	21
18.5	22	24.2		6KFP43025X2RXC1	21
22	27	29.7		6KFP43030X2RXC1	22
30	34	37.4		6KFP43040X2RXC1	22
37	41	45.1		6KFP43050X2RXC1	31
45	52	57.2		6KFP43060X2RXC1	31
55	62	68.2		6KFP43075X2RXC1	31
75	83	91.3		6KFP43100X2RXC1	32
90	108	118.8		6KFP43125X2RXC1	32
110	131	144.1		6KFP43150X2RXC1	41h
132	155	170.5		6KFP43200X2RXC1	41h
160	192	211.2		6KFP43250X2RXC1	41h
200	242	266.2		6KFP43300X2RXC1	42h
250	290	319		6KFP43350X2RXC1	42h
315	344	378.4		6KFP43450X2RXC1	42h
400	400	440	6KFP43550X2RXC1	51	
450	450	495	6KFP43600X2RXC1	51	
500	500	550	6KFP43650X2RXC1	51	
560	570	627	6KFP43750X2RXC1	51	
630	630	693	6KFP43900X2RXC1	15	
710	730	803	6KFP431K0X2RXC1	62	
800	850	935	6KFP431K1X2RXC1	62	
900	945	1039.5	6KFP431K2X2RXC1	62	
1000	1060	1166	6KFP431K3X2RXC1	64	
1200	1260	1386	6KFP431K6X2RXC1	64	
1400	1415	1556.5	6KFP431K9X2RXC1	64	

(1) Drives are rated IP21 without the need for a separate kit.

(2) IP21 kits are available as field installed options for all 230V drives from 1.1 to 45kW and for all 400V drives from 1.1 to 90kW. See page G.59.

AF-6 drives

Intro

A

B

C

D

E

F

G

H

I

X



IP66, with EMC filter Class A2 (C3)

230V, 3-phase, 50/60Hz input

Nominal motor ratings			Enclosure type ⁽²⁾ :	Cat. No. and Ref. No.	Unit size
Power kW	Current A	Overload current (A) (110% 1 Min)			
0.75	4.6	5.1	IP66 Conformal coated	6KFP23001X4XXCA1	15
1.5	7.5	8.3		6KFP23002X4XXCA1	15
2.2	10.6	11.7		6KFP23003X4XXCA1	15
3.7	16.7	18.4		6KFP23005X4XXCA1	15
5.5	24.2	26.6		6KFP23007X4XXCA1	15
7.5	30.8	33.9		6KFP23010X4XXCA1	21
11	46.2	50.8		6KFP23015X4XXCA1	21
15	59.4	65.3		6KFP23020X4XXCA1	22
18.5	74.8	82.3		6KFP23025X4XXCA1	31
22	88	96.8		6KFP23030X4XXCA1	31
30	115	126.5		6KFP23040X4XXCA1	31
37	143	157		6KFP23050X4XXCA1	32
45	170	187		6KFP23060X4XXCA1	32

400V, 3-phase, 50/60Hz input

Nominal motor ratings			Enclosure type ⁽²⁾ :	Cat. No. and Ref. No.	Unit size
Power kW	Current A	Overload current (A) (110% 1 Min)			
0.75	1.3	1.43	IP66 Conformal coated	6KFP43001X4XXCA1	15
1.5	2.4	2.64		6KFP43002X4XXCA1	15
2.2	4.1	4.51		6KFP43003X4XXCA1	15
4	5.6	6.16		6KFP43005X4XXCA1	15
5.5	10	11		6KFP43007X4XXCA1	15
7.5	13	14.3		6KFP43010X4XXCA1	15
11	16	17.6		6KFP43015X4XXCA1	21
15	32	35.2		6KFP43020X4XXCA1	21
18.5	37.5	41.25		6KFP43025X4XXCA1	21
22	44	48.4		6KFP43030X4XXCA1	22
30	61	67.1		6KFP43040X4XXCA1	22
37	73	80.3		6KFP43050X4XXCA1	31
45	90	99		6KFP43060X4XXCA1	31
55	106	116.6		6KFP43075X4XXCA1	31
75	147	161.7		6KFP43100X4XXCA1	32
90	177	194.7		6KFP43125X4XXCA1	32

(1) Drives are rated IP21 without the need for a separate kit.

(2) IP21 kits are available as field installed options for all 230V drives from 1.1 to 45kW and for all 400V drives from 1.1 to 90kW. See page G.59.



AF-600 FP

IP66, with EMC filter Class A1/B1 (C1/C2)

230V, 3-phase, 50/60Hz input

Nominal motor ratings			Enclosure type ⁽²⁾ :	Cat. No. and Ref. No.	Unit size
Power kW	Current A	Overload current (A) (110% 1 Min)			
0.75	4.6	5.1	IP66 Conformal Coated	6KFP23001X4RXCA1	15
1.5	7.5	8.3		6KFP23002X4RXCA1	15
2.2	10.6	11.7		6KFP23003X4RXCA1	15
3.7	16.7	18.4		6KFP23005X4RXCA1	15
5.5	24.2	26.6		6KFP23007X4RXCA1	15
7.5	30.8	33.9		6KFP23010X4RXCA1	21
11	46.2	50.8		6KFP23015X4RXCA1	21
15	59.4	65.3		6KFP23020X4RXCA1	22
18.5	74.8	82.3		6KFP23025X4RXCA1	31
22	88	96.8		6KFP23030X4RXCA1	31
30	115	126.5		6KFP23040X4RXCA1	31
37	143	157		6KFP23050X4RXCA1	32
45	170	187		6KFP23060X4RXCA1	32

400V, 3-phase, 50/60Hz input

Nominal motor ratings			Enclosure type ⁽²⁾ :	Cat. No. and Ref. No.	Unit size
Power kW	Current A	Overload current (A) (110% 1 Min)			
0.75	1.3	1.43	IP66 Conformal Coated	6KFP43001X4RXCA1	15
1.5	2.4	2.64		6KFP43002X4RXCA1	15
2.2	4.1	4.51		6KFP43003X4RXCA1	15
4	5.6	6.16		6KFP43005X4RXCA1	15
5.5	10	11		6KFP43007X4RXCA1	15
7.5	13	14.3		6KFP43010X4RXCA1	15
11	16	17.6		6KFP43015X4RXCA1	21
15	32	35.2		6KFP43020X4RXCA1	21
18.5	37.5	41.25		6KFP43025X4RXCA1	21
22	44	48.4		6KFP43030X4RXCA1	22
30	61	67.1		6KFP43040X4RXCA1	22
37	73	80.3		6KFP43050X4RXCA1	31
45	90	99		6KFP43060X4RXCA1	31
55	106	116.6		6KFP43075X4RXCA1	31
75	147	161.7		6KFP43100X4RXCA1	32
90	177	194.7		6KFP43125X4RXCA1	32

(1) Drives are rated IP21 without the need for a separate kit.

(2) IP21 kits are available as field installed options for all 230V drives from 1.1 to 45kW and for all 400V drives from 1.1 to 90kW. See page G.59.

AF-6 drives

Intro

A

B

C

D

E

F

G

H

I

X



Options and accessories

Field installed IP21 add-on option kits

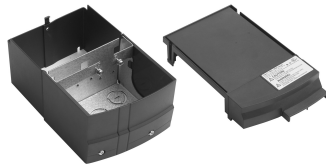

Voltage	Power kW	IP21 kit Cat. No.	Ref. No.
230	0.75	NEMA1ACA2	404831
	1.5	NEMA1ACA2	404831
	2.2	NEMA1ACA2	404831
	3.7	NEMA1ACA3	404832
	5.5	NEMA1ACB3	404833
	7.5	NEMA1ACB3	404833
	11	NEMA1ACB3	404833
	15	NEMA1ACB4	404834
	18.5	NEMA1ACB4	404834
	22	NEMA1ACC3	404835
	30	NEMA1ACC3	404835
	37	NEMA1ACC4	404836
400	45	NEMA1ACC4	404836
	0.75	NEMA1ACA2	404831
	1.5	NEMA1ACA2	404831
	2.2	NEMA1ACA2	404831
	3.7	NEMA1ACA2	404831
	5.5	NEMA1ACA3	404832
	7.5	NEMA1ACA3	404832
	11	NEMA1ACB3	404833
	15	NEMA1ACB3	404833
	18.5	NEMA1ACB3	404833
	22	NEMA1ACB4	404834
	30	NEMA1ACB4	404834
	37	NEMA1ACB4	404834
	45	NEMA1ACC3	404835
	55	NEMA1ACC3	404835
75	NEMA1ACC4	404836	
90	NEMA1ACC4	404836	

Remote mounting kit for graphical LCD keypad



Remote mounting Kit for mounting graphical LCD Keypad on enclosure door. Kit includes gasket, mounting brackets, and cable. Keypad is rated IP65.

Description	Cat. No.	Ref. No.
Remote mounting kit for graphical LCD keypad with cable (3m)	RMKYPDAC	404851
Remote mounting kit without cable	OPCRMKNC	404850

Communications modules



Profibus DP communications module Profibus DP internal drive mounted module for use on AF-650 GP and AF-600 FP drives. Supports Profibus DP V1 communications networks.	OPCPDP	404848
DeviceNet communications module DeviceNet internal drive mounted module for use on AF-650 GP and AF-600 FP drives. ODVA certified device.	OPCDEV	404818
Ethernet IP communications module Ethernet IP internal drive mounted module for use on AF-650 GP and AF-600 FP drives. ODVA certified device. Features 2-port built-in switch. Also includes webserver and e-mail notification.	OPCEIP	404820
Modbus TCP communications module Modbus TCP internal drive mounted module for use on AF-650 GP and AF-600 FP drives.	OPCMBTCP	404824
ProfiNet RT communications module ProfiNet RT internal drive mounted module for use on AF-650 GP and AF-600 FP drives.	OPCPRT	404825
LonWorks communications module LonWorks internal drive mounted module for use on AF-600 FP drives only. Supports LonWorks building automation communications networks.	OPCLON	404823
BacNet communications module BacNet internal drive mounted module for use on AF-600 FP drives only. Supports BacNet MSTP building automation communications networks.	OPCBAC	404817
Profibus SUB-D9 Adapter Profibus SUB-D9 adapter to connect to SUB-D9 connectors and cables in all installed devices.	OPCTERMD9	409562



Options and accessories (continued)



Relay output module

Relay output internal drive mounted module for use on AF-600 drives.
Module adds (3) Form C relay outputs to the drive. Relays are rated at 2A at 240V resistive load.

Description	Cat. No.	Ref. No.
Relay output module	OPCRLY	404849



Analog I/O module

Analog I/O internal drive mounted module for use on AF-600 FP drive only.
Module includes: 3 Analogue inputs 0-10V, 0/4-20mA
3 Analogue outputs 0-10V
Battery back-up power for AF-600 FP's internal real time clock

Analog I/O module	OPCAIO	404816
-------------------	--------	--------



24V DC external supply module

24V DC external supply internal drive mounted module for use on AF-600 FP drives. This module accepts an external 24V DC supply which is used to keep the control board of the drive and other option modules powered in the event of a line side power outage.
Can be used with communications and I/O modules.

24V DC external supply module	OPC24VPS	404815
-------------------------------	----------	--------



General purpose I/O module

General purpose I/O internal drive mounted module for use on AF-600 FP drives.
Module includes: 3x digital inputs 24V
2x digital outputs PNP/NPN
2x analogue inputs 0-10V
1x analogue output 0/4-20mA

General purpose I/O module	OPCGPIO	404821
----------------------------	---------	--------



Screw terminal accessory

Screw terminal accessory is available for field installation on AF-600 FP drives. These screw terminals can replace the cage clamp terminals which ship with each drive. This set of three terminals are for the digital inputs, analog I/O, and RS485 connection.

Screw terminal accessory	OPCSTERM	404822
--------------------------	----------	--------

Intro

A

B

C

D

E

F

G

H

I

X

Options and accessories (continued)

Pedestal kit

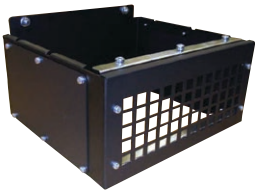

Pedestal kit allows Unit Size 41h and 42h drives to be floor mounted (IP21/54/55, 110 to 250/315kW at 400V for AF-600 FP).

Description	Cat. No.	Ref. No.
Pedestal kit for unit size 41h	OPCPED41H	409506
Pedestal kit for unit size 42h	OPCPED42H	409507

USB kit



This kit allows for the USB programming terminal to be brought out to the front cover of the drive. Works with all drive types.

Description	Cat. No.	Ref. No.
For all drives up to unit size 5X	OPCUSB	404861
For all unit size 6X drives	OPCUSB6X	404860

Power shields

These shields are used to cover the drive power terminals on IP21 and IP54/55 drive types.

For unit size 51 drives	OPCCOVER51	404847
-------------------------	------------	--------



Basic wiring diagrams

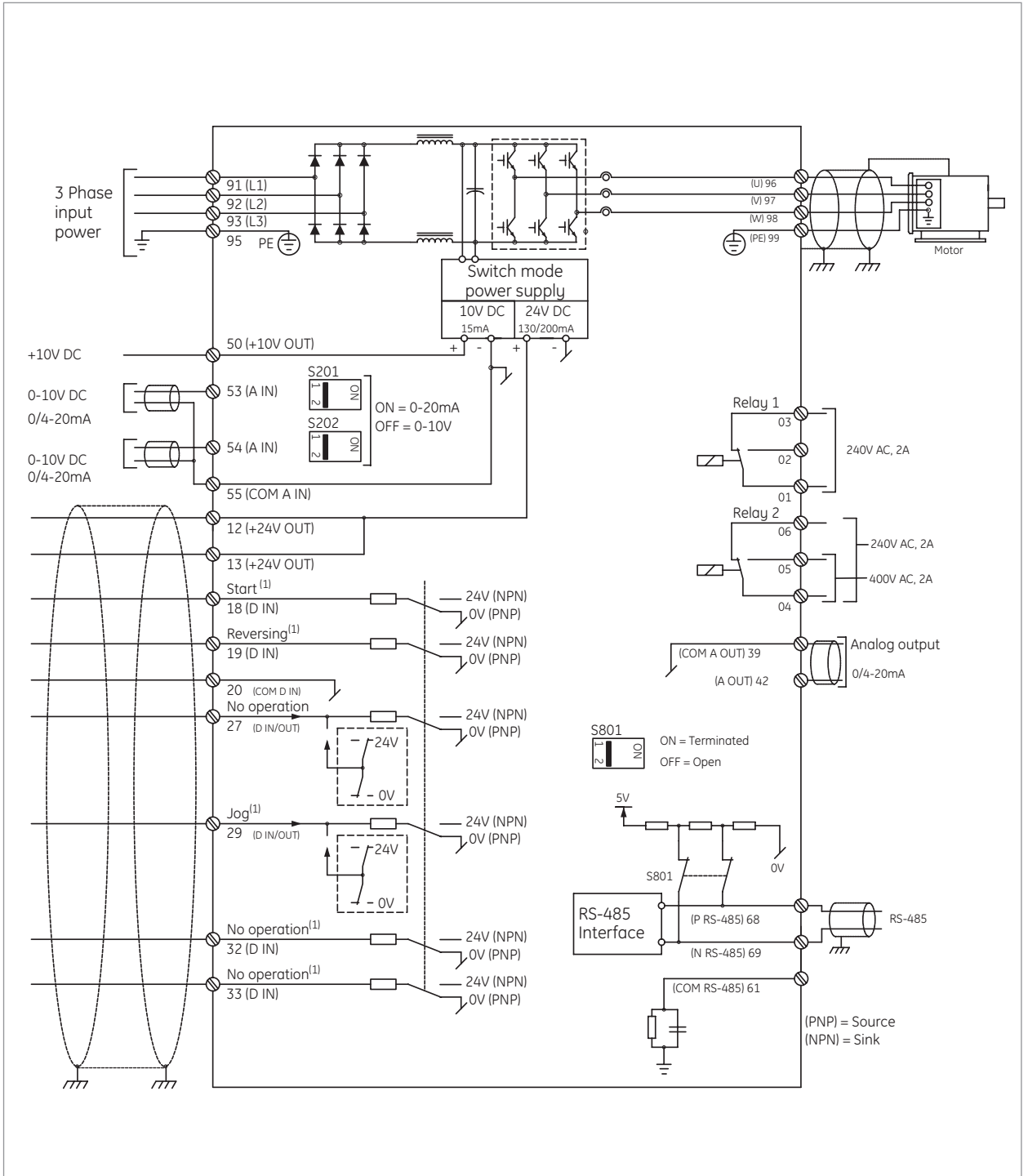

(1) Indicates default setting; see parameter group E-## to re-program.



Specifications

Environmental conditions

Enclosures	IP20 chassis, IP00 chassis, IP21, IP55, IP54
Installation location	For use at altitudes of 1000m or less without derating.
Storage temperature	-25° to 65°C
Ambient temperature	-10° to +50°C for above 45°C, there will be derating; please consult GE
Ambient humidity	5 to 95% RH (non-condensing)
Vibration	1.0 G
Cooling method	Fan cooled all ratings. Fan control auto, 50% level, 75% level, 100% level adjustable

Standards

Approvals	CE, UL, cUL, and C-Tick Suitable for use on a circuit capable of delivering not more than 100,000 rms symmetrical amperes for 230V and 400V.
-----------	---

Input power supply

Rated input AC voltage	200-240 Vac, 3-phase, 50-60 Hz, +/- 10% V 380-480 Vac, 3-phase, 50-60 Hz, +/- 10% V 525-690 Vac, 3-phase, 50-60 Hz, +/- 10% V
Maximum voltage imbalance	3% of rated supply voltage
True power factor	> 0.9 nominal at rated load
Displacement power factor	> 0.98
Switching on input power supply	Maximum twice/minute up to 7.5kW, maximum once/minute above 7.5kW
Environment according to EN60664-1	Overvoltage category III/pollution degree 2
DC link reactors	Built-In DC Link Reactors on all ratings
RFI filters	Built-In RFI Filters to reduce noise generated by the drive.

Output

Rated output voltage	0-100% of supply voltage
Output frequency	0-590 Hz
Switching on output	Unlimited
Accel/decel times	1-3600 seconds
Control method	Sinusoidal PWM control (V/Hz, Avd. vector control)

Control

Starting torque	110% starting torque for 1 minute (variable torque)
Carrier frequency (motor noise)	Selectable - 1, 1.5, 2, 2.5, 3, 3.5, 4, 5, 6, 7, 8, 10, 12, 14, 16 kHz
Torque boost	0 - 300% setting to compensate voltage in relation to the load at low speed
Acceleration/deceleration time	0.01-3600 seconds (4 acceleration and deceleration times are selectable via digital inputs. Acceleration and deceleration patterns can be selected from linear or S-curve)
Data protection	Password protection for quick menu or main menu, 0-9999.
Pattern operation	Settings via built-in logic controller sequencer
Jump frequency control	4 jump (or skip) frequencies via parameter set to avoid mechanical vibration
Slip compensation	Maintains motor at constant speed with load fluctuations
Torque limit control	Output torque can be controlled within a range of 0.0 to 110% (0.1 and steps)
Preset speeds	8 programmable preset speeds selectable by 3 digital inputs
Built-in communications	Drive RS-485, Modbus RTU, Metasys N2, or Apogee FLN P1
Trim reference setting	Available for speed reference offset via potentiometer, voltage input, or current input
DC injection braking	Starting frequency: 0.0-590 Hz, Braking time: 0.0-60.0 seconds, Braking level: 0-100% of rated current
Jogging operation	Operation via on key or digital input (fwd or rev)

Auto-restart after power failure	Restarts the drive without stopping after instantaneous power failure
Energy savings	Controls output voltage to minimize motor loss during constant speed operation
Start mode function	This functionality smoothly catches a spinning motor
Fire override mode	Overrides drive's protective features and keeps motor running
Pump cascade controller	Distributes running hours evenly over up to 4 pumps
Sleep mode	Drive detects low or no flow conditions and adjusts output
Dry pump detection	Detects pump operation and can set off alarm, shuts off, or other programmed actions
Belt monitoring	Drive can detect relationship between current and speed to recognize a broken belt
Real time clock	With programmable timed actions

Logic controller (LC) sequencer

Logic controller events	Up to 38 programmable events
Comparators	Array of 6 comparators
Timers	Array of 8 timers, adjustable from 0.0 to 3600 sec
Logic rules	Array of 6 boolean logic rules
Logic controller states	Array of 20 logic controller action states

Process controller (PID)

Controller	4 auto tune PID controllers built-in
Feedback select	Up to 2 references. Selectable - no function, motor feedback, separate encoder, encoder option module, or resolver option module
Control	Normal or inverse
Anti windup	Disabled or enabled
Start speed	0.0-200 Hz
Proportional gain	0.00-10.00
Integral time	0.1 - 10000.0 ms
Differential time	0.0 - 10 s
Differential gain	1.0-50.00
Feed forward factor	0-500%
On reference bandwidth	0-200%

Operation

Operation method	Keypad operation: hand, off, auto digital input: programmable for start/stop, forward/reverse, jog timer operation: stop after predetermined time frame Communications: RS-485 Modbus RTU, Metasys N2, and Apogee FLN P1 USB port for programming drive with optional PC software
Frequency reference signal	Left or right arrow buttons on keypad in manual mode Speed potentiometer: 0 to +10Vdc, 10 to 0Vdc 0-10Vdc analog input 0/4-20ma analog input
References	Up to 3 Input references can be selected from analogue input #1 or #2, frequency input #1 or #2, network, or potentiometer
Output signals	2x digital outputs 24 Vdc (digital outputs are used in place of 2 of the digital inputs) 2x form C relays rated to 2A at 230 Vac 1x analog output 0/4 to 20mA



Specifications

Protective functions	Line phase loss DC overvoltage DC undervoltage Drive overload Motor overtemperature Motor thermistor overtemperature Torque limit Overcurrent Ground fault Short circuit Control word timeout Brake resistor short-circuited Brake chopper short-circuited Brake check DC Link voltage high DC Link voltage low Internal fan fault External fan fault Power board overtemperature Missing U phase Missing V phase Missing W phase Internal fault Control voltage fault Auto tune check - wrong motor parameters Auto Tune low inom - motor current is too low Current limit Mechanical brake low Drive initialized to default value Keypad error No motor Soft charge fault Auto tuning fault Serial comms bus fault Hardware mismatch Speed limit
-----------------------------	---

Keypad

Keypad features	LCD display with 6 alpha-numeric lines. Multi-language support Hot pluggable, remote mount option, and copy-cat Feature, IP65 rating when remote mounted on enclosure LED's - green - drive is on, yellow - indicates a warning, red - indicates an alarm, amber - indicates active menu keys and H-O-A keys
Password	2 level password protection
Alternate motor parameters	Up to 4 separate complete parameter set-ups are available
Graphical trending	Trend speed, power, frequency

RS485 Modbus RTU serial communications

Physical level	EIA/RS485
Transmission distance	500m
Node address	32
Transmission speed	2400, 4800, 9600, 19200, 38400, or 115200 (bits/s)
Transmission mode	Half Duplex
Transmission protocol	Modbus RTU
Character code	Binary
Character length	8 bits
Error check	CRC

Mounting clearance

	All AF-600 FP drives can be mounted side-by-side without spacing. For all drives rated 90kW or below allow 100mm free space above and below. For all drives rated 110kW and above allow 225mm free space above and below.
--	--



Efficiency, Watt loss, unit size, dimensions and weights

230 Vac, 3-phase, 50/60Hz

Nominal motor ratings		Efficiency			Watt loss (W)	Unit size	Drive type	Height (mm)	Width (mm)	Depth (mm)	Weight (kg)
Power kW	Current A	at 5 kHz (%)	at 4 kHz (%)	at 3 kHz (%)							
0.75	6.6	96			63	12	IP20	375	90	220	5
1.5	7.5	96			82	12		375	90	220	5
2.2	10.6	96			116	12		375	90	220	5
4	16.7	96			185	13		375	90	220	5
5.5	24.2		96		269	23		375	130	220	7
7.5	30.8		96		310	23		375	130	220	7
11	46.2		96		447	23		420	165	262	12
15	59.4		96		602	24		420	165	262	12
18.5	74.8		96		737	24		595	230	242	24
22	88			97	845	33		595	230	242	24
30	115			97	1140	33		595	230	242	24
37	143			97	1353	34		630	308	334	35
45	170			97	1636	34		630	308	334	35

400 Vac, 3-phase, 50/60Hz

Nominal motor ratings		Efficiency				Watt loss (W)	Unit size	Drive type	Height (mm)	Width (mm)	Depth (mm)	Weight (kg)
Power kW	Current A	at 5 kHz (%)	at 4 kHz (%)	at 3 kHz (%)	at 2 kHz (%)							
0.75	2.4	96				58	12	IP20	375	90	220	5
1.5	4.1	97				62	12		375	90	220	5
2.2	5.6	97				88	12		375	90	220	5
4	10	97				124	12		375	90	220	5
5.5	13	97				187	13		375	90	220	5
7.5	16	97				255	13		375	130	220	7
11	24		98			278	23		375	130	220	7
15	32		98			392	23		420	165	262	12
18.5	37.5		98			465	23		420	165	262	12
22	44		98			525	24		595	230	242	24
30	61		98			698	24		595	230	242	24
37	73		98			739	24		595	230	242	24
45	90			98		843	33		630	308	334	35
55	106			98		1083	33		630	308	334	35
75	147			98		1384	34		800	370	334	50
90	177			98		1474	34		800	370	334	50
110	212			98		2559	43h	909	250	35	62	
132	260			98		2954	43h	909	250	35	62	
160	315			98		3770	43h	909	250	35	62	
200	395			98		4116	44h	1122	350	375	125	
250	480			98		5137	44h	1122	350	375	125	
315	600				98	6674	44h	1122	350	375	125	
355	658			98		7532	52	1547	585	497.8	313	
400	745			98		8677	52	1547	585	497.8	313	
450	800			98		9428	52	1547	585	497.8	313	
500	80			98		10162	61	2282	1400	606	1004	
560	990			98		11822	61	2282	1400	606	1004	
630	1120			98		12512	61	2282	1400	606	1004	
710	1260			98		14674	61	2282	1400	606	1004	
800	1460			98		17293	62	2282	1800	606	1262	
1000	1720			98		19278	62	2282	1800	606	1262	



Dimensional drawings

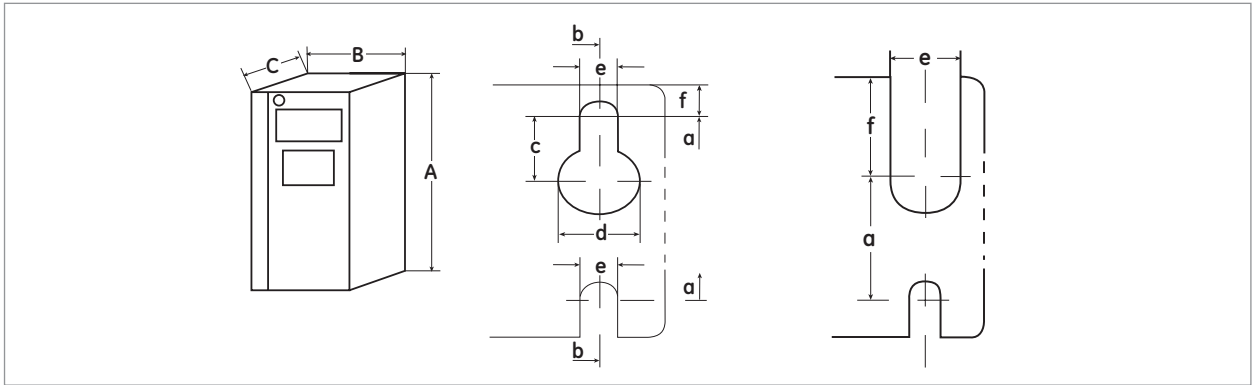

Dimensions, 1X unit sizes (mm)

Unit size		Dimensions	12	13	15
Enclosure type			IP20	IP20	IP55
Voltage	230V		0.75 to 2.2kW 1 to 3HP	3.7kW 5HP	0.75 to 3.7kW 1 to 5HP
	400V		0.75 to 2.2kW 1 to 5HP	5.5 to 7.5kW 7.5 to 10HP	0.75 to 7.5kW 1 to 10HP
Height	Height of backplate	A	268	268	420
	Height with de-coupling plate	A	375	375	
	Distance between mounting holes	a	257	257	402
Width	Width of backplate	B	90	130	242
	Distance between mounting holes	b	70	110	215
Depth	Depth without I/O and/or network option	C	205	205	195
	Depth with I/O and/or network option	C	220	220	195
Screw holes		c	8.0	8.0	8.3
		d	11.0	11.0	12.0
		e	5.5	5.5	6.5
		f	9.0	9.0	9.0
Weight (kg)			4.9	6.6	13.5 / 14.2

Dimensions, 2X unit sizes (mm)

Unit size		Dimensions	21 ⁽¹⁾	22 ⁽¹⁾	23	24
Enclosure type			IP55	IP21/IP55	IP20	IP20
Voltage	230V		5.5 to 11kW 7.5 to 15HP	15kW 20HP	5.5 to 11kW 7.5 to 15HP	15 to 18.5kW 20 to 25HP
	400V		11 to 15kW 15 to 25HP	22 to 30kW 30 to 40HP	11 to 18.5kW 15 to 25HP	22 to 37kW 30 to 50HP
	690V			11 to 30kW 15 to 40HP		
Height	Height of backplate	A	480	650	399	521
	Height with de-coupling plate	A	-	-	420	595
	Distance between mounting holes	a	455	625	380	495
Width	Width of backplate	B	242	242	165	230
	Distance between mounting holes	b	210	210	140	200
Depth	Depth without I/O and/or network option	C	260	260	249	242
	Depth with I/O and/or network option	C	260	260	262	242
Screw holes		c	12.0	12.0	8.0	-
		d	19.0	19.0	12.0	-
		e	9.0	9.0	6.8	8.5
		f	9.0	9.0	7.9	15.0
Weight (kg)			23.0	27.0	12.0	23.5

(1) IP55/IP66 units need to have cable glands according table on page G.48 (Cable entry overview)

Dimensions in mm (inch = mm x 0.03937) - Weight in kg (lb = kg x 2.2046)



Dimensional drawings

Dimensions, 3X unit sizes (mm)

Unit size		Dimensions	31 ⁽²⁾	32 ⁽²⁾	33	34
Enclosure type			IP55	IP21/IP55	IP20	IP20
Voltage	230V		18.5 to 30kW 25 to 40HP	37 to 45kW 50 to 60HP	Open chassis 22 to 30kW 30 to 40HP	Open chassis 37 to 45kW 50 to 60HP
	400V		37 to 55kW 50 to 75HP	75 to 90kW 100 to 125HP	45 to 55kW 60 to 75HP	75 to 90kW 100 to 125HP
	690V			37 to 90kW 50 to 125HP		
Height	Height of backplate	A	680	770	550	660
	Height with de-coupling plate	A	-	-	630	800
	Distance between mounting holes	a	648	739	521	631
Width	Width of backplate	B	308	370	308	370
	Distance between mounting holes	b	272	334	270	330
Depth	Depth without I/O and/or network option	C	310	335	333	333
	Depth with I/O and/or network option	C	310	335	333	333
Screw holes		c	12.5	12.5	-	-
		d	19.0	19.0	-	-
		e	9.0	9.0	8.5	8.5
		f	9.8	9.8	17.0	17.0
Weight (kg)			45	65	35	50

Dimensions IP20 open chassis drives with field installed IP21 kits⁽¹⁾ (mm)

Unit size		12	13	23	24	33	34
Enclosure type		IP20 open chassis with IP21 Kit					
Voltage	230V	0.75 to 2.2kW 1 to 3HP	3.7kW 5HP	5.5 to 11kW 7.5 to 15HP	15 to 18.5kW 20 to 25HP	22 to 30kW 30 to 40HP	37 to 45kW 50 to 60HP
	400V	0.75 to 2.2kW 1 to 5HP	5.5 to 7.5kW 7.5 to 10HP	11 to 18.5kW 15 to 25HP	22 to 37kW 30 to 50HP	45 to 55kW 60 to 75HP	75 to 90kW 100 to 125HP
Height	Height with kit	375	375	475	671	754	950
Width	Width of backplate	94	130	165	231	397	371
	Distance between mounting holes	70	110	140	201	269	330
Depth	Depth without I/O and/or network option	205	205	249	242	338	338
	Depth with I/O and/or network option	220	220	262	242	338	338

(1) Please consult IP21 kit instructions for further mounting details and dimensions.

(2) IP55/IP66 units need to have cable glands according table on page G.48 (Cable entry overview)

Note: Please allow 5cm between drives with field installed IP21 kits. Also, please consult the relevant AF-6 Series drives operating Instructions for recommended clearance above and below each drive rating.

Dimensions in mm (inch = mm x 0.03937) - Weight in kg (lb = kg x 2.2046)



Dimensional drawings in mm (inches)

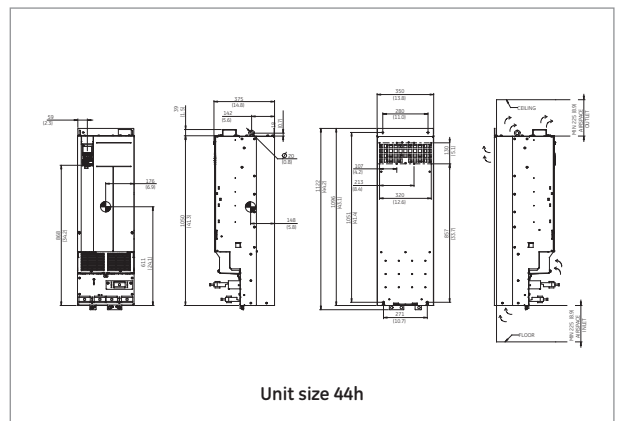
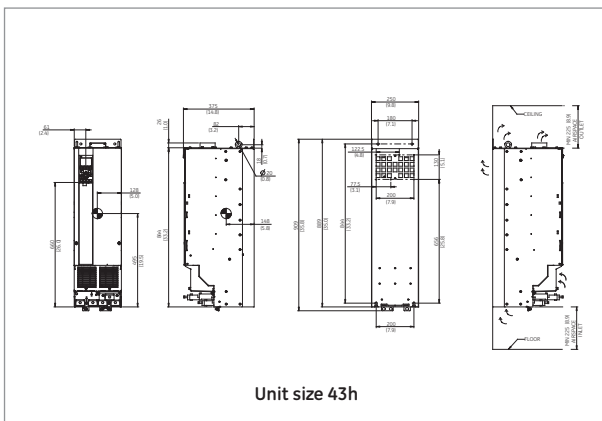
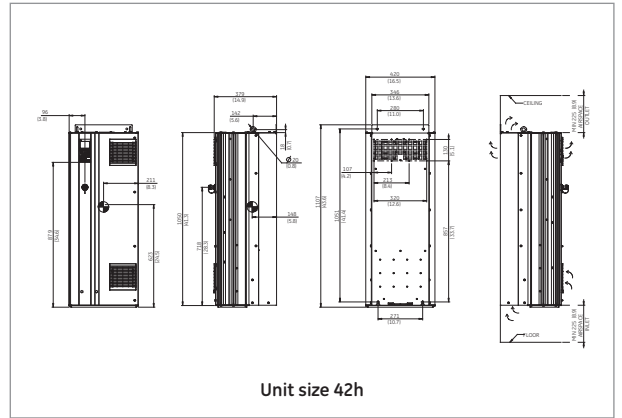
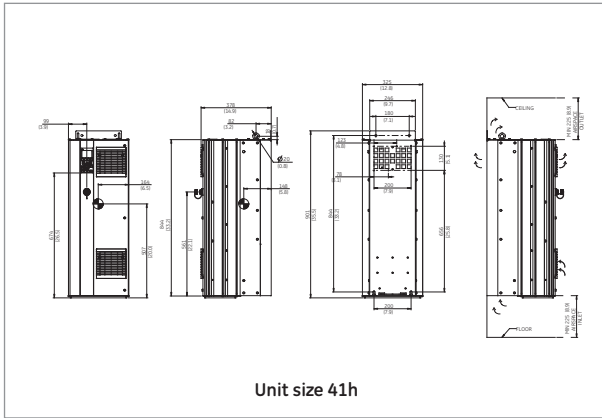

Unit size		41h	42h	43h	44h
Enclosure type		IP21/IP54	IP21/IP54	IP20	IP20
Voltage	400V	110 to 160kW 150 to 250HP	200 to 315kW 300 to 450HP	110 to 160kW 125 to 250HP	200 to 315kW 300 to 450HP
	690V	90 to 132kW 125 to 200HP	160 to 315kW 250 to 450HP	90 to 132kW 125 to 200HP	160 to 315kW 250 to 450HP
Shipping dimensions	Height	590	590	590	590
	Width	1000	1170	1000	1170
	Depth	460	535	460	535
Drive dimensions	Height	901	1107	909	1122
	Width	325	420	250	350
	Depth	378	379	375	375
Weight (kg)		98	164	98	164

Dimensions in mm (inch = mm x 0.03937) - Weight in kg (lb = kg x 2.2046)



Dimensional drawings in mm (inches)

Unit size 62

Unit size 62

Enclosure type	IP21/IP55
Voltage 400V	800 to 1000kW 1200 to 1350HP
Voltage 690V	1000 to 1400kW 1350 to 1900HP
Shipping Dimensions	
Height	2324
Width	2159
Depth	927
Drive Dimensions	
Height	2282
Width	2000
Depth	606
Weight (kg)	1300

Unit size 63

Unit size 63 (with options)

Enclosure type	IP21/IP55
Voltage 400V	500 to 710kW 650 to 1000HP
Voltage 690V	710 to 900kW 1000 to 1250HP
Shipping dimensions	
Height	2324
Width	1961
Depth	419
Drive dimensions	
Height	2282
Width	1800
Depth	606
Weight (kg)	1262

Unit size 64

Unit size 64 (with options)

Enclosure type	IP21/IP55
Voltage 400V	800 to 1000kW 1200 to 1350HP
Voltage 690V	1000 to 1400kW 1350 to 1900HP
Shipping dimensions	
Height	2324
Width	2543
Depth	927
Drive dimensions	
Height	2282
Width	2400
Depth	606
Weight (kg)	1541

Dimensions in mm (inch = mm x 0.03937) - Weight in kg (lb = kg x 2.2046)



Everything is under control

Braking resistors

Designed to be used with high inertia loads which need to be stopped rapidly.
Used to dissipate energy that is transferred back from the motor during regeneration.

230 Vac

Output rated power		Drive Brake Chopper	5% Duty Cycle		Cat. No.	Ref. No.
kW	HP		Resistance (Ohms)	Power continuous (W)		
0.37	0.5	N/A				
0.75	1	N/A				
1.5	2	Built-in	100	200	7KLPBR100P200	168812
2.2	3	Built-in	100	200	7KLPBR100P200	168812
4	5	Built-in	100	200	7KLPBR100P200	168812
5.5	7.5	Built-in	100	200	7KLPBR100P200	168812
7.5	10	Built-in	33	300	7KLPBR033P300	168814
11	15	Built-in	33	300	7KLPBR033P300	168814

400 Vac

Output rated power		Drive Brake Chopper	5% Duty Cycle		Cat. No.	Ref. No.
kW	HP		Resistance (Ohms)	Power continuous (W)		
0.75	1	N/A	100	200	-	-
1.5	2	Built-in	100	200	7KLPBR100P200	168812
2.2	3	Built-in	100	200	7KLPBR100P200	168812
4	5	Built-in	100	200	7KLPBR100P200	168812
5.5	7.5	Built-in	100	200	7KLPBR100P200	168812
7.5	10	Built-in	100	200	7KLPBR100P200	168812
11	15	Built-in	33	300	7KLPBR033P300	168814
15	20	Built-in	33	300	7KLPBR033P300	168814
18.5	25	Built-in	33	300	7KLPBR033P300	168814
22	30	Built-in	100	200	7KLPBR100P200	168812



External EMC (RFI) Filter

IP20, 1-phase input

Output rated power		Description	Cat. No.	Ref. No.	Unit Size
kW	HP				
0.75	1	EMC Filter, 1 Phase, 10 A, IP20	7KEMC1010	168815	2
1.5	2	EMC Filter, 1 Phase, 25 A, IP20	7KEMC1025	168816	2
2.2	3	EMC Filter, 1 Phase, 25 A, IP20	7KEMC1025	168816	2

IP20, 3-phase input

Output rated power		Description	Cat. No.	Ref. No.	Unit Size
kW	HP				
0.75	1	EMC Filter, 3 Phase, 6 A, IP20	7KEMC3006	168817	2
1.5	2	EMC Filter, 3 Phase, 16 A, IP20	7KEMC3016	168818	2
2.2	3	EMC Filter, 3 Phase, 16 A, IP20	7KEMC3016	168818	2
4	5	EMC Filter, 3 Phase, 16 A, IP20	7KEMC3016	168818	2
4	5	EMC Filter, 3 Phase, 25 A, IP20	7KEMC3025	168819	3
5.5	7.5	EMC Filter, 3 Phase, 25 A, IP20	7KEMC3025	168819	3
7.5	10	EMC Filter, 3 Phase, 25 A, IP20	7KEMC3025	168819	3
11	15	EMC Filter, 3 Phase, 25 A, IP20	7KEMC3025	168819	3
7.5	10	EMC Filter, 3 Phase, 50 A, IP20	7KEMC3050	168820	4
11	15	EMC Filter, 3 Phase, 50 A, IP20	7KEMC3050	168820	4
15	20	EMC Filter, 3 Phase, 50 A, IP20	7KEMC3050	168820	4
18.5	25	EMC Filter, 3 Phase, 50 A, IP20	7KEMC3050	168820	4
22	30	EMC Filter, 3 Phase, 50 A, IP20	7KEMC3050	168820	4
30	40	EMC Filter, 3 Phase, 80 A, IP20	7KEMC3080	168821	5
37	50	EMC Filter, 3 Phase, 80 A, IP20	7KEMC3080	168821	5
45	60	EMC Filter, 3 Phase, 180 A, IP20	7KEMC3180	168822	5
45	60	EMC Filter, 3 Phase, 180 A, IP20	7KEMC3180	168822	6
55	75	EMC Filter, 3 Phase, 180 A, IP20	7KEMC3180	168822	6
75	100	EMC Filter, 3 Phase, 180 A, IP20	7KEMC3180	168822	6
90	125	EMC Filter, 3 Phase, 180 A, IP20	7KEMC3180	168822	6
110	150	EMC Filter, 3 Phase, 300 A, IP00	7KEMC3300	168823	7
132	200	EMC Filter, 3 Phase, 300 A, IP00	7KEMC3300	168823	7
160	250	EMC Filter, 3 Phase, 300 A, IP00	7KEMC3300	168823	7
200	300	EMC Filter, 3 Phase, 500 A, IP00	7KEMC3500	168829	8
250	350	EMC Filter, 3 Phase, 500 A, IP00	7KEMC3500	168829	8

IP66, 1-phase input

Output rated power		Description	Cat. No.	Ref. No.	Unit Size
kW	HP				
0.75	1	EMC Filter, 1 Phase, 10 A, IP66	7KEMC1010X4	168824	2
1.5	2	EMC Filter, 1 Phase, 25 A, IP66	7KEMC1025X4	169001	2
2.2	3	EMC Filter, 1 Phase, 25 A, IP66	7KEMC1025X4	169001	2

IP66, 3-phase input

Output rated power		Description	Cat. No.	Ref. No.	Unit Size
kW	HP				
0.75	1	EMC Filter, 3 Phase, 6 A, IP66	7KEMC3006X4	168826	2
1.5	2	EMC Filter, 3 Phase, 16 A, IP66	7KEMC3016X4	168827	2
2.2	3	EMC Filter, 3 Phase, 16 A, IP66	7KEMC3016X4	168827	2
4	5	EMC Filter, 3 Phase, 16 A, IP66	7KEMC3016X4	168827	2
5.5	7.5	EMC Filter, 3 Phase, 25 A, IP66	7KEMC3025X4	168828	3
7.5	10	EMC Filter, 3 Phase, 25 A, IP66	7KEMC3025X4	168828	3
11	15	EMC Filter, 3 Phase, 25 A, IP66	7KEMC3025X4	168828	3



External EMC (RFI) Filter

IP20, 1-phase input

Output rated power		Description	Cat. No.	Ref. No.	Unit Size
kW	HP				
0.37	0.5	EMC Filter, 1 Phase, 10 A, IP20	7KEMC1010	168815	1
0.75	1	EMC Filter, 1 Phase, 10 A, IP20	7KEMC1010	168815	1
1.5	2	EMC Filter, 1 Phase, 25 A, IP20	7KEMC1025	168816	1
1.5	2	EMC Filter, 1 Phase, 25 A, IP20	7KEMC1025	168816	2
2.2	3	EMC Filter, 1 Phase, 25 A, IP20	7KEMC1025	168816	2

IP20, 3-phase input

Output rated power		Description	Cat. No.	Ref. No.	Unit Size
kW	HP				
0.37	0.5	EMC Filter, 3 Phase, 6 A, IP20	7KEMC3006	168817	1
0.75	1	EMC Filter, 3 Phase, 6 A, IP20	7KEMC3006	168817	1
1.5	2	EMC Filter, 3 Phase, 6 A, IP20	7KEMC3006	168817	1
1.5	2	EMC Filter, 3 Phase, 16 A, IP20	7KEMC3016	168818	2
2.2	3	EMC Filter, 3 Phase, 16 A, IP20	7KEMC3016	168818	2
4	5	EMC Filter, 3 Phase, 16 A, IP20	7KEMC3016	168818	2
4	5	EMC Filter, 3 Phase, 25 A, IP20	7KEMC3025	168819	3
5.5	7.5	EMC Filter, 3 Phase, 25 A, IP20	7KEMC3025	168819	3
7.5	10	EMC Filter, 3 Phase, 25 A, IP20	7KEMC3025	168819	3
11	15	EMC Filter, 3 Phase, 25 A, IP20	7KEMC3025	168819	3
7.5	10	EMC Filter, 3 Phase, 50 A, IP20	7KEMC3050	168820	4
11	15	EMC Filter, 3 Phase, 50 A, IP20	7KEMC3050	168820	4
15	20	EMC Filter, 3 Phase, 50 A, IP20	7KEMC3050	168820	4
18.5	25	EMC Filter, 3 Phase, 50 A, IP20	7KEMC3050	168820	4
22	30	EMC Filter, 3 Phase, 50 A, IP20	7KEMC3050	168820	4

IP66, 1-phase input

Output rated power		Description	Cat. No.	Ref. No.	Unit Size
kW	HP				
0.37	0.5	EMC Filter, 1 Phase, 10 A, IP66	7KEMC1010X4	168824	1
0.75	1	EMC Filter, 1 Phase, 10 A, IP66	7KEMC1010X4	168824	1
1.5	2	EMC Filter, 1 Phase, 10 A, IP66	7KEMC1010X4	168824	1
1.5	2	EMC Filter, 1 Phase, 25 A, IP66	7KEMC1025X4	169001	2
2.2	3	EMC Filter, 1 Phase, 25 A, IP66	7KEMC1025X4	169001	2

IP66, 3-phase input

Output rated power		Description	Cat. No.	Ref. No.	Unit Size
kW	HP				
0.37	0.5	EMC Filter, 3 Phase, 6 A, IP66	7KEMC3006X4	168826	1
0.75	1	EMC Filter, 3 Phase, 6 A, IP66	7KEMC3006X4	168826	1
1.5	2	EMC Filter, 3 Phase, 6 A, IP66	7KEMC3006X4	168826	1
1.5	2	EMC Filter, 3 Phase, 16 A, IP66	7KEMC3016X4	168827	2
2.2	3	EMC Filter, 3 Phase, 16 A, IP66	7KEMC3016X4	168827	2
4	5	EMC Filter, 3 Phase, 16 A, IP66	7KEMC3016X4	168827	2
4	5	EMC Filter, 3 Phase, 25 A, IP66	7KEMC3025X4	168828	3
5.5	7.5	EMC Filter, 3 Phase, 25 A, IP66	7KEMC3025X4	168828	3
7.5	10	EMC Filter, 3 Phase, 25 A, IP66	7KEMC3025X4	168828	3

AF-7 drives

Intro

A

B

C

D

E

F

G

New



Dimensional drawings

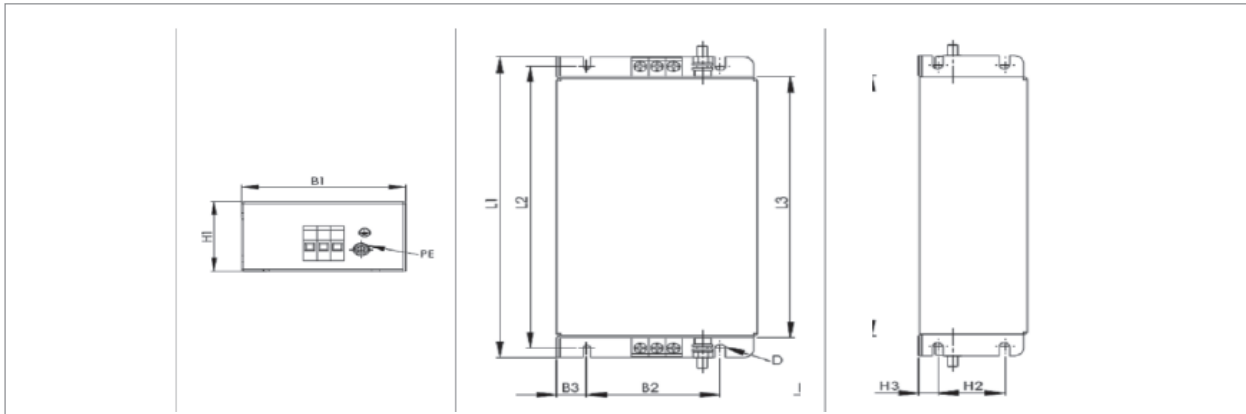

Cat. No.	Ref. No.	Description	PE Connection	Dimensions in mm										Weight (kg)
				L1	L2	L3	B1	B2	B3	H1	H2	H3	D	
7KEMC1010	168815	EMC Filter, 1 Phase, 10 A, IP20	2 x M6	180	166	150	70	45	12.5	65	40	12.5	6.2	1.5
7KEMC1025	168816	EMC Filter, 1 Phase, 10 A, IP20	2 x M6	250	236	220	70	45	12.5	65	40	12.5	6.2	2.8
7KEMC3006	168817	EMC Filter, 3 Phase, 6 A, IP20	2.5	210	169	180	85	55	15	60	40	10	6.2	2.7
7KEMC3016	168818	EMC Filter, 3 Phase, 16 A, IP20	2.5	230	216	200	120	80	20	65	40	12.5	6.2	2.7
7KEMC3025	168819	EMC Filter, 3 Phase, 25 A, IP20	2.5	230	216	200	120	80	20	65	40	12.5	6.2	2.7

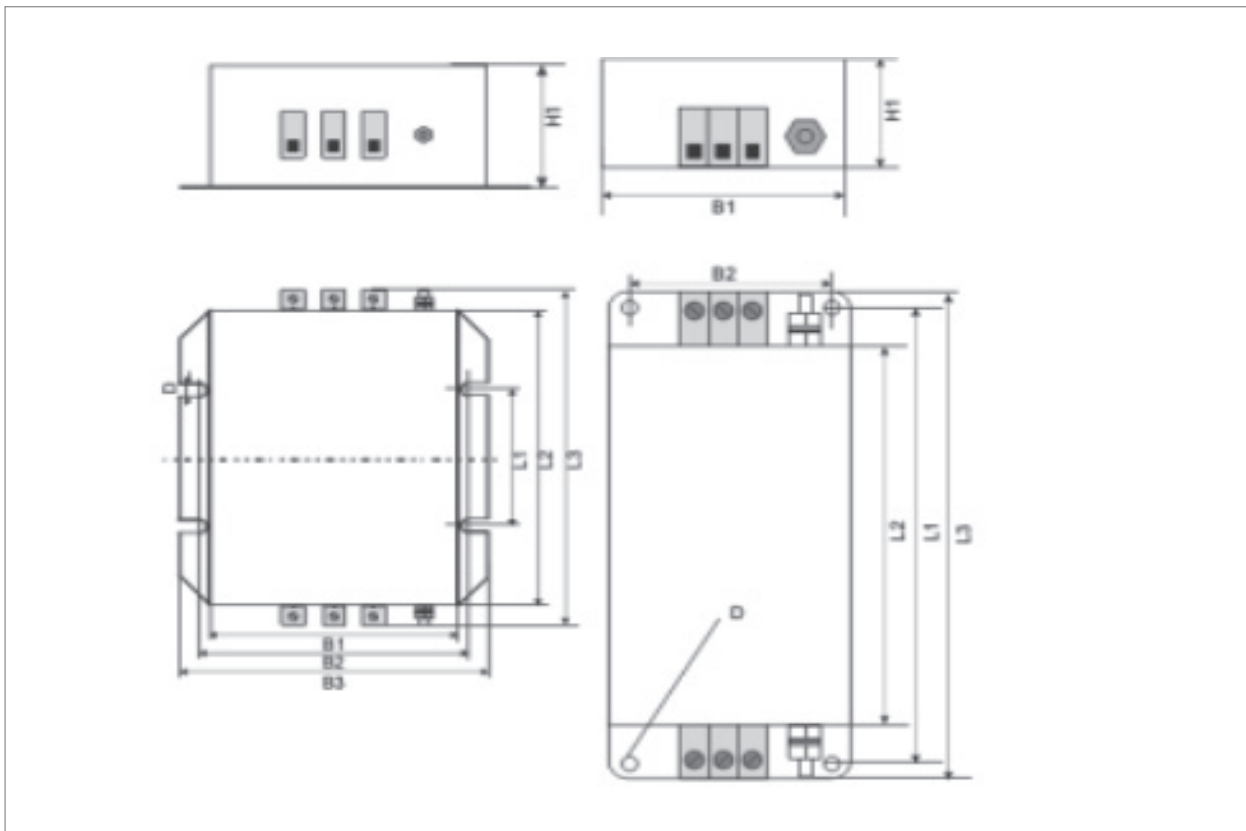

Cat. No.	Ref. No.	Description	PE Connection	Dimensions in mm										Weight (kg)
				L1	L2	L3	B1	B2	B3	H1	D			
7KEMC3050	168820	EMC Filter, 3 Phase, 50 A, IP20	2 x M6	115	200	240	120	136	150	65	6.5	4.5		

Dimensions in mm (inch = mm x 0.03937) - Weight in kg (lb = kg x 2.2046)



Options & Accessories

Dimensional drawings

External EMC Filters

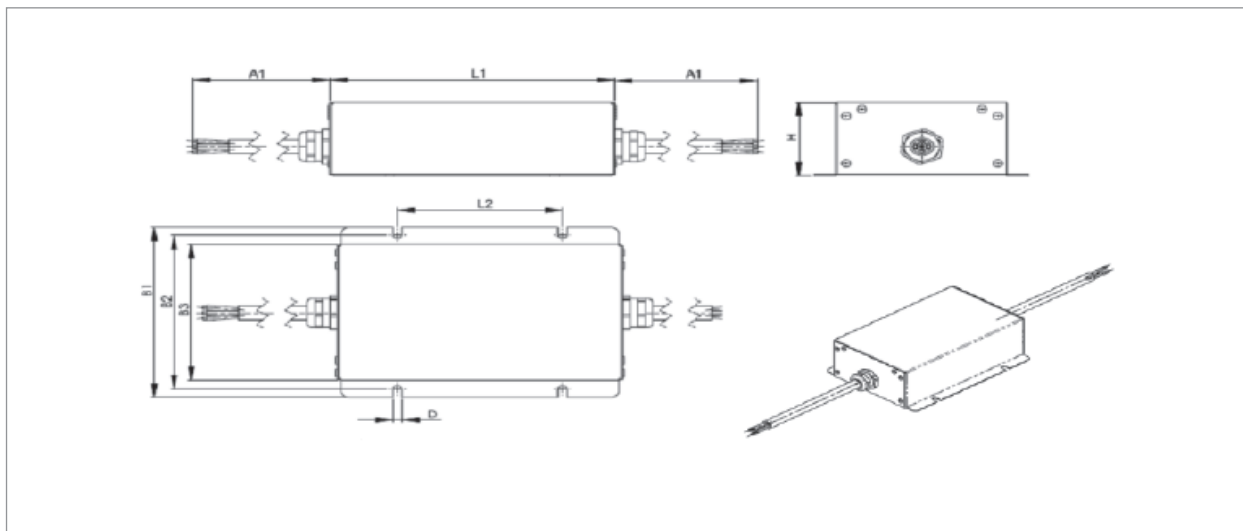

Cat. No.	Ref. No.	Description	PE Connection	Dimensions in mm								
				L1	L2	L3	B1	B2	B3	H1	D	A1
7KEMC1010X4	168824	EMC Filter, 1 Phase, 10 A, IP66	2 x M6	180	166	150	70	45	12.5	65		
7KEMC1025X4	168825	EMC Filter, 1 Phase, 25 A, IP66	2 x M6	250	236	220	70	45	12.5	65		
7KEMC3006X4	168826	EMC Filter, 3 Phase, 6 A, IP66	2.5	210	196	180	85	55	15	60	6.2	500
7KEMC3016X4	168827	EMC Filter, 3 Phase, 16 A, IP66	2.5	230	216	200	120	80	20	65		
7KEMC3025X4	168828	EMC Filter, 3 Phase, 25 A, IP66	2.5	200	115	-	150	136	120	65		

Braking resistor

Cat. No.	Ref. No.	Description	Dimensions in mm		
			Height (mm)	Length (mm)	Depth (mm)
7KLPBR100P200	168812	Braking Resistor,100R,200W	40	188	9
7KLPBR033P300	168814	Brake Resistor,33R,300W	80	330	10

Dimensions in mm (inch = mm x 0.03937) - Weight in kg (lb = kg x 2.2046)



Dimensional drawings

External EMC filters

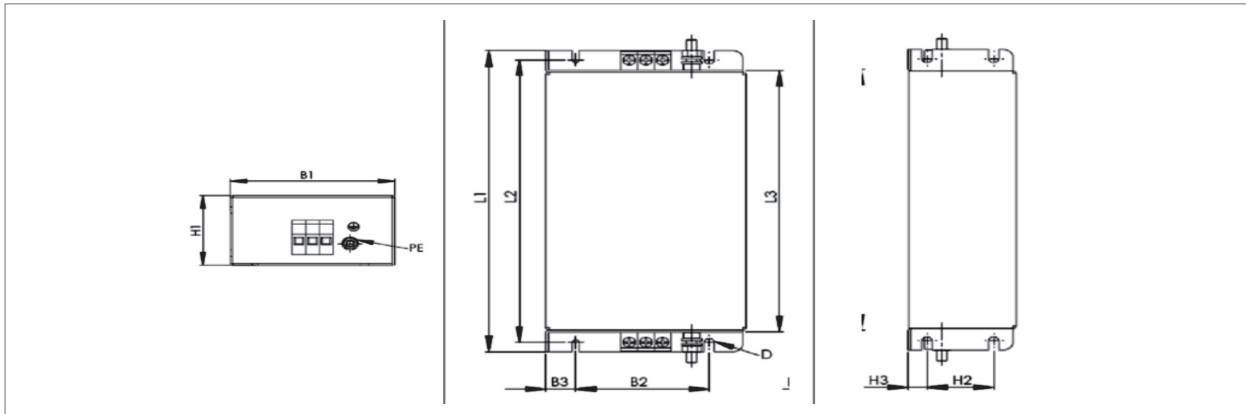

Cat. No.	Ref. No.	Description	PE Connection	Dimensions in mm										Weight (kg)
				L1	L2	L3	B1	B2	B3	H1	H2	H3	D	
7KEMC1010	168815	EMC Filter, 1 Phase, 10 A, IP20	2 x M6	180	166	150	70	45	12.5	65	40	12.5	6.2	1.5
7KEMC1025	168816	EMC Filter, 1 Phase, 10 A, IP20	2 x M6	250	236	220	70	45	12.5	65	40	12.5	6.2	2.8
7KEMC3006	168817	EMC Filter, 3 Phase, 6 A, IP20	2.5	210	169	180	85	55	15	60	40	10	6.2	2.7
7KEMC3016	168818	EMC Filter, 3 Phase, 16 A, IP20	2.5	230	216	200	120	80	20	65	40	12.5	6.2	2.7
7KEMC3025	168819	EMC Filter, 3 Phase, 25 A, IP20	2.5	230	216	200	120	80	20	65	40	12.5	6.2	2.7

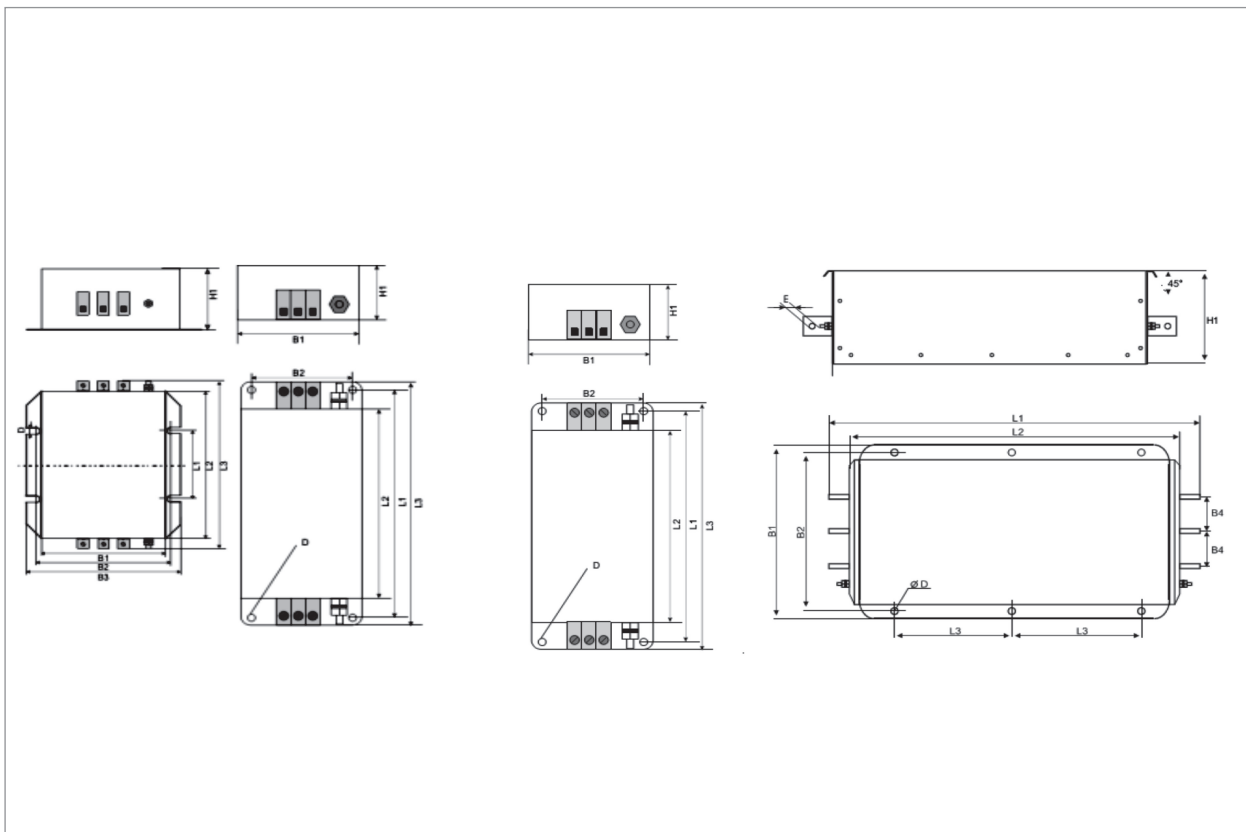

Cat. No.	Ref. No.	Description	PE Connection	Dimensions in mm										Weight (kg)
				L1	L2	L3	B1	B2	B3	H1	D			
7KEMC3050	168820	EMC Filter, 3 Phase, 50 A, IP20	2 x M6	115	200	240	120	136	150	65	6.5	6.5	4.5	
7KEMC3080	168821	EMC Filter, 3 Phase, 80 A, IP20	2 x M10	373	350	400	170	130	-	65	6.5	5		
7KEMC3180	168822	EMC Filter, 3 Phase, 180 A, IP20	2 x M10	470	360	510	180	156	-	115	9	7.2		
7KEMC3300	168823	EMC Filter, 3 Phase, 300 A, IP00	2 x M10	660	530	700	260	220	-	130	9	10		
7KEMC3500	168829	EMC Filter, 3 Phase, 500 A, IP00	2 x M12	390	306	-	260	235	-	135	11	12		

Dimensions in mm (inch = mm x 0.03937) - Weight in kg (lb = kg x 2.2046)

Options & Accessories

Dimensional drawings

External EMC filters

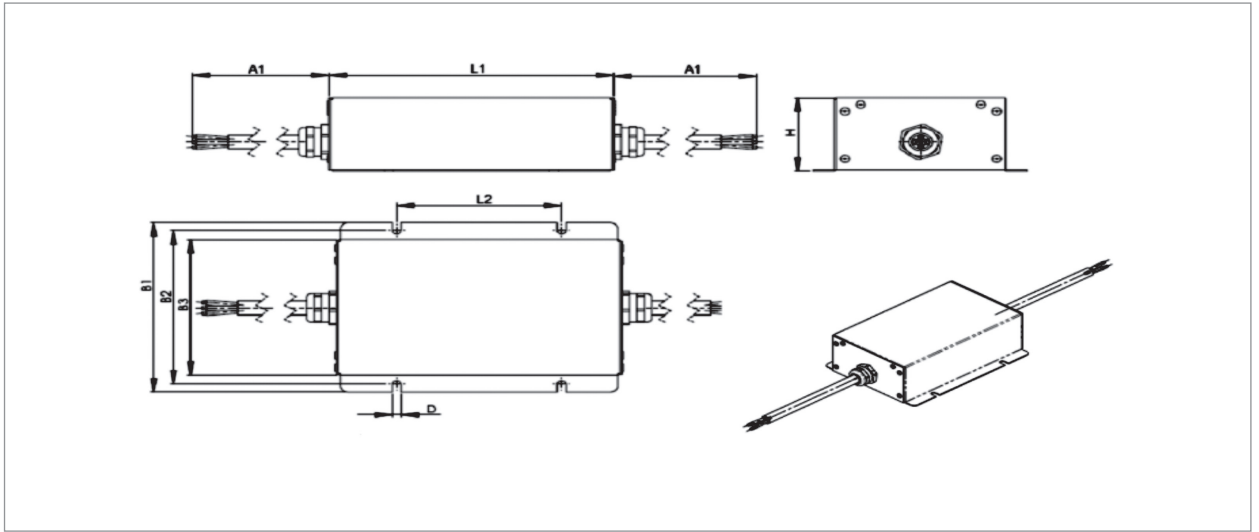

Cat. No.	Ref. No.	Description	PE Connection	Dimensions in mm								D	A1
				L1	L2	L3	B1	B2	B3	H1			
7KEMC1010X4	168824	EMC Filter, 1 Phase, 10 A, IP66	2 x M6	180	166	150	70	45	12.5	65	6.2	500	
7KEMC1025X4	169001	EMC Filter, 1 Phase, 25 A, IP66	2 x M6	250	236	220	70	45	12.5	65			
7KEMC3006X4	168826	EMC Filter, 3 Phase, 6 A, IP66	2.5	210	196	180	85	55	15	60			
7KEMC3016X4	168827	EMC Filter, 3 Phase, 16 A, IP66	2.5	230	216	200	120	80	20	65			
7KEMC3025X4	168828	EMC Filter, 3 Phase, 25 A, IP66	2.5	200	115	-	150	136	120	65			

AF-6 drives

Intro

A

B

C

D

E

F

G

New

Dimensions in mm (inch = mm x 0.03937) - Weight in kg (lb = kg x 2.2046)



Dynamic Braking Resistors

Dynamic braking allows for faster deceleration rates than could be achieved via a coast to stop. Dynamic braking consists of the internal drive brake chopper and separate add-on dynamic braking resistors.

Important application notes:

- The AF-60 LP Micro Drive dynamic braking can be used for stopping a load with an inertia equal to or less than the applied motor's rotor inertia.
- High inertia or overhauling loads may cause extended deceleration times which could cause overheating and tripping of the drive.
- The dynamic braking is not a holding brake. It does not prevent a motor at rest from rotating.

Note: refer to the drives' Operating Instruction for installation and connection details.

Dynamic braking resistors- AF-60 LP drives

230 Vac

Nominal applied motor kW	Nominal applied motor HP	Max. braking torque (%)	Brake chopper	Recommended dynamic braking resistor				Total Ohms	Total kW	
				10% duty cycle		40% duty cycle			10% duty cycle	40% duty cycle
				Cat. No.	Ref. No.	Cat. No.	Ref. No.			
0.18	1/4	-	N/A	-	-	-	-	-	-	
0.37	1/2	-	N/A	-	-	-	-	-	-	
0.75	1	-	N/A	-	-	-	-	-	-	
1.5	2	150	Built-in	TLR74P200	129870	4 x TLR74P200	4 x 129870	74	0.2	0.8
2.2	3	150	Built-in	TLR44P600	129166	TLR43P1000	129177	44	0.6	1
3.7	5	150	Built-in	TLR29P600	129167	TLR22P2500	129879	29	0.6	2.5

400 Vac

Nominal applied motor kW	Nominal applied motor HP	Max. braking torque (%)	Brake chopper	Recommended dynamic braking resistor				Total Ohms	Total kW	
				10% duty cycle		40% duty cycle			10% duty cycle	40% duty cycle
				Cat. No.	Ref. No.	Cat. No.	Ref. No.			
0.37	1/2	-	N/A	-	-	-	-	-	-	
0.75	1	-	N/A	-	-	-	-	-	-	
1.5	2	150	Built-in	TLR295P200	129876	4 x TLR295P200	4 x 129876	295	0.2	0.8
2.2	3	150	Built-in	TLR216P200	129868	4 x TLR216P200	4 x 129868	216	0.2	0.8
4	5	150	Built-in	TLR118P600	129174	4 x TLR118P600	4 x 129174	118	0.6	2.4
5.5	8	150	Built-in	TLR86P600	129175	4 x TLR86P600	4 x 129175	86	0.6	2.4
7.5	10	150	Built-in	TLR59P1000	129176	4 x TLR59P1000	4 x 129176	59	1	4
11	15	150	Built-in	TLR43P1000	129177			43	1	-
15	20	150	Built-in	TLR35P1500	129877			35	1.5	-
18.5	25	150	Built-in	TLR29P1800	129878	On request		29	1.8	-
22	30	150	Built-in	TLR22P2500	129879			22	2.5	-



Options & Accessories

Dynamic braking resistors - AF-650 GP drives

230 Vac

Nominal applied motor kW	Nominal applied motor HP	Max. braking torque (%)	Repetitive braking torque duty - 10%					Repetitive braking torque duty - 40%				
			(kW)	Ohms	Cont. max breaking time(s)	Cat. No.	Ref. No.	(kW)	Ohms	Cont. max breaking time(s)	Cat. No.	Ref. No.
0.25	1/3	160	0.2	405	12	TLR405P200	129867	0.43	425	120	TLR405P200	129867
0.37	1/2	160	0.2	295	12	TLR295P200	129876	0.80	310	120	4 x TLR295P200	4 x 129876
0.75	1	160	0.6	118	12	TLR118P600	129174	0.26	145	120	TLR118P600	129174
1.5	2	160	1	59	12	TLR59P1000	129176	0.80	65	120	TLR59P1000	129176
2.2	3	160	1	43	12	TLR43P1000	129177	1.00	50	120	TLR43P1000	129177
3.7	5	160	1.8	29	12	TLR29P1800	129878	3.00	25	120	TLR22P2500	129879
5.5	7.5	158	2.5	22	12	TLR22P2500	129879	-	-	-	-	-
7.5	10	153	3	17.6	12	2 x TLR8,8P1500	2 x 129171	-	-	-	-	-
11	15	154	5	10	12	2 x TLR5P2500	2 x 129871	-	-	-	-	-
15	20	150	6	8	12	2 x TLR4P3000	2 x 129872	-	-	-	-	-
18.5	25	150	6	8	12	2 x TLR4P3000	2 x 129872	-	-	-	-	-
22	30	150	6	4.7	30			-	-	-	-	-
30	40	150	8	3.3	30			-	-	-	-	-
37	50	150	10	2.7	30		On request	-	-	-	-	-

400 Vac

Nominal applied motor kW	Nominal applied motor HP	Max. braking torque (%)	Repetitive braking torque duty - 10%					Repetitive braking torque duty - 40%				
			(kW)	Ohms	Cont. max breaking time(s)	Cat. No.	Ref. No.	(kW)	Ohms	Cont. max breaking time(s)	Cat. No.	Ref. No.
0.37	0.5	160	0.2	750	12	TLR750P200	116301	0.2	620	120	TLR750P200	116301
0.75	1	160	0.2	750	12	TLR750P200	116301	0.2	620	120	TLR750P200	116301
1.5	2	160	0.2	295	12	TLR295P200	129876	0.4	310	120	2 x TLR750P200	2 x 116301
2.2	3	160	0.2	216	12	TLR216P200	129868	0.4	210	120	2 x TLR432P200	2 x 129875
4	5	160	0.6	118	12	TLR118P600	129174	2	110	120	2 x TLR59P1000	2 x 129176
5.5	7.5	160	0.6	86	12	TLR86P600	129175	3	80	120	2 x TLR35P1500	2 x 129877
7.5	10	160	1	59	12	TLR59P1000	129176	6	65	120	2 x TLR35P3000	2 x 129888
11	15	160	1	43	12	TLR43P1000	129177	5	40	120	2 x TLR22P2500	2 x 129879
15	20	160	1.5	35	12	TLR35P1500	129877	7.4	30	120	2 x TLR15P3700	2 x 129881
18.5	25	160	1.8	29	12	TLR29P1800	129878	10	25	120	4 x TLR22P2500	4 x 129879
22	30	160	2.5	22	12	TLR22P2500	129879	10	20	120	4 x TLR22P2500	4 x 129879
30	40	150	3.7	15	12	TLR15P3700	129881	14.8	15	120	4 x TLR15P3700	4 x 129881
37	50	150	4.7	12.5	12							
45	60	150	6.4	9.2	12							
55	75	150	7.7	4.3	12							
75	100	150	13.6	4.3	12							
90	125	150	17	3.4	30							
110	150	150	17	3.4	30							
132	200	150	22.5	10.4	30							
160	250	150	27.2	8.6	30							
200	300	150	17	3.3	30							
250	350	150	22.4	10.4	30							
355	450	150	27.2	8.6	30							
400	550	150	14.4	1.3	30							
450	600	150	14.4	1.3	30							
500	650	150	14.4	1.3	30							
560	750	150	14.4	1.3	30							
630	900	150	14.4	1.3	30							
710	1000	150	14.4	1.3	30							
800	1200	150	14.4	1.3	30							

AF Drives

Intro

A

B

C

D

E

F

G

H

I

X



	Description	Cat. no	Ref. no	Pack
Braking resistors 100% braking torque, 10% ED	-	TLR100P200	108223	1
	-	TLR75P200	116300	1
	-	TLR750P200	116301	1
	-	TLR400P200	116302	1
	-	TLR250P200	108227	1

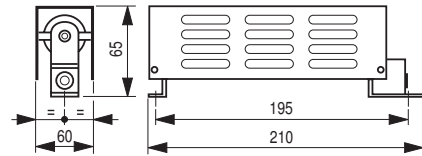

	Description	Losses (W)	Cat. no	Ref. no	Pack
Reactors	Input reactors for single phase drives				
		2.5	ACRP3A7H0	168490	-
		5	ACRP8A2H5	168491	-
		7	ACRP12A2H5	168492	-
		7.5	ACRP18A1H3	168493	-
		8	ACRP22A0H84	168494	-
	Input reactors for three phase drives				
		11	ACRP6A2H5	168496	-
		14	ACRP9A1H3	168497	-
		8	ACRP3A8H1	168509	-
	9	ACRP4A5H1	168510	-	
	11	ACRP6A3H4	168511	-	

Cat.No.	Losses W	Fig.	A	B	C	D	E	Ø	Weight (kg)
ACRP3A7H0	2.4	4	75	96	85	80	56	6	1.3
ACRP8A2H5	5.2	4	75	96	100	80	56	6	1.8
ACRP12A2H5	6.8	4	84	102	110	86	65	6	2.7
ACRP18A1H3	7.3	4	96	112	106	96	77	6	3.2
ACRP22A0H84	8	4	96	112	116	96	77	6	3.7
ACRP6A2H5	17	1	120	80	152	41	100	6	1.5
ACRP9A1H3	18	1	120	80	152	41	100	6	1.6
ACRP3A8H1	17	1	120	80	152	41	100	6	1.4
ACRP4A5H1	16	1	120	80	152	41	100	6	1.5
ACRP6A3H4	19	1	120	80	152	41	100	6	1.7

Fig. 4

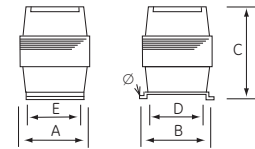
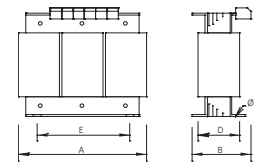

Fig. 1



Dimensions in mm



AC input reactors

Fig. 1

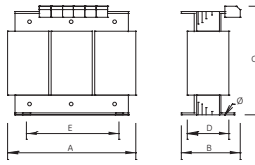

Fig. 3

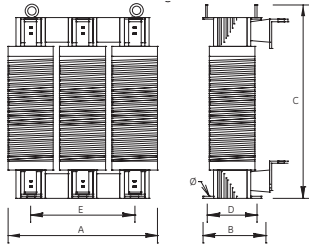
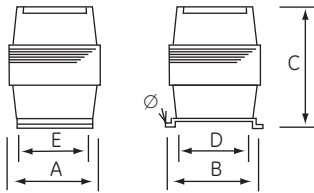

Fig. 4



Cat. No.	Ref.No.	Losses W	Fig.	Dimensions (mm)					Weight (kg)	
				A	B	C	D	E		Ø
ACRP8A2H5	168491	5.2	4	75	96	100	80	56	6	1.8
ACRP12A2H5	168492	6.8	4	84	102	110	86	65	6	2.7
ACRP18A1H3	168493	7.3	4	96	112	106	96	77	6	3.2
ACRP22A0H84	168494	8	4	96	112	116	96	77	6	3.7
ACRP4A2H5	168495	16	1	120	80	152	41	100	6	1.3
ACRP6A2H5	168496	18	1	120	80	152	41	100	6	1.5
ACRP9A1H3	168497	17	1	120	80	152	41	100	6	1.6
ACRP12A0H84	168498	18	1	120	80	152	41	100	6	1.7
ACRP18A0H56	168499	21	1	120	90	152	51	100	6	2.4
ACRP27A0H37	168500	32	1	150	95	183	46	125	6	3.3
ACRP35A0H27	168501	35	1	150	95	183	46	125	6	3.7
ACRP3A8H1	168509	17	1	120	80	152	41	100	6	1.4
ACRP4A5H1	168510	16	1	120	80	152	41	100	6	1.5
ACRP6A3H4	168511	19	1	120	80	152	41	100	6	1.7
ACRP10A2H	168512	23	1	120	90	152	51	100	6	2.5
ACRP14A1H4	168513	29	1	150	95	178	46	125	6	3.2
ACRP18A1H1	168514	35	1	150	95	178	46	125	6	4
ACRP27A0H75	168515	77	1	150	106	233	72	100	9	4.8
ACRP35A0H58	168516	98	1	150	111	233	77	100	9	5.5
ACRP38A0H58	168517	96	1	150	116	233	82	100	9	6.4
ACRP45A0H45	168518	102	1	150	121	233	87	100	9	7.1
ACRP70A0H29	168519	147	1	150	151	250	117	100	9	11
ACRP90A0H22	168520	158	1	180	136	286	102	120	9	13.1
ACRP115A0H18	168521	186	1	180	156	301	122	120	9	16.9
ACRP160A0H14	168522	268	3	240	181	288	107	160	9	25.7

Dimensions in mm (inch = mm x 0.03937) - Weight in kg (lb = kg x 2.2046)



- H.2 Introduction
- H.4 Short overview
- H.5 Application guide
- H.7 Catalogue number structure
- H.8 Specifications
- H.10 Soft Start Methods
- H.13 Order codes
- H.18 Technical data
- H.22 Features
- H.28 Accessories

POWER DEVICES

Contactors and overload relays

Auxiliary relays and contactors

Motor protection devices

Applications

AUXILIARY DEVICES

Main switches

Control and signalling units

POWER ELECTRONICS

Speed drive units

Soft starters

ENCLOSURES

Product overview

Alphabetical index

Intro

A

B

C

D

E

F

G

H

I

X



Welcome to the new digital soft starters!
GE ASTAT family

ASTAT XB and XBm

Soft starters

The GE ASTAT family of Low Voltage Soft Starters is pleased to welcome the new **XB** and **XBm** series in the power range from 18 to 200A, 7.5 to 110kW at 400V AC, 10 to 150HP at 460V AC, with a wide voltage range of 200 to 575V AC

Perfect for applications like Pump, Fans, Compressors, Conveyors,...

These new series are compact and cost effective soft starter solution, simple operation, with a built-in bypass function and conformal coated as standard. Easy DIN-rail mounting for sizes up to 60A, 30kW/50HP at 460V AC, 2-wire or 3-wire start/stop control and excellent starting duty (4 x In for 6 seconds). Heavy starting ratings at 4x In for 20 seconds. Compatible with grounded delta power systems.

The ASTAT XBm is a Constant Current system with current measurement and control. It provides a range of motor protection functions in addition to soft start and soft stop. Protections include motor overload, phase loss and excess start time, along with a programmable relay.

Features:

- ✓ Compact design
- ✓ Built-in bypass
- ✓ Friendly use
- ✓ Conformal coated PCBs (3C2)
- ✓ DIN-rail mounting up to 30kW at 400V AC, 50HP at 460V AC
- ✓ Motor protections (XBm series)
- ✓ Remote operator kit available as option



ASTAT XL

New digital soft starter **XL** series in the power range from 23 to 1600A, 11 to 800kW at 400V AC, 15 to 1200HP at 460V AC, with a wide voltage range of 200 to 690V AC

Perfect for applications like Pump, Fans, Compressors, Conveyors, Mixers, Mills, Centrifuges,...

These new series has an intuitive user-friendly keypad, with four-line multi-language text (8 languages: English, German, French, Spanish, Portuguese, Italian, Chinese and Russian), Real-time graphs of motor operating performance and 3 types of Setup menus: Standard, Extended and Quick. It can record the last 8 trips, up to 99 events log.

The ASTAT XL is a Constant Current and Current Ramp but also able to control acceleration. According to your application, you can select between early, constant or late acceleration/deceleration.



Features:

- ✓ Compact design
- ✓ Built-in bypass (up to 1000A)
- ✓ User friendly programming and feedback
- ✓ Conformal coated PCBs (3C2)
- ✓ Automatically detects in-line or inside delta connection
- ✓ Adjustable busbars for both top and bottom entry above 360A, 200kW at 400V AC, 300HP at 460V AC
- ✓ Motor protections
- ✓ DC injection braking distributed over the 3 phases



Short overview

Soft starters

Series ASTAT	XB	XBm	XL
Starting functions			
Timed Voltage Ramp	✓		
Current Limit		✓	✓
Current Ramp		✓	✓
Kick Start			✓
Adaptative Control			✓
Stopping			
Coast to stop	✓	✓	✓
Timed Voltage Ramp	✓	✓	✓
Adaptative Control			✓
Protection			
Excess Start time		✓	✓
Phase loss		✓	✓
Phase sequence		✓	✓
Current imbalance		✓	✓
Instantaneous overcurrent		✓	✓
Undercurrent			✓
Motor overload		✓	✓
Motor thermistor		✓	✓
Bypass overload		✓	✓
Power Circuit fault	✓	✓	✓
Supply frequency	✓	✓	✓
Communications failure	✓	✓	✓
Interface			
Fixed relay (main contactor)	✓	✓	✓
Programmable relay (Trip or Run)		✓	✓
Run relay	✓		✓
Accessories			
Remote operator	✓	✓	✓
Modbus RTU interface	✓	✓	✓
Modbus TCP/IP interface	✓	✓	✓
Profibus interface	✓	✓	✓
Profinet interface	✓	✓	✓
Ethernet/IP interface	✓	✓	✓
DeviceNet interface	✓	✓	✓
USB interface	✓	✓	✓
IP20 Terminal protection kit (above 140A)	✓	✓	✓
IP20 Terminal protection kit (from 255 to 1000A)			✓
ASTAT Select tool ed.1 (free download)	✓	✓	✓
ASTAT Setup tool ed.3 (free download)	✓	✓	✓

Legend = AVAILABLE = NOT AVAILABLE



What is your application?

Use the table below to select a soft starter based on typical start current and time requirements for your application.

NOTE

Soft starter settings depend on the details of the individual installation (including the characteristics of the starter, motor and load).

APPLICATION	300%, 10 seconds	350%, 15 seconds	400%, 20 seconds	450%, 30 seconds
	LIGHT DUTY	NORMAL DUTY	HEAVY DUTY	SEVERE DUTY
Bow thruster			✓	
Centrifuge				✓
Chipper				✓
Compressor				
centrifugal		✓		
reciprocating - loaded				✓
reciprocating - unloaded			✓	
screw - loaded			✓	
screw - unloaded		✓		
Conveyor				
horizontal		✓		
inclined			✓	
vertical (bucket)				✓
Crusher				
cone		✓		
jaw				✓
rotary			✓	
Debarker			✓	
Fan				
blower/axial (damped)			✓	
blower/axial (undamped)				✓
centrifugal (damped)		✓		
centrifugal (undamped)				✓
high pressure				✓
Mill				
ball				✓
hammer				✓
Pump				
bore	✓			
centrifugal		✓		
positive displacement			✓	
submersible		✓		
Saw				
bandsaw (headrig)				✓
circular (slabber, edger)		✓		
Shredder				✓

WARNING

This selection guide assumes typical motor and operating conditions. Consult your supplier for applications with:

- High start frequency
- High altitude installations (i.e. > 1000 m)
- High ambient installations (i.e. > 40°C)
- Soft stop times exceeding 30 seconds



Everything is under control

Catalogue number structure

ASTAT XB and XBm

Example: Model QS11B018XA1

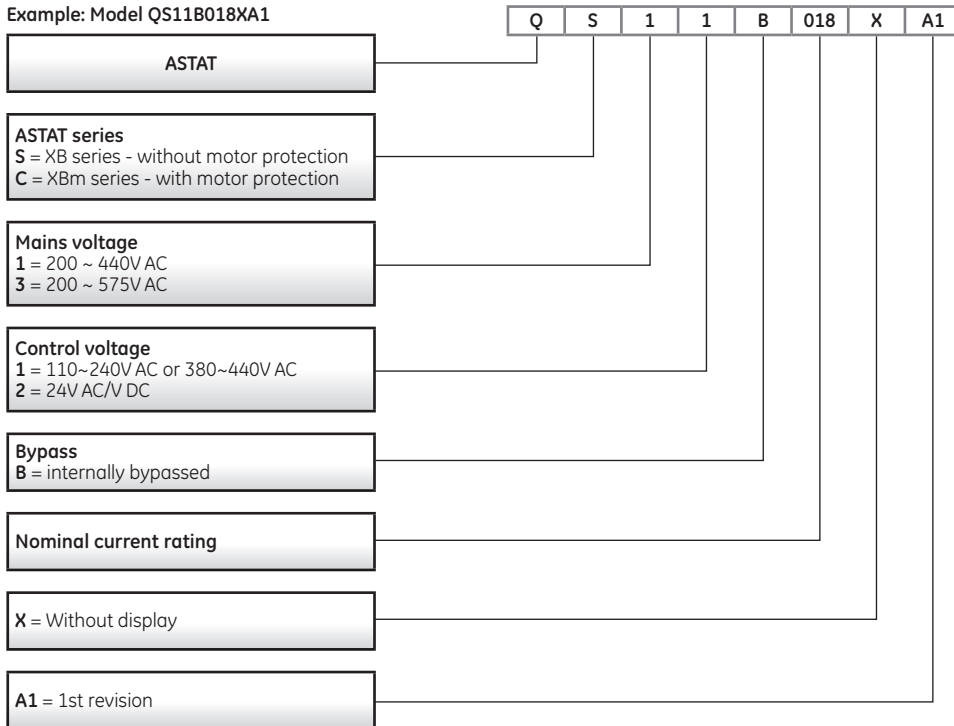

Current Ratings

Unit Size	
18A	1
34A	
42A	
48A	
60A	2
75A	
85A	
100A	3
140A	
170A	
200A	

AC53b 4.0-6:354
AC53b 4.0-6:394

ASTAT XL

Example: Model QL21B023DA1

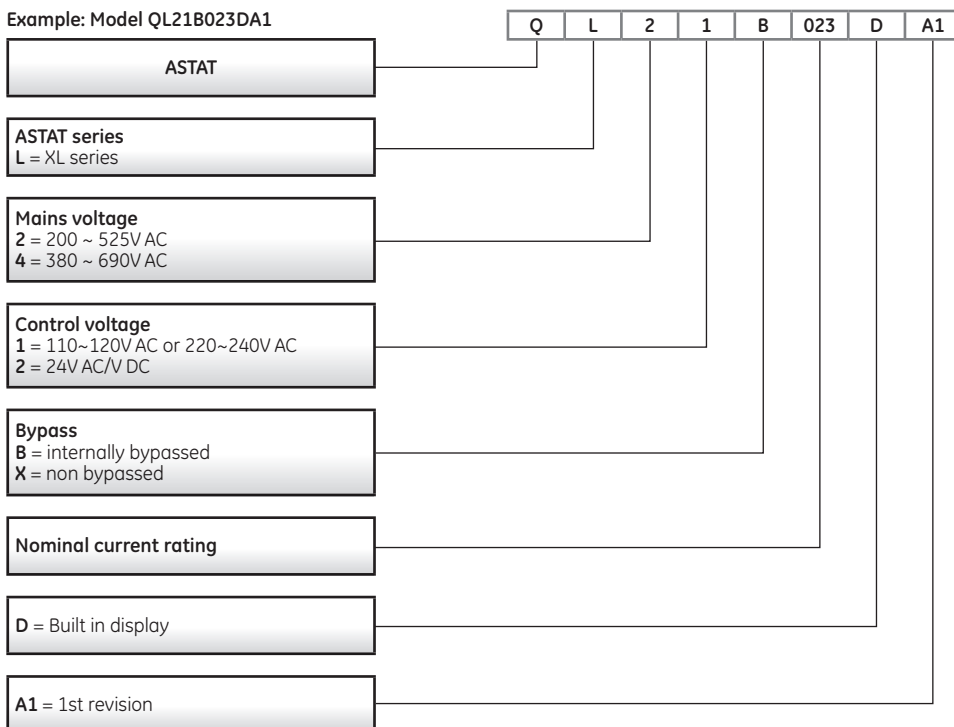

Current Ratings

		Bypassed	Non bypassed
18	23A	-	-
	43A	-	-
	50A	-	-
	53A	-	-
	76A	-	-
	97A	-	-
	100A	-	-
28	105A	-	-
	145A	-	-
	170A	-	-
	200A	-	-
	220A	-	-
38	255A	3C	255A
	350A	-	360A
	425A	-	380A
	500A	-	430A
48	580A	4C	620A
	700A	-	650A
	820A	-	790A
	920A	-	930A
	1000A	-	1200A
	-	5C	1410A
	-	-	1600A



ASTAT XB - XBm - XL

Specifications

Series	XB - XBm	XL
Rated current range		
	18 to 200A	23 to 1600A
Motor connection	In-line	In-line or Inside delta
Bypass	Internal	Internal, from 23 to 1000A External, from 255 to 1600A
Supply		
Mains frequency	45 Hz to 66Hz	45Hz to 66Hz
Rated insulation voltage	600V AC	600V AC
Mains Voltage (A1, A2, A3)		
XB series: QS1_B__XA1	3 x 200V AC ~ 440V AC (+ 10%/-15%)	-
XBm series: QC1_B__XA1		
XB series: QS3_B__XA1	3 x 200V AC ~ 575V AC (+ 10%/-15%)	-
XBm series: QC3_B__XA1		
XL series: QL2_B/X__DA1	-	3 x 200V AC ~ 525V AC (± 10%)
	-	3 x 380V AC ~ 600V AC (± 10%) (in-line or inside delta connection)
XL series: QL4_B/X__DA1	-	3 x 380V AC ~ 690V AC (±10%) (earthed star supply system only)
Control Voltage (A1, A2, A3)		
XB series: QS_1B__XA1	110 ~ 240V AC (+ 10% / -15%)	-
XBm series: QC_1B__XA1	or 380 ~ 440V AC (+ 10% / -15%)	-
XB series: QS_2B__XA1	24V AC AC/24V DC (+ 20%)	-
XBm series: QC_2B__XA1		
XL series: QL_1B/X__DA1	-	110 ~ 240V AC (+ 10% / -15%), 600mA
XL series: QL_2B/X__DA1	-	24V AC AC/24V DC (+ 20%), 2,8A
Current consumption (during run)	< 100mA	-
CURRENT CONSUMPTION (INRUSH)		
QSx1xxxxXA1	10A	-
QSx2xxxxXA1	2A	-
Inputs		
Input rating	-	Active 24V DC, 8mA approx
Start (terminal 01)	NO, 150 kOhm at 300V AC max and 5,6 kOhm at 24V AC/DC	-
Start (terminal 54, 55)	-	NO
Stop (terminal 02)	NO, 150 kOhm at 300V AC max and 5,6 kOhm at 24V AC/DC	-
Stop (terminal 56, 57)	-	NC
Reset (terminal 58, 57)	-	NC
Programmable input (terminal 53, 55)	-	NO
Motor Thermistor (B4, B5) (ASTAT XBm only)	-	-
Motor Thermistor (terminal 64, 65)	-	Trip > 3.6kOhm, reset < 1.6kOhm
Relay Outputs	-	10A at 250V AC resistive, 5A at 250V AC AC15 pf 0.3
Main Contactor (13, 14)	NO	-
	6A, 30V DC resistive / 2A, 400V AC, AC11	-
ASTAT XB - Run relay	NO	-
ASTAT XBm - Programmable relay (23, 24)	NO	-
	6A, 30V DC resistive / 2A, 400 VAC, AC11	-
Programmable Outputs		
Relay A (terminal 13, 14)	-	NO
Relay B (terminal 21, 22, 24)	-	CO
Relay C (terminal 33, 34)	-	NO
Analog output (terminal 40, 41)	-	0-20mA or 4-20mA (selectable)
Maximum load	-	600W (12V DC at 20mA)
Accuracy	-	± 5%
24V DC output (terminal 55, 41)	-	-
Maximum load	-	200mA
Accuracy	-	± 10%



Series	XB - XBm	XL
Environmental		
IP20	18 to 100A	23 to 105A
IP00	140 to 200A	145 to 1600A
Operating temperature	-10 °C, max 60 °C, above 40°C with derating	
Storage temperature	-25 °C to +60 °C	
Operating altitude	0 - 1000m, above 1000m with derating	
Humidity	5% to 95% Relative Humidity	
Pollution degree	Degree 3	
Vibration	IEC 60068 Test Fc Sinusoidal 4Hz to 13,2Hz: ± 1mm displacement 13,2Hz to 200Hz: ± 0,7 g	
Conformal Coating	Standard (3C2)	
Electromagnetic Capability (Compliant With EU Directive 89/336/EEC)		
EMC Emission	IEC 60947-4-2 Class B and Lloyds Marine No 1 Specification	
Equipment class (EMC)	Class B	
Conducted radio frequency emission	0,15MHz to 0,5MHz: < 56 - 46dB (µV), 0,5MHz to 5MHz: < 46 dB (µV), 5MHz to 30MHz: < 50dB (µV)	
Radiated radio frequency emission	30 MHz to 230 MHz: < 30 dB (µV/m), 230 MHz to 1000 MHz: < 37dB (µV/m)	
EMC Immunity	IEC 60947-4-2	
Electrostatic discharge	4kV contact discharge, 8kV air discharge	-
Radio frequency electromagnetic field	0,15MHz to 1000MHz: 140 dB (µV)	-
Rated impulse withstand voltage (fast transients 5/50 ns)	2kV line to earth, 1kV line to line	-
Voltage dip and short time interruption	100ms (at 40% nominal voltage)	-
Harmonics and distortion	IEC 61000-2-4 (Class 3), EN/IEC 61800-3	
Short Circuit Capability		
Rated short circuit current XB, XBm: 18 to 48A	5ka (1)	-
Rated short circuit current XB, XBm: 60 to 200A	10ka (1)	-
(1) These short circuit ratings are with fuses used as given in the table under Semiconductor fuses	-	
Coordination with semiconductor fuses	-	Type 2
Coordination with HRC fuses	-	Type 1
QLxxB023D ~ QLxxB220D	-	prospective current 65kA
QLxxB255D ~ QLxxB1K0D	-	prospective current 85kA
QLxxX255D ~ QLxxX930D	-	prospective current 85kA
QLxxX1K2D ~ QLxxX1K6D	-	prospective current 100kA
Heat Dissipation		
During Start	3W/Ampere	4.5W/Ampere
During Run	10W typical	-
QLxxB023D ~ QLxxB053D	-	≤ 39W approx.
QLxxB076D ~ QLxxB105D	-	≤ 51W approx.
QLxxB145D ~ QLxxB220D	-	≤ 120W approx.
QLxxB255D ~ QLxxB500D	-	≤ 140W approx.
QLxxB580D ~ QLxxB1K0D	-	≤ 357W approx.
QLxxX255D ~ QLxxX1K6D	-	4.5W/ampere approx.
UL certification		
IMPORTANT: ADDITIONAL REQUIREMENTS AND CONFIGURATION SETTINGS FOR ASTAT XL TO BE UL-COMPLIANT		
See also UL Fuse selection and Short Circuit ratings		
QLxxB023D ~ QLxxB105D	-	No additional requirement
QLxxB145D ~ QLxxB220D	-	Use finger guard kit, QOFPROTXL2, 872395 Use the recommended pressure terminal/connector kit
QLxxB255D ~ QLxxB425D	-	Use finger guard kit, QOFPROTXL3, 872396 Use the recommended pressure terminal/connector kit
QLxxX255D	-	Use the recommended pressure terminal/connector kit
QLxxX360D ~ QLxxX1K6D	-	Configure the busbar for line / load terminals at opposite ends of ASTAT XL (i.e. Top In, Bottom Out or Top Out, Bottom In) Use the recommended pressure terminal/connector kit
QLxxB500D ~ QLxxB1K0D	-	These models are UL recognised components. Separate cable landing busbars may be required within the electrical cabinet when terminating cables sized according to the National Wiring Code (NEC) regulations



Soft Start Methods

Balanced Vector Control

In the past soft starters using 2 phase control caused extra heating in the motor and required higher starting currents because the output waveform was not symmetrical.

ASTAT XB and XBm soft starters control only two phases, but include balanced vector control technology that balances the output waveform to make it symmetrical. By balancing the waveform the ASTAT XB and XBm provides 3 phase like performance with compact soft starter technology.

This eliminates previous limitations of 2 phase controllers such as:

- Limited starts per hour
- Limited to light loads only
- Limited to motor < 55kW at 400V AC, 75HP at 460V AC

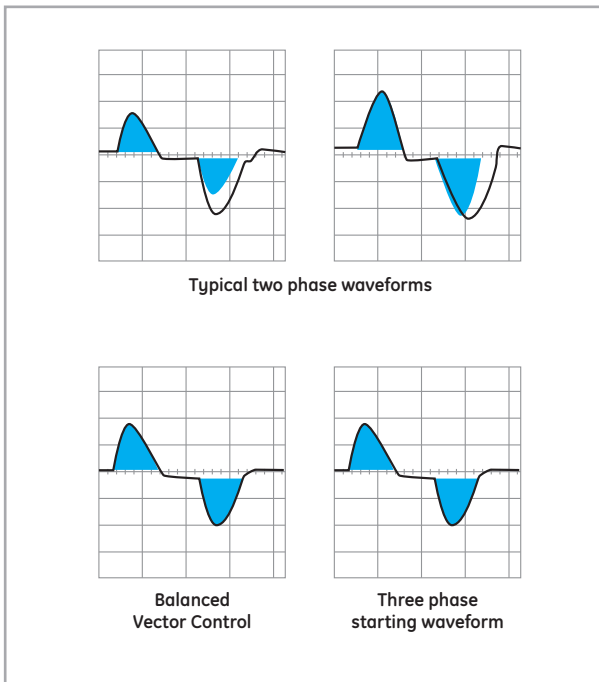

Start methods

Voltage Ramp (ASTAT XB)

Voltage ramp soft starting raises the voltage from a specified starting level (1) to full voltage over an extended period of time (2).

Voltage ramp starting is the simplest way to influence start current and torque.

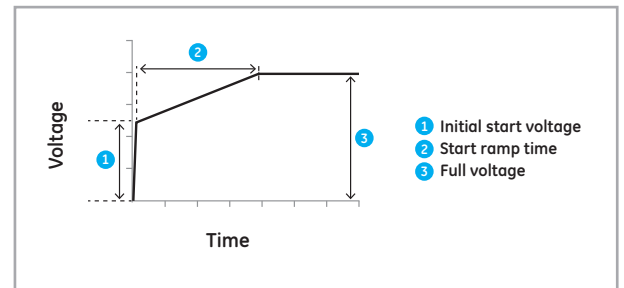

Constant Current (ASTAT XBm)

Constant current is the traditional form of soft starting, which raises the current from zero to a specified level and keeps the current stable at that level until the motor has accelerated.

Constant current starting is ideal for applications where the start current must be kept below a particular level.

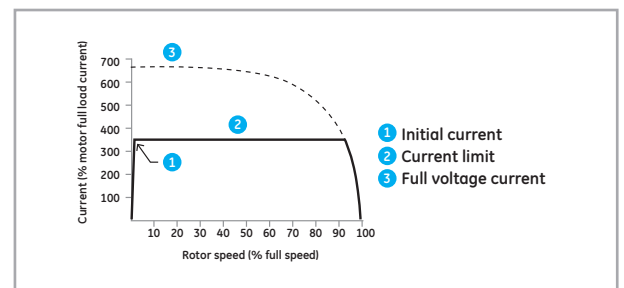

Current Ramp (ASTAT XBm)

Current ramp soft starting raises the current from a specified starting level (1) to a maximum limit (3), over an extended period of time (2).

Current ramp starting can be useful for applications where:

- the load can vary between starts
- the load breaks away easily, but starting time needs to be extended
- the electricity supply is limited

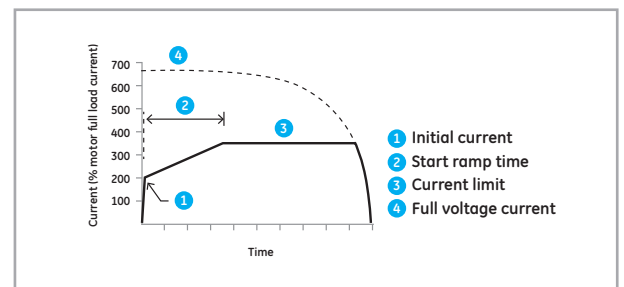

Easy configuration (ASTAT XB)

- 1 Select initial voltage (%) and start ramp time

Select stop ramp time (up to 20 seconds)

- 2 TVR stop adds inertia to the load and allows the motor to slow down gradually

For coast to stop, set Stop Ramp Time = No softstop



Easy configuration (ASTAT XBm)

- 1 Select current limit (% FLC)
Select initial current and start ramp time
Use current ramp for limited supplies (e.g. generator sets) and installations where the motor may start with varying loads

- 2 Motor FLC - Affects all protection and start settings.
Minimum FLC setting is 50% of the nameplate rating.

- 3 Soft stop - Select stop ramp time (up to 20 seconds)

Timed Voltage Ramp stop adds inertia to the load and allows the motor to slow down gradually

For coast to stop, set Stop Ramp Time = No soft stop

- 4 Protections - Motor Trip Class
Excess Start Time - selectable up to 20 seconds, plus built-in limit of 120 seconds ; Phase Sequence (combined with Aux Relay)



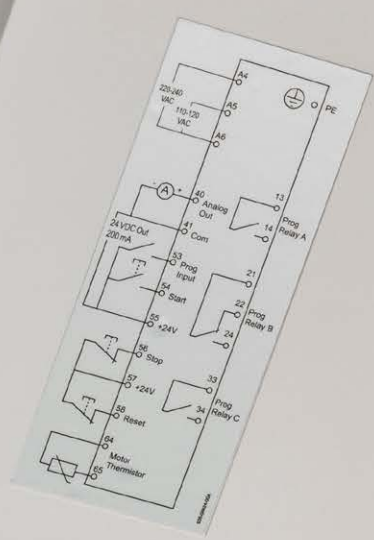

872296-QL21B580D
Part Desc: ASTAT XL 05000 VS C1
Rating: 3 Phase 200-520 VAC 50/60 Hz
980A AC 518-119 590 300W 4000hp 400VAC
S/N: 614208 424
Technical Support
www.ge.com/industry/solutions
For full technical details refer User Manual



Order codes

Output Power at		350%, 15 seconds		400%, 20 seconds		Mains voltage: 200 to 440V AC; Control voltage: 110 to 240V AC				Mains voltage: 200 to 575V AC; Control voltage: 110 to 240V AC			
400Vac (kW)	460Vac (HP)	NORMAL DUTY		HEAVY DUTY		ASTAT XB		ASTAT XBm		ASTAT XB		ASTAT XBm	
		AC53b 4-6:354		AC53b 4-20:340		Cat. No.	Ref. No.	Cat. No.	Ref. No.	Cat. No.	Ref. No.	Cat. No.	Ref. No.
		40°C	50°C	40°C	50°C								
7.5	10	18A	17A	17A	15A	QS11B018XA1	872411	QC11B018XA1	872869	QS31B018XA1	872078	QC31B018XA1	872153
15	20	34A	32A	30A	28A	QS11B034XA1	872858	QC11B034XA1	872870	QS31B034XA1	872080	QC31B034XA1	872154
18.5	25	42A	40A	36A	33A	QS11B042XA1	872859	QC11B042XA1	872871	QS31B042XA1	872085	QC31B042XA1	872155
22	30	48A	44A	40A	36A	QS11B048XA1	872861	QC11B048XA1	872872	QS31B048XA1	872090	QC31B048XA1	872159
30	40	60A	55A	49A	45A	QS11B060XA1	872862	QC11B060XA1	872873	QS31B060XA1	872099	QC31B060XA1	872173
		AC53b 4-6:594		AC53b 4-20:580									
		40°C	50°C	40°C	50°C								
37	50	75A	68A	65A	59A	QS11B075XA1	872863	QC11B075XA1	872874	QS31B075XA1	872118	QC31B075XA1	872175
45	60	85A	78A	73A	67A	QS11B085XA1	872864	QC11B085XA1	872875	QS31B085XA1	872123	QC31B085XA1	872183
55	75	100A	100A	96A	87A	QS11B100XA1	872865	QC11B100XA1	872876	QS31B100XA1	872124	QC31B100XA1	872184
75	100	140A	133A	120A	110A	QS11B140XA1	872866	QC11B140XA1	872877	QS31B140XA1	872125	QC31B140XA1	872185
90	125	170A	157A	142A	130A	QS11B170XA1	872867	QC11B170XA1	872878	QS31B170XA1	872135	QC31B170XA1	872186
110	150	200A	186A	165A	152A	QS11B200XA1	872868	QC11B200XA1	872879	QS31B200XA1	872146	QC31B200XA1	872187

Output Power at		350%, 15 seconds		400%, 20 seconds		Mains voltage: 200 to 440V AC; Control voltage: 24V AC/DC				Mains voltage: 200 to 575V AC; Control voltage: 24V AC/DC			
400Vac (kW)	460Vac (HP)	NORMAL DUTY		HEAVY DUTY		ASTAT XB		ASTAT XBm		ASTAT XB		ASTAT XBm	
		AC53b 4-6:354		AC53b 4-20:340		Cat. No.	Ref. No.	Cat. No.	Ref. No.	Cat. No.	Ref. No.	Cat. No.	Ref. No.
		40°C	50°C	40°C	50°C								
7.5	10	18A	17A	17A	15A	QS12B018XA1	873074	QC12B018XA1	873096	QS32B018XA1	873085	QC32B018XA1	873097
15	20	34A	32A	30A	28A	QS12B034XA1	873075	QC12B034XA1	873098	QS32B034XA1	873086	QC32B034XA1	873099
18.5	25	42A	40A	36A	33A	QS12B042XA1	873076	QC12B042XA1	873100	QS32B042XA1	873087	QC32B042XA1	873101
22	30	48A	44A	40A	36A	QS12B048XA1	873077	QC12B048XA1	873102	QS32B048XA1	873088	QC32B048XA1	873103
30	40	60A	55A	49A	45A	QS12B060XA1	873078	QC12B060XA1	873073	QS32B060XA1	873089	QC32B060XA1	873104
		AC53b 4-6:594		AC53b 4-20:580									
		40°C	50°C	40°C	50°C								
37	50	75A	68A	65A	59A	QS12B075XA1	873079	QC12B075XA1	873105	QS32B075XA1	873090	QC32B075XA1	873106
45	60	85A	78A	73A	67A	QS12B085XA1	873080	QC12B085XA1	873107	QS32B085XA1	873091	QC32B085XA1	873108
55	75	100A	100A	96A	87A	QS12B100XA1	873081	QC12B100XA1	873109	QS32B100XA1	873092	QC32B100XA1	873110
75	100	140A	133A	120A	110A	QS12B140XA1	873082	QC12B140XA1	873111	QS32B140XA1	873093	QC32B140XA1	873112
90	125	170A	157A	142A	130A	QS12B170XA1	873083	QC12B170XA1	873113	QS32B170XA1	873094	QC32B170XA1	873114
110	150	200A	186A	165A	152A	QS12B200XA1	873084	QC12B200XA1	873115	QS32B200XA1	873095	QC32B200XA1	873116

Above values are for altitude < 1000m/3300ft

AC53b Utilisation Code

80A : AC-53b 3.5 - 15 : 345

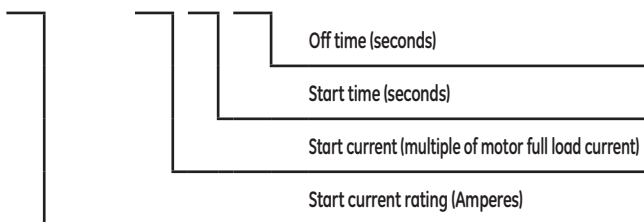

Starter Current Rating: The full load current rating of the soft starter given the parameters detailed in the remaining sections of the utilization code.

Start Current: The maximum available start current.

Start Time: The maximum allowable start time.

Off Time: The minimum allowable time between the end of one start and the beginning of the next start.

ASTAT XB and XBm Options

Description	Cat. No.	Ref. No.
Ethernet Communication module	QOEIP	872378
DeviceNet Communication module	QODEV	872379
Modbus RTU Communication module	QOMB	872383
Modbus TCP Communication module	QOMBTCP	872384
Profibus Communication module	QOPDP	872386
Profinet Communication module	QOPRT	872387
USB module	QOUSB	872388
Remote Control Panel	QORCPXB	872392
IP20 finger protection 140 to 200A	QOFPROTXB	872394



Order codes

Current ratings for bypass operation - In-line connection

		300%, 10 seconds	350%, 15 seconds	400%, 20 seconds	450%, 30 seconds	Mains voltage: 200 to 525V AC; Control voltage: 110 to 240V AC	Mains voltage: 380 to 690V AC; Control voltage: 110 to 240V AC
Output Power at		LIGHT DUTY	NORMAL DUTY	HEAVY DUTY	SEVERE DUTY	ASTAT XL	
400Vac (kW)	460Vac (HP)					Cat. No.	Ref. No.
		AC53b 3.0-10:350	AC53b 3.5-15:345	AC53b 4.0-20:340	AC53b 4.5-30:330		
40°C							
11	15	23 A	20 A	17 A	15 A	QL21B023DA1	872221
18,5	20	43 A	37 A	31 A	26 A	QL21B043DA1	872239
22	25	50 A	44 A	37 A	30 A	QL21B050DA1	872241
25	30	53 A	53 A	46 A	37 A	QL21B053DA1	872243
		AC53b 3.0-10:390	AC53b 3.5-15:385	AC53b 4.0-20:580	AC53b 4.5-30:570		
40°C							
30	40	76 A	64 A	55 A	47 A	QL21B076DA1	872245
37	50	97 A	82 A	69 A	58 A	QL21B097DA1	872246
45	60	100 A	88 A	74 A	61 A	QL21B100DA1	872247
55	75	105 A	105 A	95 A	78 A	QL21B105DA1	872248
55	75	145 A	123 A	106 A	90 A	QL21B145DA1	872249
75	100	170 A	145 A	121 A	97 A	QL21B170DA1	872256
90	125	200 A	189 A	160 A	134 A	QL21B200DA1	872258
110	150	220 A	210 A	178 A	148 A	QL21B220DA1	872274
132	200	255 A	231 A	201 A	176 A	QL21B255DA1	872276
160	250	255 A	231 A	201 A	176 A	QL21X255DA1	872312
200	300	350 A	329 A	284 A	244 A	QL21B350DA1	872284
250	350	360 A	360 A	310 A	263 A	QL21X360DA1	872318
315	450	380 A	380 A	359 A	299 A	QL21X380DA1	872320
400	550	425 A	411 A	355 A	305 A	QL21B425DA1	872292
450	600	430 A	430 A	368 A	309 A	QL21X430DA1	872322
500	650	500 A	445 A	383 A	326 A	QL21B500DA1	872294
560	750	580 A	492 A	425 A	364 A	QL21B580DA1	872296
132	200	620 A	620 A	540 A	434 A	QL21X620DA1	872324
160	250	650 A	650 A	561 A	455 A	QL21X650DA1	872328
160	250	700 A	592 A	512 A	438 A	QL21B700DA1	872302
200	300	790 A	790 A	714 A	579 A	QL21X790DA1	872330
315	450	820 A	705 A	606 A	516 A	QL21B820DA1	872303
355	500	920 A	804 A	684 A	571 A	QL21B920DA1	872304
450	600	930 A	930 A	829 A	661 A	QL21X930DA1	872332
500	650	1000 A	936 A	796 A	664 A	QL21B1K0DA1	872306
630	900	1200 A	1200 A	1200 A	1071 A	QL21X1K2DA1	872333
710	1000	1410 A	1410 A	1319 A	1114 A	QL21X1K4DA1	872334
800	1200	1600 A	1600 A	1600 A	1353 A	QL21X1K6DA1	872336
		AC53b 3.0-10:350	AC53b 3.5-15:345	AC53b 4.0-20:340	AC53b 4.5-30:330		
40°C							
11	15	23 A	20 A	17 A	15 A	QL22B023DA1	873119
18,5	20	43 A	37 A	31 A	26 A	QL22B043DA1	873120
22	25	50 A	44 A	37 A	30 A	QL22B050DA1	873121
25	30	53 A	53 A	46 A	37 A	QL22B053DA1	873122
		AC53b 3.0-10:390	AC53b 3.5-15:385	AC53b 4.0-20:580	AC53b 4.5-30:570		
40°C							
30	40	76 A	64 A	55 A	47 A	QL22B076DA1	873118
37	50	97 A	82 A	69 A	58 A	QL22B097DA1	873123
45	60	100 A	88 A	74 A	61 A	QL22B100DA1	873124
55	75	105 A	105 A	95 A	78 A	QL22B105DA1	873125
55	75	145 A	123 A	106 A	90 A	QL22B145DA1	873126
75	100	170 A	145 A	121 A	97 A	QL22B170DA1	873127
90	125	200 A	189 A	160 A	134 A	QL22B200DA1	873117
110	150	220 A	210 A	178 A	148 A	QL22B220DA1	873128
132	200	255 A	231 A	201 A	176 A	QL22B255DA1	873129
160	250	255 A	231 A	201 A	176 A	QL22X255DA1	873138
200	300	350 A	329 A	284 A	244 A	QL22B350DA1	873130
250	350	360 A	360 A	310 A	263 A	QL22X360DA1	873139
315	450	380 A	380 A	359 A	299 A	QL22X380DA1	873140
400	550	425 A	411 A	355 A	305 A	QL22B425DA1	873131
450	600	430 A	430 A	368 A	309 A	QL22X430DA1	873141
500	650	500 A	445 A	383 A	326 A	QL22B500DA1	873132
560	750	580 A	492 A	425 A	364 A	QL22B580DA1	873133
132	200	620 A	620 A	540 A	434 A	QL22X620DA1	873142
160	250	650 A	650 A	561 A	455 A	QL22X650DA1	873143
160	250	700 A	592 A	512 A	438 A	QL22B700DA1	873134
200	300	790 A	790 A	714 A	579 A	QL22X790DA1	873144
315	450	820 A	705 A	606 A	516 A	QL22B820DA1	873135
355	500	920 A	804 A	684 A	571 A	QL22B920DA1	873136
450	600	930 A	930 A	829 A	661 A	QL22X930DA1	873145
500	650	1000 A	936 A	796 A	664 A	QL22B1K0DA1	873137
630	900	1200 A	1200 A	1200 A	1071 A	QL22X1K2DA1	873146
710	1000	1410 A	1410 A	1319 A	1114 A	QL22X1K4DA1	873147
800	1200	1600 A	1600 A	1600 A	1353 A	QL22X1K6DA1	873148

Above values are for altitude < 1000m/3300ft



Order codes

Current ratings for bypass operation - Inside delta connection

Output Power at		300%, 10 seconds	350%, 15 seconds	400%, 20 seconds	450%, 30 seconds	Mains voltage: 200 to 525V AC; Control voltage: 110 to 240V AC		Mains voltage: 380 to 690V AC; Control voltage: 110 to 240V AC	
400Vac (kW)	460Vac (HP)	LIGHT DUTY	NORMAL DUTY	HEAVY DUTY	SEVERE DUTY	ASTAT XL		ASTAT XL	
						Cat. No.	Ref. No.	Cat. No.	Ref. No.
		AC53b 3.0-10:350	AC53b 3.5-15:345	AC53b 4.0-20:340	AC53b 4.5-30:330				
40°C									
11	15	34 A	30 A	26 A	22 A	QL21B023DA1	872221	QL41B023DA1	872337
18.5	20	64 A	59 A	51 A	44 A	QL21B043DA1	872239	QL41B043DA1	872338
22	25	75 A	66 A	55 A	45 A	QL21B050DA1	872241	QL41B050DA1	872339
25	30	79 A	79 A	69 A	55 A	QL21B053DA1	872243	QL41B053DA1	872340
		AC53b 3.0-10:390	AC53b 3.5-15:385	AC53b 4.0-20:580	AC53b 4.5-30:570				
40°C									
30	40	114 A	96 A	83 A	70 A	QL21B076DA1	872245	QL41B076DA1	872342
37	50	145 A	123 A	104 A	87 A	QL21B097DA1	872246	QL41B097DA1	872343
45	60	150 A	132 A	112 A	92 A	QL21B100DA1	872247	QL41B100DA1	872344
55	75	157 A	157 A	143 A	117 A	QL21B105DA1	872248	QL41B105DA1	872346
55	75	218 A	184 A	159 A	136 A	QL21B145DA1	872249	QL41B145DA1	872347
75	100	255 A	217 A	181 A	146 A	QL21B170DA1	872256	QL41B170DA1	872351
90	125	300 A	283 A	241 A	200 A	QL21B200DA1	872258	QL41B200DA1	872352
110	150	330 A	315 A	268 A	223 A	QL21B220DA1	872274	QL41B220DA1	872353
132	200	382 A	346 A	302 A	264 A	QL21B255DA1	872276	QL41B255DA1	872354
160	250	382 A	346 A	302 A	264 A	QL21X255DA1	872312	QL41X255DA1	872364
200	300	525 A	494 A	427 A	366 A	QL21B350DA1	872284	QL41B350DA1	872356
250	350	540 A	540 A	465 A	395 A	QL21X360DA1	872318	QL41X360DA1	872365
315	450	570 A	570 A	539 A	449 A	QL21X380DA1	872320	QL41X380DA1	872366
400	550	638 A	617 A	533 A	458 A	QL21B425DA1	872292	QL41B425DA1	872357
450	600	645 A	645 A	552 A	464 A	QL21X430DA1	872322	QL41X430DA1	872368
500	650	750 A	668 A	575 A	490 A	QL21B500DA1	872294	QL41B500DA1	872358
560	750	870 A	738 A	637 A	546 A	QL21B580DA1	872296	QL41B580DA1	872359
132	200	930 A	930 A	810 A	651 A	QL21X620DA1	872324	QL41X620DA1	872369
160	250	975 A	975 A	842 A	683 A	QL21X650DA1	872328	QL41X650DA1	872370
160	250	1050 A	889 A	768 A	658 A	QL21B700DA1	872302	QL41B700DA1	872360
200	300	1185 A	1185 A	1071 A	868 A	QL21X790DA1	872330	QL41X790DA1	872371
315	450	1230 A	1058 A	910 A	774 A	QL21B820DA1	872303	QL41B820DA1	872361
355	500	1380 A	1206 A	1026 A	857 A	QL21B920DA1	872304	QL41B920DA1	872362
450	600	1395 A	1395 A	1244 A	992 A	QL21X930DA1	872332	QL41X930DA1	872372
500	650	1500 A	1404 A	1194 A	997 A	QL21B1K0DA1	872306	QL41B1K0DA1	872363
630	900	1800 A	1800 A	1800 A	1606 A	QL21X1K2DA1	872333	QL41X1K2DA1	872373
710	1000	2115 A	2115 A	1979 A	1671 A	QL21X1K4DA1	872334	QL41X1K4DA1	872374
800	1200	2400 A	2400 A	2400 A	2030 A	QL21X1K6DA1	872336	QL41X1K6DA1	872376
		300%, 10 seconds	350%, 15 seconds	400%, 20 seconds	450%, 30 seconds	Mains voltage: 200 to 525V AC; Control voltage: 24V AC/DC		Mains voltage: 380 to 690V AC; Control voltage: 24V AC/DC	
400Vac (kW)	460Vac (HP)	LIGHT DUTY	NORMAL DUTY	HEAVY DUTY	SEVERE DUTY	ASTAT XL		ASTAT XL	
						Cat. No.	Ref. No.	Cat. No.	Ref. No.
		AC53b 3.0-10:350	AC53b 3.5-15:345	AC53b 4.0-20:340	AC53b 4.5-30:330				
40°C									
11	15	34 A	30 A	26 A	22 A	QL22B023DA1	873119	QL42B023DA1	873149
18.5	20	64 A	59 A	51 A	44 A	QL22B043DA1	873120	QL42B043DA1	873150
22	25	75 A	66 A	55 A	45 A	QL22B050DA1	873121	QL42B050DA1	873151
25	30	79 A	79 A	69 A	55 A	QL22B053DA1	873122	QL42B053DA1	873152
		AC53b 3.0-10:390	AC53b 3.5-15:385	AC53b 4.0-20:580	AC53b 4.5-30:570				
40°C									
30	40	114 A	96 A	83 A	70 A	QL22B076DA1	873118	QL42B076DA1	873153
37	50	145 A	123 A	104 A	87 A	QL22B097DA1	873123	QL42B097DA1	873154
45	60	150 A	132 A	112 A	92 A	QL22B100DA1	873124	QL42B100DA1	873155
55	75	157 A	157 A	143 A	117 A	QL22B105DA1	873125	QL42B105DA1	873156
55	75	218 A	184 A	159 A	136 A	QL22B145DA1	873126	QL42B145DA1	873157
75	100	255 A	217 A	181 A	146 A	QL22B170DA1	873127	QL42B170DA1	873158
90	125	300 A	283 A	241 A	200 A	QL22B200DA1	873117	QL42B200DA1	873159
110	150	330 A	315 A	268 A	223 A	QL22B220DA1	873128	QL42B220DA1	873160
132	200	382 A	346 A	302 A	264 A	QL22B255DA1	873129	QL42B255DA1	873161
160	250	382 A	346 A	302 A	264 A	QL22X255DA1	873138	QL42X255DA1	873170
200	300	525 A	494 A	427 A	366 A	QL22B350DA1	873130	QL42B350DA1	873162
250	350	540 A	540 A	465 A	395 A	QL22X360DA1	873139	QL42X360DA1	873171
315	450	570 A	570 A	539 A	449 A	QL22X380DA1	873140	QL42X380DA1	873172
400	550	638 A	617 A	533 A	458 A	QL22B425DA1	873131	QL42B425DA1	873163
450	600	645 A	645 A	552 A	464 A	QL22X430DA1	873141	QL42X430DA1	873173
500	650	750 A	668 A	575 A	490 A	QL22B500DA1	873132	QL42B500DA1	873164
560	750	870 A	738 A	637 A	546 A	QL22B580DA1	873133	QL42B580DA1	873165
132	200	930 A	930 A	810 A	651 A	QL22X620DA1	873142	QL42X620DA1	873174
160	250	975 A	975 A	842 A	683 A	QL22X650DA1	873143	QL42X650DA1	873175
160	250	1050 A	889 A	768 A	658 A	QL22B700DA1	873134	QL42B700DA1	873166
200	300	1185 A	1185 A	1071 A	868 A	QL22X790DA1	873144	QL42X790DA1	873176
315	450	1230 A	1058 A	910 A	774 A	QL22B820DA1	873135	QL42B820DA1	873167
355	500	1380 A	1206 A	1026 A	857 A	QL22B920DA1	873136	QL42B920DA1	873168
450	600	1395 A	1395 A	1244 A	992 A	QL22X930DA1	873145	QL42X930DA1	873177
500	650	1500 A	1404 A	1194 A	997 A	QL22B1K0DA1	873137	QL42B1K0DA1	873169
630	900	1800 A	1800 A	1800 A	1606 A	QL22X1K2DA1	873146	QL42X1K2DA1	873178
710	1000	2115 A	2115 A	1979 A	1671 A	QL22X1K4DA1	873147	QL42X1K4DA1	873179
800	1200	2400 A	2400 A	2400 A	2030 A	QL22X1K6DA1	873148	QL42X1K6DA1	873180

Note: Models QLxxX__DA1 must be externally bypassed
Above values are for altitude < 1000m/3300ft



Order codes

Current ratings for continuous operation (not bypassed) - In-line connection

Output Power at		300%, 10 seconds	350%, 15 seconds	400%, 20 seconds	450%, 30 seconds	Mains voltage: 200 to 525V AC; Control voltage: 110 to 240V AC		Mains voltage: 380 to 690V AC; Control voltage: 110 to 240V AC	
400Vac (kW)	460Vac (HP)	LIGHT DUTY	NORMAL DUTY	HEAVY DUTY	SEVERE DUTY	ASTAT XL		ASTAT XL	
		AC53b 3-10:50-6	AC53b 3.5-15:50-6	AC53b 4-20:50-6	AC53b 4.5-30:50-6	Cat. No.	Ref. No.	Cat. No.	Ref. No.
40°C									
132	200	255 A	222 A	195 A	171 A	QL21X255DA1	872312	QL41X255DA1	872364
160	250	360 A	351 A	303 A	259 A	QL21X360DA1	872318	QL41X360DA1	872365
160	250	380 A	380 A	348 A	292 A	QL21X380DA1	872320	QL41X380DA1	872366
200	300	430 A	413 A	355 A	301 A	QL21X430DA1	872322	QL41X430DA1	872368
315	450	620 A	614 A	515 A	419 A	QL21X620DA1	872324	QL41X620DA1	872369
355	500	650 A	629 A	532 A	437 A	QL21X650DA1	872328	QL41X650DA1	872370
450	600	790 A	790 A	694 A	567 A	QL21X790DA1	872330	QL41X790DA1	872371
500	650	930 A	930 A	800 A	644 A	QL21X930DA1	872332	QL41X930DA1	872372
630	900	1200 A	1200 A	1135 A	983 A	QL21X1K2DA1	872333	QL41X1K2DA1	872373
710	1000	1410 A	1355 A	1187 A	1023 A	QL21X1K4DA1	872334	QL41X1K4DA1	872374
800	1200	1600 A	1600 A	1433 A	1227 A	QL21X1K6DA1	872336	QL41X1K6DA1	872376

Output Power at		300%, 10 seconds	350%, 15 seconds	400%, 20 seconds	450%, 30 seconds	Mains voltage: 200 to 525V AC; Control voltage: 24V AC/DC		Mains voltage: 380 to 690V AC; Control voltage: 24V AC/DC	
400Vac (kW)	460Vac (HP)	LIGHT DUTY	NORMAL DUTY	HEAVY DUTY	SEVERE DUTY	ASTAT XL		ASTAT XL	
		AC53b 3-10:50-6	AC53b 3.5-15:50-6	AC53b 4-20:50-6	AC53b 4.5-30:50-6	Cat. No.	Ref. No.	Cat. No.	Ref. No.
40°C									
132	200	255 A	222 A	195 A	171 A	QL21X255DA1	872312	QL41X255DA1	872364
160	250	360 A	351 A	303 A	259 A	QL21X360DA1	872318	QL41X360DA1	872365
160	250	380 A	380 A	348 A	292 A	QL21X380DA1	872320	QL41X380DA1	872366
200	300	430 A	413 A	355 A	301 A	QL21X430DA1	872322	QL41X430DA1	872368
315	450	620 A	614 A	515 A	419 A	QL21X620DA1	872324	QL41X620DA1	872369
355	500	650 A	629 A	532 A	437 A	QL21X650DA1	872328	QL41X650DA1	872370
450	600	790 A	790 A	694 A	567 A	QL21X790DA1	872330	QL41X790DA1	872371
500	650	930 A	930 A	800 A	644 A	QL21X930DA1	872332	QL41X930DA1	872372
630	900	1200 A	1200 A	1135 A	983 A	QL21X1K2DA1	872333	QL41X1K2DA1	872373
710	1000	1410 A	1355 A	1187 A	1023 A	QL21X1K4DA1	872334	QL41X1K4DA1	872374
800	1200	1600 A	1600 A	1433 A	1227 A	QL21X1K6DA1	872336	QL41X1K6DA1	872376

Above values are for altitude < 1000m/3300ft

Current ratings for continuous operation (not bypassed) - Inside delta connection

Output Power at		300%, 10 seconds	350%, 15 seconds	400%, 20 seconds	450%, 30 seconds	Mains voltage: 200 to 525V AC; Control voltage: 110 to 240V AC		Mains voltage: 380 to 690V AC; Control voltage: 110 to 240V AC	
400Vac (kW)	460Vac (HP)	LIGHT DUTY	NORMAL DUTY	HEAVY DUTY	SEVERE DUTY	ASTAT XL		ASTAT XL	
		AC53b 3-10:50-6	AC53b 3.5-15:50-6	AC53b 4-20:50-6	AC53b 4.5-30:50-6	Cat. No.	Ref. No.	Cat. No.	Ref. No.
40°C									
132	200	382 A	334 A	293 A	257 A	QL21X255DA1	872312	QL41X255DA1	872364
160	250	540 A	527 A	455 A	388 A	QL21X360DA1	872318	QL41X360DA1	872365
160	250	570 A	570 A	522 A	437 A	QL21X380DA1	872320	QL41X380DA1	872366
200	300	645 A	620 A	533 A	451 A	QL21X430DA1	872322	QL41X430DA1	872368
315	450	930 A	920 A	773 A	628 A	QL21X620DA1	872324	QL41X620DA1	872369
355	500	975 A	943 A	798 A	656 A	QL21X650DA1	872328	QL41X650DA1	872370
450	600	1185 A	1185 A	1041 A	850 A	QL21X790DA1	872330	QL41X790DA1	872371
500	650	1395 A	1395 A	1200 A	966 A	QL21X930DA1	872332	QL41X930DA1	872372
630	900	1800 A	1800 A	1702 A	1474 A	QL21X1K2DA1	872333	QL41X1K2DA1	872373
710	1000	2115 A	2033 A	1780 A	1535 A	QL21X1K4DA1	872334	QL41X1K4DA1	872374
800	1200	2400 A	2400 A	2149 A	1840 A	QL21X1K6DA1	872336	QL41X1K6DA1	872376

Output Power at		300%, 10 seconds	350%, 15 seconds	400%, 20 seconds	450%, 30 seconds	Mains voltage: 200 to 525V AC; Control voltage: 24V AC/DC		Mains voltage: 380 to 690V AC; Control voltage: 24V AC/DC	
400Vac (kW)	460Vac (HP)	LIGHT DUTY	NORMAL DUTY	HEAVY DUTY	SEVERE DUTY	ASTAT XL		ASTAT XL	
		AC53b 3-10:50-6	AC53b 3.5-15:50-6	AC53b 4-20:50-6	AC53b 4.5-30:50-6	Cat. No.	Ref. No.	Cat. No.	Ref. No.
40°C									
132	200	382 A	334 A	293 A	257 A	QL21X255DA1	872312	QL41X255DA1	872364
160	250	540 A	527 A	455 A	388 A	QL21X360DA1	872318	QL41X360DA1	872365
160	250	570 A	570 A	522 A	437 A	QL21X380DA1	872320	QL41X380DA1	872366
200	300	645 A	620 A	533 A	451 A	QL21X430DA1	872322	QL41X430DA1	872368
315	450	930 A	920 A	773 A	628 A	QL21X620DA1	872324	QL41X620DA1	872369
355	500	975 A	943 A	798 A	656 A	QL21X650DA1	872328	QL41X650DA1	872370
450	600	1185 A	1185 A	1041 A	850 A	QL21X790DA1	872330	QL41X790DA1	872371
500	650	1395 A	1395 A	1200 A	966 A	QL21X930DA1	872332	QL41X930DA1	872372
630	900	1800 A	1800 A	1702 A	1474 A	QL21X1K2DA1	872333	QL41X1K2DA1	872373
710	1000	2115 A	2033 A	1780 A	1535 A	QL21X1K4DA1	872334	QL41X1K4DA1	872374
800	1200	2400 A	2400 A	2149 A	1840 A	QL21X1K6DA1	872336	QL41X1K6DA1	872376

Above values are for altitude < 1000m/3300ft



Minimum and Maximum Current settings

Model	In-line connection		Inside delta connection	
	Minimum	Maximum	Minimum	Maximum
QLxxB023D	5A	23A	5A	34A
QLxxB043D	9A	43A	9A	64A
QLxxB050D	10A	50A	10A	75A
QLxxB053D	11A	53A	11A	79A
QLxxB076D	15A	76A	15A	114A
QLxxB097D	19A	97A	19A	145A
QLxxB100D	20A	100A	20A	150A
QLxxB105D	21A	105A	21A	157A
QLxxB145D	29A	145A	29A	217A
QLxxB170D	34A	170A	34A	255A
QLxxB200D	40A	200A	40A	300A
QLxxB220D	44A	220A	44A	330A
QLxxB255D	51A	255A	51A	382A
QLxxX255D	51A	255A	51A	382A
QLxxB350D	70A	350A	70A	525A
QLxxX360D	72A	360A	72A	540A
QLxxX380D	76A	380A	76A	570A
QLxxB425D	85A	425A	85A	638A
QLxxX430D	86A	430A	86A	645A
QLxxB500D	100A	500A	100A	750A
QLxxB580D	116A	580A	116A	870A
QLxxX620D	124A	620A	124A	930A
QLxxX650D	130A	650A	130A	975A
QLxxB700D	140A	700A	140A	1050A
QLxxX790D	158A	790A	158A	1185A
QLxxB820D	164A	820A	164A	1230A
QLxxB920D	184A	920A	184A	1380A
QLxxX930D	186A	930A	186A	1395A
QLxxB1K0D	200A	1000A	200A	1500A
QLxxX1K2D	240A	1200A	240A	1800A
QLxxX1K4D	282A	1410A	282A	2115A
QLxxX1K6D	320A	1600A	320A	2400A

ASTAT XL Options

Description	Cat. No.	Ref. No.
Ethernet Communication module	QOEIP	872378
DeviceNet Communication module	QODEV	872379
Modbus RTU Communication module	QOMB	872383
Modbus TCP Communication module	QOMBTCP	872384
Profibus Communication module	QOPDP	872386
Profinet Communication module	QOPRT	872387
USB module	QOUSB	872388
Remote Control Panel	QORCPXL	872391
IP20 finger protection 145 to 220A	QOFPROTXL2	872395
IP20 finger protection 255 to 425A	QOFPROTXL3	872396
IP20 finger protection 500 to 1000A	QOFPROTXL4	872399



ASTAT XB - XBm - XL

Dimensions

ASTAT XB and XBm

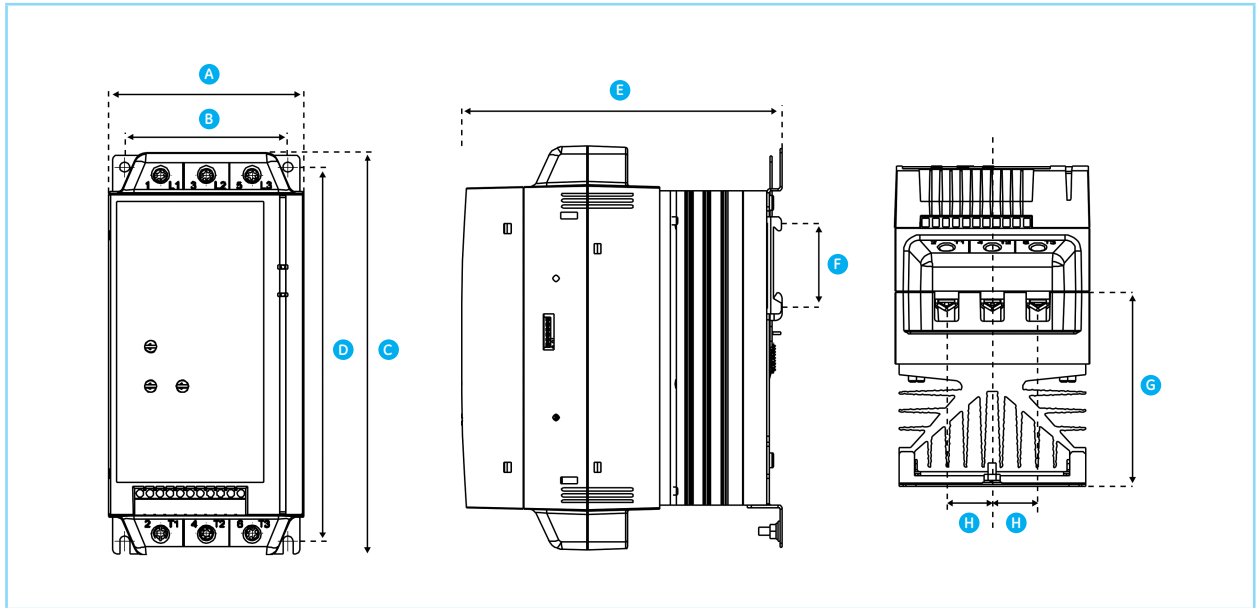

Dimensions in mm (inch)

Model	A Width	B Width	C Height	D Height	E Depth	F	G	H	Weight kg (lb)
QS/QCxxB018X	98 (3.85)	82 (3.22)	201 (7.91)	188 (7.40)	165 (6.49)	55 (2.16)	90,5 (3.6)	23 (0.9)	2.1 (4.6)
QS/QCxxB034X									
QS/QCxxB042X									
QS/QCxxB048X									
QS/QCxxB060X	145 (5.70)	124 (4.88)	215 (8.46)	196 (7.71)	193 (7.59)		110,5 (4.4)	37 (1.5)	3.8 (8.4)
QS/QCxxB075X									
QS/QCxxB085X									
QS/QCxxB100X	200 (7.87)	160 (6.29)	240 (9.44)	216 (8.50)	214 (8.42)		114,5 (4.5)	51 (2.0)	6.1 (13.5)
QS/QCxxB140X									
QS/QCxxB170X									
QS/QCxxB200X									

Remote operator of ASTAT XB and XBm

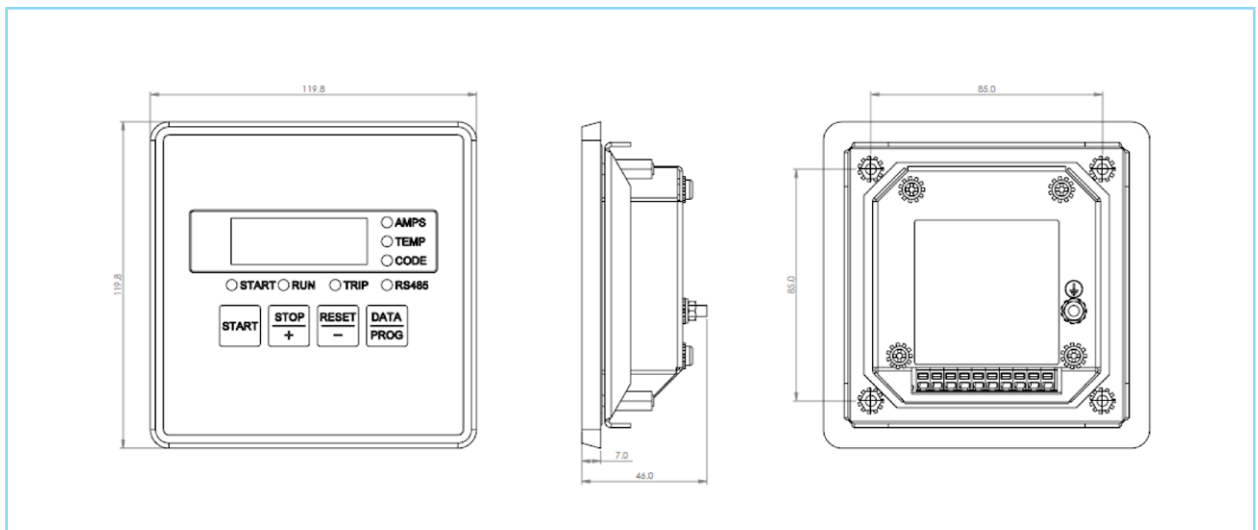

Dimensions in mm (inch = mm x 0.03937) - Weight in kg (lb = kg x 2.2046)



Dimensions ASTAT XL

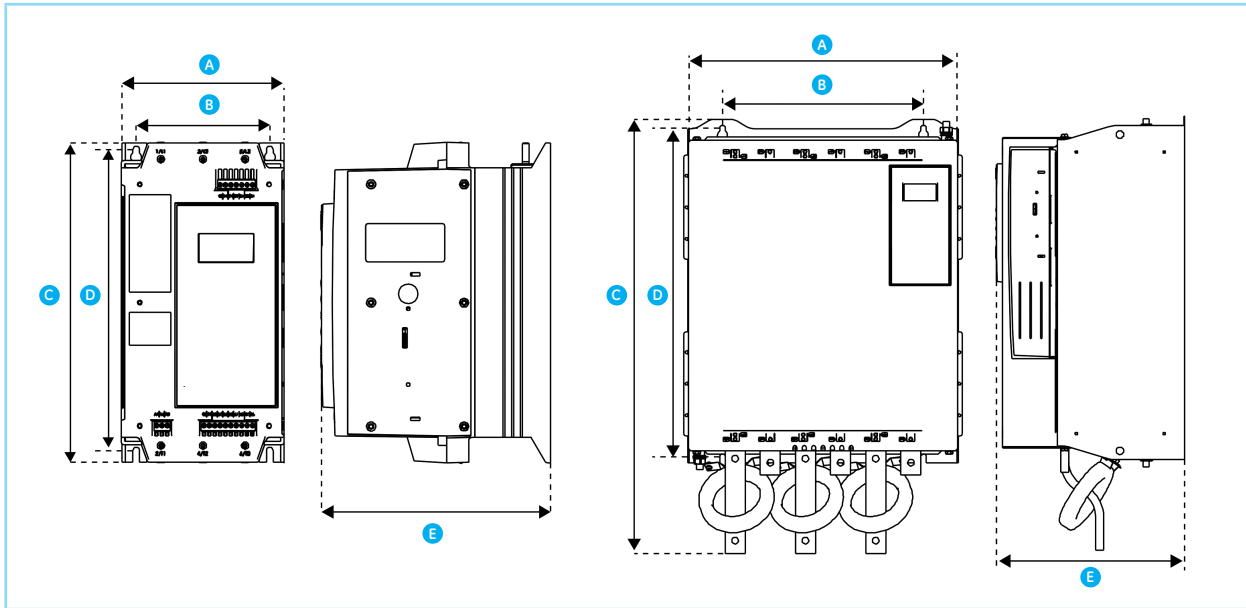

Dimensions in mm (inch)

Model	A Width	B Width	C Height	D Height	E Depth	Weight kg (lb)
QLxxB0023D						
QLxxB0043D					183 (7.2)	4.1 (9.0)
QLxxB0050D						
QLxxB0053D	150 (5.9)	124 (4.9)	295 (11.6)	278 (10.9)		4.4 (9.7)
QLxxB0076D						
QLxxB0097D					213 (8.4)	4.9 (10.8)
QLxxB0100D						
QLxxB0105D						13.6 (30.0)
QLxxB0145D						13.8 (30.4)
QLxxB0170D	275 (10.8)	250 (9.8)	438 (17.2)	380 (15.0)	248 (9.8)	
QLxxB0200D						14.6 (32.2)
QLxxB0220D						26 (57.3)
QLxxB0255D						
QLxxB0350D	424 (16.7)	376 (14.8)	440 (17.3)	392 (15.4)	296 (11.7)	29.4 (64.8)
QLxxB0425D						49 (108.0)
QLxxB0500D						
QLxxB0580D						
QLxxB0700D	433 (17.0)	320 (12.6)	640 (25.2)	600 (23.6)	293 (11.5)	62.5 (137.8)
QLxxB0820D						
QLxxB0920D						63 (138.9)
QLxxB1000D						
QLxxX0255D	390 (15.4)	320 (12.6)	460 (18.1)	400 (15.7)	278 (10.9)	23 (50.7)
QLxxX0360D						
QLxxX0380D						36 (79.4)
QLxxX0430D						
QLxxX0620D	430 (16.9)	320 (12.6)	689 (27.1)	522 (20.6)	301 (11.9)	
QLxxX0650D						39.5 (87.1)
QLxxX0790D						
QLxxX0930D						51.5 (113.5)
QLxxX1200D						128.5 (283.3)
QLxxX1410D	574 (22.6)	500 (19.7)	860 (33.9)	727 (28.6)	362 (14.3)	130 (286.6)
QLxxX1600D						140 (308.6)

Dimensions in mm (inch = mm x 0.03937) - Weight in kg (lb = kg x 2.2046)



ASTAT XB - XBm - XL

Dimensions

ASTAT XL remote control panel

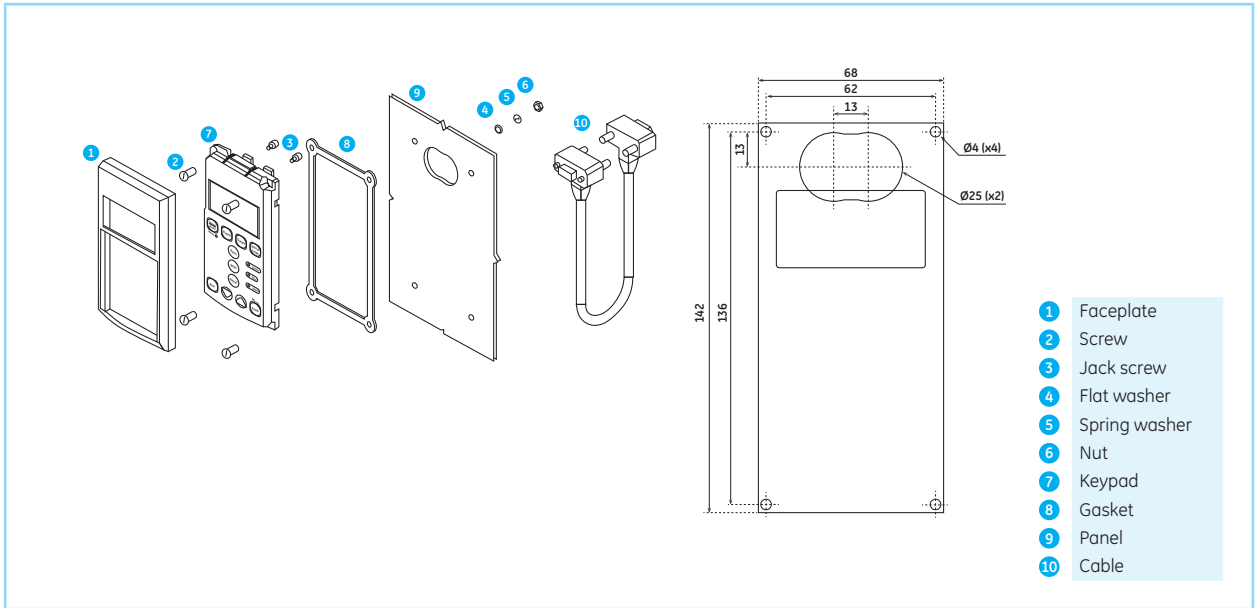

Soft starters

Communication modules

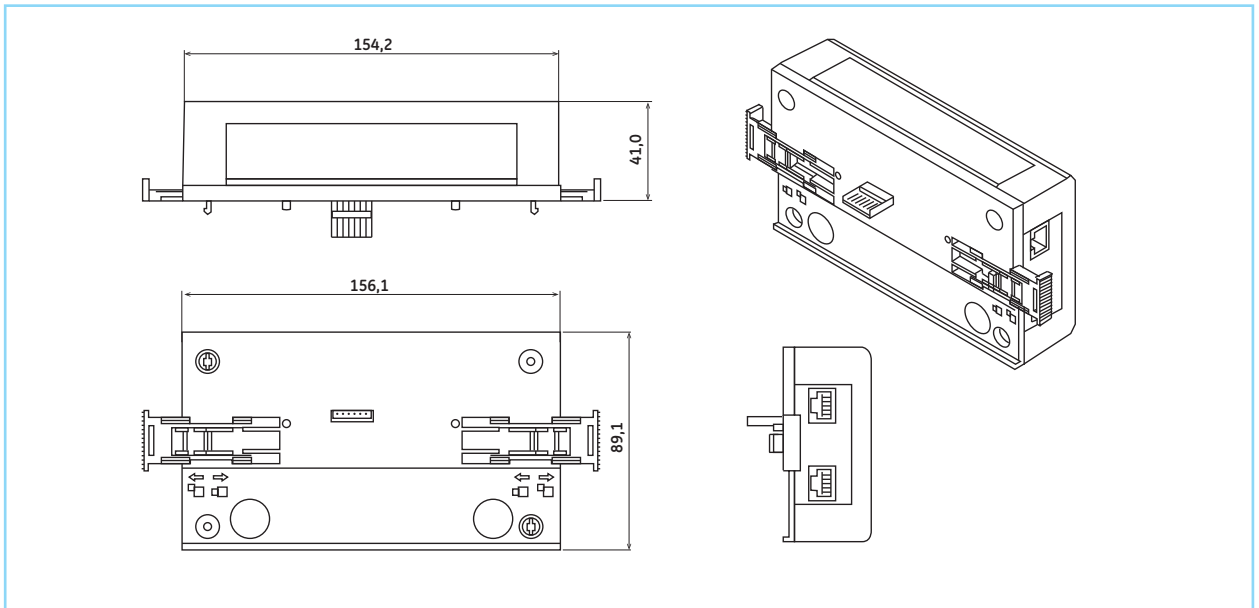

Dimensions in mm (inch = mm x 0.03937) - Weight in kg (lb = kg x 2.2046)



Basic wiring diagrams ASTAT XB

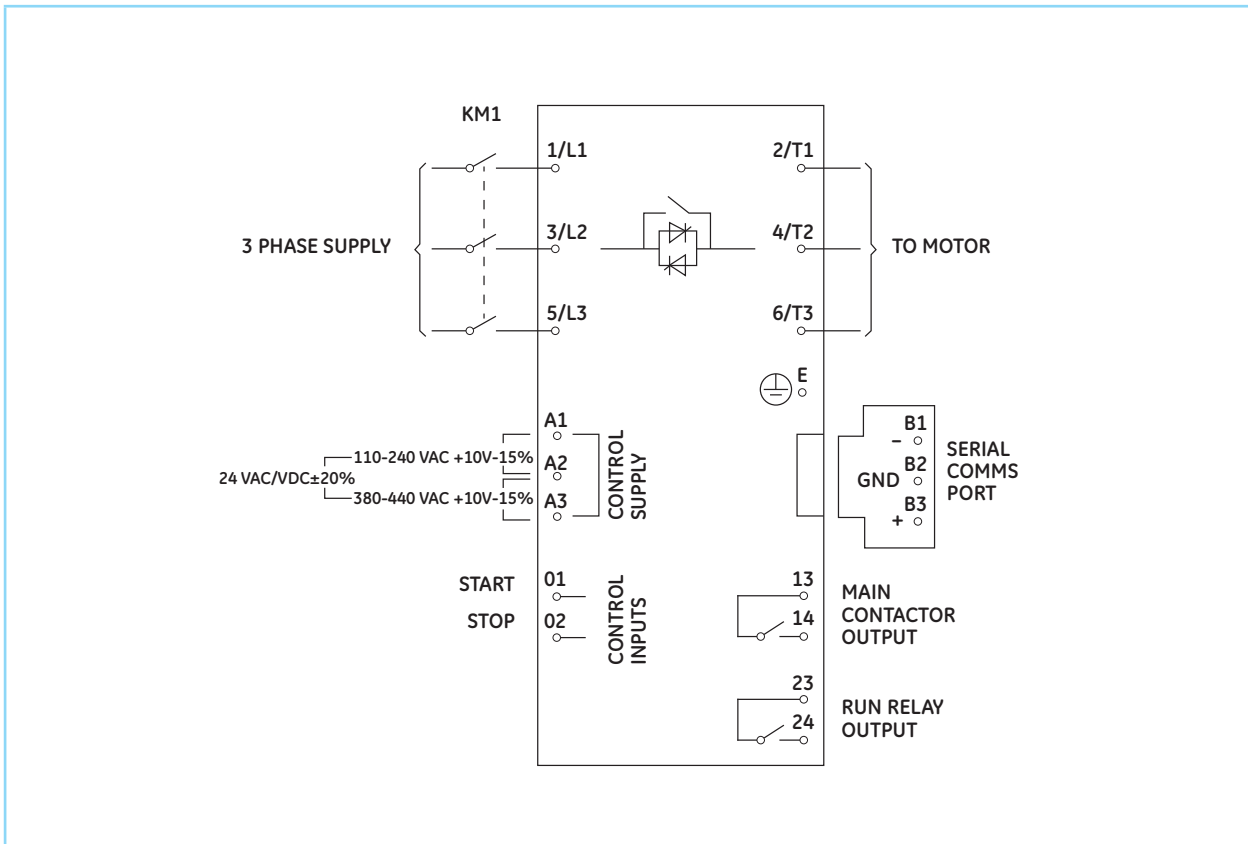

ASTAT XBm

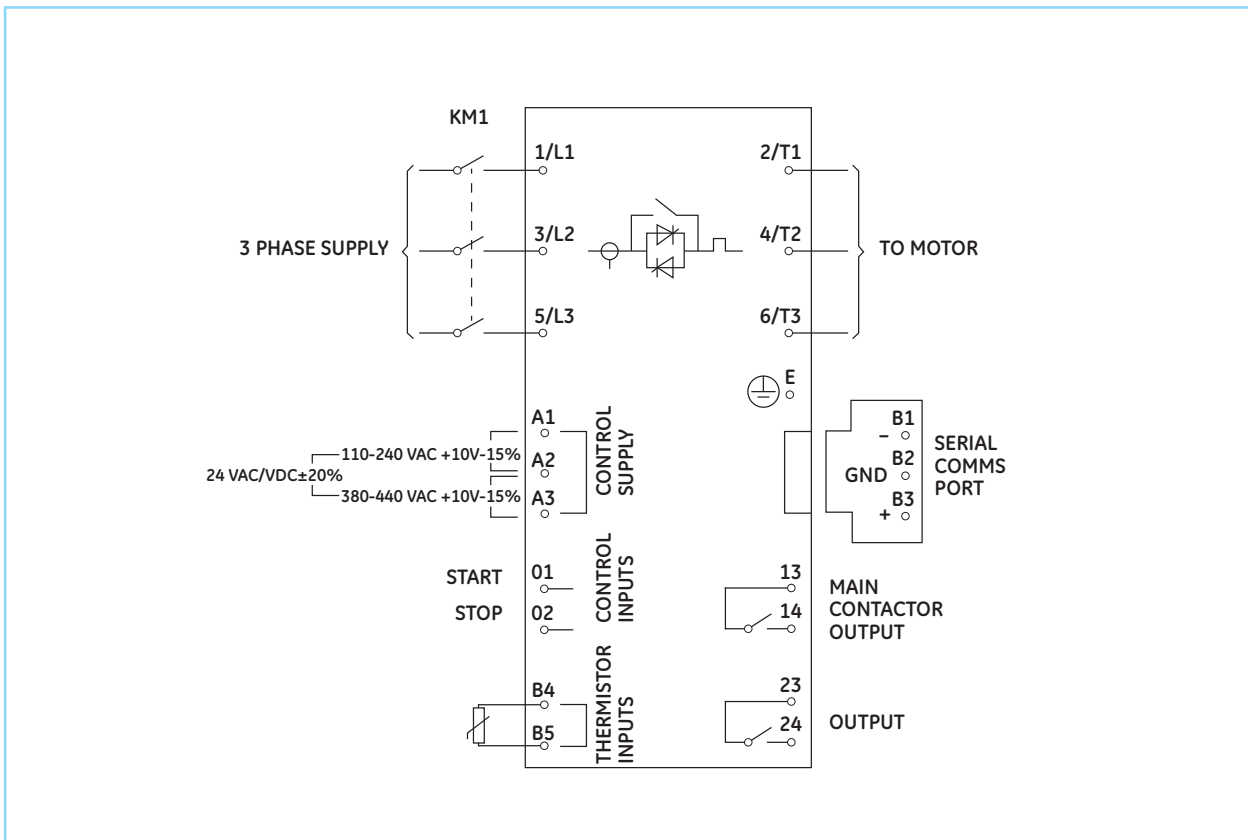

Semiconductor Fuses

Semiconductor fuses can be used with ASTAT XB and XBm soft starters to reduce the potential for damage to SCRs from transient overload currents and for Type 2 coordination. ASTAT XB and XBm soft starters have been tested to achieve Type 2 coordination with semiconductor fuses. Suitable Bussmann and Ferraz/Mersen semiconductor fuses are detailed below:

Model	SCR I ² t (A ² s)	Ferraz/Mersen Fuse European/IEC style (North American style)	Bussmann Fuse Square body	Bussmann Fuse British style (BS88)
QS/QCxx018	1150	6.6URD30xxxA0063 (A070URD30xxx0063)	170M-1314	63 FE
QS/QCxx034	8000	6.6URD30xxxA0125 (A070URD30xxx0125)	170M-1317	160 FEE
QS/QCxx042	10500	6.6URD30xxxA0160 (A070URD30xxx0160)	170M-1318	160 FEE
QS/QCxx048	15000	6.6URD30xxxA0160 (A070URD30xxx0160)	170M-1318	180 FM
QS/QCxx060	18000	6.6URD30xxxA0160 (A070URD30xxx0160)	170M-1319	180 FM
QS/QCxx075	51200	6.6URD30xxxA0250 (A070URD30xxx0250)	170M-1321	250 FM
QS/QCxx085	80000	6.6URD30xxxA0315 (A070URD30xxx0315)	170M-1321	250 FM
QS/QCxx100	97000	6.6URD30xxxA0315 (A070URD30xxx0315)	170M-1321	250 FM
QS/QCxx140	168000	6.6URD31xxxA0450 (A070URD31xxx0450)	170M-1322	500 FMM
QS/QCxx170	245000	6.6URD31xxxA0450 (A070URD31xxx0450)	170M-3022	500 FMM
QS/QCxx200	320000	6.6URD31xxxA0450 (A070URD31xxx0450)	170M-3022	500 FMM

ASTAT XL: see pages 69 to 75 from User Manual of ASTAT XL.



ASTAT XL - Adaptive Control

New soft start control type that allows the selection of different acceleration and deceleration profiles according to application needs.

Gradual and shock free acceleration can benefit all motor applications, but many situations need more precise control over acceleration and/or deceleration. Ideal for pump stopping: Match the deceleration profile to the unique hydraulic characteristics of the individual system.

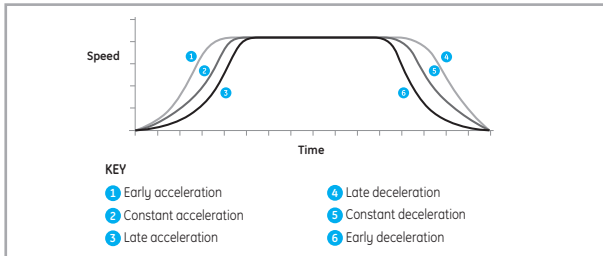

Two algorithms

Adaptive control is based on two algorithms, one for measuring (learning) the motor characteristics and one for controlling the motor

Starting and stopping profiles

The control algorithm defines starting and stopping profiles which relate motor speed to elapsed time.

Comparison

During each start and stop, adaptive control compares the motor's estimated speed with the selected profile.

Refining the model

The algorithm refines its model with data from every subsequent start and stop.

First soft start

During the first soft start the measuring algorithm measures the motor's characteristics at zero speed and at maximum efficiency

Up to six profiles

ASTAT XL allows for control with three acceleration and three deceleration profiles.

Adjustment

The soft starter then adjusts the power to the motor to achieve the selected profile (more power if the estimated speed is too low, less power if the speed is too high).

Fine tuning

The user can fine tune the adaptive control gain for smoother performance.

Kickstart (ASTAT XL)

Provides a short boost of extra torque at the beginning of a start, and can be used in conjunction with current ramp or constant current starting.

Kickstart can be useful to help start loads that require high breakaway torque but then accelerate easily (for example: flywheel loads such as presses).

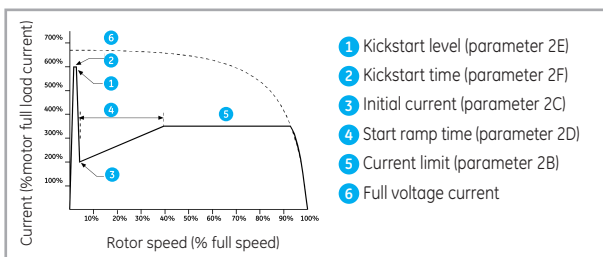

Other features

Emergency Run Mode (Fire mode)

In some cases, the equipment must run at all costs (eg ventilation fans in high rise buildings must run in case of fire, regardless of the risk to the

starter). It initiates a start and deactivates all protections, allowing the motor to run as long as possible.

Dual Parameter Set

Supports two sets of motor data and start/stop profile:

- duty-standby pumps
- different start performance for varying load conditions
- soft braking

PowerThrough

The starter can operate in two-phase control if one SCR is damaged. This allows continued operation while arranging repairs.

Auto-Reset

Auto-reset selected trips. It allows uninterrupted safe operation of un-manned installations.

You can select which trips to reset, reset delay and maximum resets.

DC Brake

Electrically brakes high inertia loads. It increase productivity of machines such as band-saws

and chippers by reducing the time needed to replace saw bands or cutting heads. The starter pulses the DC over all three phases and does not require an external contactor.

24 VDC Output

Provides an in-built 24 VDC auxiliary power supply, removing the cost of a separate supply.

Jog

Run the motor at part speed (approx 11%). The maximum torque is approx 60% of motor FLT in forward and 45% FLT in reverse.

Ideal to position loads such as mixers or hopper bins ready for unloading

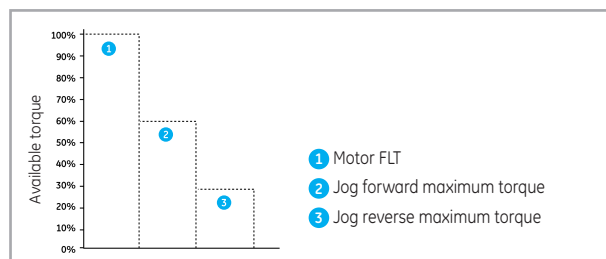

UL Compliance: Terminal/Connector Parts

For models QLxxB145D~QLxxB425D and QLxxX255D~QLxxX1K6D to be UL compliant, you must use the recommended pressure terminal/connector as detailed in the table below.

Model	FLC (A)	No. of wires	Recommended lugs part No.
QLxxB145D	145	1	OPHD 95-16
QLxxB170D	170	1	OPHD 120-16
QLxxB200D	200	1	OPHD 150-16
QLxxB220D	220	1	OPHD 185-16
QLxxB255D	255	1	OPHD 240-20
QLxxB350D	350	1	OPHD 400-16
QLxxB425D	425	2	OPHD 185-16
QLxxX255D	255	1	OPHD 240-20
QLxxX360D	360		
QLxxX380D	380		
QLxxX430D	430	2	1 x 600T-2
QLxxX620D	620		
QLxxX650D	650		
QLxxX790D	790	4	2 x 600T-2
QLxxX930D	930	3	2 x 600T-2
QLxxX1K2D	1200		
QLxxX1K4D	1410	4	1 x 750T-4
QLxxX1K6D	1600	5	1 x 750T-4 and 1 x 600T-3



ASTAT XB - XBm - XL

Basic wiring diagrams

- 1 x programmable input where you can connect transducers and probes, simpler control circuits and lower installation cost.
- 3 x remote digital inputs
- 3 x programmable outputs
- 1 x Analog output

Adjustable Busbars

Cabling or busbar work for higher power installations can be costly and require significant panel space. ASTAT XL soft starters ≥ 360 A reduce cable costs and panel space requirements because they allow for top or bottom connection of both input and output cabling.

Easy access of Control terminals

Pluggable terminal blocks make wiring easy. Separate terminal blocks for control and I/O ensure tidier wiring.



Schematic diagrams

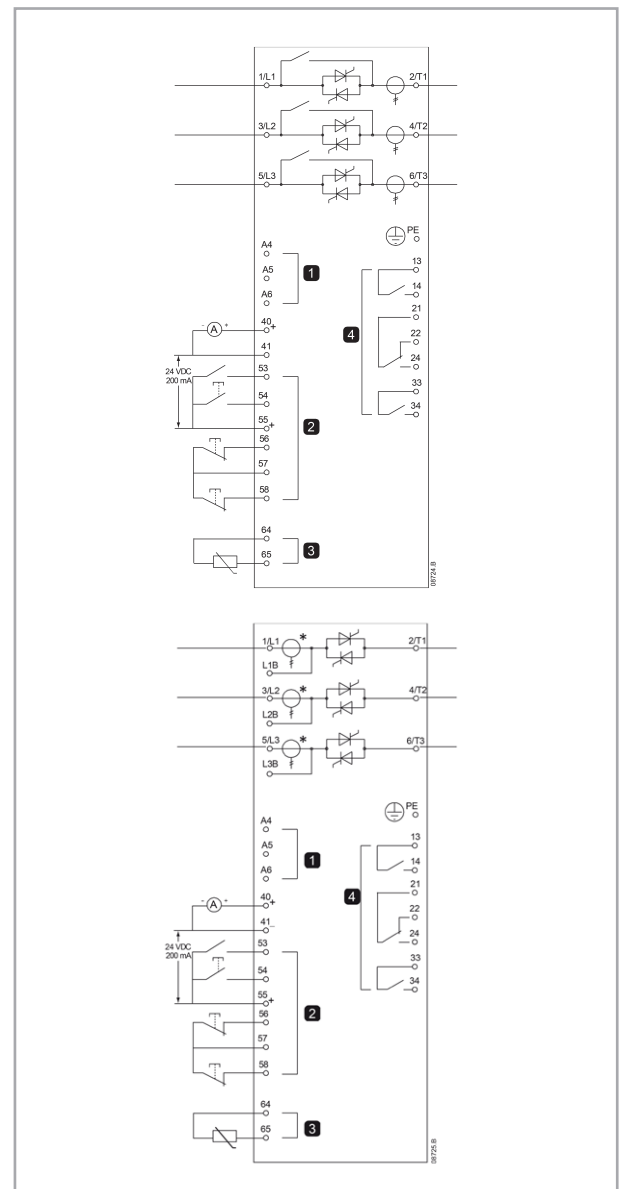

1	Control voltage (model dependent)
2	Remote control inputs
3	Motor thermistor input
4	Relay outputs
40, 41	Analog output
55, 41	24 VDC output
54, 55	Start
56, 57	Stop
58, 57	Reset
53, 55	Programmable input A
13, 14	Relay output A
21, 22, 24	Relay output B
33, 34	Relay output C

NOTE

Different models require control voltage to different terminals:

- 1 (110–120 VAC) A5, A6
- 1 (220–240 VAC) A4, A6
- 2 (24 VAC/VDC) A5, A6

NOTE

* QLxxX255D current transformers are located on the output. Bypass terminals are labelled T1B, T2B and T3B.



Control Panel

Full text language display

Metering screens
Trip diagnostics
Trip log
Event log

Shortcut keys

Performance logs and commissioning tools

Local control push-buttons

Status LEDs

Navigation buttons

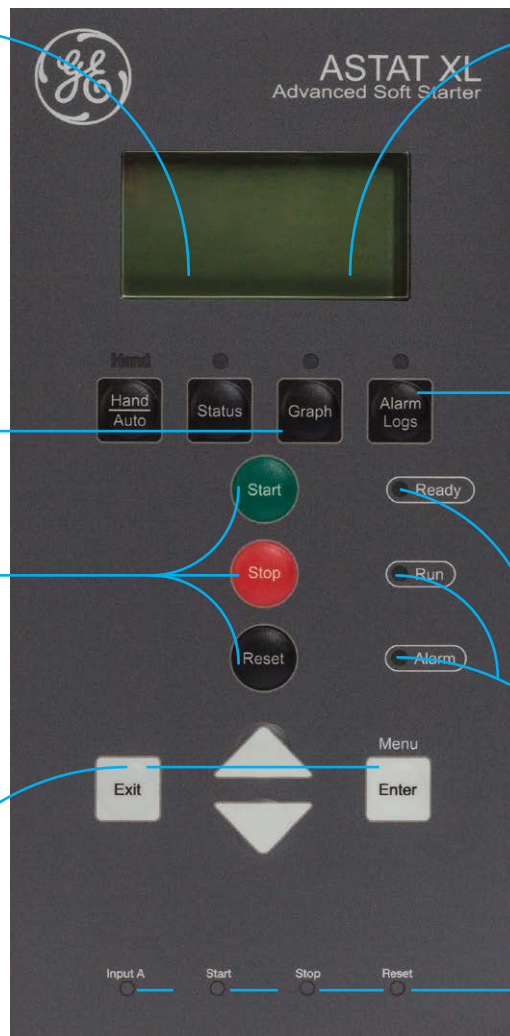

Quick Setup

1. Select your application
2. Starter suggests typical parameters and values
3. Review and adjust as required

Quick Setup		
Pump centrifugal ->	-> Pump centrifugal	
Pump submercible fan, damped Fan, undamped Compressor, screw Compressor, reciprocating Conveyor Crusher, rotary Chusher, jaw	Parameter Motor FLC Stat mode Adaptive Start Profile Start ramp time Stop mode Adaptive stop profile Stop time	Suggested value Model dependent Adaptive control Early acceleration 10 seconds Adaptive control Late decelartion 15 seconds



ASTAT XB - XBm - XL

Accessories XB - XBm

Remote Operator

(only for ASTAT XB and XBm) , QORCPXB , 872392

The remote operator controls and monitors motor performance via a communication module including:

- Operational control (start, stop, reset)
- Status monitoring (start, run and trip)
- Performance monitoring (motor current and temperature)
- Trip Code display
- 4-20mA analog output



Accessories XL

Remote Control Panel

Beside the control panel located on the soft starter ASTAT XL, it is possible to have a remote control panel that replicates display functionality and content, while operating in parallel. This control panel is hot removable and it has function the copycat function. Remote mountable keypad with IP65 and supplied with 3m cable



Common accessories XB - XBm - XL

Communication Modules

Supports USB and many network communication such as Profibus, Profinet, Ethernet, DeviceNet and Modbus RTU protocols, via an easy-to-install Plug & Play communication interface modules.



IP20 Protection Kit

This option ensures personnel safety by preventing accidental contact with live terminals. Provide IP20 protection when used with cable of diameter 22mm or greater.



ASTAT Setup Tool ed.3

With this new edition, exclusive for ASTAT XB, XBm and XL series, you can control and monitor your soft starter from your desktop computer.



			Intro
POWER DEVICES	Contactors and overload relays		B
	Auxiliary relays and contactors		B
	Motor protection devices		C
	Applications		D
AUXILIARY DEVICES	Main switches		E
	Control and signalling units		F
POWER ELECTRONICS	Speed drive units		G
	Soft starters		H
ENCLOSURES	Product overview		I
Enclosures overview	Alphabetical index		X
I.2	System Enclosures / Distribution Boards		
I.3	General Purpose Enclosures		





VMS

Modular enclosures system
 Modular enclosures of glass-fibre reinforced polycarbonate.
 □ IP65 - IK08
 According to EN/IEC 61439-2
 Rated current up to 1100A
 Modular dimensions in increments of 100 mm in height and width, in five sizes:

320 x 220 mm	640 x 320 mm
320 x 320 mm	640 x 440 mm
440 x 320 mm	



QuiXtra* 630

Low voltage distribution board for commercial and industrial environments.
 □ IP43
 According to IEC 61439-2
 Range of 24 different enclosures:
 9 heights, from 450 up to 1800 mm
 3 widths: 364, 660 and 876 mm
 1 depth: 250 mm
 Rated operational voltage: 415V
 Rated current up to 630A



QuiXtra* 4000

Low voltage distribution board for commercial and industrial environments.
 □ IP30 and IP55
 According to IEC 61439-2
 Range of 11 different enclosures:
 1 height, 2155 mm
 4 widths: 447, 600, 743 and 959 mm
 3 depths: 450, 600 and 800 mm
 Rated operational voltage: 415V, 690V
 Rated current up to 4000A



SEN Plus

A comprehensive range of low voltage switchgear applications:

- withdrawable and fixed power centres with air circuit breakers
- distribution panels with fully withdrawable or fixed versions for MCCBs and fuse switches
- motor control centres with fully withdrawable or fixed technique for fused/fuseless motor starter applications

General Purpose Enclosures



ARIA

Multipurpose polyester cabinets

☐ IP66 - IK08

UL - CSA - Lloyd's

7 sizes, from 315 x 215 x 170 mm up to 1035 x 835 x 300 mm.

Made out of glass-fibre reinforced polyester, RAL7035. Monobloc design.



PolySafe

Multipurpose polyester cabinets

☐ IP65/IP54 - IK10

UL - CSA - Lloyd's

14 standard dimensions, from 500 x 500 mm up to 1250 x 1000 mm.

One depth: 320 mm.

Made out of glass-fibre reinforced polyester, RAL7035. Panel design, without mold-in metal parts. Allows combination in height, width and depth



APO

Modular polyester boxes

☐ IP67 - IK08

UL - CSA - Lloyd's

9 basic enclosures from 185 x 150 x 130 mm up to 600 x 600 x 175 mm.

Greater depth is obtained by depth extension frames. Enclosures can be combined in height and width.



MultiBox

Small multipurpose boxes

☐ IP66 - IK07/08

11 basic sizes, from 65 x 65 mm up to 361 x 254 mm.

With 5 cover depths.

Made of polystyrene or glass-fibre reinforced polycarbonate.



EH

Cabinets for underground cable distribution.

More than 30 enclosures, in various configurations: DIN and non-DIN size, with double compartments, with increased depth, with front and rear doors. Providing solutions to various applications.



UC-Cabinet

Underground connection cabinet

5 standard configurations.

32A up to 125A outgoing ratings.

The diving bell principle prevents flood damage.



Everything is under control

			Intro
	POWER DEVICES	Contactors and overload relays	A
		Auxiliary relays and contactors	B
		Motor protection devices	C
		Applications	D
	AUXILIARY DEVICES	Main switches	E
		Control and signalling units	F
	POWER ELECTRONICS	Speed drive units	G
		Soft starters	H
	ENCLOSURES	Product overview	I
X.2	Controls Alphabetical Index		
X.20	Power Electronics Alphabetical Index	Alphabetical index	X



Controls Alphabetical Index

Alphabetical index

Cat. no.	Ref. no	Cat. pg	Cat. no.	Ref. no	Cat. pg	Cat. no.	Ref. no	Cat. pg	Cat. no.	Ref. no	Cat. pg
077-01	180033	F.55	077M2T2TV44	180923	F.50	077SP20SFE	180547	F.56	080SP4MSFE	170851	F.56
077-01R	180008	F.55	077M4S4X8B8	180926	F.50	077SP25	180533	F.56	080SP4SFE	170850	F.56
0770MT1234S	180315		077MAS4TX8B	180929	F.50	077SP25SFE	180548	F.56	080SP6	170806	F.56
0770P	180318		077M4S4TX8B8	181019	F.50	077SP2M	180524	F.56	080SP6SFE	170852	F.56
0770P2	181570		077M4S4TY8B	180933	F.50	077SP2MSFE	180539	F.56	080SP8	170807	F.56
077-10	180002	F.55	077M4T4TX8B	180927	F.50	077SP2SFE	180538	F.56	080SP8SFC	170855	F.56
077-10A	180007	F.55	077M4T4TY8B	180931	F.50	077SP3	180525	F.56	080SP8SFC	170853	F.56
077-11	180001	F.55	077M4T4TY8B8	181021	F.50	077SP30	180534	F.56	080SP8SFE	170854	F.56
077550N	213699		077MISB	181157	F.52	077SP36	180535	F.56	080XTG8	179515	F.36
077BMM	200205		077MISG	181153	F.52	077SP36SF	180554	F.56	080XTG801	179535	F.36
077C3095	173095	F.35	077MISR	181151	F.52	077SP36SFC	180552	F.56	080XTG802	179536	F.36
077C9901	179901	F.35	077MISV	181152	F.52	077SP36SFE	180550	F.56	080XTG803	179511	F.36
077C9902	179902	F.35	077MT1234S22	180915	F.50	077SP3SFE	180540	F.56	080XTG804	179537	F.36
077C9903	179903	F.35	077MT1234S22B	181005	F.50	077SP4	180527	F.56	080XTG805	179538	F.36
077C9904	179904	F.35	077MT1234S22HD	200238	F.50	077SP4SFE	180542	F.56	080XTG806	179539	F.36
077C9905	179905	F.35	077MT1234S22	180916	F.50	077SP4V	180526	F.56	080XTG807	179540	F.36
077C9910	179910	F.35	077MT1234S422B	181006	F.50	077SP4VSF	180553	F.56	080XTG807	179540	F.36
077CF73033	173033	F.35	077MT1234S422HD	200239	F.50	077SP4VSFC	180551	F.56	080XTGR	179514	F.36
077CF73034	173034	F.35	077MT234S122	180917	F.50	077SP4VSFE	180541	F.56	080XTGR01	179525	F.36
077CF73037	173037	F.35	077MT234S122HD	200240	F.50	077SP6	180528	F.56	080XTGR02	179526	F.36
077CF73038	173038	F.35	077MT24S22	180911	F.50	077SP6SFE	180543	F.56	080XTGR03	179510	F.36
077CF73040	173040	F.35	077MT24S22B	181001	F.50	077SP9	180529	F.56	080XTGR04	179527	F.36
077CM	200212		077MT24S22HD	200243	F.50	077SP9SFE	180544	F.56	080XTGR05	179528	F.36
077CPG	181583	F.54	077MT24S22R	180913	F.50	077SP9SFE	180544	F.56	080XTGR06	179529	F.36
077CPLT	181600	F.54	077MT24S22RB	181003	F.50	077SUN22	180440		080XTGR07	179530	F.36
077CPN	181580	F.54	077MTS123422	180914	F.50	077SUN22	180220		080XTGR08	179531	F.36
077CPR	181581	F.54	077MTS123422B	181004	F.50	077SUN22	180480		099SPDDB	180009	F.55
077CPT	181588	F.54	077MTS123422HD	200244	F.50	077SUN22	180510		105 CI	132242	F.63
077CPV	181582	F.54	077MTS2422	180910	F.50	077TGR02	181722	F.55	105 CI 10	132243	F.63
077CST	181603	F.54	077MTS2422B	181000	F.50	077TGR02	181722	F.55	105 GIL	132240	F.63
077DAE	181554	F.54	077MTS2422HD	200246	F.50	077TNA	181650	F.55	105 GIL 10	132241	F.63
077DAMP	181557		077MTS2422R	180912	F.50	077TNA02	200298	F.55	105 PM	132244	F.63
077DAMPGR20	242430		077MTS2422RB	181002	F.50	077TNA2	181660	F.55	105 PT	132234	F.62
077DAMPGR20	215373		077MTS2422RG	180935	F.50	077TNA22	200331	F.55	105DTL220	132230	F.62
077DLE14	181260		077P01	180039	F.46	077TNA3	181670	F.55	105DTL500	132231	F.62
077DPP	181550	F.54	077P10	180029	F.46	077TNA302	200340	F.55	105DTL690	132232	F.62
077E01	180069	F.47	077P11	180019	F.46	077TNA40	181840	F.55	105GP1P220	132250	F.62
077E10	180059	F.47	077PC11C	180100	F.47	077TPF	181601	F.54	105GP1P220M	132251	F.62
077E11	180049	F.47	077PC11G	180104	F.47	080CPDT	173208	F.15	105GP1P500	132252	F.62
077EER	181602		077PLM02D0	181042	F.51	080CPG	170193	F.21	105GP1P500M	132253	F.62
077EEG	180083		077PLM10D0	181043	F.51	080CPN	170190	F.21	114FCT03	130320	F.62
077EEN	180080		077PLM11D0	181040	F.51	080CPR	170191	F.21	114FCT03T	130321	F.62
077EER	180081		077PLM11TJ	181049	F.51	080CPT	170198	F.21	BA95110LEDB	187180	F.11
077EEV	180082		077PLM11TN	181050	F.51	080CPV	170192	F.21	BA95110LEDG	187181	F.11
077EG	180073		077PLM20D0	181041	F.51	080ESL	170212	F.34	BA95110LEDL	187182	F.11
077EN	180070		077PLM20D0	181041	F.51	080KCSF	170883	F.31	BA95110LEDL	187183	F.11
077ER	180071		077PPM	200260	F.50	080QDF	173220	F.33	BA95110LEDV	187184	F.11
077EV	180072		077PN11G	180150	F.50	080QDF001	187715	F.33	BA95122	187852	F.14
077GDLVB	181287		077PR11G	180151	F.50	080QDF002	187716	F.33	BA9512LEDB	187165	F.11
077GDLVG	181283		077PTB01	181609	F.55	080QDF006	187705	F.33	BA9512LEDG	187166	F.11
077GDLVR	181281		077PTB10	181608	F.55	080QDF017	187709	F.33	BA9512LEDL	187167	F.11
077GDLVW	181282		077PTB11	181615	F.55	080QDF018	187710	F.33	BA9512LEDR	187168	F.11
077GE35	181620	F.54	077PV11G	180152	F.50	080QDF026	187711	F.33	BA9512LEDV	187169	F.11
077GEBN	180030		077RE01	180099	F.47	080QDF027	187788	F.33	BA95130	187857	F.14
077GELG	180973	F.51	077RE10	180089	F.47	080QDF028	187702	F.33	BA95130LEDB	187190	F.11
077GELR	180971	F.51	077RE11	180079	F.47	080QDF029	187701	F.33	BA95160	187867	F.14
077GG03	180980	F.51	077RER	180090	F.47	080QDF030	187789	F.33	BA95220	187868	F.14
077GGBCF	180137	F.46	077SBN11	180230	F.48	080QDF031	187713	F.33	BA95230LB	187925	F.14
077GGBCN	180020	F.46	077SBN11DC	180250	F.48	080QDF032	187714	F.33	BA95230LEDB	187185	F.11
077GGBCS	180050	F.46	077SBN11RC	180260	F.48	080QDF201	187719	F.33	BA95230LEDG	187186	F.11
077GGM	180981	F.51	077SBN11SC	180240	F.48	080QDF202	187720	F.33	BA95230LEDL	187187	F.11
077GGT	180982	F.51	077SCB1120	180846	F.49	080SP1	170801	F.31	BA95230LEDR	187188	F.11
077GLA	181405	F.53	077SCB11DC07	180852	F.49	080SP12	170808	F.56	BA95230LEDV	187189	F.11
077GLB	181407	F.53	077SCH11RC03	180853	F.49	080SP12SF	170858	F.56	BA95230LR	187921	F.14
077GLBL	181406	F.53	077SCD1101	180630	F.49	080SP12SFC	170856	F.56	BA9524	187864	F.14
077GLG	181403	F.53	077SCD1105	180631	F.49	080SP12SFE	170857	F.56	BA95242	187853	F.14
077GLI	181408	F.53	077SCD1109	180632	F.49	080SP18	170809	F.56	BA9524LEDB	187170	F.11
077GLR	181401	F.53	077SCH11SC03	180636	F.49	080SP18SF	170861	F.56	BA9524LEDG	187171	F.11
077GLV	181402	F.53	077SCI110C03	180640	F.49	080SP18SFC	170859	F.56	BA9524LEDL	187172	F.11
077GPLB	180967	F.51	077SCI11D0C03	180640	F.49	080SP1M	170831	F.56	BA9524LEDR	187173	F.11
077GPLBL	180966	F.51	077SCU2220	180888	F.48	080SP1MSF	170840	F.56	BA9524LEDV	187174	F.11
077GPLG	180963	F.51	077SC2220C01	180902	F.48	080SP1MSFC	170838	F.56	BA9530	187854	F.14
077GPLI	180968	F.51	077SDN11	180170	F.48	080SP1MSF	170839	F.56	BA9530	187855	F.14
077GPLR	180961	F.51	077SHN11	180180	F.48	080SP1SF	170837	F.56	BA95348	187855	F.14
077GPLV	180962	F.51	077SHN11	180180	F.48	080SP1SFC	170835	F.56	BA95348LEDB	187175	F.11
077GSBCF	180136	F.46	077SLB11	180607	F.48	080SP1SFE	170836	F.56	BA95348LEDL	187177	F.11
077GSBCN	180010	F.46	077SLB11DC	180609	F.48	080SP2	170802	F.56	BA95348LEDR	187178	F.11
077GSBCS	180040	F.46	077SLB11RC	180610	F.48	080SP24	170810	F.56	BA95348LEDV	187179	F.11
077ISB11D0	181170	F.52	077SLB11SC	180608	F.48	080SP24SFE	170862	F.56	BA956012	187856	F.14
077ISB11D0RC	181174	F.52	077SLD11	180601	F.48	080SP2M	170832	F.56	BA95606	187850	F.14
077ISD11D0	181060	F.52	077SLI11	180604	F.48	080SP2MSF	170846	F.56	BA9560LEDB	187191	F.11
077ISZ11D0RC	181176	F.52	077SLU22	180619	F.48	080SP2MSFC	170844	F.56	BA95615	187851	F.14
077LDMVD	181305	F.53	077SLX22	180606	F.48	080SP2MSFE	170845	F.56	BA956LEDB	187160	F.11
077LDNV0	181300	F.53	077SLZ22	180623	F.48	080SP2SF	170843	F.56	BA956LEDG	187161	F.11
077LRNVJ	181301	F.53	077SLZ22DC	180625	F.48	080SP2SFC	170841	F.56	BA956LEDL	187162	F.11
077LRNVN	181302	F.53	077SLZ22RC	180626	F.48	080SP2SFE	170842	F.56	BA956LEDR	187163	F.11
077LTMVJ	181311	F.53	077SM	215334		080SP3	170803	F.56	BA956LEDV	187164	F.11
077LTMVN	181312	F.53	077SP1	180521	F.56	080SP35	170811	F.56	BA956LEDB	187165	F.11
077LTNVJ	181306	F.53	077SP12	180530	F.56	080SP35SF	170865	F.56	BA95N110	187860	F.14
077LTNVN	181307	F.53	077SP12SFE	180545	F.56	080SP35SFC	170863	F.56	BA95N220	187861	F.14
077M2S2SX44	180918	F.50	077SP16	180531	F.56	080SP35SFE	170864	F.56	BCLF01	104701	A.44
077M2S2SX44B	181008	F.50	077SP1M	180522	F.56	080SP3SFE	170849	F.56	BCLF01G	104703	A.44
077M2S2TX44	180921	F.50	077SP1MSFE	180537	F.56	080SP3SF	170849	F.56	BCLF01MP	108155	A.44
077M2T2TX44	180919	F.50	077SP1SFE	180536	F.56	080SP3SFC	170847	F.56	BCLF10	104700	A.44
077M2T2TX44B	181009	F.50	077SP2	180523	F.56	080SP3SFE	170848	F.5			

Controls Alphabetical Index

Cat. no.	Ref. no	Cat. pg	Cat. no.	Ref. no	Cat. pg	Cat. no.	Ref. no	Cat. pg	Cat. no.	Ref. no	Cat. pg
BCLL11	104707	A.44	CK10CE411W100-250	246200	A.50	CL00D301T	112018	A.42	CL01D301TT	112434	A.42
BCLL11GMP	108156	A.44	CK10CE411W24-60	246198	A.50	CL00D301TK	112413	A.42	CL01D301TWD	112035	A.42
BCLL11MP	248087	A.44	CK10CE411W250-500	246201	A.50	CL00D301TN	112019	A.42	CL01D301TWG	247935	A.42
BCLL20	104706	A.44	CK10CE411W48-130	246199	A.50	CL00D301TT	112416	A.42	CL01D301TWI	247012	A.42
BCRF01	108902	A.44	CK11CE311W100-250	246170	A.49	CL00D301TWD	112004	A.42	CL01D310RD	108897	A.42
BCRF10	108901	A.44	CK11CE311W24-60	246174	A.49	CL00D301TWE	101103	A.42	CL01D310TB	112020	A.42
BEKH	104763	A.51	CK11CE311W250-500	246177	A.49	CL00D301TWG	113142	A.42	CL01D310TD	112026	A.42
BEKV	104764	A.51	CK11CE311W48-130	246175	A.49	CL00D301TWJ	103909	A.42	CL01D310TDMP	202679	A.42
BEKVAG	133589	A.51	CK11CE411W100-250	246204	A.50	CL00D310RWD	112005	A.42	CL01D310TG	112027	A.42
BELA	104723	A.44	CK11CE411W24-60	246202	A.50	CL00D310RWI	137095	A.42	CL01D310TH	112420	A.42
BELA02	104724	A.44	CK11CE411W250-500	246205	A.50	CL00D310TB	112000	A.42	CL01D310TJ	112028	A.42
BETL02C	113602	A.45	CK11CE411W48-130	246203	A.50	CL00D310TD	112006	A.42	CL01D310TI	112422	A.42
BETL02D	113604	A.45	CK12BE311W100-250	246180	A.49	CL00D310TDMP	136129	A.42	CL01D310TN	112029	A.42
BETL45C	113603	A.45	CK12BE311W24-60	246178	A.49	CL00D310TG	112007	A.42	CL01D310TT	112425	A.42
BETL45D	113605	A.45	CK12BE311W250-500	246181	A.49	CL00D310TH	112402	A.42	CL01D310TWD	113511	A.42
BMLF	104800	A.46	CK12BE311W48-130	246179	A.49	CL00D310TJ	112008	A.42	CL01D310TWE	113435	A.42
BNL	104797	A.46	CK12BE411W100-250	246208	A.50	CL00D310TK	112404	A.42	CL01D310TWG	113448	A.42
BRLL02	106622	A.44	CK12BE411W24-60	246206	A.50	CL00D310TN	112009	A.42	CL01D310TWI	247014	A.42
BRLL11	104705	A.44	CK12BE411W250-500	246209	A.50	CL00D310TT	112407	A.42	CL01D310TWJ	113474	A.42
BRLL11G	133101	A.44	CK12BE411W48-130	246207	A.50	CL00D310TWD	113510	A.42	CL01D310TWN	113487	A.42
BRLL11J	133900	A.44	CK13BA311J	104523	A.49	CL00D310TWE	249901	A.42	CL01D400RWD	101186	A.43
BRLL20	104704	A.44	CK13BA311N	104524	A.49	CL00D310TWG	113203	A.42	CL01D400TB	112170	A.43
BSLDZ	104719	A.45	CK13BA311U	104525	A.49	CL00D310TWI	113460	A.42	CL01D400TD	112176	A.43
BSLR2G	104713	A.45	CK13BA311Y	104526	A.49	CL00D310TWJ	113473	A.42	CL01D400TG	112177	A.43
BSLR2K	104714	A.45	CK13BA411J	104603	A.50	CL00D310TWK	247756	A.42	CL01D400TH	112514	A.43
BSLR2R	104715	A.45	CK13BA411N	104604	A.50	CL00D310TWN	113486	A.42	CL01D400TJ	112178	A.43
BSLR3G	104716	A.51	CK13BA411U	104605	A.50	CL01A301R3	110570	A.42	CL01D400TK	112516	A.43
BSLR3K	104717	A.51	CK13GA322J	133522	A.49	CL01A301R6	108781	A.42	CL01D400TN	112179	A.43
BSLR3R	104718	A.51	CK75CA3111	247090	A.49	CL01A301T1	109268	A.42	CL01D400TWD	112175	A.43
BSLV3G	104720	A.51	CK75CA311D	113101	A.49	CL01A301T2	109269	A.42	CL01D400TWE	101107	A.43
BSLV3K	104721	A.51	CK75CA311J	113103	A.49	CL01A301T3MP	247856	A.42	CL01D400TWI	101108	A.43
BSLV3R	104722	A.51	CK75CA311M	133219	A.49	CL01A301T6	109274	A.42	CL01D400TJW	108802	A.43
BTLF30C	104709	A.44	CK75CA311N	133188	A.49	CL01A301R7	109275	A.42	CL01DB00RWD	101185	A.43
BTLF30D	104711	A.44	CK75CA311R	113893	A.49	CL01A301T9	113987	A.42	CL01DB00RWDJ	101189	A.43
BTLF60C	104710	A.44	CK75CA311U	113105	A.49	CL01A301TE	109253	A.42	CL01DB00TB	112240	A.43
BTLF60D	104712	A.44	CK75CA311Y	113122	A.49	CL01A301TJ	104093	A.42	CL01DB00TD	112246	A.43
BTRF30C	108903	A.44	CK75CE311W100-250	246152	A.49	CL01A301TK	109257	A.42	CL01DB00TG	112247	A.43
BTRF30D	108905	A.44	CK75CE311W24-60	246150	A.49	CL01A301TL	109258	A.42	CL01DB00TH	112248	A.43
BTRF60C	108904	A.44	CK75CE311W250-500	246153	A.49	CL01A301TN	104094	A.42	CL01DB00TK	112585	A.43
BTRF60D	108906	A.44	CK75CE311W48-130	246151	A.49	CL01A301TU	104095	A.42	CL01DB00TN	112249	A.43
C04255D	104811	A.50	CK75FXSP	103747	A.49	CL01A301TW	109264	A.42	CL01DB00TT	112588	A.43
C04255G	104812	A.50	CK85BA3116	110265	A.49	CL01A310JU	116765	A.42	CL01DB00TWD	112245	A.43
C04255J	104813	A.50	CK85BA311J	104473	A.49	CL01A310R3	110569	A.42	CL01DB00TWG	101192	A.43
C04255N	104814	A.50	CK85BA311U	104475	A.49	CL01A310R6	107241	A.42	CL02A301R6	108782	A.42
C04255U	104815	A.50	CK85BA311Y	101048	A.49	CL01A310R6MP	249149	A.42	CL02A301T1	109341	A.42
C04787D	104821	A.50	CK85BE311W100-250	246160	A.49	CL01A310RGN	136355	A.42	CL02A301T2	109342	A.42
C04787G	104822	A.50	CK85BE311W24-60	246158	A.49	CL01A310T1	109244	A.42	CL02A301T3MP	247857	A.42
C04787J	104823	A.50	CK85BE311W250-500	246161	A.49	CL01A310T2	109245	A.42	CL02A301T6	109346	A.42
C04787N	104824	A.50	CK85BE311W48-130	246159	A.49	CL01A310T4	109247	A.42	CL02A301T6MP	247960	A.42
C04787U	104825	A.50	CK95BE311W100-250	246168	A.49	CL01A310T6	109249	A.42	CL02A301T7	109347	A.42
C08998J	104833	A.50	CK95BE311W24-60	246166	A.49	CL01A310T7	109250	A.42	CL02A301T9	113986	A.42
C08998N	104834	A.50	CK95BE311W250-500	246169	A.49	CL01A310T8	109251	A.42	CL02A301TJ	104123	A.42
C08998U	104835	A.50	CK95BE311W48-130	246167	A.49	CL01A310T9	104067	A.42	CL02A301TK	109330	A.42
C12168T	101060	A.50	CK95BE411W100-250	246196	A.50	CL01A310TJ	104083	A.42	CL02A301TL	109331	A.42
CK07BA411J	104533	A.50	CK95BE411W24-60	246194	A.50	CL01A310TJMP	113209	A.42	CL02A301TN	104124	A.42
CK07BA411N	104534	A.50	CK95BE411W250-500	246197	A.50	CL01A310TK	109233	A.42	CL02A301TU	104125	A.42
CK07BA411R	110332	A.50	CK95BE411W48-130	246195	A.50	CL01A310TL	109234	A.42	CL02A301TW	109337	A.42
CK07BA411U	104535	A.50	CKX04	105201	A.42	CL01A310TN	104084	A.42	CL02A310R6	107242	A.42
CK07BA411Y	110337	A.50	CL00A301R3	110566	A.42	CL01A310TNMP	113207	A.42	CL02A310R7	100672	A.42
CK07BE411W100-250	246184	A.50	CL00A301T1	109197	A.42	CL01A310TU	104085	A.42	CL02A310RGN	136357	A.42
CK07BE411W24-60	246182	A.50	CL00A301T2	109198	A.42	CL01A310TW	109240	A.42	CL02A310T1	109317	A.42
CK07BE411W250-500	246185	A.50	CL00A301T6	109202	A.42	CL01A310TY	109242	A.42	CL02A310T1MP	114238	A.42
CK07BE411W48-130	246183	A.50	CL00A301T7	109203	A.42	CL01A400R1	110580	A.43	CL02A310T2	109318	A.42
CK08BA411J	104543	A.50	CL00A301T9	113982	A.42	CL01A400R5	108540	A.43	CL02A310T31	202678	A.42
CK08BA411N	104544	A.50	CL00A301TE	109182	A.42	CL01A400T1	110600	A.43	CL02A310T4	109320	A.42
CK08BA411R	110350	A.50	CL00A301TJ	104063	A.42	CL01A400T2	110601	A.43	CL02A310T6	109322	A.42
CK08BA411U	104545	A.50	CL00A301TK	109186	A.42	CL01A400T6	110605	A.43	CL02A310T7	109323	A.42
CK08BE411W100-250	246188	A.50	CL00A301TL	109187	A.42	CL01A400T7	110606	A.43	CL02A310T8	109324	A.42
CK08BE411W24-60	246186	A.50	CL00A301TN	104064	A.42	CL01A400T9	113981	A.43	CL02A310T9	104069	A.42
CK08BE411W250-500	246189	A.50	CL00A301TU	104065	A.42	CL01A400TJ	104313	A.43	CL02A310TJ	104113	A.42
CK08BE411W48-130	246187	A.50	CL00A301TW	109193	A.42	CL01A400TK	109884	A.43	CL02A310TJMP	111590	A.42
CK08CA3111	248069	A.49	CL00A301TY	109195	A.42	CL01A400TL	109885	A.43	CL02A310TK	109306	A.42
CK08CA311J	113133	A.49	CL00A310R3	110567	A.42	CL01A400TN	104314	A.43	CL02A310TL	109307	A.42
CK08CA311M	111581	A.49	CL00A310R6	110568	A.42	CL01A400TU	104315	A.43	CL02A310TN	104114	A.42
CK08CA311N	133187	A.49	CL00A310T1	109173	A.42	CL01A400TW	109891	A.43	CL02A310TU	104115	A.42
CK08CA311R	113889	A.49	CL00A310T1MP	114237	A.42	CL01A400TY	109893	A.43	CL02A310TW	109313	A.42
CK08CA311U	113135	A.49	CL00A310T2	109174	A.42	CL01A400T3	100626	A.43	CL02A310TY	109315	A.42
CK08CA311Y	101047	A.49	CL00A310T4	109176	A.42	CL01A400TJ	101105	A.43	CL02A400J	137184	A.43
CK08CA311Z	110251	A.49	CL00A310T6	109178	A.42	CL01A800MJ	101106	A.43	CL02A400MJ	101109	A.43
CK08CE311W100-250	246156	A.49	CL00A310T6MP	114236	A.42	CL01AB00T1	110656	A.43	CL02A400R1	110581	A.43
CK08CE311W24-60	246154	A.49	CL00A310T7	109179	A.42	CL01AB00T2	110657	A.43	CL02A400T2	110608	A.43
CK08CE311W250-500	246157	A.49	CL00A310T8	109180	A.42	CL01AB00T6	110661	A.43	CL02A400T7	110609	A.43
CK08CE311W48-130	246155	A.49	CL00A310T9	104066	A.42	CL01AB00T7	110662	A.43	CL02A400T6	110613	A.43
CK09BE311W100-250	246164	A.49	CL00A310TE	109158	A.42	CL01AB00T9	113423	A.43	CL02A400T7	110614	A.43
CK09BE311W24-60	246162	A.49	CL00A310TH	109160	A.42	CL01AB00TJ	104383	A.43	CL02A400T9	113965	A.43
CK09BE311W250-500	246165	A.49	CL00A310TJ	104053	A.42	CL01AB00TK	110059	A.43	CL02A400TF	109897	A.43
CK09BE311W48-130	246163	A.49	CL00A310TK	109162	A.42	CL01AB00TL	110060	A.43	CL02A400TH	104323	A.43
CK09BE411W100-250	246192	A.50	CL00A310TL	109163	A.42	CL01AB00TN	104384	A.43	CL02A400TL	109901	A.43
CK09BE411W24-60	246190	A.50	CL00A310TN	104054	A.42	CL01AB00TU	104385	A.43	CL02A400TN	104324	A.43
CK09BE411W250-500	246193	A.50	CL00A310TU	104055	A.42	CL01D301TD					

Controls Alphabetical Index

Cat. no.	Ref. no	Cat. pg	Cat. no.	Ref. no	Cat. pg	Cat. no.	Ref. no	Cat. pg	Cat. no.	Ref. no	Cat. pg
CL02AA00TL	104296	A.43	CL03A300TN	103943	A.42	CL04A300MN	104164	A.42	CL04D400MWG	103836	A.43
CL02AA00TN	104297	A.43	CL03A300TU	103972	A.42	CL04A301M1	109485	A.42	CL04D400MWI	201553	A.43
CL02AA00TU	104300	A.43	CL03A300TW	104000	A.42	CL04A301M2	109486	A.42	CL04D400MWJ	112542	A.43
CL02AB00MJ	101116	A.43	CL03A300TY	104019	A.42	CL04A301M3MP	247858	A.42	CL04D400MWN	101434	A.43
CL02AB00RN	110557	A.43	CL03A301M3MP	107262	A.42	CL04A301M6	109490	A.42	CL04D400MWT	248078	A.43
CL02AB00T1	110664	A.43	CL03A301M6	109418	A.42	CL04A301M7	109491	A.42	CL04D400RWG	204697	A.43
CL02AB00T2	110665	A.43	CL03A301M7	109419	A.42	CL04A301M9	104087	A.42	CL04D400RWI	247936	A.43
CL02AB00T6	110669	A.43	CL03A301M9	113985	A.42	CL04A301MD	104181	A.42	CL04D800MB	112270	A.43
CL02AB00T7	110670	A.43	CL03A310J1	125611	A.42	CL04A301MJ	104183	A.42	CL04D800MD	112276	A.43
CL02AB00T9	108235	A.43	CL03A310J2	125567	A.42	CL04A301ML	109475	A.42	CL04D800MG	112277	A.43
CL02AB00TJ	142231	A.43	CL03A310M1	109389	A.42	CL04A301MN	104184	A.42	CL04D800MJ	112278	A.43
CL02AB00TL	110076	A.43	CL03A310MJ	104143	A.42	CL04A301MU	104185	A.42	CL04D800MK	112612	A.43
CL02AB00TN	104394	A.43	CL03A310MN	104144	A.42	CL04A301MW	109481	A.42	CL04D800MN	112279	A.43
CL02AB00TU	104395	A.43	CL03A310R5	103637	A.42	CL04A301R5	103654	A.42	CL04D800MWG	204696	A.43
CL02AB00TY	110084	A.43	CL03A310R9	100659	A.42	CL04A301RN	103652	A.42	CL04D800RWD	112280	A.43
CL02D301RWG	103883	A.42	CL03A400J1	125665	A.43	CL04A301JL	116773	A.42	CL04D800RWG	204698	A.43
CL02D301TB	112050	A.42	CL03A400M1	110616	A.43	CL04A310JS	125580	A.42	CL05A300M1	104139	A.42
CL02D301TD	112056	A.42	CL03A400M2	110617	A.43	CL05A310M1	109461	A.42	CL05A300M2	104160	A.42
CL02D301TH	112057	A.42	CL03A400M4	110619	A.43	CL04A310M2	109462	A.42	CL05A300M6	104188	A.42
CL02D301TG	112447	A.42	CL03A400M6	110621	A.43	CL04A310M4	109464	A.42	CL05A300M7	104189	A.42
CL02D301TJ	112058	A.42	CL03A400M7	110622	A.43	CL04A310M6	109466	A.42	CL05A300M9	104167	A.42
CL02D301TK	112449	A.42	CL03A400M9	104090	A.43	CL04A310M7	109467	A.42	CL05A300MJ	104169	A.42
CL02D301TN	112059	A.42	CL03A400MJ	104333	A.43	CL04A310M8	109468	A.42	CL05A300MK	104180	A.42
CL02D301TT	112452	A.42	CL03A400MN	104334	A.43	CL04A310M9	104088	A.42	CL05A300ML	104187	A.42
CL02D301TWD	107135	A.42	CL03A400MU	104335	A.43	CL04A310MJ	104173	A.42	CL05A300MN	104190	A.42
CL02D301TWE	101118	A.42	CL03A400MY	109925	A.43	CL04A310MJMP	136125	A.42	CL05A300MU	104196	A.42
CL02D301TWG	247444	A.42	CL03A400R1	110577	A.43	CL04A310MK	109450	A.42	CL05A300MY	104197	A.42
CL02D301TWI	101132	A.42	CL03AB00M1	110672	A.43	CL04A310ML	109451	A.42	CL05A311MN	104204	A.42
CL02D301TWK	202658	A.42	CL03AB00M2	110673	A.43	CL04A310MLMP	103975	A.42	CL05A400M1	110632	A.43
CL02D301TWN	202657	A.42	CL03AB00M4	110675	A.43	CL04A310MN	104174	A.42	CL05A400M2	110633	A.43
CL02D301TWT	202655	A.42	CL03AB00M6	110677	A.43	CL04A310MU	104175	A.42	CL05A400M6	110637	A.43
CL02D310RK	101165	A.42	CL03AB00M7	110678	A.43	CL04A310MW	109457	A.42	CL05A400M7	110638	A.43
CL02D310RWD	112043	A.42	CL03AB00M9	113424	A.43	CL04A310MY	109459	A.42	CL05A400M9	108233	A.43
CL02D310RWE	112052	A.42	CL03AB00MJ	104403	A.43	CL04A400M1	110624	A.43	CL05A400MJ	104353	A.43
CL02D310RWG	103879	A.42	CL03AB00MK	110091	A.43	CL04A400M2	110625	A.43	CL05A400ML	109949	A.43
CL02D310TB	112040	A.42	CL03AB00MN	104404	A.43	CL04A400M6	110629	A.43	CL05A400MN	104354	A.43
CL02D310TD	112046	A.42	CL03AB00MU	104405	A.43	CL04A400M7	110630	A.43	CL05A400MU	104355	A.43
CL02D310TDP	202680	A.42	CL03AB00MW	204857	A.43	CL04A400M9	104156	A.43	CL05A400R1	103660	A.43
CL02D310TG	112047	A.42	CL03D300TB	104030	A.42	CL04A400MJ	104343	A.43	CL05A400R5	103661	A.43
CL02D310TH	112438	A.42	CL03D300TD	104038	A.42	CL04A400MK	109932	A.43	CL05A400R8	103838	A.43
CL02D310TJ	112048	A.42	CL03D300TG	104039	A.42	CL04A400MN	104344	A.43	CL05A400RN	110688	A.43
CL02D310TJD	112071	A.42	CL03D300TH	202671	A.42	CL04A400MU	104345	A.43	CL05AB00M2	110689	A.43
CL02D310TK	112440	A.42	CL03D300TJ	104047	A.42	CL04A400M1	110680	A.43	CL05AB00M4	110691	A.43
CL02D310TN	112049	A.42	CL03D300TK	202667	A.42	CL04AB00M2	110681	A.43	CL05AB00M6	110693	A.43
CL02D310TR	112442	A.42	CL03D300TN	104127	A.42	CL04AB00M6	110685	A.43	CL05AB00M7	110694	A.43
CL02D310TT	112443	A.42	CL03D300TT	202666	A.42	CL04AB00M7	110686	A.43	CL05AB00M9	104250	A.43
CL02D310TWD	113512	A.42	CL03D300TWD	104068	A.42	CL04AB00M9	104236	A.43	CL05AB00MJ	104423	A.43
CL02D310TWE	113436	A.42	CL03D300TWE	104116	A.42	CL04AB00MJ	104413	A.43	CL05AB00MN	104424	A.43
CL02D310TWG	113449	A.42	CL03D300TWG	104070	A.42	CL04AB00MU	104414	A.43	CL05AB00MU	104425	A.43
CL02D310TWI	113462	A.42	CL03D300TWI	104080	A.42	CL04D300MB	112100	A.42	CL05D300MB	104198	A.42
CL02D310TWJ	113475	A.42	CL03D300TWJ	104107	A.42	CL04D301MB	112100	A.42	CL05D300MD	104199	A.42
CL02D310TWK	202660	A.42	CL03D300TWN	104126	A.42	CL04D301MD	112106	A.42	CL05D300MDMP	136128	A.42
CL02D310TWN	113488	A.42	CL03D301MD	112086	A.42	CL04D301MF	112105	A.42	CL05D300MG	104200	A.42
CL02D310TWT	202656	A.42	CL03D301MWI	201543	A.42	CL04D301MG	112107	A.42	CL05D300MH	104207	A.42
CL02D400RWD	110786	A.43	CL03D301RWE	103712	A.42	CL04D301MH	112492	A.42	CL05D300MJ	104209	A.42
CL02D400RWE	248082	A.43	CL03D301RWN	103714	A.42	CL04D301MJ	112108	A.42	CL05D300MK	104219	A.42
CL02D400TB	112180	A.43	CL03D301MD	112076	A.42	CL04D301MK	112494	A.42	CL05D300MN	104220	A.42
CL02D400TD	112186	A.43	CL03D301MG	112077	A.42	CL04D301MN	112109	A.42	CL05D300MT	104227	A.42
CL02D400TG	112187	A.43	CL03D301MWK	248188	A.42	CL04D301MWD	113379	A.42	CL05D300MWD	104228	A.42
CL02D400TJ	112188	A.43	CL03D301RWE	103705	A.42	CL04D301MWG	107009	A.42	CL05D300MWE	104239	A.42
CL02D400TK	112525	A.43	CL03D310RWN	103707	A.42	CL04D301MWI	201550	A.42	CL05D300MWG	104240	A.42
CL02D400TN	112189	A.43	CL03D400MB	112190	A.43	CL04D301MWW	103913	A.42	CL05D300MWI	104246	A.42
CL02D400TT	112528	A.43	CL03D400MD	112196	A.43	CL04D301RWE	103715	A.42	CL05D300MWJ	104247	A.42
CL02D400TWD	112041	A.43	CL03D400MG	112197	A.43	CL04D301RWG	103852	A.42	CL05D300MWN	104260	A.42
CL02D400TWG	112045	A.43	CL03D400MH	112532	A.43	CL04D301RWN	103717	A.42	CL05D400MD	111607	A.43
CL02D400TWJ	101190	A.43	CL03D400MJ	112198	A.43	CL04D310JD	112486	A.42	CL05D400MT	101435	A.43
CL02D400TWK	202664	A.43	CL03D400MK	112534	A.43	CL04D310MB	112090	A.42	CL05D400MWD	103802	A.43
CL02D400TWN	104816	A.43	CL03D400MN	112199	A.43	CL04D310MD	112096	A.42	CL05D400MWE	103694	A.43
CL02D400TWT	202662	A.43	CL03D400MT	112537	A.43	CL04D310MDMP	136126	A.42	CL05D400MWI	103837	A.43
CL02D800RWD	112251	A.43	CL03D400MWD	112191	A.43	CL04D310MG	112097	A.42	CL05D400MWJ	103695	A.43
CL02D800RWE	112252	A.43	CL03D400MWG	136123	A.43	CL04D310MH	112483	A.42	CL05D400MWN	103889	A.43
CL02D800TB	112250	A.43	CL03D400MWI	201547	A.43	CL04D310MI	112484	A.42	CL05D400MWT	248079	A.43
CL02D800TD	112256	A.43	CL03D400MWJ	112195	A.43	CL04D310MJ	112098	A.42	CL05D400RWD	103811	A.43
CL02D800TG	112257	A.43	CL03D400MWK	136120	A.43	CL04D310MK	112485	A.42	CL05D400RWE	103722	A.43
CL02D800TJ	112258	A.43	CL03D400MWN	136119	A.43	CL04D310MLG	112481	A.42	CL05D400RWJ	103723	A.43
CL02D800TK	112594	A.43	CL03D400MWT	248077	A.43	CL04D310ML	112099	A.42	CL05D400RWU	103724	A.43
CL02D800TN	112259	A.43	CL03D400RWJ	240888	A.43	CL04D310MT	112488	A.42	CL05D800MWJ	103932	A.43
CL02D800TWD	247008	A.43	CL03D800MB	112260	A.43	CL04D310MWD	113450	A.42	CL05D800MWN	111637	A.43
CL02D800TWG	200109	A.43	CL03D800MD	112266	A.43	CL04D310MWG	113451	A.42	CL05E400MD	112216	A.43
CL02D800TWI	200110	A.43	CL03D800MG	112267	A.43	CL04D310MWI	113464	A.42	CL05E400MJ	112218	A.43
CL02D800TWK	202663	A.43	CL03D800MH	112601	A.43	CL04D310MWJ	113477	A.42	CL05E400MN	112219	A.43
CL02D800TWN	200111	A.43	CL03D800MJ	112268	A.43	CL04D310MWK	248189	A.42	CL05E400MWD	112215	A.43
CL02D800TWT	202661	A.43	CL03D800MK	112603	A.43	CL04D310MWN	113490	A.42	CL05E400MWH	101576	A.43
CL03A300M5	109369	A.42	CL03D800MN	112269	A.43	CL04D310RWG	103844	A.42	CL05E400MWJ	101582	A.43
CL03A300T1	103923	A.42	CL03D800MT	112606	A.43	CL04D310RWN	103711	A.42	CL05E400MUU	101706	A.43
CL03A300T1MP	202670	A.42	CL03D800MWD	136124	A.43	CL04D400MB	112202	A.43	CL05E800MD	112286	A.43
CL03A300T2	103924	A.42	CL03D800MWG	247816	A.43	CL04D400MD	112201	A.43	CL05E800MJ	112288	A.43
CL03A300T6	103935	A.42	CL03D800MWG	136122	A.43	CL04D400MG	112207	A.43	CL05E800MU	112289	A.43
CL03A300T6MP	202672	A.42	CL03D800MWI	248112	A.43	CL04D400MH	112541	A.43	CL05E800MWD	101519	A.43
CL03A300T7	103936	A.42	CL03D800MWJ	136121	A.43	CL04D400MJ	112208	A.43	CL05E800MWH	101578	A.43
CL											

Controls Alphabetical Index

Cat. no.	Ref. no	Cat. pg	Cat. no.	Ref. no	Cat. pg	Cat. no.	Ref. no	Cat. pg	Cat. no.	Ref. no	Cat. pg
CL06A300MJ	104213	A.42	CL08A300M1	109652	A.42	CL09D300MWB	103680	A.42	CSCN12A3021	100962	D.35
CL06A300MK	101826	A.42	CL08A300M2	109653	A.42	CL09D300MWD	103681	A.42	CSCN12A3023	100963	D.35
CL06A300MN	104214	A.42	CL08A300M4	109655	A.42	CL09D300MWE	103682	A.42	CSCN12A3026	101702	D.35
CL06A300MU	104215	A.42	CL08A300M6	109657	A.42	CL09D300MWG	103683	A.42	CSCN12A3027	100965	D.35
CL06A300R1	100708	A.42	CL08A300M7	109658	A.42	CL09D300MWI	103684	A.42	CSCN12A302D	110910	D.35
CL06A300RS	103602	A.42	CL08A300M9	113396	A.42	CL09D300MWJ	103685	A.42	CSCN12A302J	110911	D.35
CL06D300MWD	103610	A.42	CL08A300MJ	104287	A.42	CL09D300MWN	103686	A.42	CSCN12A302N	110912	D.35
CL06D300RWF	103845	A.42	CL08A300MK	109641	A.42	CL09D300RWD	103820	A.42	CSCN12A302R	110913	D.35
CL06E300MD	112126	A.42	CL08A300ML	109642	A.42	CL09D300RWE	103821	A.42	CSCN12A311D	100966	D.35
CL06E300MWJ	113479	A.42	CL08A300MN	104254	A.42	CL09D300RWG	103863	A.42	CSCN12A311G	100967	D.35
CL06E311MN	113254	A.42	CL08A300MU	104255	A.42	CL09D300RWI	103864	A.42	CSCN12A311H	247219	D.35
CL07A300M1	109604	A.42	CL08A300MY	109650	A.42	CL09D300RWJ	103865	A.42	CSCN12A311I	247296	D.35
CL07A300M2	109605	A.42	CL08A300R1	100718	A.42	CL09D400MWD	103804	A.43	CSCN12A311J	100970	D.35
CL07A300M4	109607	A.42	CL08A300R3	103938	A.42	CL09D400MWE	103698	A.43	CSCN12A311K	110905	D.35
CL07A300M6	109609	A.42	CL08A300R5	103608	A.42	CL09D400MWJ	103699	A.43	CSCN12A311L	100417	D.35
CL07A300M7	109610	A.42	CL08A300R9	103606	A.42	CL09D400MWN	248070	A.43	CSCN12A311M	110906	D.35
CL07A300M9	108289	A.42	CL08A311MT	109670	A.42	CL09D400RWD	103822	A.43	CSCN12A311N	110970	D.35
CL07A300MJ	104233	A.42	CL08A400MU	103896	A.43	CL09D400RWE	103727	A.43	CSCN12A311O	110907	D.35
CL07A300MK	109593	A.42	CL08A800M1	110704	A.43	CL09D400RWI	247006	A.43	CSCN12A311P	247282	D.35
CL07A300ML	109594	A.42	CL08A800M2	110705	A.43	CL09D400RWJ	103728	A.43	CSCN12A311R	110908	D.35
CL07A300MN	104234	A.42	CL08A800M6	110709	A.43	CL09E300MD	112156	A.42	CSCN12A311T	106993	D.35
CL07A300MU	104235	A.42	CL08A800M7	110710	A.43	CL09E300MJ	112158	A.42	CSCN12A311U	247204	D.35
CL07A300MY	109602	A.42	CL08A800M9	104237	A.43	CL09E300MN	112159	A.42	CSCN12A311V	110909	D.35
CL07A300MZ	101436	A.42	CL08A800MJ	104443	A.43	CL09E300MWD	113519	A.42	CSCN12A311W	100972	D.35
CL07A300R3	100712	A.42	CL08A800MK	110154	A.43	CL09E300MWH	101517	A.42	CSCN12A3203	100976	D.35
CL07A311JJ	125584	A.42	CL08A800ML	110155	A.43	CL09E300MWJ	113482	A.42	CSCN12A3207	100978	D.35
CL07A320M1	242186	A.42	CL08A800MN	104444	A.43	CL09E300MWU	101630	A.42	CSCN12A320D	110900	D.35
CL07A400JJ	116766	A.43	CL08A800MU	104445	A.43	CL09E400MD	112236	A.43	CSCN12A320J	207571	D.35
CL07A400M1	110762	A.43	CL08A800MY	110163	A.43	CL09E400MJ	112238	A.43	CSCN12A320N	110902	D.35
CL07A400M6	110645	A.43	CL08D300MB	101438	A.42	CL09E400MN	112239	A.43	CSCN12A320R	110903	D.35
CL07A400M7	110646	A.43	CL08D300MWB	103673	A.42	CL09E400MWH	101518	A.43	CSCN12A320U	248173	D.35
CL07A400M9	108234	A.43	CL08D300MWD	103674	A.42	CL09E400MWJ	101584	A.43	CSCN16A3021	100979	D.35
CL07A400MJ	104363	A.43	CL08D300MWE	103675	A.42	CL09E400MWU	101783	A.43	CSCN16A3023	101528	D.35
CL07A400ML	109965	A.43	CL08D300MWG	103676	A.42	CL10A300M1	109748	A.42	CSCN16A3026	101703	D.35
CL07A400MN	104364	A.43	CL08D300MWI	103677	A.42	CL10A300M2	109749	A.42	CSCN16A3027	101530	D.35
CL07A400MU	104365	A.43	CL08D300MWJ	103678	A.42	CL10A300M4	109751	A.42	CSCN16A302D	110925	D.35
CL07A400MY	109973	A.43	CL08D300MWN	103679	A.42	CL10A300M6	109753	A.42	CSCN16A302J	110926	D.35
CL07A400R1	103662	A.43	CL08D300RWD	103815	A.42	CL10A300M7	109754	A.42	CSCN16A302N	110927	D.35
CL07A400R5	103663	A.43	CL08D300RWE	103816	A.42	CL10A300M9	108232	A.42	CSCN16A302R	110928	D.35
CL07A400R9	111614	A.43	CL08D300RWG	103860	A.42	CL10A300MJ	104293	A.42	CSCN16A311D	101531	D.35
CL07A800M1	110696	A.43	CL08D300RWI	103861	A.42	CL10A300MW	109737	A.42	CSCN16A311G	101532	D.35
CL07A800M6	110701	A.43	CL08D300RWJ	103817	A.42	CL10A300ML	109738	A.42	CSCN16A311H	247222	D.35
CL07A800M7	110702	A.43	CL08E300JJ	138173	A.42	CL10A300MN	104294	A.42	CSCN16A311I	101557	D.35
CL07A800M9	104238	A.43	CL08E300MD	112146	A.42	CL10A300MU	104295	A.42	CSCN16A311J	110920	D.35
CL07A800MG	104432	A.43	CL08E300MJ	112148	A.42	CL10A300MY	109746	A.42	CSCN16A311K	100418	D.35
CL07A800MJ	104433	A.43	CL08E300MN	112149	A.42	CL10A300R1	100732	A.42	CSCN16A311L	110921	D.35
CL07A800ML	110139	A.43	CL08E300MWD	113518	A.42	CL10A300R3	103940	A.42	CSCN16A311M	111593	D.35
CL07A800MN	104434	A.43	CL08E300MWH	113468	A.42	CL10A300RN	103623	A.42	CSCN16A311N	110922	D.35
CL07A800MU	104435	A.43	CL08E300MWJ	113481	A.42	CL10D300MB	104179	A.42	CSCN16A311NG	247284	D.35
CL07D300MB	101437	A.42	CL08E300MWU	101589	A.42	CL10D300MD	111633	A.42	CSCN16A311R	110923	D.35
CL07D300MD	111616	A.42	CL08E311MJ	113260	A.42	CL10D300MWD	103688	A.42	CSCN16A311U	247228	D.35
CL07D300MK	103904	A.42	CL08E311MN	113261	A.42	CL10D300MWE	103689	A.42	CSCN16A3201	101558	D.35
CL07D300MWB	103666	A.42	CL08E311MY	112860	A.42	CL10D300MWG	103690	A.42	CSCN16A3203	101559	D.35
CL07D300MWD	103667	A.42	CL08E800MD	112306	A.43	CL10D300MWI	103691	A.42	CSCN16A3207	101561	D.35
CL07D300MWE	103668	A.42	CL08E800MJ	112308	A.43	CL10D300MWJ	103692	A.42	CSCN16A320D	110915	D.35
CL07D300MWG	103669	A.42	CL08E800MN	112309	A.43	CL10D300MWN	103693	A.42	CSCN16A320J	110916	D.35
CL07D300MWI	103670	A.42	CL08E800MWD	101521	A.43	CL10D300RWD	103823	A.42	CSCN16A320N	110917	D.35
CL07D300MWJ	103671	A.42	CL08E800MWDG	247817	A.43	CL10D300RWE	103824	A.42	CSCN16A320R	110918	D.35
CL07D300MWN	103672	A.42	CL08E800MWH	101580	A.43	CL10D300RWG	103866	A.42	CSCN16A320W	110919	D.35
CL07D300RWD	110140	A.42	CL08E800MWJ	101587	A.43	CL10D300RWI	103867	A.42	CSCN20A3011	101562	D.35
CL07D300RWE	110773	A.42	CL08E800MWU	101813	A.43	CL10D300RWK	103893	A.42	CSCN20A3013	101563	D.35
CL07D300RWG	103857	A.42	CL09A300M1	109700	A.42	CL10E300MD	112166	A.42	CSCN20A3017	101565	D.35
CL07D300RWI	103858	A.42	CL09A300M13	112160	A.42	CL10E300MJ	112168	A.42	CSCN20A301D	110935	D.35
CL07D300RWJ	110774	A.42	CL09A300M2	109701	A.42	CL10E300MN	112169	A.42	CSCN20A301J	207572	D.35
CL07D400MWD	103803	A.43	CL09A300M4	109703	A.42	CL10E300MWD	113520	A.42	CSCN20A301N	110937	D.35
CL07D400MWE	103696	A.43	CL09A300M6	109705	A.42	CL10E300MWE	113444	A.42	CSCN20A301R	110938	D.35
CL07D400MWJ	103697	A.43	CL09A300M7	109706	A.42	CL10E300MWH	113470	A.42	CSCN20A301T	101566	D.35
CL07D400RWD	103851	A.43	CL09A300M9	104218	A.42	CL10E300MWJ	113483	A.42	CSCN20A3013	101567	D.35
CL07D400RWE	103725	A.43	CL09A300MD	101439	A.42	CL10E300MWU	101705	A.42	CSCN20A3107	101569	D.35
CL07D400RWJ	103726	A.43	CL09A300MJ	104273	A.42	CL10E311MJ	108975	A.42	CSCN20A310D	110930	D.35
CL07E300MWJ	111638	A.43	CL09A300MK	109689	A.42	CL10E311MN	113376	A.42	CSCN20A310J	207573	D.35
CL07E300MD	112136	A.42	CL09A300ML	109690	A.42	CLNAA310AT1	248122	D.66	CSCN20A310N	110932	D.35
CL07E300MJ	112138	A.42	CL09A300MN	104274	A.42	CLNAA310ATJ	248123	D.66	CSCN20A310NG	247285	D.35
CL07E300MN	112139	A.42	CL09A300MU	104275	A.42	CLNAA310ATS	248124	D.66	CSCN20A310R	110933	D.35
CL07E300MWD	113517	A.42	CL09A300MY	109698	A.42	CLNAA310ATU	248125	D.66	CSCN20A310T	106953	D.35
CL07E300MWH	101575	A.42	CL09A300MZ	101514	A.42	CLNBA310AT1	248126	D.66	CSCN20A310W	110934	D.35
CL07E300MWJ	113480	A.42	CL09A300R3	100728	A.42	CLNBA310ATJ	248127	D.66	CSCN20A3121	101570	D.35
CL07E300MWU	101516	A.42	CL09A300R5	100730	A.42	CLNBA310ATS	248128	D.66	CSCN20A3123	101571	D.35
CL07E311JJ	113373	A.42	CL09A311JJ	125589	A.42	CLNBA310ATU	248129	D.66	CSCN20A3126	207620	D.35
CL07E311MN	295148	A.42	CL09A311R11	125700	A.42	CLNCA310AM1	248130	D.66	CSCN20A3127	101574	D.35
CL07E400MD	112226	A.43	CL09A400M1	110648	A.43	CLNCA310AMJ	248131	D.66	CSCN20A312D	110945	D.35
CL07E400MJ	112228	A.43	CL09A400M2	110763	A.43	CLNCA310AMS	248132	D.66	CSCN20A312J	207575	D.35
CL07E400MN	112229	A.43	CL09A400M6	110653	A.43	CLNCA310AMU	248133	D.66	CSCN20A312M	110971	D.35
CL07E400MWD	112225	A.43	CL09A400M7	110654	A.43	CLNDA310AM1	248134	D.66	CSCN20A312N	110947	D.35
CL07E400MWJ	101577	A.43	CL09A400MJ	104373	A.43	CLNDA310AMJ	248135	D.66	CSCN20A312R	110948	D.35
CL07E400MWU	101583	A.43	CL09A400MK	109980	A.43	CLNDA310AMS	248136	D.66	CSCN20A312U	247229	D.35
CL07E400MWU	101718	A.43	CL09A400ML	109981	A.43	CLNDA310AMU	248137	D.66	CSCN20A3211	101590	D.35
CL07E800MD	112296	A.43	CL09A400MN	104374	A.43	CLNEA310AM1	248138	D.66	CSCN20A3213	101591	D.35
CL07E800MJ	112298	A.43	CL09A400MU	104375	A.43	CLNEA310AMJ	248139	D.66	CSCN20A3216	207576	D.35
CL07E800MN	112299	A.43	CL09A400R1	103684	A.43	CLNEA310AMS	248140	D.66	CSCN2		

Controls Alphabetical Index

Cat. no.	Ref. no	Cat. pg	Cat. no.	Ref. no	Cat. pg	Cat. no.	Ref. no	Cat. pg	Cat. no.	Ref. no	Cat. pg
CSCN20A321R	110943	D.35	CSCN70A301N	247233	D.35	D/660006-943	789231	E.5	EA07D310I024	248006	A.32
CSCN20A321U	247224	D.35	CSCN70A301U	247218	D.35	D/660007-712	789292	E.7	EA07D310I110	248008	A.32
CSCN25A3011	101595	D.35	CSCN70A3103	247200	D.35	D/660007-713	789297	E.7	EA07D310S024	247998	A.32
CSCN25A3013	101596	D.35	CSCN70A3106G	247300	D.35	D/660138-712	789322	E.7	EA07D310S110	248000	A.32
CSCN25A3016	247212	D.35	CSCN70A310J	207593	D.35	D/660138-713	789327	E.7	EC09A311B012	267001	A.20
CSCN25A3017	101598	D.35	CSCN70A310N	247234	D.35	D/660206-712	789302	E.7	EC09A311B024	267002	A.20
CSCN25A301D	110955	D.35	CSCN70A310NG	247294	D.35	D/660206-713	789307	E.7	EC09A311B042	267003	A.20
CSCN25A301J	207578	D.35	CSCN70A310U	247221	D.35	D/660207-712	789312	E.7	EC09A311B048	267004	A.20
CSCN25A301N	110957	D.35	CSCN70A3113	247158	D.35	D/660207-713	789317	E.7	EC09A311B110	267005	A.20
CSCN25A301R	110958	D.35	CSCN70A3116	207594	D.35	D/660238-712	789332	E.7	EC09A311B120	267006	A.32
CSCN25A3101	101599	D.35	CSCN70A3117	247201	D.35	D/660238-713	789337	E.7	EC09A311B208	267007	A.32
CSCN25A3103	101600	D.35	CSCN70A311N	247232	D.35	D/670000-007	789273	E.6	EC09A311B230	267008	A.32
CSCN25A3106	247223	D.35	CSCN70A311NG	247295	D.35	D/670000-201	789246	E.6	EC09A311B240	267009	A.32
CSCN25A3107	101602	D.35	CSCN70A311W	247277	D.35	D/670000-202	789252	E.6	EC09A311B400	267010	A.32
CSCN25A310D	109590	D.35	CSCN70A3126	247206	D.35	D/670000-203	789258	E.6	EC09A311B440	267011	A.32
CSCN25A310J	207579	D.35	CSCN70A3127	247202	D.35	D/670000-204	789264	E.6	EC09A311B480	267012	A.32
CSCN25A310N	110952	D.35	CSCN70A312N	247159	D.35	D/670000-301	789247	E.6	EC09A311B500	267013	A.32
CSCN25A310NG	247286	D.35	D/640006-112	789178	E.4	D/670000-302	789253	E.6	EC09A311B600	267014	A.32
CSCN25A310R	110953	D.35	D/640006-113	789180	E.4	D/670000-303	789259	E.6	EC09D311B012W	267085	A.32
CSCN25A310U	247226	D.35	D/640006-142	789174	E.4	D/670000-304	789265	E.6	EC09D311B024L	267096	A.32
CSCN25A310W	110954	D.35	D/640006-143	789176	E.4	D/670006-200	789242	E.4	EC09D311B024W	267086	A.32
CSCN25A3121	101603	D.35	D/640006-200	789239	E.4	D/670006-212	789189	E.4	EC09D311B036W	267087	A.32
CSCN25A3123	101604	D.35	D/640006-212	789186	E.4	D/670006-213	789194	E.4	EC09D311B048L	267097	A.32
CSCN25A3126	247210	D.35	D/640006-213	789191	E.4	D/670006-312	789203	E.5	EC09D311B048W	267088	A.32
CSCN25A3127	101606	D.35	D/640006-242	789182	E.4	D/670006-313	789208	E.5	EC09D311B060W	267089	A.32
CSCN25A312D	110965	D.35	D/640006-243	789184	E.4	D/670006-712	789283	E.7	EC09D311B072W	267090	A.32
CSCN25A312J	207580	D.35	D/640006-312	789200	E.5	D/670006-713	789288	E.7	EC09D311B110L	267098	A.32
CSCN25A312N	110967	D.35	D/640006-313	789205	E.5	D/670006-812	789217	E.5	EC09D311B110W	267091	A.32
CSCN25A312R	110968	D.35	D/640006-342	789196	E.5	D/670006-813	789222	E.5	EC09D311B125W	267092	A.32
CSCN25A312U	247230	D.35	D/640006-343	789198	E.5	D/670006-900	789237	E.5	EC09D311B230L	267099	A.20
CSCN25A3211	101607	D.35	D/640006-712	789280	E.7	D/670006-942	789227	E.5	EC09D311B230W	267093	A.20
CSCN25A3213	101608	D.35	D/640006-812	789214	E.5	D/670006-943	789232	E.5	EC09D311B250W	267094	A.20
CSCN25A3216	207581	D.35	D/640006-813	789219	E.5	D/670007-712	789293	E.7	EC09D311B440W	267095	A.20
CSCN25A3217	101610	D.35	D/640006-842	789210	E.5	D/670007-713	789298	E.7	EC09E311B100-250	216379	A.20
CSCN25A321D	110960	D.35	D/640006-843	789212	E.5	D/670138-712	789323	E.7	EC09E311B24-60	216377	A.20
CSCN25A321J	207582	D.35	D/640006-900	789234	E.5	D/670138-713	789328	E.7	EC09E311B48-130	216378	A.20
CSCN25A321N	110962	D.35	D/640006-942	789224	E.5	D/670206-712	789303	E.7	EC12A311B012	267015	A.20
CSCN25A321R	110963	D.35	D/640006-943	789229	E.5	D/670206-713	789308	E.7	EC12A311B024	267016	A.20
CSCN30A301N	247152	D.35	D/640007-712	789290	E.7	D/670207-712	789313	E.7	EC12A311B042	267017	A.20
CSCN30A301U	247213	D.35	D/640007-713	789295	E.7	D/670207-713	789318	E.7	EC12A311B048	267018	A.20
CSCN30A3101G	247279	D.35	D/640138-712	789320	E.7	D/670238-712	789333	E.7	EC12A311B110	267019	A.20
CSCN30A3103G	247298	D.35	D/640138-713	789325	E.7	D/670238-713	789338	E.7	EC12A311B208	267021	A.20
CSCN30A3106	207583	D.35	D/640206-712	789300	E.7	D/680000-006	789271	E.6	EC12A311B230	267022	A.20
CSCN30A310J	207584	D.35	D/640207-712	789310	E.7	D/680000-007	789274	E.6	EC12A311B240	267023	A.20
CSCN30A310MU	106995	D.35	D/640207-713	789315	E.7	D/680000-201	789248	E.6	EC12A311B400	267024	A.20
CSCN30A310N	247247	D.35	D/640238-712	789330	E.7	D/680000-202	789254	E.6	EC12A311B440	267025	A.20
CSCN30A310NG	247289	D.35	D/640238-713	789335	E.7	D/680000-203	789260	E.6	EC12A311B480	267026	A.20
CSCN30A310U	247220	D.35	D/650000-006	789270	E.6	D/680000-204	789266	E.6	EC12A311B500	267027	A.20
CSCN30A310W	247270	D.35	D/650000-201	789244	E.6	D/680000-205	789268	E.6	EC12A311B600	267028	A.20
CSCN30A3123	247153	D.35	D/650000-202	789250	E.6	D/680000-220	789275	E.6	EC12A400B012	267175	A.20
CSCN30A3126G	247280	D.35	D/650000-203	789256	E.6	D/680000-230	789276	E.6	EC12A400B024	267176	A.20
CSCN30A3127	247194	D.35	D/650000-204	789262	E.6	D/680000-240	789277	E.6	EC12A400B042	267177	A.20
CSCN30A312N	247245	D.35	D/650000-301	789245	E.6	D/680000-250	789278	E.6	EC12A400B048	267178	A.20
CSCN30A312U	247263	D.35	D/650000-302	789251	E.6	D/680000-290	789279	E.6	EC12A400B110	267179	A.20
CSCN30A3216	207585	D.35	D/650000-303	789257	E.6	D/680000-301	789249	E.6	EC12A400B120	267180	A.20
CSCN30A321N	247246	D.35	D/650000-304	789263	E.6	D/680000-302	789255	E.6	EC12A400B208	267181	A.20
CSCN30D301WD	247363	D.35	D/650006-112	789179	E.4	D/680000-303	789261	E.6	EC12A400B230	267182	A.20
CSCN45A301N	247243	D.35	D/650006-142	789175	E.4	D/680000-304	789267	E.6	EC12A400B240	267183	A.20
CSCN45A3101G	247753	D.35	D/650006-143	789177	E.4	D/680006-200	789243	E.4	EC12A400B400	267184	A.20
CSCN45A3103	247846	D.35	D/650006-200	789240	E.4	D/680006-212	789190	E.4	EC12A400B440	267185	A.20
CSCN45A3106G	247299	D.35	D/650006-212	789187	E.4	D/680006-213	789195	E.4	EC12A400B480	267186	A.20
CSCN45A310J	207586	D.35	D/650006-213	789192	E.4	D/680006-312	789204	E.5	EC12A400B500	267187	A.20
CSCN45A310N	247244	D.35	D/650006-243	789185	E.4	D/680006-313	789209	E.5	EC12A400B600	267188	A.20
CSCN45A310NG	247290	D.35	D/650006-312	789201	E.5	D/680006-712	789284	E.7	EC12A800B012	267291	A.20
CSCN45A310U	207587	D.35	D/650006-313	789206	E.5	D/680006-713	789289	E.7	EC12A800B024	267292	A.20
CSCN45A3111	247963	D.35	D/650006-342	789197	E.5	D/680006-812	789218	E.5	EC12A800B042	267293	A.20
CSCN45A3116	207588	D.35	D/650006-343	789199	E.5	D/680006-813	789223	E.5	EC12A800B048	267294	A.20
CSCN45A311J	207589	D.35	D/650006-712	789281	E.7	D/680006-900	789238	E.5	EC12A800B110	267295	A.20
CSCN45A311N	247241	D.35	D/650006-713	789286	E.7	D/680006-942	789228	E.5	EC12A800B120	267296	A.20
CSCN45A311W	247273	D.35	D/650006-812	789215	E.5	D/680006-943	789233	E.5	EC12A800B208	267297	A.20
CSCN45A3127	247196	D.35	D/650006-813	789220	E.5	D/680007-712	789294	E.7	EC12A800B230	267298	A.20
CSCN45A312N	247154	D.35	D/650006-842	789211	E.5	D/680007-713	789299	E.7	EC12A800B240	267299	A.20
CSCN45A312U	247227	D.35	D/650006-843	789213	E.5	D/680138-713	789329	E.7	EC12A800B400	267300	A.20
CSCN45A3203	247155	D.35	D/650006-900	789235	E.5	D/680206-712	789304	E.7	EC12A800B440	267301	A.20
CSCN45A320N	247242	D.35	D/650006-942	789225	E.5	D/680206-713	789309	E.7	EC12A800B480	267302	A.22
CSCN55A301N	247238	D.35	D/650006-943	789230	E.5	D/680207-712	789314	E.7	EC12A800B500	267303	A.22
CSCN55A3103	247205	D.35	D/650007-712	789291	E.7	D/680207-713	789319	E.7	EC12A800B600	267304	A.22
CSCN55A3103G	248147	D.35	D/650007-713	789296	E.7	D/680238-712	789334	E.7	EC12D311B012W	267100	A.22
CSCN55A310J	207590	D.35	D/650138-712	789321	E.7	D/680238-713	789339	E.7	EC12D311B024L	267111	A.22
CSCN55A310N	247239	D.35	D/650138-713	789326	E.7	EA07A301I024	248005	A.32	EC12D311B024W	267101	A.22
CSCN55A310NG	247291	D.35	D/650206-712	789301	E.7	EA07A301I230	248003	A.32	EC12D311B036W	267102	A.22
CSCN55A310U	247225	D.35	D/650206-713	789306	E.7	EA07A301S024	247991	A.32	EC12D311B048L	267112	A.22
CSCN55A310W	247209	D.35	D/650207-712	789311	E.7	EA07A301S048	247993	A.32	EC12D311B048W	267103	A.22
CSCN55A3113	248121	D.35	D/650207-713	789316	E.7	EA07A301S110	247995	A.32	EC12D311B060W	267104	A.22
CSCN55A3116	207591	D.35	D/650238-712	789331	E.7	EA07A301S230	247997	A.32	EC12D311B072W	267105	A.22
CSCN55A3117	247198	D.35	D/660006-200	789241	E.4	EA07A310I024	248004	A.32	EC12D311B110L	267	

Controls Alphabetical Index

Cat. no.	Ref. no	Cat. pg	Cat. no.	Ref. no	Cat. pg	Cat. no.	Ref. no	Cat. pg	Cat. no.	Ref. no	Cat. pg
EC12D4008036W	267233	A.24	EC18D4008024W	267247	A.24	EC25D4008024L	267272	A.24	EC32D4008048L	267288	A.24
EC12D4008048L	267243	A.24	EC18D4008036W	267248	A.24	EC25D4008024W	267262	A.24	EC32D4008048W	267279	A.24
EC12D4008048W	267234	A.24	EC18D4008048L	267258	A.24	EC25D4008036W	267263	A.24	EC32D4008060W	267280	A.24
EC12D4008060W	267235	A.24	EC18D4008048W	267249	A.24	EC25D4008048L	267273	A.24	EC32D4008072W	267281	A.24
EC12D4008072W	267236	A.24	EC18D4008060W	267250	A.24	EC25D4008048W	267264	A.24	EC32D4008110L	267289	A.24
EC12D4008110L	267244	A.24	EC18D4008072W	267251	A.24	EC25D4008060W	267265	A.24	EC32D4008110W	267282	A.24
EC12D4008110W	267237	A.24	EC18D4008110L	267259	A.24	EC25D4008072W	267266	A.24	EC32D4008132W	267283	A.24
EC12D4008132W	267238	A.20	EC18D4008110W	267252	A.24	EC25D4008110L	267274	A.24	EC32D4008230L	267290	A.20
EC12D4008230L	267245	A.20	EC18D4008125W	267253	A.20	EC25D4008110W	267267	A.20	EC32D4008230W	267284	A.20
EC12D4008230W	267239	A.20	EC18D4008230L	267260	A.20	EC25D4008125W	267268	A.20	EC32D4008320W	267285	A.20
EC12D4008320W	267240	A.20	EC18D4008230W	267254	A.20	EC25D4008230L	267275	A.20	EC32D4008440W	267286	A.20
EC12D4008440W	267241	A.20	EC18D4008250W	267255	A.20	EC25D4008230W	267269	A.20	EC32D8008012W	267392	A.20
EC12D8008012W	267347	A.20	EC18D4008440W	267256	A.20	EC25D4008250W	267270	A.20	EC32D8008024W	267393	A.20
EC12D8008024L	267358	A.20	EC18D8008012W	267362	A.20	EC25D4008440W	267271	A.20	EC32D8008036W	267394	A.20
EC12D8008024W	267348	A.20	EC18D8008024L	267373	A.20	EC25D8008012W	267377	A.20	EC32D8008048W	267395	A.20
EC12D8008036W	267349	A.20	EC18D8008024W	267363	A.20	EC25D8008024W	267378	A.20	EC32D8008060W	267396	A.20
EC12D8008048L	267359	A.20	EC18D8008036W	267364	A.20	EC25D8008036W	267379	A.20	EC32D8008072W	267397	A.20
EC12D8008048W	267350	A.20	EC18D8008048L	267374	A.20	EC25D8008048W	267380	A.20	EC32D8008110W	267398	A.20
EC12D8008060W	267351	A.20	EC18D8008048W	267365	A.20	EC25D8008060W	267381	A.20	EC32D8008132W	267399	A.20
EC12D8008072W	267352	A.20	EC18D8008060W	267366	A.20	EC25D8008072W	267382	A.20	EC32D8008320W	267400	A.20
EC12D8008110L	267360	A.20	EC18D8008072W	267367	A.20	EC25D8008110W	267383	A.20	EC32D8008320W	267401	A.20
EC12D8008110W	267353	A.20	EC18D8008110L	267375	A.20	EC25D8008125W	267384	A.20	EC32D8008440W	267402	A.22
EC12D8008132W	267354	A.22	EC18D8008110W	267368	A.20	EC25D8008230W	267385	A.20	EC32E3008100-250	216391	A.22
EC12D8008230L	267361	A.22	EC18D8008132W	267369	A.22	EC25D8008250W	267386	A.20	EC32E300824-60	216389	A.22
EC12D8008230W	267356	A.22	EC18D8008230L	267376	A.22	EC25D8008440W	267387	A.22	EC32E300848-130	216390	A.22
EC12D8008320W	267356	A.22	EC18D8008230W	267370	A.22	EC25E3118100-250	216388	A.22	EC32E4008100-250	216406	A.22
EC12D8008440W	267357	A.22	EC18D8008320W	267371	A.22	EC25E311824-60	216386	A.22	EC32E400824-60	216404	A.22
EC12E3118100-250	216382	A.22	EC18D8008440W	267372	A.22	EC25E311848-130	216387	A.22	EC32E400848-130	216405	A.22
EC12E311824-60	216380	A.22	EC18E3118100-250	216385	A.22	EC25E4008100-250	216403	A.22	EC32E8008100-250	216418	A.22
EC12E311848-130	216381	A.22	EC18E311824-60	216383	A.22	EC25E400824-60	216401	A.22	EC32E8008100-250	216416	A.22
EC12E4008100-250	216397	A.22	EC18E311848-130	216384	A.22	EC25E400848-130	216402	A.22	EC32E800848-130	216417	A.22
EC12E400824-60	216395	A.22	EC18E4008100-250	216400	A.22	EC25E8008100-250	216415	A.22	EC3PP1B	268943	A.22
EC12E400848-130	216396	A.22	EC18E400824-60	216398	A.22	EC25E800824-60	216413	A.22	EC3PP2B	268946	A.22
EC12E8008100-250	216409	A.22	EC18E400848-130	216399	A.22	EC25E800848-130	216414	A.22	EC40A3008012	267071	A.22
EC12E800824-60	216407	A.22	EC18E8008100-250	216412	A.22	EC32A3008012	267057	A.22	EC40A3008024	267072	A.22
EC12E800848-130	216408	A.22	EC18E800824-60	216410	A.22	EC32A3008024	267058	A.22	EC40A3008042	267073	A.24
EC18A3118012	267029	A.22	EC18E800848-130	216411	A.22	EC32A3008042	267059	A.22	EC40A3008048	267074	A.24
EC18A3118024	267030	A.22	EC25A3118012	267043	A.22	EC32A3008048	267060	A.22	EC40A3008110	267075	A.24
EC18A3118042	267031	A.24	EC25A3118024	267044	A.24	EC32A3008110	267061	A.22	EC40A3008120	267076	A.24
EC18A3118048	267032	A.24	EC25A3118042	267045	A.24	EC32A3008120	267062	A.24	EC40A3008208	267077	A.24
EC18A3118110	267033	A.24	EC25A3118048	267046	A.24	EC32A3008208	267063	A.24	EC40A3008230	267078	A.24
EC18A3118120	267034	A.24	EC25A3118110	267047	A.24	EC32A3008230	267064	A.24	EC40A3008240	267079	A.24
EC18A3118208	267035	A.24	EC25A3118120	267048	A.24	EC32A3008240	267065	A.24	EC40A3008400	267080	A.24
EC18A3118230	267036	A.24	EC25A3118208	267049	A.24	EC32A3008400	267066	A.24	EC40A3008440	267081	A.24
EC18A3118240	267037	A.24	EC25A3118230	267050	A.24	EC32A3008440	267067	A.24	EC40A3008480	267082	A.24
EC18A3118400	267038	A.24	EC25A3118240	267051	A.24	EC32A3008480	267068	A.24	EC40A3008500	267083	A.24
EC18A3118440	267039	A.24	EC25A3118400	267052	A.24	EC32A3008500	267069	A.24	EC40A3008600	267084	A.24
EC18A3118480	267040	A.24	EC25A3118440	267053	A.24	EC32A3008600	267070	A.24	EC40D3008012W	267160	A.20
EC18A3118500	267041	A.24	EC25A3118480	267054	A.24	EC32A4008012	267217	A.20	EC40D3008024L	267171	A.20
EC18A3118600	267042	A.24	EC25A3118500	267055	A.24	EC32A4008024	267218	A.24	EC40D3008024W	267161	A.20
EC18A4008012	267189	A.24	EC25A3118600	267056	A.24	EC32A4008042	267219	A.20	EC40D3008036W	267162	A.22
EC18A4008024	267190	A.24	EC25A4008012	267203	A.24	EC32A4008048	267220	A.20	EC40D3008048L	267172	A.22
EC18A4008042	267191	A.20	EC25A4008024	267204	A.24	EC32A4008110	267221	A.20	EC40D3008048W	267163	A.22
EC18A4008048	267192	A.20	EC25A4008042	267205	A.20	EC32A4008120	267222	A.22	EC40D3008060W	267164	A.24
EC18A4008110	267193	A.20	EC25A4008048	267206	A.20	EC32A4008208	267223	A.22	EC40D3008072W	267165	A.24
EC18A4008120	267194	A.22	EC25A4008110	267207	A.20	EC32A4008230	267224	A.22	EC40D3008110L	267173	A.24
EC18A4008208	267195	A.22	EC25A4008120	267208	A.22	EC32A4008240	267225	A.24	EC40D3008110W	267166	A.29
EC18A4008230	267196	A.22	EC25A4008208	267209	A.22	EC32A4008400	267226	A.24	EC40D3008125W	267167	A.29
EC18A4008240	267197	A.24	EC25A4008230	267210	A.22	EC32A4008440	267227	A.24	EC40D3008230L	267174	A.20
EC18A4008400	267198	A.24	EC25A4008240	267211	A.24	EC32A4008480	267228	A.20	EC40D3008230W	267168	A.20
EC18A4008440	267199	A.24	EC25A4008400	267212	A.24	EC32A4008500	267229	A.20	EC40D3008250W	267169	A.20
EC18A4008480	267200	A.20	EC25A4008440	267213	A.24	EC32A4008600	267230	A.20	EC40D3008440W	267170	A.20
EC18A4008500	267201	A.20	EC25A4008480	267214	A.20	EC32A8008012	267333	A.20	EC40E3008100-250	216394	A.20
EC18A4008600	267202	A.20	EC25A4008500	267215	A.20	EC32A8008024	267334	A.20	EC40E300824-60	216392	A.20
EC18A8008012	267305	A.20	EC25A4008600	267216	A.20	EC32A8008042	267335	A.20	EC40E300848-130	216393	A.20
EC18A8008024	267306	A.20	EC25A8008012	267319	A.20	EC32A8008048	267336	A.20	EC4PP1B	268944	A.20
EC18A8008042	267307	A.20	EC25A8008024	267320	A.20	EC32A8008110	267337	A.20	EC4PP2B	268947	A.20
EC18A8008048	267308	A.20	EC25A8008042	267321	A.20	EC32A8008120	267338	A.20	ECACA4048012	268196	B.18
EC18A8008110	267309	A.20	EC25A8008048	267322	A.20	EC32A8008208	267339	A.20	ECACA4048024	268197	B.18
EC18A8008120	267310	A.20	EC25A8008110	267323	A.20	EC32A8008230	267340	A.20	ECACA4048042	268198	B.18
EC18A8008208	267311	A.20	EC25A8008120	267324	A.20	EC32A8008240	267341	A.20	ECACA4048048	268199	B.18
EC18A8008230	267312	A.20	EC25A8008208	267325	A.20	EC32A8008400	267342	A.20	ECACA4048110	268200	B.18
EC18A8008240	267313	A.20	EC25A8008230	267326	A.20	EC32A8008440	267343	A.20	ECACA4048120	268201	B.18
EC18A8008400	267314	A.20	EC25A8008240	267327	A.20	EC32A8008480	267344	A.22	ECACA4048208	268202	B.18
EC18A8008440	267315	A.20	EC25A8008400	267328	A.20	EC32A8008500	267345	A.22	ECACA4048230	268203	B.18
EC18A8008480	267316	A.22	EC25A8008440	267329	A.20	EC32A8008600	267346	A.22	ECACA4048240	268204	B.18
EC18A8008500	267317	A.22	EC25A8008480	267330	A.20	EC32D3008012W	267145	A.22	ECACA4048400	268205	B.18
EC18A8008600	267318	A.22	EC25A8008500	267331	A.22	EC32D3008024L	267156	A.22	ECACA4048440	268206	B.18
EC18D3118012W	267115	A.22	EC25A8008600	267332	A.22	EC32D3008024W	267146	A.22	ECACA4048480	268207	B.18
EC18D3118024L	267126	A.22	EC25D3118012W	267130	A.22	EC32D3008036W	267147	A.22	ECACA4048500	268208	B.18
EC18D3118024W	267116	A.22	EC25D3118024L	267141	A.22	EC32D3008048L	267157	A.22	ECACA4048600	268209	B.18
EC18D3118036W	267117	A.22	EC25D3118024W	267131	A.22	EC32D3008048W	267148	A.22	ECACA418012	268182	B.18
EC18D3118048L	267127	A.22	EC25D3118036W	267132	A.22	EC32D3008060W	2671				

Controls Alphabetical Index

Alphabetical index

Intro

A

B

C

D

E

F

G

H

I

X

Cat. no.	Ref. no	Cat. pg	Cat. no.	Ref. no	Cat. pg	Cat. no.	Ref. no	Cat. pg	Cat. no.	Ref. no	Cat. pg
ECACA422B012	268168	B.18	ECACD431B230W	268233	B.18	ECML1DS048	269326	A.27	EF50A300B012	270000	A.21
ECACA422B024	268169	B.18	ECACD431B250W	268234	B.18	ECML1DS072	269327	A.27	EF50A300B024	270001	A.21
ECACA422B042	268170	B.18	ECACD431B400W	268235	B.18	ECML1DS125	269328	A.27	EF50A300B048	270003	A.21
ECACA422B048	268171	B.18	ECACD440B012W	268210	B.18	ECML1DS250	269329	A.27	EF50A300B110	270004	A.21
ECACA422B110	268172	B.18	ECACD440B024L	268221	B.18	ECML1DS440	269330	A.27	EF50A300B208	270007	A.21
ECACA422B120	268173	B.18	ECACD440B024W	268211	B.18	ECML2AS032	268925	A.27	EF50A300B230	270008	A.21
ECACA422B208	268174	B.18	ECACD440B036W	268212	B.18	ECML2AS060	268926	A.29	EF50A300B400	270009	A.21
ECACA422B230	268175	B.18	ECACD440B048L	268222	B.18	ECML2AS127	268927	A.29	EF50A300B480	270011	A.21
ECACA422B240	268176	B.18	ECACD440B048W	268213	B.18	ECML2AS277	268928	A.29	EF50A300B575	270013	A.21
ECACA422B400	268177	B.18	ECACD440B060W	268214	B.18	ECML2AS480	268929	A.29	EF50A300B600	270014	A.21
ECACA422B440	268178	B.18	ECACD440B072W	268215	B.18	ECML2AS660	268930	A.27	EF50A400B012	270095	A.21
ECACA422B480	268179	B.18	ECACD440B110L	268223	B.18	ECML2DS036	269331	A.27	EF50A400B024	270096	A.25
ECACA422B500	268180	B.18	ECACD440B110W	268216	B.18	ECML2DS048	269332	A.27	EF50A400B048	270098	A.25
ECACA422B600	268181	B.18	ECACD440B125W	268217	B.18	ECML2DS072	269333	A.29	EF50A400B110	270100	A.25
ECACA431B012	268154	B.18	ECACD440B230L	268224	B.18	ECML2DS125	269334	A.29	EF50A400B208	270101	A.25
ECACA431B024	268155	B.18	ECACD440B230W	268218	B.18	ECML2DS250	269335	A.29	EF50A400B230	270102	A.25
ECACA431B042	268156	B.18	ECACD440B250W	268219	B.18	ECML2DS440	269336	A.27	EF50A400B400	270103	A.25
ECACA431B048	268157	B.18	ECACD440B400W	268220	B.18	ECML3AS032	255005	A.27	EF50A400B480	270105	A.25
ECACA431B110	268158	B.18	ECACE404B100-250	216433	B.18	ECML3AS060	255006	A.28	EF50A400B575	270107	A.25
ECACA431B120	268159	B.18	ECACE404B24-60	216431	B.18	ECML3AS127	255007	A.28	EF50A400B600	270108	A.25
ECACA431B208	268160	B.18	ECACE404B48-130	216432	B.18	ECML3AS227	255008	A.28	EF50E300B100-250	270076	A.25
ECACA431B230	268161	B.18	ECACE413B100-250	216430	B.18	ECML3AS480	255009	A.28	EF50E300B24-60	270074	A.25
ECACA431B240	268162	B.18	ECACE413B24-60	216428	B.18	ECML3AS660	255010	A.28	EF50E300B250-500	270078	A.25
ECACA431B400	268163	B.18	ECACE413B48-130	216429	B.18	ECML3DS036	255011	A.28	EF50E300B48-130	270075	A.25
ECACA431B440	268164	B.18	ECACE422B100-250	216427	B.18	ECML3DS048	255012	A.28	EF50E400B100-250	270139	A.25
ECACA431B480	268165	B.18	ECACE422B24-60	216425	B.18	ECML3DS072	255013	A.28	EF50E400B24-60	270137	A.21
ECACA431B500	268166	B.18	ECACE422B48-130	216426	B.18	ECML3DS125	255014	A.28	EF50E400B250-500	270140	A.21
ECACA431B600	268167	B.18	ECACE431B100-250	216424	B.18	ECML3DS250	255015	A.28	EF50E400B48-130	270138	A.21
ECACA440B012	268140	B.18	ECACE431B24-60	216422	B.18	ECML3DS440	255017	A.28	EF65A300B012	270015	A.21
ECACA440B024	268141	B.18	ECACE431B48-130	216423	B.18	ECPT30SC	268913	A.28	EF65A300B024	270016	A.21
ECACA440B042	268142	B.18	ECACE440B100-250	216421	B.18	ECPT30SD	268916	A.28	EF65A300B048	270018	A.21
ECACA440B048	268143	B.18	ECACE440B24-60	216419	B.18	ECPT60SC	268914	A.28	EF65A300B110	270019	A.21
ECACA440B110	268144	B.18	ECACE440B48-130	216420	B.18	ECPT60SD	268917	A.28	EF65A300B208	270021	A.21
ECACA440B120	268145	B.18	ECBB1B2	268942	A.20	ECRT1B10B	268996	A.28	EF65A300B230	270022	A.21
ECACA440B208	268146	B.18	ECBB2B2	268945	A.20	ECRT1B10C	268997	A.28	EF65A300B400	270023	A.21
ECACA440B230	268147	B.18	ECBP45	268962	A.20	ECRT1B10D	268998	A.28	EF65A300B480	270025	A.23
ECACA440B240	268148	B.18	ECBP55	268953	A.20	ECRT1B10F	268999	A.28	EF65A300B575	270027	A.23
ECACA440B400	268149	B.18	ECCS1A012S	268687	A.20	ECRT1B10G	269000	A.28	EF65A300B600	270028	A.23
ECACA440B440	268150	B.18	ECCS1A024S	268688	A.20	ECRT1B10H	269001	A.28	EF65A300B800	270029	A.21
ECACA440B480	268151	B.18	ECCS1A042S	268689	A.20	ECRT1B10I	269002	A.28	EF65A300B824-60	270030	A.21
ECACA440B500	268152	B.18	ECCS1A048S	268690	A.20	ECRT1B10J	269003	A.28	EF65A300B848-130	270032	A.21
ECACA440B600	268153	B.18	ECCS1A110S	268691	A.20	ECRT1B10L	269004	A.28	EF65A300B8110	270033	A.21
ECACD404B012W	268270	B.18	ECCS1A120S	268692	A.20	ECRT1B10M	269005	A.28	EF65A300B8208	270035	A.21
ECACD404B024W	268271	B.18	ECCS1A208S	268693	A.20	ECRT1B10N	269006	A.28	EF65A300B230	270036	A.21
ECACD404B036W	268272	B.18	ECCS1A230S	268694	A.20	ECRT1B10P	269007	A.28	EF65A300B400	270037	A.21
ECACD404B048W	268273	B.18	ECCS1A240S	268695	A.20	ECRT1B10S	269008	A.28	EF65A300B480	270039	A.25
ECACD404B060W	268274	B.18	ECCS1A400S	268696	A.20	ECRT1B10T	269009	A.28	EF65A300B575	270041	A.25
ECACD404B072W	268275	B.18	ECCS1A440S	268697	A.20	ECRT1B1S	268963	A.28	EF65A300B600	270042	A.25
ECACD404B110W	268276	B.18	ECCS1A480S	268698	A.20	ECRT2B10N	268103	A.28	EF65E300B100-250	270081	A.21
ECACD404B125W	268277	B.18	ECCS1A500S	268699	A.20	ECRT2B10P	268104	A.28	EF65E300B24-60	270079	A.23
ECACD404B230W	268278	B.18	ECCS1A575S	268984	A.20	ECRT2B10S	268105	A.28	EF65E300B250-500	270082	A.23
ECACD404B250W	268279	B.18	ECCS1A600S	268700	A.20	ECRT2B10T	268106	A.28	EF65E300B48-130	270080	A.23
ECACD404B400W	268280	B.18	ECCS2A012S	268716	A.20	ECRT2B10U	268107	A.28	EF65E300B800-250	270197	A.23
ECACD413B012W	268400	B.18	ECCS2A024S	268717	A.20	ECRT2B10V	268108	A.28	EF65E300B24-60	270195	A.21
ECACD413B024L	268411	B.18	ECCS2A042S	268718	A.20	ECRT2B10W	268109	A.27	EF65E300B250-500	270198	A.21
ECACD413B024W	268401	B.18	ECCS2A048S	268719	A.20	ECRT2B1S	268964	A.27	EF65E300B48-130	270196	A.21
ECACD413B036W	268402	B.18	ECCS2A110S	268720	A.29	ECSUDI440	268931	A.27	EF80A300B012	270029	A.21
ECACD413B048L	268412	B.18	ECCS2A120S	268721	A.29	ECSURC048	268932	A.27	EF80A300B024	270030	A.21
ECACD413B048W	268403	B.18	ECCS2A208S	268722	A.29	ECSURC127	268933	A.55	EF80A300B048	270032	A.21
ECACD413B060W	268404	B.18	ECCS2A230S	268723	A.29	ECSURC250	268934	A.55	EF80A300B110	270033	A.21
ECACD413B072W	268405	B.18	ECCS2A240S	268724	A.29	ECSURC440	268935	A.55	EF80A300B208	270035	A.21
ECACD413B110L	268413	B.18	ECCS2A400S	268725	A.29	ECSURC600	268936	A.55	EF80A300B230	270036	A.21
ECACD413B110W	268406	B.18	ECCS2A440S	268726	A.26	ECSUVA048	268937	A.55	EF80A300B400	270037	A.21
ECACD413B125W	268407	B.18	ECCS2A480S	268727	A.26	ECSUVA127	268938	A.55	EF80A300B480	270039	A.25
ECACD413B230L	268414	B.18	ECCS2A500S	268728	A.26	ECSUVA250	268939	A.55	EF80A300B575	270041	A.25
ECACD413B230W	268408	B.18	ECCS2A575S	268985	A.26	ECSUVA440	268940	A.55	EF80A300B600	270042	A.25
ECACD413B250W	268409	B.18	ECCS2A600S	268729	A.26	ECSUVA600	268941	A.55	EF80A400B012	270109	A.25
ECACD413B400W	268410	B.18	ECFA202S	268874	A.26	EF10SA300B012	270058	A.55	EF80A400B024	270110	A.25
ECACD422B012W	268240	B.18	ECFA211S	268872	A.26	EF10SA300B024	270059	A.55	EF80A400B048	270112	A.25
ECACD422B024L	268251	B.18	ECFA220S	268873	A.26	EF10SA300B048	270061	A.55	EF80A400B110	270114	A.25
ECACD422B024W	268241	B.18	ECFA404S	268885	A.26	EF10SA300B110	270062	A.55	EF80A400B208	270115	A.25
ECACD422B036W	268242	B.18	ECFA413S	268884	A.26	EF10SA300B208	270064	A.55	EF80A400B230	270116	A.25
ECACD422B048L	268252	B.18	ECFA422S	268883	A.26	EF10SA300B230	270065	A.57	EF80A400B400	270117	A.25
ECACD422B048W	268243	B.18	ECFA422SE	268886	A.26	EF10SA300B400	270066	A.55	EF80A400B480	270119	A.21
ECACD422B060W	268244	B.18	ECFA431S	268882	A.26	EF10SA300B480	270070	A.55	EF80A400B575	270121	A.21
ECACD422B072W	268245	B.18	ECFA440S	268881	A.26	EF10SA300B575	270072	A.55	EF80A400B600	270122	A.21
ECACD422B110L	268253	B.18	ECKS1RV	268948	A.26	EF10SA300B600	270073	A.55	EF80A400B012	270177	A.21
ECACD422B110W	268246	B.18	ECKS1YD	268951	A.26	EF10SE300B100-250	270093	A.55	EF80A400B024	270178	A.25
ECACD422B125W	268247	B.18	ECKS2RV	268950	A.26	EF10SE300B24-60	270091	A.55	EF80A400B048	270180	A.25
ECACD422B230L	268254	B.18	ECKS2YD	268952	A.26	EF10SE300B250-500	270094	A.55	EF80A400B110	270182	A.25
ECACD422B230W	268248	B.18	ECLA202S	268901	A.26	EF10SE300B48-130	270092	A.57	EF80A400B208	270183	A.25
ECACD422B250W	268249	B.18	ECLA211S	268900	A.26	EF40A800B012	270149	A.27	EF80A400B230	270184	A.21
ECACD422B400W	268250	B.18	ECLA220S	268899	A.26	EF40A800B024	270150	A.27	EF80A400B400	270185	A.21
ECACD431B012W	268225	B.18	ECM1AL25	268954	A.26	EF40A800B048	270152	A.27	EF80A400B480	270187	A.21
ECACD431B024L	268236	B.18	ECM1AL32	268955	A.26	EF					

Controls Alphabetical Index

Cat. no.	Ref. no	Cat. pg	Cat. no.	Ref. no	Cat. pg	Cat. no.	Ref. no	Cat. pg	Cat. no.	Ref. no	Cat. pg
EF80E00824-60	270200	A.23	GPAAURAAAD	101330	C.8	GPS1BSAE	101215	C.3	LB1DJ	112318	A.43/B.15
EF80E008250-500	270203	A.23	GPAAURAAF	101333	C.8	GPS1BSAF	101216	C.3	LB1DJMP	108999	A.43/B.15
EF80E00848-130	270201	A.23	GPAAURAAJ	101332	C.8	GPS1BSAG	101217	C.3	LB1DK	112654	A.43/B.15
EF95A3008012	270043	A.23	GPAAURAAK	101334	C.8	GPS1BSAH	101218	C.3	LB1DN	112319	A.43/B.15
EF95A3008024	270044	A.23	GPAAURAAAM	101335	C.8	GPS1BSAJ	101219	C.3	LB1DP	112655	A.43/B.15
EF95A3008048	270046	A.23	GPAAURAAAN	101336	C.8	GPS1BSAK	101220	C.3	LB1DR	112656	A.43/B.15
EF95A3008110	270047	A.25	GPAAURAAAR	101337	C.8	GPS1BSAL	101221	C.3	LB1DT	112657	A.43/B.15
EF95A3008208	270049	A.25	GPAAURAAAU	101338	C.8	GPS1BSAM	101222	C.3	LB1DWD	113524	A.43/B.15
EF95A3008230	270050	A.25	GPAAURAAAW	101339	C.8	GPS1BSAN	101223	C.3	LB1DWE	113525	A.43/B.15
EF95A3008400	270052	A.25	GPAAURAAV	101340	C.8	GPS1BSAP	101224	C.3	LB1DWG	113526	A.43/B.15
EF95A3008480	270054	A.25	GPB1802A	101390	C.9	GPS1BSAR	101225	C.3	LB1DWI	113527	A.43/B.15
EF95A3008575	270056	A.25	GPB1803A	101391	C.9	GPS1BHAA	101280	C.5	LB1DWJ	113528	A.43/B.15
EF95A3008600	270057	A.25	GPB1804A	101392	C.9 / C.29	GPS1BHAB	101281	C.5	LB1DWN	113529	A.43/B.15
EF95A4008012	270123	A.25	GPB1805A	101393	C.9 / C.29	GPS1BHAC	101282	C.5	LB3A1	110449	A.43
EF95A4008024	270124	A.25	GPB1812A	101394	C.9	GPS1BHAD	101283	C.5	LB3A12G	116815	A.43
EF95A4008048	270126	A.25	GPB1813A	101395	C.9	GPS1BHAE	101284	C.5	LB3A13	107491	A.43
EF95A4008110	270128	A.21	GPB1814A	101396	C.9	GPS1BHAF	101285	C.5	LB3A13G	116818	A.43
EF95A4008208	270129	A.21	GPB1815A	101397	C.9	GPS1BHAG	101286	C.5	LB3A15	110386	A.43
EF95A4008230	270130	A.21	GPB1822A	101398	C.9	GPS1BHAJ	101287	C.5	LB3A1G	116593	A.43
EF95A4008400	270131	A.21	GPB1824A	101399	C.9	GPS1BHAK	101288	C.5	LB3A1MP	108125	A.43
EF95A4008480	270133	A.23	GPB1FA	107186	C.9	GPS1MHAA	101289	C.5	LB3A2	110450	A.43
EF95A4008575	270135	A.23	GPB1GA	101408	C.9 / C.29	GPS1MHAC	101290	C.5	LB3A2G	116810	A.43
EF95A4008600	270136	A.23	GPB2802A	101400	C.9	GPS1MHAD	101291	C.5	LB3A3	110451	A.43
EF95E3008100-250	270089	A.23	GPB2803A	101401	C.9	GPS1MHAE	101292	C.5	LB3A32G	116814	A.43
EF95E300824-60	270087	A.25	GPB2804A	101402	C.9	GPS1MHAF	101293	C.5	LB3A3G	116594	A.43
EF95E3008250-500	270090	A.25	GPB2812A	101403	C.9	GPS1MHAG	101294	C.5	LB3A3MP	108128	A.43
EF95E300848-130	270088	A.25	GPB2813A	101404	C.9	GPS2BHAK	101249	C.3	LB3AA	110452	A.43
EF95E4008100-250	270147	A.25	GPB2814A	101405	C.9	GPS2BHAL	101250	C.3	LB3AAMP	108842	A.43
EF95E400824-60	270145	A.21	GPB2822A	101406	C.9	GPS2BHAM	101250	C.3	LB3A5	110453	A.43
EF95E4008250-500	270148	A.21	GPB2824A	101407	C.9	GPS2BHAN	101251	C.3	LB3A5G	292948	A.43
EF95E400848-130	270146	A.21	GPB2FA	107187	C.9	GPS2BHAP	101252	C.3	LB3A5MP	108129	A.43
EFM2AL80	255035	A.21	GPB2GA	101409	C.9	GPS2BHAS	101253	C.3	LB3A6	110454	A.43
EFM2EL80	255000	A.21	GPECA	101371	C.11	GPS2BHAT	101254	C.3	LB3A6G	116592	A.43
EPL	104798	A.46	GPEF41A	101367	C.11	GPS2BHAU	101255	C.3	LB3A7	110455	A.43
GPAL1HAB	101363	C.9	GPEF55A	101368	C.11	GPS2BHAA	101256	C.3	LB3A7G	116812	A.43
GPAL1HAR	101364	C.9	GPELCAJ	101385	C.11	GPS2MHAK	101295	C.5	LB3A7MP	108131	A.43
GPAP2HAB	101502	C.9	GPELCAK	101386	C.11	GPS2MHAL	101296	C.5	LB3A8	110456	A.43
GPAP2HAR	101503	C.9	GPELCAO	101387	C.11	GPS2MHAM	101297	C.5	LB3A8G	116811	A.43
GPAC01F8A	101304	C.7	GPELCAV	101388	C.11	GPS2MHAN	101297	C.5	LB3A9	133192	A.43
GPAC02LLA	101307	C.7	GPELCAW	101389	C.11	GPS2MHAP	101298	C.5	LB3A9G	116817	A.43
GPAC02LRA	101310	C.7	GPELGAJ	101375	C.11	GPS2MHAR	101299	C.5	LB3AC	110433	A.43
GPAC10F8A	101303	C.7	GPELGAN	101376	C.11	GPS2MHAS	101300	C.5	LB3AD	104641	A.43
GPAC11LLA	101305	C.7	GPELGAU	101377	C.11	GPS2MHAU	101301	C.5	LB3ADG	116597	A.43
GPAC11LRA	101308	C.7	GPELGAX	101378	C.11	GPVDA	101514	C.8	LB3AE	110434	A.43
GPAC20LLA	101306	C.7	GPELGAY	101379	C.11	GPVPA	101515	C.8	LB3AEMP	104638	A.43
GPAC20LRA	101309	C.7	GPELRAJ	101380	C.11	KKITAE100-250	246132	A.21	LB3AF	110435	A.43
GPAD010LLA	101316	C.7	GPELRAN	101381	C.11	KKITAE24-60	246130	A.21	LB3AFG	116596	A.43
GPAD010LLA	101315	C.7	GPELRAU	101382	C.11	KKIT4E24-60	246130	A.21	LB3AH	110436	A.43
GPAD100LLA	101314	C.7	GPELRAX	101383	C.11	KKIT4E250-500	246133	A.21	LB3AHG	116804	A.43
GPAD1010LLA	101313	C.7	GPELRAV	101384	C.11	KKIT4E48-130	246131	A.21	LB3AJ	104643	A.43
GPAE11LLA	101317	C.7	GPEPNA	101369	C.11	KKIT5E100-250	246136	A.21	LB3AJG	116598	A.43
GPAKS1A	101509	C.8	GPEPA	101370	C.11	KKIT5E24-60	246134	A.23	LB3AK	110438	A.43
GPAL01FRA	101312	C.7	GPEPKA	101374	C.11	KKIT5E250-500	246137	A.23	LB3AL	110439	A.43
GPAL10FRA	101311	C.7	GPEPLA	101373	C.11	KKIT5E48-130	246135	A.23	LB3AM	110440	A.43
GPAPT1E	107315	C.9	GPEPMA	101372	C.11	KKIT7E100-250	246140	A.23	LB3AMG	116808	A.43
GPAPT2A	107182	C.8	GPE541A	101365	C.11	KKIT7E24-60	246138	A.23	LB3AN	104644	A.43
GPASLRAA1	101318	C.8	GPE555A	101366	C.11	KKIT7E250-500	246141	A.23	LB3ANG	116591	A.43
GPASLRAA11	101194	C.8	GPEUTA	107097	C.11	KKIT7E48-130	246139	A.23	LB3ANMP	108137	A.43
GPASLRAAF	101319	C.8	GPF1B1A	101418	A.47	KKIT8E100-250	246144	A.23	LB3AR	110442	A.43
GPASLRAAG	101320	C.8	GPF1B4A	107163	A.47	KKIT8E24-60	246142	A.23	LB3ARG	116595	A.43
GPASLRAAJ	101321	C.8	GPF1C8A	101427	A.47	KKIT8E250-500	246145	A.23	LB3AS	110441	A.43
GPASLRAAM	101322	C.8	GPF1L02AA	101411	A.47	KKIT8E48-130	246143	A.21	LB3ASJ	125546	A.43
GPASLRAAN	101323	C.8	GPF1L02DA	101412	A.47	LB1A1	110416	A.21	LB3AT	110443	A.43
GPASLRAAR	101324	C.8	GPF1L04AA	107165	A.47	LB1A12	113869	A.21	LB3ATG	116809	A.43
GPASLRAAU	101325	C.8	GPF1L04DA	107166	A.47	LB1A13MP	108982	A.21	LB3AU	104645	A.43
GPASLRAAW	101326	C.8	GPF1L25AA	101413	A.47	LB1A1MP	108980	A.23	LB3AUG	116805	A.43
GPASLRAAY	101327	C.8	GPF1L25CT1	101512	A.47	LB1A2	110417	A.23	LB3AUMP	108139	A.43
GPASLRADD	101328	C.8	GPF1L25DA	101414	A.47	LB1A4	110419	A.23	LB3AV	110444	A.43
GPASLRADJ	101329	C.8	GPF1L45CT1	101513	A.47	LB1AAMP	110388	A.23	LB3AVG	136763	A.43
GPAPU20LCAA11	112185	C.8	GPF282A	101419	A.47	LB1A6	110421	A.29	LB3AW	110445	A.43
GPAPU20LCAAC	101353	C.8	GPF283A	101420	A.47	LB1A6MP	108985	A.29	LB3AWG	116807	A.43
GPAPU20LCAAD	101352	C.8	GPFL04AA	107190	A.47	LB1A7	110422	A.43/B.15	LB3AX	110446	A.43
GPAPU20LCAAF	101355	C.8	GPFL04DA	107191	A.47	LB1A7MP	108986	A.43/B.15	LB3AY	110447	A.43
GPAPU20LCAAG	101354	C.8	GPFL07AA	101417	A.47	LB1A8	110423	A.43/B.15	LB3AYG	116806	A.43
GPAPU20LCAAJ	101356	C.8	GPFL245AA	101415	A.47	LB1A9	113979	A.43/B.15	LB3DB	112320	A.43
GPAPU20LCAAM	101357	C.8	GPFL245DA	101416	A.47	LB1AE	110401	A.43/B.15	LB3DBG	293027	A.43
GPAPU20LCAAN	101358	C.8	GPS1BHAA	101234	C.3	LB1AH	110403	A.43/B.15	LB3DD	112326	A.43
GPAPU20LCAAR	101359	C.8	GPS1BHAB	101235	C.3	LB1AJ	104633	A.43/B.15	LB3DDG	116612	A.43
GPAPU20LCAAU	101360	C.8	GPS1BHAC	101236	C.3	LB1AK	110405	A.43/B.15	LB3DF	112660	A.43
GPAPU20LCAAV	101361	C.8	GPS1BHAD	101237	C.3	LB1AL	110406	A.43/B.15	LB3DH	112661	A.43
GPAPU20LCAAY	101362	C.8	GPS1BHAE	101238	C.3	LB1AN	104634	A.43/B.15	LB3DHG	116615	A.43
GPAPU20LTA11	110360	C.8	GPS1BHAF	101239	C.3	LB1ANMP	108992	A.43/B.15	LB3DI	112662	A.43
GPAPU20LTAAC	101342	C.8	GPS1BHAG	101240	C.3	LB1AR	110409	A.43/B.15	LB3DJ	112328	A.43
GPAPU20LTAAD	101341	C.8	GPS1BHAA	101241	C.3	LB1AT	110410	A.43/B.15	LB3DJG	116616	A.43
GPAPU20LTAAF	101344	C.8	GPS1BHAB	101242	C.3	LB1AU	104635	A.43/B.15	LB3DK	112663	A.43
GPAPU20LTAAG	101343	C.8	GPS1BHAC	101243	C.3	LB1AUMP	108994	A.43/B.15	LB3DKG	116613	A.43
GPAPU20LTAAJ	101345	C.8	GPS1BHAD	101244	C.3	LB1AW	110412	A.43/B.15	LB3DN	112329	A.43
GPAPU20LTAAM	101346	C.8	GPS1BHAE	101245	C.3	LB1AWMP	108118	A.43/B.15	LB3DP	112664	A.43
GPAPU20LTAAN	101347	C.8	GPS1BHAF	101246	C.3	LB1AY	110414	A.43/B.15	LB3DR	112665	A.43
GPAPU20LTAAR	101348	C.8	GPS1BHAG	101247	C.3	LB1DB	112310	A.43/B.15	LB3DT	112666	A.43
GPAPU20LTAAU	101349	C.8	GPS1BHAB	101248	C.3	LB1DD	112316	A.43/B.15	LB3DWB	113530	A.43
GPAPU20LTAAY	101350	C.8	GPS1BSAA	101211	C.3	LB1DE	112650	A.43/B.15	LB3DWD	113531	A.43
GPAPU20LTAAY	101351	C.8	GPS1BSAB	101212	C.3	LB1DF	112651	A.43/B.15	LB3DWE	113532	A.43
GPAPU20LTAAY	101351	C.8	GPS1BSAC	101213	C.3	LB1DH	112652	A.43/B.15	LB3DYG	113533	A.43
GPAPU20LTAAY	101351	C.8	GPS1BSAD	101214	C.3	LB1DI	112653	A.43/B.15	LB3DWI	113534	A.43

Alphabetical index

Intro

A

B

C

D

E

F

G

H

I

X



Controls Alphabetical Index

Alphabetical index

Intro

A

B

C

D

E

F

G

H

I

X

Cat. no.	Ref. no	Cat. pg	Cat. no.	Ref. no	Cat. pg	Cat. no.	Ref. no	Cat. pg	Cat. no.	Ref. no	Cat. pg
LB3DJW	113535	A.43	LG0406R1B0	133265	A.46	M80CJG	137287	A.34/B.9	MC1A310AT6	102622	A.34
LB3DWN	113536	A.43	LG0406S1B0	116997	A.46	M80CLE	133186	A.34/B.9	MC1A310AT6MPP	100249	A.34
LB4A1	110482	A.43	LG2504P1B0	100885	A.46	M80CNG	137289	A.34/B.9	MC1A310AT7	102623	A.34
LB4A12G	116816	A.43	LG2506P1B0	110095	A.46	M80CWD	137286	A.34/B.9	MC1A310AT9	100298	A.34
LB4A13	247962	A.43	LG2506R1B0	133611	A.46	M80CWF	137285	A.34/B.9	MC1A310ATJ	100213	A.34
LB4A13G	116819	A.43	LR1A1	101087	B.15	M80CWJ	102497	A.34/B.9	MC1A310ATK	102610	A.34
LB4A15	110387	A.43	LR1AL	101088	B.15	M80A1	102407	A.34/B.9	MC1A310ATM	102611	A.34
LB4A1G	116601	A.43	LR1AN	108909	B.15	M80A4	102410	A.34/B.9	MC1A310ATN	100214	A.34
LB4A1MP	108144	A.43	LR1AU	101090	B.15	M80A6	102412	A.34/B.9	MC1A310ATNMP	103980	A.34
LB4A2	110483	A.43	LR1AV	101091	B.15	M80AC	102396	A.34/B.9	MC1A310ATU	100215	A.34
LB4A2G	116802	A.43	LR1DD	101031	B.15	M80AD	100451	A.34/B.9	MC1A310ATW	102615	A.34
LB4A3	110484	A.43	LR1DK	101092	B.15	M80AE	102397	A.34/B.9	MC1A310ATY	102616	A.34
LB4A32G	116813	A.43	LR1DWD	112330	B.15	M80AG	100452	A.34/B.9	MC1A310GFF	290188	A.34
LB4A3G	116602	A.43	LR1DWE	112331	B.15	M80AJ	100453	A.34/B.9	MC1A310GFN	137373	A.34
LB4A4	110485	A.43	LR1DWG	112332	B.15	M80AM	102401	A.34/B.9	MC1A310GFU	290171	A.34
LB4A5	110486	A.43	LR1DWI	112333	B.15	M80AN	100454	A.34/B.9	MC1A310GHU	102688	A.34
LB4A6	110487	A.43	LR1DWJ	112334	B.15	M80AS	102403	A.34/B.9	MC1A310GI1	125838	A.34
LB4A6G	116600	A.43	MACL101AF	100563	A.38	M80AU	213532	A.34/B.9	MC1A310GI9	102646	A.34
LB4A6MP	108146	A.43	MACL101AI	100565	A.38	M80AW	102405	A.34/B.9	MC1A310GIU	290364	A.34
LB4A7	110488	A.43	MACL101AR	103556	A.38	M80AY	102406	A.34/B.9	MC1A310JHC	125834	A.34
LB4A7G	116801	A.43	MACL101AT	100561	A.38	M80CA	102415	A.34/B.9	MC1A310JTI	125843	A.34
LB4A8	110489	A.43	MACL110AF	100562	A.38	M80CB	100460	A.34/B.9	MC1A310MT1	125551	A.34
LB4A8G	110483	A.43	MACL110AI	100564	A.38	M80CC	102416	A.34/B.9	MC1A400AF1	103049	A.36
LB4A9	113322	A.43	MACL110AR	103555	A.38	M80CD	100466	A.34/B.9	MC1A400AF2	103050	A.36
LB4A9G	136752	A.43	MACL110AT	100560	A.38	M80CF	102418	A.34/B.9	MC1A400AF6	103054	A.36
LB4AD	104651	A.43	MACN202AR	103558	A.37	M80CG	100467	A.34/B.9	MC1A400AFJ	100393	A.36
LB4ADG	136915	A.43	MACN202AT	100998	A.37	M80CH	102419	A.34/B.9	MC1A400AFN	100394	A.36
LB4AE	110467	A.43	MACN211AR	103557	A.37	M80CI	102420	A.34/B.9	MC1A400AFH	100387	A.36
LB4AF	110468	A.43	MACN211AT	100999	A.37	M80CJ	100468	A.34/B.9	MC1A400AI1	103112	A.36
LB4AFG	116604	A.43	MACN400AT	100199	A.37	M80CK	102421	A.34/B.9	MC1A400AI6	100188	A.36
LB4AHG	116795	A.43	MACN413AR	103561	A.37	M80CL	102422	A.34/B.9	MC1A400AI9	100189	A.36
LB4AJ	104653	A.43	MACN413AT	100995	A.37	M80CN	100469	A.34/B.9	MC1A400AII	100423	A.36
LB4AJG	116605	A.43	MACN422AR	103560	A.37	M80CR	102423	A.34/B.9	MC1A400AIM	101708	A.36
LB4AJMP	108148	A.43	MACN422AT	100996	A.37	M80CS	100449	A.34/B.9	MC1A400AIN	100424	A.36
LB4AK	110471	A.43	MACN431AR	103559	A.37	M80KD	100471	A.34/B.9	MC1A400AIO	100425	A.36
LB4AL	110472	A.43	MACN431AT	100997	A.37	MC1A301AF1	102680	A.34	MC1A400AIY	295150	A.36
LB4ALJ	125769	A.43	MAGL110AT	100608	A.38	MC1A301AF2	102681	A.34	MC1A400AT1	102986	A.36
LB4AMG	116799	A.43	MAGL101AFS	100522	A.38	MC1A301AF6	102685	A.34	MC1A400AT2	102987	A.36
LB4AN	104654	A.43	MARL101AI	100518	A.38	MC1A301AFJ	100243	A.34	MC1A400AT6	102991	A.36
LB4ANG	116599	A.43	MARL101AIS	100524	A.38	MC1A301AFN	100244	A.34	MC1A400AT7	102992	A.36
LB4AR	110475	A.43	MARL101ARS	103298	A.38	MC1A301AFU	100109	A.34	MC1A400AT9	100296	A.36
LB4ARG	116603	A.43	MARL101AT	100514	A.38	MC1A301AFW	102678	A.34	MC1A400ATJ	100363	A.36
LB4AS	110474	A.43	MARL101ATS	100520	A.38	MC1A301AH6	116938	A.34	MC1A400ATJMP	103989	A.36
LB4ASJ	125772	A.43	MARL110AF	100515	A.38	MC1A301AI1	102722	A.34	MC1A400ATK	102979	A.36
LB4AT	110476	A.43	MARL110AFS	100521	A.38	MC1A301AI6	107167	A.34	MC1A400ATM	102980	A.36
LB4ATG	292981	A.43	MARL110AI	100517	A.38	MC1A301AI9	100149	A.34	MC1A400ATN	100364	A.36
LB4AU	104655	A.43	MARL110AIS	100523	A.38	MC1A301AIJ	100263	A.34	MC1A400ATNMP	103988	A.36
LB4AUG	116796	A.43	MARL110AR	103356	A.38	MC1A301AIU	100264	A.34	MC1A400ATU	100365	A.36
LB4AUMP	108152	A.43	MARL110ARS	103299	A.38	MC1A301AIU	100265	A.34	MC1A400ATW	102984	A.36
LB4AV	110477	A.43	MARL110AT	100513	A.38	MC1A301AR1	103399	A.34	MC1A400ATY	102985	A.36
LB4AVG	136880	A.43	MARL110ATS	100519	A.38	MC1A301AR9	103400	A.34	MC1A400G15	290489	A.36
LB4AW	110478	A.43	MARN202AR	103351	A.37	MC1A301ARJ	100175	A.34	MC1A400G18	290482	A.36
LB4AWG	116798	A.43	MARN202AT	100992	A.37	MC1A301ARN	103403	A.34	MC1A400AF2	103092	A.36
LB4AX	110479	A.43	MARN211AR	103350	A.37	MC1A301ARU	103404	A.34	MC1A400AF7	100413	A.36
LB4AY	110480	A.43	MARN211AT	100993	A.37	MC1A301AT1	102638	A.34	MC1A400ATH	100190	A.36
LB4AYG	116797	A.43	MARN220AR	103349	A.37	MC1A301AT2	102639	A.34	MC1A400AFU	100207	A.36
LB4AZ	110481	A.43	MARN220AT	100994	A.37	MC1A301AT6	102643	A.34	MC1A400AIN	100208	A.36
LB4DWB	103794	A.43	MARN400AR	103300	A.37	MC1A301AT7	102644	A.34	MC1A400AIU	100302	A.36
LB4DVBG	103798	A.43	MARN400AT	100987	A.37	MC1A301AT9	100320	A.34	MC1A400AT1	103028	A.36
LB4DWD	103744	A.43	MARN413AR	103355	A.37	MC1A301ATJ	100223	A.34	MC1A400AT2	103029	A.36
LB4DWDG	103791	A.43	MARN413AT	100988	A.37	MC1A301ATJ-B	220352	A.34	MC1A400AT6	103033	A.36
LB4DWE	103745	A.43	MARN422AR	103354	A.37	MC1A301ATN	100224	A.34	MC1A400AT9	100305	A.36
LB4DWEG	103792	A.43	MARN422AT	100989	A.37	MC1A301ATNMP	103982	A.34	MC1A400ATH	103019	A.36
LB4DWGG	103799	A.43	MARN431AR	103353	A.37	MC1A301ATU	100225	A.34	MC1A400ATF	103020	A.36
LB4DWI	103796	A.43	MARN431AT	100990	A.37	MC1A301ATW	102636	A.34	MC1A400ATJ	100383	A.36
LB4DWIG	103800	A.43	MARN440AR	103352	A.37	MC1A301ATY	102637	A.34	MC1A400ATK	103021	A.36
LB4DWJ	103746	A.43	MARN440AT	100991	A.37	MC1A301ATY	290238	A.34	MC1A400ATM	103022	A.36
LB4DWJG	103793	A.43	MATV10AT	110122	A.53	MC1A301GI1	290403	A.34	MC1A400ATM-B	220377	A.36
LB4DWN	103797	A.43	M80A10	100450	A.34/B.9	MC1A301G1U	290428	A.34	MC1A400ATN	100384	A.36
LB4DWNG	103801	A.43	M80A16	102367	A.34/B.9	MC1A301GIN	290397	A.34	MC1A400ATU	100385	A.36
LB4EBWH	104119	A.43	M80A19G	293071	A.34/B.9	MC1A310AF1	102659	A.34	MC1A400ATV	100308	A.36
LB4ED	112336	A.43	M80A1E	209469	A.34/B.9	MC1A310AF2	102660	A.34	MC1A400AFK	103063	A.36
LB4EDG	201542	A.43	M80A1G	136013	A.34/B.9	MC1A310AF6	102664	A.34	MC1A400AFN	100310	A.36
LB4EF	112670	A.43	M80A3	102409	A.34/B.9	MC1A310AFJ	100179	A.34	MC1A400ATU	100405	A.36
LB4EH	112672	A.43	M80A5	102411	A.34/B.9	MC1A310AFN	100234	A.34	MC1A400AI9	100312	A.36
LB4EJ	112338	A.43	M80A7	102413	A.34/B.9	MC1A310AFU	100235	A.34	MC1A400AIJ	100433	A.36
LB4EJG	137093	A.43	M80A8	102414	A.34/B.9	MC1A310AH6	116492	A.34	MC1A400AIN	100434	A.36
LB4EN	112339	A.43	M80A9	133717	A.34/B.9	MC1A310AHU	116494	A.34	MC1A400AIU	100322	A.36
LB4ENG	135787	A.43	M80ACG	293075	A.34/B.9	MC1A310AHUMP	116474	A.34	MC1A400AT1	103007	A.36
LB4EWD	113537	A.43	M80ADG	133275	A.34/B.9	MC1A310AI1	102701	A.34	MC1A400AT2	103008	A.36
LB4EWE	113538	A.43	M80AFG	133276	A.34/B.9	MC1A310AI6	101707	A.34	MC1A400AT6	103012	A.36
LB4EWF	113539	A.43	M80AGG	293077	A.34/B.9	MC1A310AI9	100180	A.34	MC1A400AT7	103013	A.36
LB4EWH	113540	A.43	M80AJG	133277	A.34/B.9	MC1A310AIJ	100253	A.34	MC1A400AT9	100400	A.36
LB4EWJ	113541	A.43	M80AK	102400	A.34/B.9	MC1A310AIK	100439	A.34	MC1A400ATC	102996	A.36
LB4EWN	113542	A.43	M80AME	133385	A.34/B.9	MC1A310AIN	100254	A.34	MC1A400ATE	102997	A.36
LB4EY	113972	A.43	M80ANE	209482	A.34/B.9	MC1A310AIU	100255	A.34	MC1A400ATF	102998	A.36
LG0004P1B0	209344	A.46	M80ANJ	125817	A.34/B.9	MC1A310AIW	102699	A.34	MC1A400ATH	102999	A.36
LG0004R1B0	116651	A.46	M80ANM	125371	A.34/B.9	MC1A310IAR1	103386	A.34	MC1A400ATJ	100373	A.36
LG0004S1B0	209347	A.46	M80AO	116400	A.34/B.9	MC1A310IAR9	103387	A.34	MC1A400ATJMP	103991	A.36
LG0006P1B0	200004	A.46	M80ARG	133631	A.34/B.9	MC1A310IARJ	100182	A.34	MC1A400ATN	100300	A.36
LG0006R1B0	116652	A.46	M80ATJ	125820	A.34/B.9	MC1A310IARU	103390	A.34	MC1A400ATM	103001	A.36
LG0006S1B0	116011	A.46	M80AUG	133278	A.34/B.9	MC1A310IARN	103391	A.34	MC1A400ATN	100374	A.36
LG0040P1B0	116653	A.46	M80AWM	137191	A.34/B.9	MC1A310IAT1	102617	A.34	MC		

Controls Alphabetical Index

Cat. no.	Ref. no	Cat. pg	Cat. no.	Ref. no	Cat. pg	Cat. no.	Ref. no	Cat. pg	Cat. no.	Ref. no	Cat. pg
MCIAB00ATU	100375	A.36	MCIK301ATD	100577	A.35	MC2C310FRD	139757	A.34	MCR031ATY	102033	B.9
MCIAB00ATW	103005	A.36	MCIK310ARD	103446	A.35	MC2C310FRG	139758	A.34	MCR031MTJ	100486	B.9
MCIAB00ATY	103006	A.36	MCIK310ATD	100576	A.35	MC2C310FRJ	139763	A.34	MCR0400AFJ	107095	B.9
MCIAB00G1I	290518	A.36	MCIK400ATD	100569	A.35	MC2C310FRN	139767	A.34	MCR0400AFM	100087	B.9
MCIAB00G4I	290522	A.36	MC2A301A1I	203273	A.34	MC2C400ATD	116178	A.36	MCR0400AFN	100054	B.9
MCIAB00GIN	290512	A.36	MC2A301AIN	101019	A.34	MC2C400ATJ	116180	A.36	MCR0400AFU	100055	B.9
MCI1C301AFD	100246	A.34	MC2A301AR1	103425	A.34	MC2C400ATWN	100445	A.36	MCR0400AH1	102105	B.9
MCI1C301AFG	100440	A.34	MC2A301AR9	103426	A.34	MC2C800ARVD	135686	A.36	MCR0400A1I	101672	B.9
MCI1C301AFJ	100248	A.34	MC2A301ARJ	103427	A.34	MC2C800ATD	135700	A.36	MCR0400A1J	100103	B.9
MCI1C301AID	100266	A.34	MC2A301ARN	103429	A.34	MC2C800ATWL	204888	A.36	MCR0400A1K	100104	B.9
MCI1C301ARWD	101710	A.34	MC2A301ARU	103430	A.34	MC2I301ATD	100538	A.35	MCR0400ARN	103305	B.9
MCI1C301ARWI	201564	A.34	MC2A301AT1	103569	A.34	MC2I310ATD	100559	A.35	MCR0400AT1	102013	B.9
MCI1C301ARWJ	101714	A.34	MC2A301AT2	103253	A.34	MC2K301ARD	103449	A.35	MCR0400AT2	102014	B.9
MCI1C301ARWL	100327	A.34	MC2A301AT5MP	247956	A.34	MC2K301ATD	103591	A.35	MCR0400AT4	102016	B.9
MCI1C301ATB	100220	A.34	MC2A301AT6	103571	A.34	MC2K301FRD	139798	A.35	MCR0400AT6	102018	B.9
MCI1C301ATD	100226	A.34	MC2A301AT9	103269	A.34	MC2K310ATD	103590	A.35	MCR0400AT7	102019	B.9
MCI1C301ATDD	113328	A.34	MC2A301ATJ	103565	A.34	MC2K310ATWG	103592	A.35	MCR0400AT9	108237	B.9
MCI1C301ATDV	100118	A.34	MC2A301ATM	100046	A.34	MC2K310FRG	139797	A.35	MCR0400ATJ	100003	B.9
MCI1C301ATE	102741	A.34	MC2A301ATN	103566	A.34	MC2K800ATWG	103596	A.35	MCR0400ATK	102006	B.9
MCI1C301ATG	100227	A.34	MC2A301ATU	103567	A.34	MCR0004AFJ	100092	A.36	MCR0400ATM	102007	B.9
MCI1C301ATH	102743	A.34	MC2A301ATW	135705	A.34	MCR0004AFN	100094	B.9	MCR0400ATN	100004	B.9
MCI1C301ATJ	100228	A.34	MC2A301FR1	139768	A.34	MCR0004A1I	100499	B.9	MCR0400ATP	100005	B.9
MCI1C301ATWD	102377	A.34	MC2A301FR24	139770	A.34	MCR0004A1J	100144	A.34	MCR0400ATW	102011	B.9
MCI1C301ATWG	100409	A.34	MC2A301FR25	139774	A.34	MCR0004A1U	100145	B.9	MCR0400ATY	102012	B.9
MCI1C301ATWG-B	200795	A.34	MC2A301FR29	139771	A.34	MCR0004AT1	102097	B.9	MCR022AFD	100076	B.9
MCI1C301ATWI	100357	A.34	MC2A301FR30	139773	A.34	MCR0004AT2	102098	B.9	MCR022AFWL	100494	B.9
MCI1C301ATWJ-B	220370	A.34	MC2A301FR9	139769	A.34	MCR0004AT6	102102	B.9	MCR022AID	100126	B.9
MCI1C301ATWL-B	220459	A.34	MC2A301FRJ	139772	A.34	MCR0004AT7	102103	B.9	MCR022AIWS	100495	B.9
MCI1C301ATWN-B	220368	A.34	MC2A301FRN	139775	A.34	MCR0004AT9	108859	B.9	MCR022ARVD	100069	B.9
MCI1C301ATWS-B	220358	A.34	MC2A301FRU	139777	A.34	MCR0004ATJ	100043	B.9	MCR022ARWJ	102494	B.9
MCI1C301GID	125848	A.34	MC2A310AFJ	135683	A.34	MCR0004ATK	102090	B.9	MCR022ATB	100020	B.9
MCI1C301OAFB	100230	A.34	MC2A310AFM	135687	A.34	MCR0004ATM	102091	B.9	MCR022ATD	100026	B.9
MCI1C301OAFD	100236	A.34	MC2A310AHJ	135684	A.34	MCR0004ATN	100044	B.9	MCR022ATDD	113324	B.9
MCI1C301OAFI	100256	A.34	MC2A310AIN	101018	A.34	MCR0004ATU	100045	B.9	MCR022ATDV	100568	B.9
MCI1C301OAFJ	100257	A.34	MC2A310AR1	103412	A.34	MCR0004ATW	102095	B.9	MCR022ATE	102334	B.9
MCI1C301OARD	100429	A.34	MC2A310AR9	103413	A.34	MCR0004ATY	102096	B.9	MCR022ATG	100027	B.9
MCI1C301OARWJ	101713	A.34	MC2A310ARJ	103414	A.34	MCR0013AF1	101653	B.9	MCR022ATH	102336	B.9
MCI1C301OATB	100210	A.34	MC2A310ARN	103416	A.34	MCR0013AF6	100479	B.9	MCR022ATJ	100028	B.9
MCI1C301OATD	100216	A.34	MC2A310ARU	103417	A.34	MCR0013AFN	100084	B.9	MCR022ATWD	102485	B.9
MCI1C301OATDD	113312	A.34	MC2A310AT1	103577	A.34	MCR0013A1I	101654	B.9	MCR022ATWG	100082	B.9
MCI1C301OATDV	100117	A.34	MC2A310AT2	135682	A.34	MCR0013A1J	100133	B.9	MCR022ATWI	100496	B.9
MCI1C301OATE	102732	A.34	MC2A310AT6	103579	A.34	MCR0013A1N	100134	B.9	MCR022ATWJ	101711	B.9
MCI1C301ATG	100217	A.34	MC2A310AT9	103268	A.34	MCR0013AT1	102076	B.9	MCR022ATWL-B	220456	B.9
MCI1C301ATJ	100218	A.34	MC2A310ATC	135703	A.34	MCR0013AT2	102077	B.9	MCR022ATWN	100070	B.9
MCI1C301ATWD	102376	A.34	MC2A310ATJ	103573	A.34	MCR0013AT4	102079	B.9	MCR022ATWN-B	220402	B.9
MCI1C301ATWG	100380	A.34	MC2A310ATK	135685	A.34	MCR0013AT5MP	247957	B.9	MCR022ATWS-B	220441	B.9
MCI1C301ATWH-B	200793	A.34	MC2A310ATM	103835	A.34	MCR0013AT6	102081	B.9	MCR022MTG	133755	B.9
MCI1C301ATWI	100356	A.34	MC2A310ATN	103574	A.34	MCR0013AT7	102082	B.9	MCR031AFD	100066	B.9
MCI1C301ATWJ-B	220371	A.34	MC2A310ATU	103575	A.34	MCR0013AT9	102359	B.9	MCR031AFJ	100086	B.9
MCI1C301ATWL-B	220460	A.34	MC2A310ATW	135704	A.34	MCR0013ATJ	100033	B.9	MCR031AFWN	100529	B.9
MCI1C301ATWN	247309	A.34	MC2A310FR1	139744	A.34	MCR0013ATM	102070	B.9	MCR031AID	100116	B.9
MCI1C301ATWN-B	220369	A.34	MC2A310FR24	139746	A.34	MCR0013ATN	100034	B.9	MCR031AIG	100100	B.9
MCI1C301ATWS-B	200792	A.34	MC2A310FR27	139754	A.34	MCR0013ATU	100035	B.9	MCR031ARWD	102346	B.9
MCI1C301JTB	125659	A.34	MC2A310FR29	139747	A.34	MCR0022AFG	100072	B.9	MCR031ARWE	102360	B.9
MCI1C301JTD	125849	A.34	MC2A310FR30	139749	A.34	MCR0022AFJ	100073	B.9	MCR031ARWJ	102493	B.9
MCI1C400AFD	100396	A.36	MC2A310FR9	139745	A.34	MCR0022AFN	100074	B.9	MCR031ATB	100010	B.9
MCI1C400AFWN	100330	A.36	MC2A310FRJ	139748	A.34	MCR0022AFW	100481	B.9	MCR031ATD	100016	B.9
MCI1C400AIB	100420	A.36	MC2A400AT1	101645	A.36	MCR0022A1I	100482	B.9	MCR031ATDD	113325	B.9
MCI1C400AID	100426	A.36	MC2A400AT6	103595	A.36	MCR0022A1J	100123	B.9	MCR031ATDV	100567	B.9
MCI1C400AIWN	100332	A.36	MC2A400AT7	116194	A.36	MCR0022A1N	100124	B.9	MCR031ATE	102325	B.9
MCI1C400ARWD	102543	A.36	MC2A400ATJ	116184	A.36	MCR0022A1U	100125	B.9	MCR031ATG	100017	B.9
MCI1C400ARWI	100389	A.36	MC2A400ATN	116177	A.36	MCR0022ARJ	100485	B.9	MCR031ATJ	100018	B.9
MCI1C400ARWJ	200003	A.36	MC2A400ATU	103292	A.36	MCR0022ARU	103318	B.9	MCR031ATWD	102348	B.9
MCI1C400ATB	100360	A.36	MC2A400ATW	116193	A.36	MCR0022AT1	102055	B.9	MCR031ATWG	100083	B.9
MCI1C400ATD	100366	A.36	MC2AB00AT1	101648	A.36	MCR0022AT2	102056	B.9	MCR031ATWI	100582	B.9
MCI1C400ATG	100367	A.36	MC2AB00AT6	103027	A.36	MCR0022AT4	102058	B.9	MCR031ATWJ	101710	B.9
MCI1C400ATH	103220	A.36	MC2AB00AT9	248068	A.36	MCR0022AT6	102060	B.9	MCR031ATWJ-B	220406	B.9
MCI1C400ATJ	100368	A.36	MC2AB00ATJ	110548	A.36	MCR0022AT7	102061	B.9	MCR031ATWL-B	220457	B.9
MCI1C400ATWD	102387	A.36	MC2AB00ATN	135699	A.36	MCR0022AT9	108236	B.9	MCR031ATWN-B	220403	B.9
MCI1C400ATWI	100358	A.36	MC2AB00ATW	247441	A.36	MCR0022ATJ	100023	B.9	MCR031ATWS-B	220442	B.9
MCI1C400ATWJ	102389	A.36	MC2C301AID	247948	A.34	MCR0022ATK	102048	B.9	MCR040AFD	100056	B.9
MCI1C400ATWL-B	220462	A.36	MC2C301ARVD	100438	A.34	MCR0022ATM	102049	B.9	MCR040AFG	100057	B.9
MCI1C400ATWN-B	220340	A.36	MC2C301ATB	103589	A.34	MCR0022ATN	100024	B.9	MCR040AFJ	100088	B.9
MCI1C400ATWS-B	220359	A.36	MC2C301ATD	103580	A.34	MCR0022ATU	100025	B.9	MCR040AFWL	100583	B.9
MCI1C400GID	133164	A.36	MC2C301ATDMP	103023	A.34	MCR0022ATW	102053	B.9	MCR040AFWN	100588	B.9
MCI1C800AFD	100406	A.36	MC2C301ATDV	100566	A.34	MCR0022ATY	102054	B.9	MCR040AID	102332	B.9
MCI1C800AID	100436	A.36	MC2C301ATG	103581	A.34	MCR0031AF1	101662	B.9	MCR040ARWD	100528	B.9
MCI1C800AIWJD	247772	A.36	MC2C301ATWD	102379	A.34	MCR0031AF6	102354	B.9	MCR040ARWJ	102492	B.9
MCI1C800ARWD	100580	A.36	MC2C301ATWJ	102382	A.34	MCR0031AFJ	107089	B.9	MCR040ATB	100000	B.9
MCI1C800ARWJ	200002	A.36	MC2C301ATWL	204886	A.34	MCR0031AFN	100064	B.9	MCR040ATD	100006	B.9
MCI1C800ATB	100352	A.36	MC2C301ATWN	100435	A.34	MCR0031A1I	101665	B.9	MCR040ATDD	113311	B.9
MCI1C800ATD	100376	A.36	MC2C310ARD	103419	A.34	MCR0031A1J	100113	B.9	MCR040ATE	102316	B.9
MCI1C800ATG	100377	A.36	MC2C310ARVD	100430	A.34	MCR0031AIN	100114	B.9	MCR040ATG	100007	B.9
MCI1C800ATJ	100378	A.36	MC2C310ARWJ	101716	A.34	MCR0031AT1	102034	B.9	MCR040ATJ	100008	B.9
MCI1C800ATL	101717	A.36	MC2C310ATB	103588	A.34	MCR0031AT2	102035	B.9	MCR040ATWD	102484	B.9
MCI1C800ATWD	102388	A.36	MC2C310ATD	103584	A.34	MCR0031AT4	102037	B.9	MCR040ATWI	100590	B.9
MCI1C800ATWI	100359	A.36	MC2C310ATDD	116181	A.34	MCR0031AT6	102039	B.9	MCR040ATWJ	101719	B.9
MCI1C800ATWJ	102390	A.36	MC2C310ATDV	100558	A.34	MCR0031AT7	102040	B.9	MCR040ATWL-B	220458	B.9
MCI1C800ATWL-B	220461	A.36	MC2C310ATG	103585	A.34	MCR0031AT9	108238	B.9	MCR040ATWN-B	103022	B.9
MCI1C800ATWN-B	220341	A.36	MC2C310ATJ	103586	A.34	MCR0031ATJ	100013	B.9	MCR040ATWN	102572	B.9
MCI1C800ATWS-B	220392	A.36	MC2C310ATWD	102378	A.34	MCR0031ATK	1020				

Controls Alphabetical Index

Alphabetical index

Cat. no.	Ref. no	Cat. pg	Cat. no.	Ref. no	Cat. pg	Cat. no.	Ref. no	Cat. pg	Cat. no.	Ref. no	Cat. pg
MCRK022ARD	100540	B.9	P9ACPBS109	188109	F.36	P9ACPBS703	188703	F.36	P9ARBGN030	187145	F.32
MCRK022ATD	100535	B.9	P9ACPBS110	188110	F.36	P9ACPBS704	188704	F.36	P9ARBGN031	187133	F.32
MCRK022ATWG	103594	B.9	P9ACPBS111	188111	F.36	P9ACPBS705	188705	F.36	P9ARBGN032	187135	F.32
MCRK031AT1	100669	B.9	P9ACPBS112	188112	F.36	P9ACPBS706	188706	F.36	P9ARBGN035	187113	F.32
MCRK031ATD	100534	B.9	P9ACPBS113	188113	F.36	P9ACPBS707	188707	F.36	P9ARBGN038	187115	F.32
MCRK031ATWG	103593	B.9	P9ACPBS114	188114	F.36	P9ACPBS708	188708	F.36	P9ARBGN085	188886	F.32
MCRK040ATD	100533	B.9	P9ACPBS115	188115	F.36	P9ACPBS713	188713	F.36	P9ARBGN201	188908	F.32
MCRK040ATDD	117220	B.9	P9ACPBS116	188116	F.36	P9ACPBS714	188714	F.36	P9ARBGN202	187148	F.32
MMHO	100547		P9ACPBS117	188117	F.36	P9ACPBS715	188715	F.36	P9ARBRG	187101	F.32
MPOAAE1	100544	A.39	P9ACPBS118	188118	F.36	P9ACPBS719	188719	F.36	P9ARBRG029	187110	F.32
MPOAAE2	100545	A.39	P9ACPBS119	188119	F.36	P9ACPBS720	188720	F.36	P9ARBRG036	187144	F.32
MPOCAE3	100546	A.39	P9ACPBS120	188120	F.36	P9ACPBS722	188722	F.36	P9ARBRG201	187147	F.32
MPODAE4	100536	A.39	P9ACPBS121	188121	F.36	P9ACPIIT	188029		P9ARBGV	187102	F.32
MPODAE5	204848	A.39	P9ACPBS122	188122	F.36	P9ACPIU	188016	F.36	P9ARBGV001	187138	F.32
MPODAE6	204849	A.39	P9ACPBS123	188123	F.36	P9ACPTS	188018		P9ARBGV002	187140	F.32
MT03A	101000	A.53	P9ACPBS124	188124	F.36	P9ACPWV	188017		P9ARBGV006	187118	F.32
MT03B	101001	A.53	P9ACPBS125	188125	F.36	P9ACRCL	187840		P9ARBGV012	187120	F.32
MT03C	101002	A.53	P9ACPBS126	188126	F.36	P9ACT00	242650		P9ARBGV013	187122	F.32
MT03D	101003	A.53	P9ACPBS127	188127	F.36	P9ACVLR	187844		P9ARBGV014	187124	F.32
MT03E	101004	A.53	P9ACPBS129	188129	F.36	P9ACWAF	187845		P9ARBGV017	187126	F.32
MT03F	101005	A.53	P9ACPBS130	188130	F.36	P9ADCT	187796	F.15	P9ARBGV018	187128	F.32
MT03G	101006	A.53	P9ACPBS131	188131	F.36	P9AELN	189030	F.28	P9ARBGV026	187130	F.32
MT03H	101007	A.53	P9ACPBS132	188132	F.36	P9AELN006	189041	F.28	P9ARBGV027	187132	F.32
MT03I	101008	A.53	P9ACPBS134	188134	F.36	P9AELN028	189042	F.28	P9ARBGV028	187112	F.32
MT03J	101009	A.53	P9ACPBS137	188137	F.36	P9AELN029	189043	F.28	P9ARBGV030	187146	F.32
MT03K	101010	A.53	P9ACPBS138	188138	F.36	P9AELN035	189044	F.28	P9ARBGV031	187134	F.32
MT03L	101011	A.53	P9ACPBS139	188139	F.36	P9AELN038	189045	F.28	P9ARBGV032	187136	F.32
MT03M	101012	A.53	P9ACPBS140	188140	F.36	P9AELN039	189046	F.28	P9ARBGV035	187114	F.32
MT03N	101013	A.53	P9ACPBS142	188142	F.36	P9AELN042	189047	F.28	P9ARBGV038	187116	F.32
MT03P	101014	A.53	P9ACPBS143	188143	F.36	P9AELN101	189048	F.28	P9ARBGV202	187149	F.32
MT03R	101015	A.53	P9ACPBS144	188144	F.36	P9AELN102	189049	F.28	P9ARBSB	187207	F.32
MT03RA	103540	A.53	P9ACPBS145	188145	F.36	P9AELN106	189051	F.28	P9ARBSG	187203	F.32
MT03RB	103541	A.53	P9ACPBS146	188146	F.36	P9AELN112	189052	F.28	P9ARBSH	187208	F.32
MT03RC	103542	A.53	P9ACPBS147	188147	F.36	P9AELN120	189054	F.28	P9ARBSL	187206	F.32
MT03RD	103543	A.53	P9ACPBS148	188148	F.36	P9AELN122	189055	F.28	P9ARBSL037	187243	F.32
MT03RE	103544	A.53	P9ACPBS151	188151	F.36	P9AELN201	189032	F.28	P9ARBSN	187200	F.32
MT03RF	103545	A.53	P9ACPBS153	188153	F.36	P9AELN202	189031	F.28	P9ARBSN006	187217	F.32
MT03RG	103546	A.53	P9ACPBS154	188154	F.36	P9AELN203	189038	F.28	P9ARBSN017	187225	F.32
MT03RH	103547	A.53	P9ACPBS155	188155	F.36	P9AELN204	189037	F.28	P9ARBSN018	187227	F.32
MT03RI	103548	A.53	P9ACPBS156	188156	F.36	P9AELN205	189035	F.28	P9ARBSN028	187211	F.32
MT03RJ	103549	A.53	P9ACPBS159	188159	F.36	P9AELN206	189036	F.28	P9ARBSN029	187250	F.32
MT03RK	103550	A.53	P9ACPBS160	188160	F.36	P9AELN212	189058	F.28	P9ARBSN030	187245	F.32
MT03RL	103551	A.53	P9ACPBS162	188162	F.36	P9AELN213	189059	F.28	P9ARBSN032	187235	F.32
MT03RM	103552	A.53	P9ACPBS163	188163	F.36	P9AELN214	189033	F.28	P9ARBSN035	187213	F.32
MT03RN	103553	A.53	P9ACPBS201	188201	F.36	P9AELN215	189034	F.28	P9ARBSN202	187248	F.32
MT03RP	103554	A.53	P9ACPBS202	188202	F.36	P9AELN222	189152	F.28	P9ARBSR	187201	F.32
MT0AD	101026	A.53	P9ACPBS203	188203	F.36	P9AELN224	189154	F.28	P9ARBSR029	187210	F.32
MT0AF	101028	A.53	P9ACPBS204	188204	F.36	P9AELN309	189068	F.28	P9ARBSR036	187244	F.32
MT0AH	101030	A.53	P9ACPBS205	188205	F.36	P9AELN316	189070	F.28	P9ARBSR201	187247	F.32
MT0AK	101032	A.53	P9ACPBS206	188206	F.36	P9AELN406	189077	F.28	P9ARBSV	187202	F.32
MVB0L	101830		P9ACPBS212	188212	F.36	P9AELN510	189094	F.28	P9ARBSV001	187238	F.32
MVB0R	100543	A.39	P9ACPBS214	188214	F.36	P9AELN511	189095	F.28	P9ARBSV006	187218	F.32
MVB0T	101021	A.53	P9ACPBS215	188215	F.36	P9AELN707	189133	F.28	P9ARBSV028	187212	F.32
MVE0R	103562	A.53	P9ACPBS218	188218	F.36	P9AELN708	189134	F.28	P9ARBSV030	187246	F.32
MVE0T	101020	A.53	P9ACPBS222	188222	F.36	P9ARADE	188800	F.32	P9ARBSV032	187236	F.32
MVPOC	100600	A.39	P9ACPBS224	188224	F.36	P9ARAM32	188801	F.36	P9ARBSV035	187214	F.32
P9ACA6	188804	F.24	P9ACPBS226	188226	F.36	P9ARAND	188802	F.32	P9ARBSV202	187249	F.32
P9ACB4N	187800		P9ACPBS227	188227	F.36	P9ARAX32	188803	F.32	P9ARCT	187490	F.21
P9ACB4R	187801		P9ACPBS229	188229	F.36	P9ARB3G	187403	F.32	P9ARDLS	187300	
P9ACB4V	187802		P9ACPBS231	188231	F.36	P9ARB3N	187400	F.32	P9ARDLS001	187315	F.33
P9ACDPP	187843	F.34	P9ACPBS232	188232	F.36	P9ARB3R	187401	F.32	P9ARDLS002	187316	F.33
P9ACFS3	187841	F.34	P9ACPBS233	188233	F.36	P9ARB3V	187402	F.32	P9ARDLS005	187317	F.33
P9ACFS5	187842	F.34	P9ACPBS234	188234	F.36	P9ARB4G	187413	F.32	P9ARDLS006	187305	F.33
P9ACFSM	187846	F.24	P9ACPBS239	188239	F.36	P9ARB4N	187410	F.32	P9ARDLS012	187306	F.33
P9ACGP4B	187827		P9ACPBS240	188240	F.36	P9ARB4R	187411	F.32	P9ARDLS013	187307	F.33
P9ACGP4G	187823		P9ACPBS243	188243	F.36	P9ARB4V	187412	F.32	P9ARDLS014	187308	F.33
P9ACGP4L	187826		P9ACPBS246	188246	F.36	P9ARB6R	187421	F.32	P9ARDLS017	187309	F.33
P9ACGP4R	187821		P9ACPBS250	188250	F.36	P9ARB6V	187422	F.32	P9ARDLS018	187310	F.33
P9ACGP4V	187822		P9ACPBS255	188255	F.36	P9ARB6B	187107	F.32	P9ARDLS024	187973	F.33
P9ACGSLA	187835		P9ACPBS256	188256	F.36	P9ARBG006	187152	F.32	P9ARDLS026	187311	F.33
P9ACGSLB	187837		P9ACPBS258	188258	F.36	P9ARBG026	188056	F.32	P9ARDLS027	187312	F.33
P9ACGSLG	187833		P9ACPBS269	188269	F.36	P9ARBG028	187151	F.32	P9ARDLS028	187302	F.33
P9ACGSLI	187838		P9ACPBS291	188291	F.36	P9ARBG030	188057	F.32	P9ARDLS029	187301	F.33
P9ACGSLL	187836		P9ACPBS301	188301	F.36	P9ARBG097	188058	F.32	P9ARDLS030	187318	F.33
P9ACGSLR	187831		P9ACPBS302	188302	F.36	P9ARBG202	188909	F.32	P9ARDLS031	187313	F.33
P9ACGSLV	187832		P9ACPBS303	188303	F.36	P9ARBG	187103	F.32	P9ARDLS032	187314	F.33
P9ACKITI	188099		P9ACPBS304	188304	F.36	P9ARBG099	187099	F.32	P9ARDLS035	187303	F.33
P9ACKITU	188098		P9ACPBS305	188305	F.36	P9ARBGH	187108	F.32	P9ARDLS038	187304	F.33
P9ACMNG	187813		P9ACPBS306	188306	F.36	P9ARBGL	187106	F.32	P9ARDLS201	187319	F.33
P9ACMNL	187816		P9ACPBS307	188307	F.36	P9ARBGL037	187143	F.32	P9ARDLS202	187320	F.33
P9ACMNN	187810		P9ACPBS308	188308	F.36	P9ARBM	187104	F.32	P9ARDPL	187350	F.33
P9ACMNR	187811		P9ACPBS309	188309	F.36	P9ARBMN	187100	F.32	P9ARDPL001	187365	F.33
P9ACMNV	187812		P9ACPBS316	188316	F.36	P9ARBG001	187137	F.32	P9ARDPL002	187366	F.33
P9ACPANI	188088		P9ACPBS317	188317	F.36	P9ARBG002	187139	F.32	P9ARDPL005	187367	F.33
P9ACPBS	188015		P9ACPBS320	188320	F.36	P9ARBG005	187141	F.32	P9ARDPL006	187355	F.33
P9ACPBS039	188030	F.36	P9ACPBS321	188321	F.36	P9ARBG006	187117	F.32	P9ARDPL012	187356	F.33
P9ACPBS042	188033	F.36	P9ACPBS323	188323	F.36	P9ARBG012	187119	F.32	P9ARDPL013	187357	F.33
P9ACPBS101	188101	F.36	P9ACPBS324	188324	F.36	P9ARBG013	187121	F.32	P9ARDPL014	187358	F.33
P9ACPBS102	188102	F.36	P9ACPBS326	188326	F.36	P9ARBG014	187123	F.32	P9ARDPL017	187359	F.33
P9ACPBS103	188103	F.36	P9ACPBS328	188328	F.36	P9ARBG017	187125	F.32	P9ARDPL018	187360	F.33
P9ACPBS104	188104	F.36	P9ACPBS334	188334	F.36	P9ARBG018	187127	F.32	P9ARDPL026	187361	F.33
P9ACPBS105	188105	F.36	P9ACPBS337	188337	F.36	P9ARBG026	187129	F.32	P9ARDPL027	187362	F.33
P9ACPBS106	188106	F.36	P9ACPBS405	188405	F.36	P9ARBG027	187131	F.32	P9ARDPL028	187352	F.33
P9ACPBS107	188107	F.36	P9ACPBS406	188406	F.36	P9ARBG028	187111	F.32	P9ARDPL029	187351	F.33
P9ACPBS108	188108	F.36	P9ACPBS510	188510	F.36	P9ARBG029	187150	F.32	P9ARDPL030	187368	F.33



Controls Alphabetical Index

Cat. no.	Ref. no	Cat. pg	Cat. no.	Ref. no	Cat. pg	Cat. no.	Ref. no	Cat. pg	Cat. no.	Ref. no	Cat. pg
P9ARDPL031	187363	F.33	P9ARTAPN905	116157	F.36	P9ASGP3L	187776		P9CMN2A	190702	F.23
P9ARDPL032	187364	F.33	P9ARTAPN906	116158	F.36	P9ASGP3V	187772		P9CMN2B	190703	F.23
P9ARDPL035	187353	F.33	P9ARTBM	188001		P9ASGPDA	187945		P9CMN2F	190700	F.23
P9ARDPL038	187354	F.33	P9ARTBS	188000		P9ASGPDG	187947		P9CMN2T	190701	F.23
P9ARDPL041	188996	F.33	P9ARTBS039	116100		P9ASGPDGB	187943		P9CMN4C	190722	F.23
P9ARDPL042	188997	F.33	P9ARTBS040	116160		P9ASGPDJ	187948		P9CMN4F	190720	F.23
P9ARDPL096	187255	F.33	P9ARTBS042	116477		P9ASGPDJL	187946		P9CMN4T	190721	F.23
P9ARDPL098	188999	F.33	P9ARTBS155	116478		P9ASGPDPR	187941		P9CPCN1E95	190103	
P9ARDPL201	187369	F.33	P9ARTBS502	116479		P9ASGPDV	187942		P9CPCN1K95	190100	
P9ARDPL202	187370	F.33	P9ARTBS508	116480		P9ASHAC	187794		P9CPCN2E95	190104	
P9ARGLDA	187435		P9ARTBS510	116481		P9ASHP3	187792		P9CPCN2K95	190101	
P9ARGLDB	187437		P9ARTBS511	116482		P9ASHP5	187793		P9CPCN3E95	190105	
P9ARGLDG	187433		P9ARTBS515	116162		P9ASSRPL	188009		P9CPCN3K01	193545	
P9ARGLDI	187438		P9ARTBS517	116484		P9ASTBS	188010		P9CPCN3K95	190102	
P9ARGLDL	187436		P9ARTBS522	133890		P9ASTTS	188014		P9CPTL0E0	190519	F.20
P9ARGLDR	187431		P9ARTBS909	116840		P9ASTWS	188011		P9CPL0G0	190499	F.20
P9ARGLDV	187432		P9ARTBS910	116841		P9B01BN	187017	F.26	P9CPL0S0	190509	F.20
P9ARGLRA	187445		P9ARTTM	188013		P9B01FH	187014	F.24	P9CPLAGD	190495	F.20
P9ARGLRB	187447		P9ARTTS	188012		P9B01FN	187012	F.24	P9CPLASD	190505	F.20
P9ARGLRG	187443		P9ARTWM	188008		P9B01VN	187001	F.24	P9CPLBGD	190497	F.20
P9ARGLRI	187448		P9ARTWS	188005		P9B01VR	187003	F.24	P9CPLBSD	190507	F.20
P9ARGLRL	187446		P9ASB3G	187753		P9B02VN	187008	F.24	P9CPLGGD	190493	F.20
P9ARGLRR	187441		P9ASB3N	187750		P9B10BN	187018	F.26	P9CPLGSD	190503	F.20
P9ARGLRV	187442		P9ASB3V	187752		P9B10FH	187015	F.24	P9CPLIGD	190498	F.20
P9ARGLVA	187455		P9ASBGB	187507		P9B10FN	187013	F.24	P9CPLISD	190508	F.20
P9ARGLVB	187457		P9ASBGB028	187551		P9B10VA	187004	F.24	P9CPLLLD	190496	F.20
P9ARGLVG	187453		P9ASBGG	187503		P9B10VN	187002	F.24	P9CPLLSD	190506	F.20
P9ARGLVI	187458		P9ASBGL	187506		P9B11VN	187006	F.24	P9CPLRGD	190491	F.20
P9ARGLVR	187451		P9ASBGL037	187543		P9B20VN	187009	F.24	P9CPLRSD	190501	F.20
P9ARGLVW	187452		P9ASBGN	187500		P9CBB	190696		P9CPLVGD	190492	F.20
P9ARGP4A	187485		P9ASBGN001	187537		P9CCC	190697		P9CPLVSD	190502	F.20
P9ARGP4B	187487		P9ASBGN006	187517		P9CCD	190695	F.21	P9CPLN0E	190029	F.13
P9ARGP4G	187483		P9ASBGN012	187519		P9CFCARN37	193512		P9CPLN0G	190009	F.13
P9ARGP4I	187488		P9ASBGN013	187521		P9CFCARN95	190073		P9CPLN0S	190019	F.13
P9ARGP4L	187486		P9ASBGN017	187525		P9CEM3GN	190033	F.13	P9CPLN8G	190007	F.13
P9ARGP4R	187481		P9ASBGN018	187527		P9CEM3RN	190031	F.13	P9CPLNBS	190017	F.13
P9ARGP4V	187482		P9ASBGN026	187529		P9CEM4GL	190553	F.13	P9CPLNGG	190003	F.13
P9ARGPDA	187465		P9ASBGN027	187531		P9CEM4GN	190043	F.13	P9CPLNGS	190013	F.13
P9ARGPDB	187467		P9ASBGN028	187511		P9CEM4NN	190040	F.13	P9CPLNLG	190006	F.13
P9ARGPDG	187463		P9ASBGN029	187550		P9CEM4RL	190551	F.13	P9CPLNLS	190016	F.13
P9ARGPDI	187468		P9ASBGN030	187545		P9CEM4RN	190041	F.13	P9CPLNMS	190014	F.13
P9ARGPDL	187466		P9ASBGN038	187515		P9CEM4VL	190552	F.13	P9CPLPNN	190000	F.13
P9ARGPDR	187461		P9ASBGN202	187548		P9CEM4VN	190042	F.13	P9CPLPNS	190010	F.13
P9ARGPDU	242634		P9ASBGR	187501		P9CEM6RN	190051	F.13	P9CPLNRG	190001	F.13
P9ARGPDV	187462		P9ASBGR029	187510		P9CEM6VN	190052	F.13	P9CPLNRS	190011	F.13
P9ARGSAR	187471		P9ASBGR036	187544		P9CER3RN	190070	F.13	P9CPLNVE	190022	F.13
P9ARGSAV	187472		P9ASBGR201	187547		P9CER4RN	190071	F.13	P9CPLPNV	190002	F.13
P9ARHPR	187491	F.34	P9ASBGV	187502		P9CET00L1	190569		P9CPLPVS	190012	F.13
P9ARMVG	188813		P9ASBGV002	187540		P9CET00L2	190579		P9CPS21G	190690	F.21
P9ARMVL	188816		P9ASBGV006	187518		P9CET00L3	190570		P9CPS22G	190691	F.21
P9ARMVN	187430		P9ASBGV012	187520		P9CET4AL1	190565		P9CPS23G	190692	F.21
P9ARMVR	188811		P9ASBGV013	187522		P9CET4AL2	190575		P9CPS34G	190693	F.21
P9ARMVV	188812		P9ASBGV017	187526		P9CET4AL3	190585		P9CPS35G	190694	F.21
P9ARPB	188002	F.36	P9ASBGV018	187528		P9CET4BL1	190567		P9CRG	190771	F.22
P9ARPTM	188019	F.36	P9ASBGV026	187530		P9CET4BL2	190577		P9CSCDOA95	190400	F.18
P9ARPWM	188028	F.36	P9ASBGV028	187512		P9CET4GL1	190563		P9CSCDOE95	190401	F.18
P9ARRE4	187492		P9ASBGV030	187546		P9CET4GL2	190573		P9CSCDOK95	190402	F.18
P9ARSCMB	188044	F.23	P9ASBGV035	187514		P9CET4GL3	190583		P9CSCDSA95	190409	F.18
P9ARSCMN	188043	F.23	P9ASBGV202	187549		P9CET4GN1	190063	F.13	P9CSCEOC95	190413	F.18
P9ARSG01	187493		P9ASBSB	187607		P9CET4LL1	190566		P9CSCEOI95	190418	F.18
P9ARSG02	187494		P9ASBSG	187603		P9CET4LL2	190576		P9CSCENI95	190442	F.19
P9ARSGMB	187496	F.23	P9ASBSH	187608		P9CET4LL3	190586		P9CSCESC95	190464	F.19
P9ARSN1	188805		P9ASBSL	187606		P9CET4NN1	190060	F.13	P9CSCESH95	190454	F.19
P9ARSRPL	188055	F.33	P9ASBSM	187604		P9CET4NN2	190080	F.13	P9CSCHIC95	190411	F.18
P9ARSSMN	187495	F.23	P9ASBSN	187600		P9CET4NN3	190090	F.13	P9CSCIC95	190403	F.18
P9ARTAPN	116099	F.36	P9ASBSN006	187617		P9CET4RL1	190561		P9CSCION95	190405	F.18
P9ARTAPN006	134244	F.36	P9ASBSN028	187611		P9CET4RL2	190571		P9CSCISC95	190410	F.18
P9ARTAPN028	118846	F.36	P9ASBSN030	187645		P9CET4RL3	190581		P9CSCXOA95	190468	F.19
P9ARTAPN039	116140	F.36	P9ASBSN202	187648		P9CET4RN1	190061	F.13	P9CSCXOB95	190469	F.19
P9ARTAPN040	116991	F.36	P9ASBSR	187601		P9CET4RN2	190081	F.13	P9CSCXOZ95	190482	F.19
P9ARTAPN042	116141	F.36	P9ASBSR029	187610		P9CET4RN3	190091	F.13	P9CSCZOA95	190433	F.18
P9ARTAPN155	116142	F.36	P9ASBSR201	187647		P9CET4VL1	190562		P9CSCZOC95	190434	F.18
P9ARTAPN201	116143	F.36	P9ASBSV	187602		P9CET4VL2	190572		P9CSCZOE95	190435	F.18
P9ARTAPN202	116144	F.36	P9ASBSV006	187618		P9CET4VL3	190582		P9CSCZOK95	190437	F.18
P9ARTAPN206	116145	F.36	P9ASBSV028	187612		P9CET4VN1	190062	F.13	P9CSCZOT95	190439	F.18
P9ARTAPN211	116146	F.36	P9ASBSV030	187646		P9CET4VN2	190082	F.13	P9CSCZIC95	190449	F.19
P9ARTAPN212	116147	F.36	P9ASBSV202	187649		P9CET4VN3	190092	F.13	P9CSCZIN95	190451	F.19
P9ARTAPN213	116148	F.36	P9ASCGG	187783		P9CLO0	190799		P9CSCZJC38	194623	F.19
P9ARTAPN268	116149	F.36	P9ASCGN	187780		P9CLAD	190795	F.14	P9CSCZJC95	190467	F.19
P9ARTAPN291	116150	F.36	P9ASCGR	187781		P9CLAR	190805	F.14	P9CSCZSA95	190461	F.19
P9ARTAPN501	188081	F.36	P9ASCGT	187790		P9CLBD	190797	F.14	P9CSCZSC95	190462	F.19
P9ARTAPN505	116163	F.36	P9ASCGV	187782		P9CLBR	190807	F.14	P9CSCZSH95	190463	F.19
P9ARTAPN506	188082	F.36	P9ASCST	187791	F.21	P9CLGD	190793	F.14	P9CSLD00	190599	F.20
P9ARTAPN507	188083	F.36	P9ASDPL	215339		P9CLID	190798	F.14	P9CSLDOA	190595	F.20
P9ARTAPN510	116151	F.36	P9ASEBG	187795		P9CLLD	190796	F.14	P9CSLD0B	190597	F.20
P9ARTAPN511	116152	F.36	P9ASGLDA	187765		P9CLLR	190806	F.14	P9CSLD0G	190593	F.20
P9ARTAPN515	116153	F.36	P9ASGLDG	187763		P9CLRD	190791	F.14	P9CSLD0I	190598	F.20
P9ARTAPN516	116854	F.36	P9ASGLDI	187768		P9CLRR	190801	F.14	P9CSLD0L	190596	F.20
P9ARTAPN517	116154	F.36	P9ASGLDL	187766		P9CLVD	190792	F.14	P9CSLD0R	190591	F.20
P9ARTAPN522	116155	F.36	P9ASGLDR	187761		P9CLVR	190802	F.14	P9CSLD0V	190592	F.20
P9ARTAPN523	188084	F.36	P9ASGLDV	187762		P9CMB2B	190713	F.23	P9CSLZ00	190609	F.20
P9ARTAPN524	188079	F.36	P9ASGP3A	187775		P9CMB2F	190710	F.23	P9CSLZ0A	190605	F.20
P9ARTAPN525	188080	F.36	P9ASGP3B	187777		P9CMB2T	190711	F.23	P9CSLZ0B	190607	F.20
P9ARTAPN532	116992	F.36	P9ASGP3G	187773		P9CMB4F	190740	F.23	P9CSLZ0G	190603	F.20
P9ARTAPN904	116156	F.36	P9ASGPF3I	187778		P9CMB4T	190741	F.23	P9CSLZ0I	190608	F.20

Intro

A

B

C

D

E

F

G

H

I

X



Controls Alphabetical Index

Cat. no.	Ref. no	Cat. pg	Cat. no.	Ref. no	Cat. pg	Cat. no.	Ref. no	Cat. pg	Cat. no.	Ref. no	Cat. pg
P9CSL20L	190606	F.20	P9PE04	189004	F.28	P9MLR	184808	F.14	P9MPNGG	184003	F.13
P9CSL20R	190601	F.20	P9PE06	189005	F.28	P9MLRV	184818	F.14	P9MPNGS	184057	F.13
P9CSL20V	190602	F.20	P9PEEG1	189000	F.28	P9MLLD	184796	F.14	P9MPNHG	184028	F.13
P9CSL21L	190616	F.20	P9PEEM	189200	F.28	P9MLLR	184806	F.14	P9MPNHG	184008	F.13
P9CSL230	190639	F.20	P9PELO2X01	189136	F.30	P9MLLV	184816	F.14	P9MPNLE	184026	F.13
P9CSL23G	190633	F.20	P9PELO2X03	189143	F.30	P9MLRD	184791	F.14	P9MPNLG	184006	F.13
P9CSL23R	190631	F.20	P9PELO3X02	189139	F.30	P9MLRR	184801	F.14	P9MPNLS	184016	F.13
P9CSL23V	190632	F.20	P9PELO4X01	189141	F.30	P9MLRV	184811	F.14	P9MPNME	184024	F.13
P9CSL25V	190622	F.20	P9PMB	184866	F.21	P9MLVD	184792	F.14	P9MPNMG	184004	F.13
P9CSMD00	190119	F.16	P9PMCC	184697	F.21	P9MLVR	184802	F.14	P9MPNNE	184020	F.13
P9CSMD0N	190110	F.16	P9PMCD	184695	F.21	P9MLVW	184812	F.14	P9MPNNG	184000	F.13
P9CSMD5N	190140	F.16	P9MEC4RN01	192000		P9MMB2A	184712	F.23	P9MPNNS	184010	F.13
P9CSME00	190179	F.16	P9MEC4RN02	192001		P9MMB2B	184713	F.23	P9MPNRE	184021	F.13
P9CSMH1N	190160	F.16	P9MEC4RN03	192002		P9MMB2F	184710	F.23	P9MPNRG	184001	F.13
P9CSMI00	190129	F.16	P9MEC4RN04	192003		P9MMB2FG	184709	F.23	P9MPNRS	184011	F.13
P9CSMI0N	190120	F.16	P9MEC4RN05	192004		P9MMB2T	184711	F.23	P9MPNVE	184022	F.13
P9CSMI5N	190150	F.16	P9MEC4RN10	192005		P9MMB4F	184740	F.23	P9MPNVG	184002	F.13
P9CSMI5V	190152	F.16	P9MEC4RN16	192006		P9MMB4T	184741	F.23	P9MPNVS	184012	F.13
P9CSMU00	190199	F.16	P9MEC4RN19	192007		P9MMB4TG	184744	F.23	P9MPS21G	184690	F.21
P9CSMU0N	190190	F.16	P9MEC4RN33	192010		P9MMN2A	184702	F.23	P9MPS22G	184691	F.21
P9CSMU3N	190310	F.16	P9MEC4RN34	192011		P9MMN2B	184703	F.23	P9MPS23G	184692	F.21
P9CSMU50	190279	F.16	P9MEC4RN37	192012		P9MMN2F	184700	F.23	P9MPS34G	184693	F.21
P9CSMU5N	190270	F.16	P9MEC4RN38	192013		P9MMN2FG	184718	F.23	P9MPS35G	184694	F.21
P9CSMW0N	190360	F.16	P9MEC4RN40	192014		P9MMN2T	184701	F.23	P9MPS36K	184698	F.21
P9CSMX00	190339	F.16	P9MEC4RN95	184073		P9MMN4C	184722	F.23	P9MPS37K	184689	F.21
P9CSMX0N	190330	F.16	P9MEC53130	153130		P9MMN4F	184720	F.23	P9MRG	184771	F.22
P9CSMX5N	190340	F.16	P9MEM3GN	184033	F.13	P9MMN4H	184724	F.23	P9MSA0A	184645	F.20
P9CSMY00	190359	F.16	P9MEM3LN	184036	F.13	P9MMN4T	184721	F.23	P9MSA0B	184647	F.20
P9CSMY0N	190350	F.16	P9MEM3NN	184030	F.13	P9MMN4TG	184716	F.23	P9MSA0G	184643	F.20
P9CSMZ00	190209	F.16	P9MEM3RN	184031	F.13	P9MPCN1E34	192071		P9MSA0I	184648	F.20
P9CSMZ0N	190200	F.16	P9MEM3VN	184032	F.13	P9MPCN1E40	192074		P9MSA0L	184646	F.20
P9CSMZ0R	190201	F.16	P9MEM4BL	184557	F.13	P9MPCN1E95	184103		P9MSA0R	184641	F.20
P9CSMZ1N	190240	F.16	P9MEM4GL	184553	F.13	P9MPCN1K34	192026		P9MSA0V	184642	F.20
P9CSMZ30	190329	F.16	P9MEM4GN	184043	F.13	P9MPCN1K37	192027		P9MSA20A	184655	F.20
P9CSMZ3G	190323	F.16	P9MEM4IL	184558	F.13	P9MPCN1K95	184100		P9MSA20B	184657	F.20
P9CSMZ3N	190320	F.16	P9MEM4LL	184556	F.13	P9MPCN2E01	192075		P9MSA20G	184653	F.20
P9CSMZ3V	190322	F.16	P9MEM4LN	184046	F.13	P9MPCN2E02	192076		P9MSA20I	184658	F.20
P9CSMZ5N	190280	F.16	P9MEM4NN	184040	F.13	P9MPCN2E03	192077		P9MSA20L	184656	F.20
P9CSV00N	190370	F.17	P9MEM4RL	184551	F.13	P9MPCN2E05	192079		P9MSA20R	184651	F.20
P9CSVE0N	190376	F.17	P9MEM4RN	184041	F.13	P9MPCN2E10	192080		P9MSA20V	184652	F.20
P9CSVE3N	190388	F.17	P9MEM4VL	184552	F.13	P9MPCN2E16	192081		P9MSA21B	184667	F.20
P9CSVH1N	190375	F.17	P9MEM4VN	184042	F.13	P9MPCN2E95	184104		P9MSA21G	184663	F.20
P9CSVION	190371	F.17	P9MEM53111	153111	F.13	P9MPCN2K95	184101		P9MSA21I	184668	F.20
P9CSV15N	190374	F.17	P9MEM53112	153112	F.13	P9MPCN3E95	184105		P9MSA21L	184666	F.20
P9CSVU0N	190378	F.17	P9MEM6GN	184053	F.13	P9MPCN3K95	184102		P9MSA21R	184661	F.20
P9CSVU3N	190390	F.17	P9MEM6NN	184050	F.13	P9MPL0E0	184519	F.20	P9MSA21V	184662	F.20
P9CSVW0N	190395	F.17	P9MEM6RN	184051	F.13	P9MPL0G0	184499	F.20	P9MSA23A	184685	F.20
P9CSVX0N	190392	F.17	P9MEM6VN	184052	F.13	P9MPL0S0	184509	F.20	P9MSA23B	184687	F.20
P9CSVX5N	190393	F.17	P9MER3RN	184070	F.13	P9MPL53511	153511	F.20	P9MSA23G	184683	F.20
P9CSVY0N	190394	F.17	P9MER4RN	184071	F.13	P9MPL53513	153513	F.20	P9MSA23I	184688	F.20
P9CSVZ0N	190379	F.17	P9MERS3161	153161	F.13	P9MPL53514	153514	F.20	P9MSA23L	184686	F.20
P9CSVZ1N	190383	F.17	P9MET4AL1	184565		P9MPL53515	153515	F.20	P9MSA23R	184681	F.20
P9CSVZ3N	190391	F.17	P9MET4AL3	184585		P9MPL53530	153530	F.20	P9MSA23V	184682	F.20
P9CSVZ5N	190387	F.17	P9MET4BL1	184567		P9MPL53531	153531	F.20	P9MSA25B	184677	F.20
P9CWR	190770	F.22	P9MET4BL2	184577		P9MPL53561	153561	F.20	P9MSA25G	184673	F.20
P9CZ	190772	F.22	P9MET4GL1	184563		P9MPLAED	184515	F.20	P9MSA25I	184678	F.20
P9DPL54700	154700	F.20	P9MET4GL2	184573		P9MPLAGD	184495	F.20	P9MSA25R	184671	F.20
P9DPL54701	154701	F.20	P9MET4GL3	184583		P9MPLASD	184505	F.20	P9MSA25V	184672	F.20
P9DPL54720	154720	F.20	P9MET4GN1	184063	F.13	P9MPLBED	184517	F.20	P9MSC53435	153435	
P9DPL54721	154721	F.20	P9MET4IL1	184568		P9MPLBGD	184497	F.20	P9MSC53436	153436	
P9DPLBNG01	186896	F.20	P9MET4LL1	184566		P9MPLBGV	184527	F.20	P9MSC53498	153498	
P9DPLNB501	186898	F.20	P9MET4LL2	184576		P9MPLBSD	184507	F.20	P9MSCD0A01	192105	F.18
P9DPLNNG00	186885	F.20	P9MET4LL3	184586		P9MPLGED	184513	F.20	P9MSCD0A02	192106	F.18
P9DPLNNG04	186897	F.20	P9MET4LN1	184066	F.13	P9MPLGGD	184493	F.20	P9MSCD0A03	192107	F.18
P9DPLNRG00	186880	F.20	P9MET4NN1	184060	F.13	P9MPLGGV	184523	F.20	P9MSCD0A04	192108	F.18
P9DPLNRG01	186890	F.20	P9MET4RL1	184561		P9MPLGSD	184503	F.20	P9MSCD0A05	192109	F.18
P9DPLNR500	186882	F.20	P9MET4RL2	184571		P9MPLIED	184518	F.20	P9MSCD0A10	192110	F.18
P9DPLNR501	186892	F.20	P9MET4RL3	184581		P9MPLIGD	184498	F.20	P9MSCD0A16	192111	F.18
P9DPLVRG00	186881	F.20	P9MET4RN1	184061	F.13	P9MPLISD	184508	F.20	P9MSCD0A19	192112	F.18
P9DPLVRG01	186891	F.20	P9MET4RN2	184081	F.13	P9MPLLED	184516	F.20	P9MSCD0A33	192115	F.18
P9DPLVRGT01	186895	F.20	P9MET4RN3	184091	F.13	P9MPLLLD	184496	F.20	P9MSCD0A37	192116	F.18
P9DPLVRS00	186883	F.20	P9MET4VL1	184562		P9MPLLVG	184526	F.20	P9MSCD0A38	192117	F.18
P9DPLVRS01	186893	F.20	P9MET4VL3	184582		P9MPLLSD	184506	F.20	P9MSCD0A38	192118	F.18
P9EPA01Y02	189010	F.29	P9MET4VN1	184062	F.13	P9MPLRED	184511	F.20	P9MSCD0A40	192119	F.18
P9EPA01Y03	189011	F.29	P9MET4VN2	184082	F.13	P9MPLRGD	184491	F.20	P9MSCD0A53	192113	F.18
P9EPA02Y01	189016	F.29	P9MET53121	153121		P9MPLRGR	184521	F.20	P9MSCD0A95	184400	F.18
P9EPA03Y01	189018	F.29	P9ML00	184799		P9MPLRSD	184501	F.20	P9MSCD0E01	192120	F.18
P9EPA03Y03	189020		P9MLAD	184795	F.14	P9MPLVED	184512	F.20	P9MSCD0E02	192121	F.18
P9EPA03Y05	189022	F.29	P9MLAR	184805	F.14	P9MPLVGD	184492	F.20	P9MSCD0E03	192122	F.18
P9EPA06Y01	189023		P9MLAV	184815	F.14	P9MPLVGV	184522	F.20	P9MSCD0E04	192123	F.18
P9EPAG1Y01N	189007	F.29	P9MLBD	184797	F.14	P9MPLVSD	184502	F.20	P9MSCD0E05	192124	F.18
P9EPAG1Y01W	189008	F.29	P9MLBR	184807	F.14	P9MPNOE	184029	F.13	P9MSCD0E10	192125	F.18
P9EPAG1Y02	189144		P9MLBV	184817	F.14	P9MPNOG	184009	F.13	P9MSCD0E33	192130	F.18
P9EPAG1Y06N	189009		P9MLD53610	153610		P9MPN0S	184019	F.13	P9MSCD0E34	192131	F.18
P9EPAG1Y08	189025		P9MLD53611	153611		P9MPNS3006	153006	F.13	P9MSCD0E37	192132	F.18
P9EPC01X00	215432	F.29	P9MLD53612	153612		P9MPNS3007	153007	F.13	P9MSCD0E38	192133	F.18
P9EPC01X01	215433	F.29	P9MLD53613	153613		P9MPNS3008	153008	F.13	P9MSCD0E95	184401	F.18
P9EPC02Y01	242446		P9MLD53614	153614		P9MPNS3009	153009	F.13	P9MSCD0K01	192135	F.18
P9EPC04X00	242709		P9MLD53620	153623		P9MPNS3010	153010	F.13	P9MSCD0K02	192136	F.18
P9EPC06X00	242234		P9MLD53621	153621		P9MPNS3011	153011	F.13	P9MSCD0K03	192137	F.18
P9EPC06X02	242629		P9MLD53622	153622		P9MPNS3061	153061	F.13	P9MSCD0K04	192138	F.18
P9EPCG1X02	242704		P9MLGD	184793	F.14	P9MPNBE	184027	F.13	P9MSCD0K05	192139	F.18
P9PEE01	189001	F.28	P9MLGR	184803	F.14	P9MPNBG	184007	F.13	P9MSCD0K10	192140	F.18
P9PEE02	189002	F.28	P9MLGV	184813	F.14	P9MPNBS	184017	F.13	P9MSCD0K16	192141	F.18
P9PEE03	189003	F.28	P9MLID	184798	F.14	P9MPNGE	184023	F.13	P9MSCD0K19	192142	F.18



Controls Alphabetical Index

Cat. no.	Ref. no	Cat. pg	Cat. no.	Ref. no	Cat. pg	Cat. no.	Ref. no	Cat. pg	Cat. no.	Ref. no	Cat. pg
P9MSCD0K33	192145	F.18	P9MSCION38	192193	F.18	P9MSCZ20T2	192691	F.18	P9MSMD5G	184143	F.16
P9MSCD0K34	192146	F.18	P9MSCION95	184405	F.18	P9MSCZ20T3	192692	F.18	P9MSMD5N	184140	F.16
P9MSCD0K37	192147	F.18	P9MSCI5C01	192255	F.18	P9MSCZ20T4	192693	F.18	P9MSMD5R	184141	F.16
P9MSCD0K38	192148	F.18	P9MSCI5C03	192257	F.18	P9MSCZ20T5	192694	F.18	P9MSMD5V	184142	F.16
P9MSCD0K40	192149	F.18	P9MSCI5C04	192258	F.18	P9MSCZ20T10	192695	F.18	P9MSME0L	184176	F.16
P9MSCD0K53	192143	F.18	P9MSCI5C05	192259	F.18	P9MSCZ20T16	192696	F.18	P9MSME0N	184170	F.16
P9MSCD0K95	184402	F.18	P9MSCI5C10	192260	F.18	P9MSCZ20T33	192700	F.18	P9MSME0R	184171	F.16
P9MSCD5A01	192240	F.18	P9MSCI5C19	192262	F.18	P9MSCZ20T34	192701	F.18	P9MSME0V	184172	F.16
P9MSCD5A02	192241	F.18	P9MSCI5C33	192265	F.18	P9MSCZ20T37	192702	F.18	P9MSME1L	184216	F.16
P9MSCD5A03	192242	F.18	P9MSCI5C34	192266	F.18	P9MSCZ20T38	192703	F.18	P9MSME1N	184210	F.16
P9MSCD5A04	192243	F.18	P9MSCI5C37	192267	F.18	P9MSCZ20T40	192704	F.18	P9MSME1R	184211	F.16
P9MSCD5A05	192244	F.18	P9MSCI5C38	192268	F.18	P9MSCZ20T95	184439	F.18	P9MSME1V	184212	F.16
P9MSCD5A33	192250	F.18	P9MSCI5C40	192269	F.18	P9MSCZ1C01	192840	F.18	P9MSME3G	184293	F.16
P9MSCD5A34	192251	F.18	P9MSCI5C53	192263	F.18	P9MSCZ1C95	184449	F.18	P9MSME3L	184296	F.16
P9MSCD5A37	192252	F.18	P9MSCI5C95	184410	F.18	P9MSCZ1E95	184450	F.18	P9MSME3N	184290	F.16
P9MSCD5A38	192253	F.18	P9MSCLOA95	184419	F.18	P9MSCZ1N01	192870	F.18	P9MSME3R	184291	F.16
P9MSCD5A40	192254	F.18	P9MSCLOC95	184420	F.18	P9MSCZ21N38	192883	F.18	P9MSME3V	184292	F.16
P9MSCD5A95	184409	F.18	P9MSCLOK01	192450	F.18	P9MSCZ21N95	184451	F.18	P9MSME5G	184253	F.16
P9MSCEOA01	192285	F.18	P9MSCLOK02	192451	F.18	P9MSCZ3C01	193110	F.19	P9MSME5N	184396	F.16
P9MSCEOA02	192286	F.18	P9MSCLOK03	192452	F.18	P9MSCZ3C02	193111	F.19	P9MSMH0N	184130	F.16
P9MSCEOA38	192298	F.18	P9MSCLOK04	192453	F.18	P9MSCZ3C03	193112	F.19	P9MSMH0R	184131	F.16
P9MSCEOA95	184412	F.18	P9MSCLOT95	184425	F.18	P9MSCZ3C04	193113	F.19	P9MSMH0V	184132	F.16
P9MSCEOC01	192300	F.18	P9MSCLIN95	184445	F.19	P9MSCZ3C05	193114	F.19	P9MSMH1N	184160	F.16
P9MSCEOC05	192304	F.18	P9MSCU0A95	184426	F.18	P9MSCZ3C10	193115	F.19	P9MSMH1R	184161	F.16
P9MSCEOC40	192314	F.18	P9MSCU0C34	192521	F.18	P9MSCZ3C16	193116	F.19	P9MSMH1V	184162	F.16
P9MSCEOC95	184413	F.18	P9MSCU0C95	184427	F.18	P9MSCZ3C19	193117	F.19	P9MSMI0G	184123	F.16
P9MSCEOE01	192315	F.18	P9MSCU0E95	184428	F.18	P9MSCZ3C34	193121	F.19	P9MSMI0L	184126	F.16
P9MSCEOE95	184414	F.18	P9MSCU0H95	184429	F.18	P9MSCZ3C38	193123	F.19	P9MSMI0N	184120	F.16
P9MSCEOH01	192330	F.18	P9MSCU0K95	184430	F.18	P9MSCZ3C95	184467	F.19	P9MSMI0R	184121	F.16
P9MSCEOH02	192331	F.18	P9MSCU0N95	184431	F.18	P9MSCZ5A01	193020	F.19	P9MSMI0V	184122	F.16
P9MSCEOH03	192332	F.18	P9MSCU0T33	192595	F.18	P9MSCZ5A02	193021	F.19	P9MSMI5G	184153	F.16
P9MSCEOH04	192333	F.18	P9MSCU0T34	192596	F.18	P9MSCZ5A03	193022	F.19	P9MSMI5N	184150	F.16
P9MSCEOH05	192334	F.18	P9MSCU0T37	192597	F.18	P9MSCZ5A04	193023	F.19	P9MSMI5R	184151	F.16
P9MSCEOH10	192335	F.18	P9MSCU0T38	192598	F.18	P9MSCZ5A05	193024	F.19	P9MSMI5V	184152	F.16
P9MSCEOH16	192336	F.18	P9MSCU0T95	184432	F.18	P9MSCZ5A10	193025	F.19	P9MSMI0G	184183	F.16
P9MSCEOH19	192337	F.18	P9MSCU1E95	184447	F.19	P9MSCZ5A16	193026	F.19	P9MSMI0N	184180	F.16
P9MSCEOH33	192340	F.18	P9MSCU1N01	192825	F.19	P9MSCZ5A19	193027	F.19	P9MSMI0R	184181	F.16
P9MSCEOH34	192341	F.18	P9MSCU1N95	184448	F.19	P9MSCZ5A33	193030	F.19	P9MSMI0V	184182	F.16
P9MSCEOH37	192342	F.18	P9MSCU3C01	193095	F.19	P9MSCZ5A37	193032	F.19	P9MSML1G	184223	F.16
P9MSCEOH38	192343	F.18	P9MSCU3C95	184466	F.19	P9MSCZ5A53	193028	F.19	P9MSML1N	184220	F.16
P9MSCEOH40	192344	F.18	P9MSCU5A95	184467	F.19	P9MSCZ5A95	184461	F.19	P9MSML1V	184222	F.16
P9MSCEOH53	192338	F.18	P9MSCU5C95	184459	F.19	P9MSCZ5C02	193036	F.19	P9MSML3N	184300	F.16
P9MSCEOH95	184415	F.18	P9MSCU5H02	193009	F.19	P9MSCZ5C34	193046	F.19	P9MSML3R	184301	F.16
P9MSCE0K95	184416	F.18	P9MSCU5H95	184460	F.19	P9MSCZ5C95	184462	F.19	P9MSML5N	184260	F.16
P9MSCE0N95	184417	F.18	P9MSCX0A01	193125	F.19	P9MSCZ5H01	193050	F.19	P9MSMU0L	184199	F.16
P9MSCE0T01	192375	F.18	P9MSCX0A38	193138	F.19	P9MSCZ5H02	193054	F.19	P9MSMU00	184196	F.16
P9MSCE0T02	192376	F.18	P9MSCX0A95	184468	F.19	P9MSCZ5H95	184463	F.19	P9MSMU0R	184190	F.16
P9MSCE0T34	192386	F.18	P9MSCX0B33	193150	F.19	P9MSLD00	184599	F.20	P9MSMU0N	184191	F.16
P9MSCE0T38	192388	F.18	P9MSCX0B95	184469	F.19	P9MSLD0A	184595	F.20	P9MSMU0V	184192	F.16
P9MSCE0T95	184418	F.18	P9MSCX0D95	184470	F.19	P9MSLD0B	184597	F.20	P9MSMU1L	184236	F.16
P9MSCE1C01	192705	F.19	P9MSCX0E01	193170	F.19	P9MSLD0G	184593	F.20	P9MSMU1N	184230	F.16
P9MSCE1C38	192718	F.19	P9MSCX0E95	184471	F.19	P9MSLD0I	184598	F.20	P9MSMU3N	184310	F.16
P9MSCE1C95	184440	F.19	P9MSCX0F95	184472	F.19	P9MSLD0L	184596	F.20	P9MSMU3V	184312	F.16
P9MSCE1E95	184441	F.19	P9MSCX0J95	184473	F.19	P9MSLD0R	184591	F.20	P9MSMU5N	184270	F.16
P9MSCE1N02	192736	F.19	P9MSCX0M95	184476	F.19	P9MSLD0V	184592	F.20	P9MSMWN	184360	F.16
P9MSCE1N95	184442	F.19	P9MSCX0R95	184478	F.19	P9MSLD00	184609	F.20	P9MSMWOR	184361	F.16
P9MSCE3C95	184464	F.19	P9MSCX0V95	184481	F.19	P9MSL20A	184605	F.20	P9MSMWOV	184362	F.16
P9MSCE5A01	192885	F.19	P9MSCX0Z01	193335	F.19	P9MSL20B	184607	F.20	P9MSMX00	184339	F.16
P9MSCE5A34	192896	F.19	P9MSCX0Z34	193346	F.19	P9MSL20G	184603	F.20	P9MSMX0G	184333	F.16
P9MSCE5A38	192898	F.19	P9MSCX0Z38	193348	F.19	P9MSL20I	184608	F.20	P9MSMX0N	184397	F.16
P9MSCE5A95	184452	F.19	P9MSCX0Z95	184482	F.19	P9MSL20L	184606	F.20	P9MSMX0R	184331	F.16
P9MSCE5C01	192900	F.19	P9MSCX5A95	184483	F.19	P9MSL20R	184601	F.20	P9MSMX0V	184332	F.16
P9MSCE5C34	192911	F.19	P9MSCX5D95	184485	F.19	P9MSL20V	184602	F.20	P9MSMX5N	184340	F.16
P9MSCE5C95	184453	F.19	P9MSCX5F95	184486	F.19	P9MSL21B	184617	F.20	P9MSMY0N	184350	F.16
P9MSCE5H02	192919	F.19	P9MSCX5R01	193400	F.19	P9MSL21G	184613	F.20	P9MSMV0R	184351	F.16
P9MSCE5H95	184454	F.19	P9MSCX5R95	184489	F.19	P9MSL21I	184616	F.20	P9MSMZ00	184209	F.16
P9MSCH0A02	192196	F.18	P9MSCZ0A05	192604	F.18	P9MSL21R	184611	F.20	P9MSMZ0G	184203	F.16
P9MSCH0A95	184406	F.18	P9MSCZ0A33	192610	F.18	P9MSL21V	184612	F.20	P9MSMZ0L	184206	F.16
P9MSCH0C02	192211	F.18	P9MSCZ0A34	192611	F.18	P9MSL23A	184635	F.20	P9MSMZ0N	184200	F.16
P9MSCH0C95	184407	F.18	P9MSCZ0A37	192612	F.18	P9MSL23B	184637	F.20	P9MSMZ0R	184201	F.16
P9MSCH0H34	192236	F.18	P9MSCZ0A38	192613	F.18	P9MSL23G	184633	F.20	P9MSMZ0V	184202	F.16
P9MSCH0H95	184408	F.18	P9MSCZ0A40	192614	F.18	P9MSL23I	184638	F.20	P9MSMZ1G	184243	F.16
P9MSCH1C95	184411	F.18	P9MSCZ0A95	184433	F.18	P9MSL23L	184636	F.20	P9MSMZ1N	184240	F.16
P9MSCIO001	192150	F.18	P9MSCZ0C01	192615	F.18	P9MSL23R	184631	F.20	P9MSMZ1R	184241	F.16
P9MSCIO002	192151	F.18	P9MSCZ0C02	192616	F.18	P9MSL23V	184632	F.20	P9MSMZ1V	184242	F.16
P9MSCIO003	192152	F.18	P9MSCZ0C03	192617	F.18	P9MSL25A	184625	F.20	P9MSMZ3G	184323	F.16
P9MSCIO004	192153	F.18	P9MSCZ0C04	192618	F.18	P9MSL25B	184627	F.20	P9MSMZ3L	184326	F.16
P9MSCIO005	192154	F.18	P9MSCZ0C05	192619	F.18	P9MSL25G	184623	F.20	P9MSMZ3N	184320	F.16
P9MSCIO010	192155	F.18	P9MSCZ0C33	192625	F.18	P9MSL25I	184628	F.20	P9MSMZ3R	184321	F.16
P9MSCIO016	192156	F.18	P9MSCZ0C34	192626	F.18	P9MSL25L	184626	F.20	P9MSMZ3V	184322	F.16
P9MSCIO019	192157	F.18	P9MSCZ0C37	192627	F.18	P9MSL25R	184621	F.20	P9MSMZ5G	184283	F.16
P9MSCIO033	192160	F.18	P9MSCZ0C38	192628	F.18	P9MSL25V	184622	F.20	P9MSMZ5L	184286	F.16
P9MSCIO034	192161	F.18	P9MSCZ0C95	184434	F.18	P9MSM53291	153291	F.16	P9MSMZ5N	184280	F.16
P9MSCIO037	192162	F.18	P9MSCZ0E34	192641	F.18	P9MSM53293	153293	F.16	P9MSMZ5V	184282	F.16
P9MSCIO038	192163	F.18	P9MSCZ0E37	192642	F.18	P9MSM53305	153305	F.16	P9MSVD0G	184822	F.17
P9MSCIO040	192164	F.18	P9MSCZ0E38	192643	F.18	P9MSM53391	153391	F.16	P9MSVD0L	184823	F.17
P9MSCIO053	192158	F.18	P9MSCZ0E95	184435	F.18	P9MSM53392	153392	F.16	P9MSVD0N	184370	F.17
P9MSCIO095	184403	F.18	P9MSCZ0H33	192655	F.18	P9MSM53393	153393	F.16	P9MSVD0R	184820	F.17
P9MSCIOE01	192165	F.18	P9MSCZ0H95	184436	F.18	P9MSM55003	155003	F.16	P9MSVD0V	184821	F.17
P9MSCIOE02	192166	F.18	P9MSCZ0K01	192660	F.18	P9MSMD00	184119	F.16	P9MSVD5G	184834	F.17
P9MSCIOE19	192172	F.18	P9MSCZ0K95	184437	F.18	P9MSMD0G	184113	F.16	P9MSVD5N	184373	F.17
P9MSCIOE40	192179	F.18	P9MSCZ0N33	192685	F.18	P9MSMD0L	184116	F.16	P9MSVD5R	184832	F.17
P9MSCIOE95	184404	F.18	P9MSCZ0N34	192686	F.18	P9MSMD0N	184110	F.16	P9MSVD5V	184833	F.17
P9MSCION01	192180	F.18	P9MSCZ0N95	184438	F.18	P9MSMD0R	184111	F.16	P9MSVE0N	184376	F.17
P9MSCION33	192190	F.18	P9MSCZ0T01	192690	F.18	P9MSMD0V	184112	F.16	P9MSVE0V	184845	F.17

Controls Alphabetical Index

Cat. no.	Ref. no	Cat. pg	Cat. no.	Ref. no	Cat. pg	Cat. no.	Ref. no	Cat. pg	Cat. no.	Ref. no	Cat. pg
P9MSVE1N	184380	F.17	P9PLNVJB	197007	F.25	P9SPNV	186012	F.13	P9KET4GN1	185063	F.13
P9MSVE1R	184860	F.17	P9PLNVJG	197008	F.25	P9SRG	186771	F.22	P9KET4LL1	185566	
P9MSVE3N	184388	F.17	P9PLNVJL	197009	F.25	P9SSCD0A95	186400	F.18	P9KET4LL2	185576	
P9MSVE5N	184384	F.17	P9PLNVJR	197010	F.25	P9SSCD0K33	198055	F.18	P9KET4LN1	185066	F.13
P9MSVH0N	184372	F.17	P9PLNVJV	197011	F.25	P9SSCD0K34	198056	F.18	P9KETANN1	185057	F.13
P9MSVHOR	184828	F.17	P9PLNVNA	197012	F.25	P9SSCD0K37	198057	F.18	P9KETANN2	185080	F.13
P9MSVH1N	184375	F.17	P9PLNVNB	197013	F.25	P9SSCD0K38	198058	F.18	P9KETARL1	185561	
P9MSVH1R	184840	F.17	P9PLNVNG	197014	F.25	P9SSCD0K40	198059	F.18	P9KET4RL2	185571	
P9MSVH0N	184371	F.17	P9PLNVNL	197015	F.25	P9SSCD0K95	186402	F.18	P9KET4RL3	185581	
P9MSVHOR	184824	F.17	P9PLNVNR	197016	F.25	P9SSCD5A95	186409	F.19	P9KETARN1	185061	F.13
P9MSVH5N	184374	F.17	P9PLNVNV	197017	F.25	P9SSCI5C95	186410	F.19	P9KETARN2	185081	F.13
P9MSVH5R	184836	F.17	P9PRDBN	187072	F.25	P9SSC20T95	186439	F.19	P9KETARN3	185091	F.13
P9MSVH5V	184837	F.17	P9PRDVB	187022	F.25	P9SSC23C95	186467	F.19	P9KET4VL1	185562	
P9MSVH0N	184377	F.17	P9PREVJ	187025	F.25	P9SSC25A95	186461	F.19	P9KET4VL2	185572	
P9MSVH1N	184381	F.17	P9PREVL	187026	F.25	P9SSLD00	186599	F.20	P9KET4VL3	185582	
P9MSVH3N	184389	F.17	P9PRLBJ	187071	F.25	P9SSLD08	186597	F.20	P9KET52121	152121	
P9MSVH5N	184385	F.17	P9PRLVJ	187021	F.25	P9SSLD0G	186593	F.20	P9XL00	185799	
P9MSVU0G	184854	F.17	P9PRNVJ	187023	F.25	P9SSLD0I	186598	F.20	P9XLS2651	152651	
P9MSVU0N	184378	F.17	P9PRNVN	187024	F.25	P9SSLD0L	186596	F.20	P9XLS2652	152652	
P9MSVU1N	184382	F.17	P9PRTVN	187028	F.25	P9SSLD0R	186591	F.20	P9XLAD	185795	F.14
P9MSVU3N	184390	F.17	P9PTMVG	187051	F.25	P9SSLD0V	186592	F.20	P9XLAR	185805	F.14
P9MSVU5N	184386	F.17	P9PTMVJ	187045	F.25	P9SSL20B	186607	F.20	P9XLBD	185797	F.14
P9MSVW0G	184922	F.17	P9PTMVN	187046	F.25	P9SSL20R	186601	F.20	P9XLBR	185807	F.14
P9MSVW0N	184395	F.17	P9PTMVU	187047	F.25	P9SSL20V	186602	F.20	P9XLS2610	152610	
P9MSVWOR	184920	F.17	P9PTMVV	187048	F.25	P9SSL23L	186636	F.20	P9XLS2611	152611	
P9MSVW0V	184921	F.17	P9PTNVG	187036	F.25	P9SSL23R	186631	F.20	P9XLS2612	152612	
P9MSVX0G	184910	F.17	P9PTNVH	187037	F.25	P9SSL23V	186632	F.20	P9XLS2613	152613	
P9MSVX0L	184911	F.17	P9PTNVJ	187030	F.25	P9SSMD00	186119	F.16	P9XLS2614	152614	
P9MSVX0N	184392	F.17	P9PTNVN	187031	F.25	P9SSMD0L	186116	F.16	P9XLS2620	152620	
P9MSVX0R	184908	F.17	P9PTNVR	187038	F.25	P9SSMD0N	186110	F.16	P9XLS2621	152621	
P9MSVX0V	184909	F.17	P9PTNVU	187032	F.25	P9SSMD0R	186111	F.16	P9XLS2622	152622	
P9MSVX5N	184393	F.17	P9PTNVV	187033	F.25	P9SSMD0V	186112	F.16	P9XLGD	185793	F.14
P9MSVY0N	184394	F.17	P9PTNVY	187034	F.25	P9SSMD5N	186140	F.16	P9XLGR	185803	F.14
P9MSVY0V	184917	F.17	P9PTNVZ	187035	F.25	P9SSME0N	186170	F.16	P9XLID	185798	F.14
P9MSVZ0G	184858	F.17	P9RSCZ3C95	242632	F.19	P9SSMESN	185787	F.16	P9XLID	185796	F.14
P9MSVZ0N	184379	F.17	P9RSMY0N	242631	F.16	P9SSMI0N	186120	F.16	P9XLLR	185806	F.14
P9MSVZ0R	184856	F.17	P9SBD	186773	F.22	P9SSMI5N	186150	F.16	P9XLVL	185830	F.14
P9MSVZ0V	184857	F.17	P9SBM	186774	F.22	P9SSMISV	185786	F.16	P9XLVD	185791	F.14
P9MSVZ1G	184874	F.17	P9SCC	186697	F.21	P9SSMU0N	186190	F.16	P9XLR	185801	F.14
P9MSVZ1N	184383	F.17	P9SCD	186695	F.21	P9SSMU1N	186230	F.16	P9XLVD	185792	F.14
P9MSVZ3G	184906	F.17	P9SEC4RA37	198012		P9SSMX0N	186330	F.16	P9XLVR	185802	F.14
P9MSVZ3L	184907	F.17	P9SEC4RA38	198013		P9SSM200	186209	F.16	P9XMB2A	185712	F.23
P9MSVZ3N	184391	F.17	P9SEC4RA95	186073		P9SSM20N	186200	F.16	P9XMB2B	185713	F.23
P9MSVZ3R	184904	F.17	P9SEM3NN	186030	F.13	P9SSM20V	186202	F.16	P9XMB2BG	185716	F.23
P9MSVZ3V	184905	F.17	P9SEM3RL	186551	F.13	P9SSM21N	186240	F.16	P9XMB2F	185710	F.23
P9MSVZ5G	184890	F.17	P9SEM3RN	186031	F.13	P9SSM230	186329	F.16	P9XMB2T	185711	F.23
P9MSVZ5N	184387	F.17	P9SEM3VN	186032	F.13	P9SSM23N	186320	F.16	P9XMBAF	185740	F.23
P9MWR	184770	F.22	P9SER4RA	186072	F.13	P9SSM25N	186280	F.16	P9XMBAT	185741	F.23
P9MZ	184772	F.22	P9SET4AL3	186585		P9S2	186772	F.22	P9XMN2A	185702	F.23
P9PDMVD	187040	F.25	P9SET4BL1	186567		P9TLVR	191802		P9XMN2B	185703	F.23
P9PDMVJ	187041	F.25	P9SET4BL3	186587		P9TPLRGD	191491	F.20	P9XMN2F	185700	F.23
P9PDNBO	187070	F.26	P9SET4GL1	186563		P9TZ	191772	F.22	P9XMN2FG	185708	F.23
P9PDNFO	187055	F.25	P9SET4NN1	185785	F.13	P9XBD	185773	F.22	P9XMN2T	185701	F.23
P9PDNVD	187079	F.25	P9SET4RL1	186561		P9XBM	185774	F.22	P9XMN2TG	185715	F.23
P9PDNVL	187080	F.25	P9SET4RN1	186061	F.13	P9XC	185696		P9XMN2UG	185707	F.23
P9PDNVO	187020	F.25	P9SL00	186799		P9XCC	185697		P9XMNAC	185722	F.23
P9PDTVO	187027	F.25	P9SLAD	186795	F.14	P9XCD	185695	F.21	P9XMN4F	185720	F.23
P9PLFVDA	197018	F.25	P9SLBD	186797	F.14	P9XCARA01	195000		P9XMNAG	185723	F.23
P9PLFVDB	197019	F.25	P9SLGD	186793	F.14	P9XCARA04	195003		P9XMNAM	185726	F.23
P9PLFVDG	197020	F.25	P9SLID	186798	F.14	P9XCARA33	195010		P9XMNAT	185721	F.23
P9PLFVDL	197021	F.25	P9SLLD	186796	F.14	P9XCARA37	195012		P9XMMATG	185731	F.23
P9PLFVDR	197022	F.25	P9SLRD	186791	F.14	P9XCARA95N	185079		P9XPCN1E95	185103	
P9PLFVDV	197023	F.25	P9SLVD	186792	F.14	P9XCARN01	196455		P9XPCN1K37	195027	
P9PLFVJB	197025	F.25	P9SPLOEO	186519	F.20	P9XCARN05	196459		P9XPCN1K95	185100	
P9PLFVJG	197026	F.25	P9SPLOGO	186499	F.20	P9XCARN37	196467		P9XPL0EO	185519	F.20
P9PLFVJR	197028	F.25	P9SPLOSO	186509	F.20	P9XEC4RN95	185074		P9XPL0GO	185499	F.20
P9PLFVJV	197029	F.25	P9SPL54513	154513	F.20	P9XEC50777	150777		P9XPL0SO	185509	F.20
P9PLFVNB	197031	F.25	P9SPLAGD	186495	F.20	P9XEM3NN	185030	F.13	P9XPL52502	152502	F.20
P9PLFVNG	197032	F.25	P9SPLASD	186505	F.20	P9XEM3RN	185031	F.13	P9XPL52503	152503	F.20
P9PLFVNL	197033	F.25	P9SPLBGD	186497	F.20	P9XEM4AL	185555	F.13	P9XPL52511	152511	F.20
P9PLFVNR	197034	F.25	P9SPLBSD	186507	F.20	P9XEM4GL	185553	F.13	P9XPL52513	152513	F.20
P9PLFVNV	197035	F.25	P9SPLGGD	186493	F.20	P9XEM4GN	185043	F.13	P9XPL52514	152514	F.20
P9PLNBDA	197036	F.20	P9SPLGSD	186503	F.20	P9XEM4GN099	185054	F.13	P9XPL52515	152515	F.20
P9PLNBDB	197037	F.20	P9SPLIED	186518	F.20	P9XEM4LN	185046	F.13	P9XPL52530	152530	F.20
P9PLNBDB	197038	F.20	P9SPLIGD	186498	F.20	P9XEM4NN	185040	F.13	P9XPL52531	152531	F.20
P9PLNBDL	197039	F.20	P9SPLISD	186508	F.20	P9XEM4RL	185551	F.13	P9XPL52561	152561	F.20
P9PLNBDR	197040	F.20	P9SPLLGD	186496	F.20	P9XEM4RN	185041	F.13	P9XPLAGD	185495	F.20
P9PLNB0V	197041	F.20	P9SPLISD	186506	F.20	P9XEM4VL	185552	F.13	P9XPLASD	185505	F.20
P9PLNBJA	197042	F.20	P9SPLRGD	186491	F.20	P9XEM4VN	185042	F.13	P9XPLBGD	185497	F.20
P9PLNBJB	197043	F.20	P9SPLRSD	186501	F.20	P9XEM52111	152111	F.13	P9XPLBSD	185507	F.20
P9PLNBJG	197044	F.20	P9SPLVGD	186492	F.20	P9XEM52112	152112	F.13	P9XPLGSD	185493	F.20
P9PLNB0L	197045	F.20	P9SPLVSD	186502	F.20	P9XEM6NN	185050	F.13	P9XPLGSD	185503	F.20
P9PLNB0V	197047	F.20	P9SPNOG	186009	F.13	P9XEM6RN	185051	F.13	P9XPLIGD	185498	F.20
P9PLNBNA	197048	F.20	P9SPNOS	186019	F.13	P9XEM6VN	185052	F.13	P9XPLISD	185508	F.20
P9PLNB0B	197049	F.20	P9SPN0G	186007	F.13	P9XER3RN	185070	F.13	P9XPLLGD	185496	F.20
P9PLNB0G	197050	F.20	P9SPN0G	186003	F.13	P9XER3VN	185075	F.13	P9XPLISD	185506	F.20
P9PLNB0R	197052	F.20	P9SPN0G	186013	F.13	P9XERANN	185024	F.13	P9XPLRGD	185491	F.20
P9PLNB0V	197053	F.20	P9SPN0G	186008	F.13	P9XERARA	185072	F.13	P9XPLRSD	185501	F.20
P9PLNVDA	197000	F.25	P9SPNLG	186006	F.13	P9XERARAN	185077	F.13	P9XPLVGD	185492	F.20
P9PLNVDB	197001	F.25	P9SPNLS	186016	F.13	P9XERARAW	185078	F.13	P9XPLVSD	185502	F.20
P9PLNV0G	197002	F.25	P9SPNNG	186000	F.13	P9XERARN	185071	F.13	P9XPN0G	185009	F.13
P9PLNV0L	197003	F.25	P9SPNNS	186010	F.13	P9XERS0775	150775	F.13	P9XPN0S	185019	F.13
P9PLNVDR	197004	F.25	P9SPNRG	186001	F.13	P9XERS2160	152160	F.13	P9XPN52001	152001	F.13
P9PLNV0V	197005	F.25	P9SPNRS	186011	F.13	P9XERW50776	150776	F.13	P9XPN52002	152002	F.13
P9PLNVJA	197006	F.25	P9SPNVG	186002	F.13	P9KET4GL1	185563		P9XPN52007	152007	F.13



Controls Alphabetical Index

Cat. no.	Ref. no	Cat. pg	Cat. no.	Ref. no	Cat. pg	Cat. no.	Ref. no	Cat. pg	Cat. no.	Ref. no	Cat. pg
P9XPN52008	152008	F.13	P9XSCU0N95	185431	F.18	P9XSMU00	185199	F.16	P9YPNLS	185916	F.13
P9XPN52009	152009	F.13	P9XSCU0T37	195597	F.18	P9XSMU0N	185190	F.16	P9YPNNG	185900	F.13
P9XPN52010	152010	F.13	P9XSCU0T95	185432	F.18	P9XSMU0R	185191	F.16	P9YPNVG	185902	F.13
P9XPN52011	152011	F.13	P9XSCX0A37	196137	F.18	P9XSMU1N	185230	F.16	P9YSCD0A95	185970	F.18
P9XPN52012	152012	F.13	P9XSCX0B95	185469	F.18	P9XSMU1R	185231	F.16	P9YSCD0T95	185980	F.18
P9XPN52061	152061	F.13	P9XSCX0Z01	196335	F.18	P9XSMU3N	185310	F.16	P9YSM00N	185960	F.16
P9XPNBDG	205249	F.13	P9XSCX0Z95	185482	F.18	P9XSMW0N	185360	F.16	P9YSMZ0N	185962	F.16
P9XPNBG	185007	F.13	P9XSCX5L95	185488	F.19	P9XSMX0N	185330	F.16	PRC1S13BDL	222004	B.5
P9XPNGG	185003	F.13	P9XSCX5R95	185489	F.19	P9XSMX0V	185559	F.16	PRC1S13BNL	222013	B.5
P9XPNGS	185013	F.13	P9XSCZ0A01	185790	F.18	P9XSMX5N	185340	F.16	PRC1S13CBL	222007	B.5
P9XPNHG	185008	F.13	P9XSCZ0A38	195613	F.18	P9XSMY0N	185350	F.16	PRC1S13CCL	222008	B.5
P9XPNLG	185006	F.13	P9XSCZ0A95	185433	F.18	P9XSMZ00	185209	F.16	PRC1T10ADL	221868	B.5
P9XPNLRG	205250	F.13	P9XSCZ0C95	185434	F.18	P9XSMZ0N	185200	F.16	PRC1T10AJL	221869	B.5
P9XPNLS	185016	F.13	P9XSCZ0E95	185435	F.18	P9XSMZ0R	185201	F.16	PRC1T10ANL	221870	B.5
P9XPNNG	185000	F.13	P9XSCZ0H95	185436	F.18	P9XSMZ0V	185202	F.16	PRC1T10CBL	221860	B.5
P9XPNNS	185010	F.13	P9XSCZ0N33	195685	F.18	P9XSMZ1N	185240	F.16	PRC1T10CCL	221861	B.5
P9XPNRG	185001	F.13	P9XSCZ0T01	195690	F.18	P9XSMZ3G	185323	F.16	PRC1T10CJL	221862	B.5
P9XPNRS	185011	F.13	P9XSCZ0T02	195691	F.18	P9XSMZ3N	185320	F.16	PRC1T20ADL	221883	B.5
P9XPNVG	185002	F.13	P9XSCZ0T34	195701	F.18	P9XSMZ3RD	155000	F.16	PRC1T20AJL	221884	B.5
P9XPNVS	185012	F.13	P9XSCZ0T38	195703	F.18	P9XSMZ3V	185322	F.16	PRC1T20ANL	221885	B.5
P9XPNWUG	205248	F.13	P9XSCZ0T95	185439	F.18	P9XSMZ5N	185280	F.16	PRC1T20CBL	221875	B.5
P9XRG	185771	F.22	P9XSCZ1C95	185449	F.18	P9XSV00G	183802	F.17	PRC1T20CCL	221876	B.5
P9XSAD08	185647	F.20	P9XSCZ1E95	185490	F.18	P9XSV00N	185370	F.17	PRC1T20CJL	221877	B.5
P9XSAD0G	185643	F.20	P9XSCZ1N95	185451	F.18	P9XSV00V	183801	F.17	PRC2P20ABL	220019	B.4
P9XSAD0L	185646	F.20	P9XSCZ3C01	196110	F.19	P9XSV05N	185373	F.17	PRC2P20ADL	220020	B.4
P9XSAD0V	185642	F.20	P9XSCZ3C34	196121	F.19	P9XSV0E0N	185376	F.17	PRC2P20AGL	220021	B.4
P9XSAZ0R	185651	F.20	P9XSCZ3C38	196123	F.19	P9XSV0E1N	185380	F.17	PRC2P20AJL	220022	B.4
P9XSAZ1I	185668	F.20	P9XSCZ3C95	185467	F.19	P9XSV0E3R	183872	F.17	PRC2P20ANL	220026	B.4
P9XSAZ3R	185687	F.20	P9XSCZ5A95	185461	F.19	P9XSVH0N	185372	F.17	PRC2P20CBL	220022	B.4
P9XSAZ38	185681	F.20	P9XSCZ5C95	185462	F.19	P9XSVI0N	185371	F.17	PRC2P20CCL	220023	B.4
P9XSAZ3V	185682	F.20	P9XSCZ5H95	185463	F.19	P9XSVI0R	183804	F.17	PRC2P20CGL	220025	B.4
P9XSAZ5V	185672	F.20	P9XSLD00	185599	F.20	P9XSVI5N	185374	F.17	PRC2P20CJL	220027	B.4
P9XSC52434	152434	F.19	P9XSLD0A	185595	F.20	P9XSVL0N	185577	F.17	PRC2P20CBL	220041	B.4
P9XSC52435	152435	F.19	P9XSLD0B	185597	F.20	P9XSVL1N	185381	F.17	PRC2P20CCL	220042	B.4
P9XSC52496	152496	F.19	P9XSLD0G	185593	F.20	P9XSVU1N	185382	F.17	PRC2P20DCGL	220043	B.4
P9XSC52497	152497	F.19	P9XSLD0I	185598	F.20	P9XSVU3N	185390	F.17	PRC2P20DCJL	220044	B.4
P9XSCD0A01	195105	F.18	P9XSLD0L	185596	F.20	P9XSVU5N	185386	F.17	PRC3P30ABL	220310	B.4
P9XSCD0A02	195106	F.18	P9XSLD0R	185591	F.20	P9XSVW0N	185395	F.17	PRC3P30ADL	220311	B.4
P9XSCD0A03	195107	F.18	P9XSLD0V	185592	F.20	P9XSVX0N	185392	F.17	PRC3P30AGL	220312	B.4
P9XSCD0A04	195108	F.18	P9XSLZ00	185609	F.20	P9XSVX5N	185393	F.17	PRC3P30AJL	220315	B.4
P9XSCD0A05	195109	F.18	P9XSLZ0B	185607	F.20	P9XSVY0N	185394	F.17	PRC3P30ANL	220317	B.4
P9XSCD0A10	195110	F.18	P9XSLZ0G	185603	F.20	P9XSVZ0G	183838	F.17	PRC3P30CBL	220313	B.4
P9XSCD0A16	195111	F.18	P9XSLZ0I	185608	F.20	P9XSVZ0L	183839	F.17	PRC3P30CCL	220314	B.4
P9XSCD0A19	195112	F.18	P9XSLZ0L	185606	F.20	P9XSVZ0N	185379	F.17	PRC3P30CGL	220316	B.4
P9XSCD0A33	195115	F.18	P9XSLZ0R	185601	F.20	P9XSVZ1N	185383	F.17	PRC3P30CJL	220318	B.4
P9XSCD0A34	195116	F.18	P9XSLZ0V	185602	F.20	P9XSVZ3L	183887	F.17	PRC3P30CNL	220319	B.4
P9XSCD0A37	195117	F.18	P9XSLZ1A	185615	F.20	P9XSVZ3N	185391	F.17	PRC3P30CBL	220335	B.4
P9XSCD0A38	195118	F.18	P9XSLZ1I	185618	F.20	P9XSVZ5N	185387	F.17	PRC3P30CCL	220336	B.4
P9XSCD0A40	195119	F.18	P9XSLZ1R	185611	F.20	P9XSVZ5V	183869	F.17	PRC3P30CGL	220337	B.4
P9XSCD0A53	195113	F.18	P9XSLZ1V	185612	F.20	P9XU00RN	185849	F.14	PRC3P30CJL	220338	B.4
P9XSCD0A95	185400	F.18	P9XSLZ3A	185635	F.20	P9XUAD0	185825	F.14	PRC4M20ABL	220710	B.3
P9XSCD0E05	195124	F.18	P9XSLZ3B	185637	F.20	P9XUADRN	185845	F.14	PRC4M20ADL	220711	B.3
P9XSCD0E33	195130	F.18	P9XSLZ3G	185633	F.20	P9XUARRN	185855	F.14	PRC4M20AGL	220712	B.3
P9XSCD0E37	195132	F.18	P9XSLZ3I	185638	F.20	P9XUBDD0	185827	F.14	PRC4M20AJL	220715	B.3
P9XSCD0E95	185401	F.18	P9XSLZ3L	185636	F.20	P9XUBDDJ	205242	F.14	PRC4M20ABL	220717	B.3
P9XSCD0K01	195135	F.18	P9XSLZ3R	185631	F.20	P9XUBDRN	205247	F.14	PRC4M20CBL	220713	B.3
P9XSCD0K02	195136	F.18	P9XSLZ3V	185632	F.20	P9XUBDDN	213705	F.14	PRC4M20CCL	220714	B.3
P9XSCD0K33	195145	F.18	P9XSLZ5G	185623	F.20	P9XUBDRN	185847	F.14	PRC4M20CGL	220716	B.3
P9XSCD0K34	195146	F.18	P9XSLZ5I	185628	F.20	P9XUBR0D	185837	F.14	PRC4M20CJL	220718	B.3
P9XSCD0K37	195147	F.18	P9XSLZ5L	185626	F.20	P9XUBRRN	185857	F.14	PRC4M20CCL	220029	B.3
P9XSCD0K38	195148	F.18	P9XSLZ5R	185621	F.20	P9XUGDD0	185823	F.14	PRC4M20CML	220046	B.3
P9XSCD0K40	195149	F.18	P9XSLZ5V	185622	F.20	P9XUGDDJ	205240	F.14	PRC4M20CBL	220754	B.3
P9XSCD0K95	185402	F.18	P9XSM52290	152290	F.16	P9XUGDDJ	205245	F.14	PRC4M20DCGL	220755	B.3
P9XSCD5A34	195251	F.19	P9XSM52293	152293	F.16	P9XUGDDN	213703	F.14	PRC4M20DCJL	220756	B.3
P9XSCD5A95	185409	F.19	P9XSM52390	152390	F.16	P9XUGDRN	185843	F.14	PRC4M20DCCL	220757	B.3
P9XSCD5A98	195298	F.18	P9XSM52391	152391	F.16	P9XUGR0D	185833	F.14	PRC4M20DCKL	220028	B.3
P9XSCD5C03	195302	F.18	P9XSM52392	152392	F.16	P9XUGRRN	185853	F.14	PRC4M20DCML	220045	B.3
P9XSCD5C08	195358	F.18	P9XSM52393	152393	F.16	P9XUIDD0	185828	F.14	PRC4M30ABL	221051	B.3
P9XSCD5T01	195375	F.18	P9XSM000	185119	F.16	P9XUIDRN	185848	F.14	PRC4M30ADL	221052	B.3
P9XSCD5T37	195387	F.18	P9XSM00G	185113	F.16	P9XULDD0	185826	F.14	PRC4M30AGL	221053	B.3
P9XSCD5T95	185418	F.18	P9XSM00L	185116	F.16	P9XULDDJ	205241	F.14	PRC4M30AJL	221056	B.3
P9XSCD5E1C95	185440	F.19	P9XSM00N	185110	F.16	P9XULDDV	205246	F.14	PRC4M30ANL	221058	B.3
P9XSCD5E3A34	195896	F.19	P9XSM00R	185111	F.16	P9XULD0N	213704	F.14	PRC4M30CBL	221054	B.3
P9XSCD5E3A38	195898	F.19	P9XSM00V	185112	F.16	P9XULDNR	185846	F.14	PRC4M30CCL	221055	B.3
P9XSCD5E3A95	185452	F.19	P9XSM05G	185143	F.16	P9XULRRN	185856	F.14	PRC4M30CGL	221057	B.3
P9XSCD5E3H95	185454	F.19	P9XSM05L	185146	F.16	P9XURDD0	185821	F.14	PRC4M30CJL	221059	B.3
P9XSCH0A95	185406	F.18	P9XSM05N	185140	F.16	P9XURDDJ	205238	F.14	PRC4M30CCL	220031	B.3
P9XSCH0C95	185407	F.18	P9XSM05V	185142	F.16	P9XURDDN	205243	F.14	PRC4M30CML	220048	B.3
P9XSCH1C34	195281	F.18	P9XSM0E0N	185170	F.16	P9XURDDV	213701	F.14	PRC4M30DCBL	221074	B.3
P9XSCH1C01	195150	F.18	P9XSM0E0V	185172	F.16	P9XURDRN	185841	F.14	PRC4M30DCCL	221075	B.3
P9XSCH1C02	195151	F.18	P9XSM0E1N	185210	F.16	P9XURR0D	185831	F.14	PRC4M30DCGL	221076	B.3
P9XSCH1C03	195163	F.18	P9XSM0E1R	185211	F.16	P9XURRRN	185851	F.14	PRC4M30DCJL	221077	B.3
P9XSCH1C095	185403	F.18	P9XSM0E3L	185296	F.16	P9XUVDD0	185822	F.14	PRC4M30DCKL	220030	B.3
P9XSCH1E037	195177	F.18	P9XSM0E3N	185290	F.16	P9XUVDDJ	205239	F.14	PRC4M30DCML	220047	B.3
P9XSCH1E095	185404	F.18	P9XSM0E5R	185251	F.16	P9XUVDDV	205244	F.14	PRC4M40ABL	221809	B.3
P9XSCH1N95	185405	F.18	P9XSMH0G	185133	F.16	P9XUVDDN	213702	F.14	PRC4M40ADL	221810	B.3
P9XSCH1SC01	195255	F.19	P9XSMH0R	185131	F.16	P9XUVDRN	185842	F.14	PRC4M40AGL	221811	B.3
P9XSCH1SC33	195265	F.19	P9XSMH1N	185160	F.16	P9XUVR0D	185832	F.14	PRC4M40AJL	221814	B.3
P9XSCH1SC34	195266	F.19	P9XSMION	185120	F.16	P9XUVRRN	185852	F.14	PRC4M40ANL	221816	B.3
P9XSCH1SC38	195268	F.19	P9XSMISN	185150	F.16	P9XVZ	185772	F.22	PRC4M40CBL	221812	B.3
P9XSCH1SC40	195269	F.19	P9XSMISR	185151	F.16	P9YEMARN	185920	F.13	PRC4M40CCL	221813	B.3
P9XSCH1SC95	185410	F.19	P9XSMLOV	185182	F.16	P9YERARA	185921	F.13	PRC4		

Controls Alphabetical Index

Alphabetical index

Cat. no.	Ref. no	Cat. pg	Cat. no.	Ref. no	Cat. pg	Cat. no.	Ref. no	Cat. pg	Cat. no.	Ref. no	Cat. pg
PRCAM40DCBL	221851	B.3	RL4RA022GR	104913	B.15	RL4RD022TB	113020	B.15	RT1F	113703	A.55
PRCAM40DCDL	221852	B.3	RL4RA022GS	104911	B.15	RL4RD022TD	113026	B.15	RT1G	113704	A.55
PRCAM40DCGL	221853	B.3	RL4RA022GU	104916	B.15	RL4RD022TG	113027	B.15	RT1GB	139600	A.55
PRCAM40DCJL	221854	B.3	RL4RA022GV	104915	B.15	RL4RD022TH	113070	B.15	RT1GC	139601	A.55
PRCAM40DCKL	220032	B.3	RL4RA022GW	104917	B.15	RL4RD022TJ	113028	B.15	RT1GD	139602	A.55
PRCAM40DCML	220049	B.3	RL4RA022GX	104918	B.15	RL4RD022TK	113072	B.15	RT1GF	139603	A.55
PRCG011	220648	B.4	RL4RA022GY	104919	B.15	RL4RD022TN	113029	B.15	RT1GG	139604	A.55
PRCG08	220217	B.4	RL4RA022GZ	104920	B.15	RL4RD022TT	113075	B.15	RT1GH	139605	A.55
PRCG1052	220914	B.3	RL4RA022R1	241466	B.15	RL4RD022TU	113035	B.15	RT1GJ	139606	A.55
PRCG-ES15/2N	220912	B.3	RL4RA022R6	211540	B.15	RL4RD022TVD	113014	B.15	RT1GK	139607	A.55
PRCG-ES15/3N	221442	B.3	RL4RA022R7	101688	B.15	RL4RD022TWE	101148	B.15	RT1GL	139608	A.55
PRCG-ES15/4N	221934	B.3	RL4RA022RJ	108870	B.15	RL4RD022TWG	101150	B.15	RT1GM	139609	A.55
PRCGZT80	221918	B.5	RL4RA022RN	108873	B.15	RL4RD022TWI	113004	B.15	RT1GN	139610	A.55
PRCM21N	222101	B.6	RL4RA022RS	108856	B.15	RL4RD022TWJ	113002	B.15	RT1GP	139611	A.55
PRCM21P	222100	B.6	RL4RA022TI	109064	B.15	RL4RD022TWK	104951	B.15	RT1GS	139612	A.55
PRCM31G	222104	B.6	RL4RA022T15	247924	B.15	RL4RD022TWN	247939	B.15	RT1GW	139616	A.55
PRCM31R	222102	B.6	RL4RA022T2	109065	B.15	RL4RD022TX	113076	B.15	RT1H	113705	A.55
PRCM32G	222105	B.6	RL4RA022T6	109069	B.15	RL4RD031RD	108875	B.15	RT1J	113706	A.55
PRCM32R	222103	B.6	RL4RA022T7	109070	B.15	RL4RD031RK	101114	B.15	RT1K	113707	A.55
PRCM33G	222106	B.6	RL4RA022T9	113983	B.15	RL4RD031RWI	113011	B.15	RT1L	113708	A.55
PRCM33R	222109	B.6	RL4RA022TJ	104023	B.15	RL4RD031RWID	248154	B.15	RT1LMP	139197	A.55
PRCM41G	222107	B.6	RL4RA022TK	109053	B.15	RL4RD031RWJ	104932	B.15	RT1M	113709	A.55
PRCM41R	222110	B.6	RL4RA022TL	109054	B.15	RL4RD031TB	113010	B.15	RT1MMP	139219	A.55
PRCM42G	222124	B.6	RL4RA022TN	104024	B.15	RL4RD031TD	113016	B.15	RT1N	113710	A.55
PRCM42R	222111	B.6	RL4RA022TS	109056	B.15	RL4RD031TG	113017	B.15	RT1NMP	139220	A.55
PRCM43G	222125	B.6	RL4RA022TU	104025	B.15	RL4RD031TH	113061	B.15	RT1P	113711	A.55
PRCM43R	222112	B.6	RL4RA022TV	109060	B.15	RL4RD031TJ	113018	B.15	RT1PMP	139198	A.55
PRCM51	222113	B.6	RL4RA022TV	109062	B.15	RL4RD031TB	113063	B.15	RT1RB	114087	A.55
PRCM52	222114	B.6	RL4RA031R1	108852	B.15	RL4RD031TT	113019	B.15	RT1RC	114131	A.55
PRCM53	222115	B.6	RL4RA031R6	101136	B.15	RL4RD031TN	113066	B.15	RT1RD	114089	A.55
PRCM71	222121	B.6	RL4RA031R7	101690	B.15	RL4RD031TWD	113013	B.15	RT1RF	114090	A.55
PRCM73	222122	B.6	RL4RA031RJ	108869	B.15	RL4RD031TWE	101152	B.15	RT1RG	114091	A.55
PRCM91G	222126	B.6	RL4RA031RN	108872	B.15	RL4RD031TWG	247869	B.15	RT1RH	114092	A.55
PRCM91R	222116	B.6	RL4RA031T1	109040	B.15	RL4RD031TWI	113003	B.15	RT1RJ	114093	A.55
PRCM93G	222120	B.6	RL4RA031T2	109041	B.15	RL4RD031TWJ	113015	B.15	RT1RK	114094	A.55
PRCM516	221920	B.6	RL4RA031T6	109045	B.15	RL4RD031TWV	247007	B.15	RT1RL	114095	A.55
PRCM535	220915	B.6	RL4RA031T7	109046	B.15	RL4RD040RD	108874	B.15	RT1RM	114096	A.55
PRCP211	220218	B.4	RL4RA031T9	113964	B.15	RL4RD040RG	104934	B.15	RT1RN	114097	A.55
PRCR159	220219	B.4	RL4RA031TJ	104013	B.15	RL4RD040RK	101113	B.15	RT1RP	114098	A.55
PRCT1AD	221896	B.5	RL4RA031TK	109029	B.15	RL4RD040RWD	113095	B.15	RT1RS	114099	A.55
PRCT1AJ	221897	B.5	RL4RA031TL	109030	B.15	RL4RD040RWD	248153	B.15	RT1RT	114100	A.55
PRCT1AN	221898	B.5	RL4RA031TN	104014	B.15	RL4RD040RWJ	104933	B.15	RT1RU	114101	A.55
PRCT1CB	221890	B.5	RL4RA031TU	104015	B.15	RL4RD040TB	113000	B.15	RT1RV	114102	A.55
PRCT1CD	221891	B.5	RL4RA031TV	109038	B.15	RL4RD040TD	113006	B.15	RT1RW	114103	A.55
PRCT1CJ	221892	B.5	RL4RA040R1	108851	B.15	RL4RD040TG	113007	B.15	RT1S	113712	A.55
PRCT2AB	221912	B.5	RL4RA040R3	104890	B.15	RL4RD040TH	113052	B.15	RT1T	113713	A.55
PRCT2AD	221913	B.5	RL4RA040R4	101691	B.15	RL4RD040TJ	113008	B.15	RT1TMP	139221	A.55
PRCT2AJ	221914	B.5	RL4RA040R6	101138	B.15	RL4RD040TK	113054	B.15	RT1U	113714	A.55
PRCT2AN	221915	B.5	RL4RA040R7	101692	B.15	RL4RD040TN	113009	B.15	RT1JUMP	139199	A.55
PRCT2CB	221905	B.5	RL4RA040RJ	108868	B.15	RL4RD040TT	113057	B.15	RT1V	113715	A.55
PRCT2CD	221906	B.5	RL4RA040RN	108871	B.15	RL4RD040TWD	113012	B.15	RT1VMP	202692	A.55
PRCT2CJ	221907	B.5	RL4RA040RU	101104	B.15	RL4RD040TWE	101154	B.15	RT1W	113716	A.55
PRCTR	221921	B.5	RL4RA040T1	109016	B.15	RL4RD040TWG	247870	B.15	RT2D	113650	A.55
PRCTR1	220916	B.3	RL4RA040T2	109017	B.15	RL4RD040TWI	113005	B.15	RT2E	113651	A.55
PRCTR1S	222043	B.3	RL4RA040T4	109019	B.15	RL4RD040TWJ	109421	B.15	RT2G	113652	A.55
PRC211	220647	B.4	RL4RA040T6	109021	B.15	RL4RD040TWN	101156	B.15	RT2GD	114076	A.55
PRC2B	220216	B.4	RL4RA040T7	109022	B.15	RL4RD040TX	113058	B.15	RT2GE	114077	A.55
RE1D	101866	A.59	RL4RA040T9	101693	B.15	RMLFB	112989	A.44	RT2GG	114078	A.55
RE1H	101867	A.59	RL4RA040TJ	104003	B.15	RMLFD	112992	A.44	RT2GH	114079	A.55
RE1K	101868	A.59	RL4RA040TK	109005	B.15	RMLFG	112993	A.44	RT2GJ	114080	A.55
RE1M	101869	A.59	RL4RA040TL	109006	B.15	RMLFJ	112994	A.44	RT2GL	114081	A.55
RE1S	101870	A.59	RL4RA040TN	104004	B.15	RMLFN	112995	A.44	RT2GM	114082	A.55
RE1W	101871	A.59	RL4RA040TU	104005	B.15	RMLFU	112996	A.44	RT2H	113653	A.55
RE1XP	247302	A.59	RL4RA040TV	109014	B.15	RMLFY	112997	A.44	RT2J	113654	A.55
RE2H	101872	A.59	RL4RD004RK	112999	B.15	RT12D	139138		RT2L	113655	A.55
RE2M	101873	A.59	RL4RD004TB	113030	B.15	RT12F	139139		RT2M	113656	A.55
RE2XP	247303	A.59	RL4RD004TD	113036	B.15	RT12G	139140		RT2A	113717	A.55
RE3E	101874	A.59	RL4RD004TG	113037	B.15	RT12GK	114066		RT2B	113718	A.55
RETC	247795	A.59	RL4RD004TH	113079	B.15	RT12GL	114067		RT2C	113719	A.55
RL4RA004R7	101685	B.15	RL4RD004TK	113038	B.15	RT12GM	114068		RT2D	113720	A.55
RL4RA004RJ	101117	B.15	RL4RD004TK	113081	B.15	RT12GN	114069		RT2E	113721	A.55
RL4RA004T1	109088	B.15	RL4RD004TN	113039	B.15	RT12GP	114070		RT2G	113722	A.55
RL4RA004T2	109089	B.15	RL4RD004TT	113084	B.15	RT12GS	114071		RT2GA	139617	A.55
RL4RA004T6	109093	B.15	RL4RD004TWE	101140	B.15	RT12GT	114072		RT2GB	139618	A.55
RL4RA004T7	109094	B.15	RL4RD004TWG	101142	B.15	RT12GU	114073		RT2GC	139619	A.55
RL4RA004T9	101686	B.15	RL4RD004TWI	101144	B.15	RT12GV	114074		RT2GD	139620	A.55
RL4RA004TJ	104033	B.15	RL4RD004TWJ	104974	B.15	RT12GW	114075		RT2GJ	139624	A.55
RL4RA004TK	109077	B.15	RL4RD004TWN	101146	B.15	RT12H	139141		RT2GL	139625	A.55
RL4RA004TL	109078	B.15	RL4RD004TX	113085	B.15	RT12J	139142		RT2GM	139626	A.55
RL4RA004TN	104034	B.15	RL4RD022GB	113040	B.15	RT12K	113640		RT2H	113723	A.55
RL4RA004TU	104035	B.15	RL4RD022GD	113046	B.15	RT12L	113641		RT2J	113724	A.55
RL4RA004TV	109086	B.15	RL4RD022GG	113047	B.15	RT12M	113642		RT2L	113725	A.55
RL4RA022G1	104921	B.15	RL4RD022GH	113088	B.15	RT12N	113643		RT2M	113726	A.55
RL4RA022G2	104922	B.15	RL4RD022GJ	113048	B.15	RT12P	113644		RT2RB	114132	A.55
RL4RA022G3	104923	B.15	RL4RD022GK	113090	B.15	RT12RK	114114		RT2RD	114133	A.55
RL4RA022G4	104924	B.15	RL4RD022GN	113049	B.15	RT12RU	114121		RT2RE	114134	A.55
RL4RA022G5	104925	B.15	RL4RD022GP	113091	B.15	RT12RW	114123		RT2RG	114109	A.55
RL4RA022G6	104926	B.15	RL4RD022GT	113093	B.15	RT12S	113645		RT2RH	114146	A.55
RL4RA022G7	104927	B.15	RL4RD022GX	113094	B.15	RT12T	113646		RT2RL	114235	A.55
RL4RA022G8	104928	B.15	RL4RD022RD	108876	B.15	RT12U	113647		RT2RM	114113	A.55
RL4RA022GC	104900	B.15	RL4RD022RG	113025	B.15	RT12V	113648		RT2XP	113764	A.57
RL4RA022GH	104905	B.15	RL4RD022RK	101115	B.15	RT12W	113649		RT2XC	113657	A.56
RL4RA022GJ	104907	B.15	RL4RD022RT	104899	B.15	RT1B	113700	A.55	RT32D	113658	A.56
RL4RA022GK	104908	B.15	RL4RD022RWD	104929	B.15	RT1C	113701	A.55	RT32E	113659	A.56
RL4RA022GN	104912	B.15	RL4RD022RWJ	104931	B.15	RT1D	113702	A.55	RT32F	113660	A.56



Controls Alphabetical Index

Cat. no.	Ref. no	Cat. pg	Cat. no.	Ref. no	Cat. pg	Cat. no.	Ref. no	Cat. pg	Cat. no.	Ref. no	Cat. pg
RT32GC	114083	A.56	RTN2D	114022		V31110CA	133581				
RT32GD	114084	A.56	RTN2E	114023		V31111BG	133290				
RT32GE	114085	A.56	RTN2G	114025		V31111CA	133582				
RT32GF	114086	A.56	RTN2H	114026		V31111CE	113146				
RT3B	113727	A.56	RTN2J	114027		V31112BAG	133583				
RT3C	113728	A.56	RTN2L	114029		V31113BAG	133584				
RT3D	113729	A.56	RTN2M	114030		V311175BA	116950				
RT3E	113730	A.56	RTN3C	114032		V311175CAG	136056				
RT3F	113731	A.56	RTN3D	114033		V31185BAG	136058				
RT3GB	139627	A.56	RTN3F	114035		V31195BAG	136060				
RT3GC	139628	A.56	RTN4N	114036		V31200WB	138792				
RT3GD	139629	A.56	RTN4P	114037		V31201WB	138793				
RT3GE	139630	A.56	RTN5C	114041		V31202WB	138794				
RT3GF	139631	A.56	RTX3	113762		V31206BG	116576				
RT4GN	139632	A.56	RTX8S	108864	A.57	V31207BG	116577				
RT4GP	139633	A.56	RTX8SG	139599		V31208BG	116579				
RT4GR	139634	A.56	RTXG3	139664		V31209BG	116581				
RT4LA	113735	A.56	RTXL	113763		V31209BJ	133384				
RT4LB	113736	A.56	RTXP	105170		V31210BG	116582				
RT4LC	113737	A.56	RTXRRB	113661	A.57	V31225WB	138795				
RT4LD	113738	A.56	RTXRRD	113662	A.57	V31235BG	116572				
RT4LE	113739	A.56	RTXRRDG	136452	A.57	V31245BG	116574				
RT4LF	113740	A.56	RTXRRG	113663	A.57	VB1203B	133170				
RT4LG	113741	A.56	RTXRRJ	113664	A.57	VB1203BG	116571				
RT4LGA	139635	A.56	RTXRRJG	136454	A.57	VB1204B	133885				
RT4LGB	139636	A.56	RTXRRN	113665	A.57	VB1204BG	116573				
RT4LGC	139637	A.56	RTXRRNG	136455	A.57	VB1205BG	116575				
RT4LGD	139638	A.56	RTXRRU	113666	A.57	VB1207BG	116578				
RT4LGE	139639	A.56	RTXRRUG	136456	A.57	VB1208BG	116580				
RT4LGF	139640	A.56	RTXRRX	113667	A.57	WKLI02P	101422	A.45			
RT4LGG	139641	A.56	RTXS	113855	A.57	WKMIU	101421	A.45			
RT4LGH	139642	A.56	RTXSL	113856	A.57	WKMIUG	107067	A.45			
RT4LGJ	139643	A.56	SFAI11	120024	C.27						
RT4LGK	139644	A.56	SFAK10	120026	C.27						
RT4LGL	139645	A.56	SFAK10	120025	C.27						
RT4LGM	139646	A.56	SFALL1D	120022	C.27						
RT4LGN	139647	A.56	SFALL1N	120020	C.27						
RT4LGP	139648	A.56	SFALL1S	120027	C.27						
RT4LGR	139649	A.56	SFAL20D	120023	C.27						
RT4LH	113742	A.56	SFAL20N	120021	C.27						
RT4LJ	113743	A.56	SFALPEN	264826	C.27						
RT4LK	113744	A.56	SFBOAJ	120030	C.27						
RT4LL	113745	A.56	SFBOAN	120031	C.27						
RT4LM	113746	A.56	SFBOAU	120032	C.27						
RT4LN	113747	A.56	SFBORJ	120034	C.27						
RT4LP	113748	A.56	SFBORJM	107256	C.27						
RT4LR	113749	A.56	SFBORN	120035	C.27						
RT4N	113752	A.56	SFBORNM	120114	C.27						
RT4P	113753	A.56	SFBORU	120036	C.27						
RT4R	113754	A.56	SFBORUM	120115	C.27						
RT5A	113750	A.56	SFE04	120042	C.28						
RT5B	113751	A.56	SFE04K1	216604	C.28						
RT5C	113752	A.56	SFE05	120043	C.28						
RT5D	113753	A.56	SFE0K2	120047	C.28						
RT5E	113754	A.56	SFK0A	120001	C.26						
RT5GA	139650	A.56	SFK0B	120002	C.26						
RT5GB	139651	A.56	SFK0C	120003	C.26						
RT5GC	139652	A.56	SFK0D	120004	C.26						
RT5GD	139653	A.56	SFK0E	120005	C.26						
RT5GE	139654	A.56	SFK0F	120006	C.26						
RT5LA	113755	A.56	SFK0G	120007	C.26						
RT5LB	113756	A.56	SFK0H	120008	C.26						
RT5LC	113757	A.56	SFK0I	120009	C.26						
RT5LD	113758	A.56	SFK0J	120010	C.26						
RT5LE	113759	A.56	SFK0K	120011	C.26						
RT5LGB	139656	A.56	SFK0L	120012	C.26						
RT5LGC	139657	A.56	SFK0M	120013	C.26						
RT5LGD	139658	A.56	SFPE0	120053	C.28						
RT5LGE	139659	A.56	SFPRO	120052	C.28						
RT6A	113760	A.56	SFPS0	120051	C.28						
RT6GA	139660	A.56	SFS04	120040	C.28						
RT6LA	113761	A.56	SFS04K1	245217	C.28						
RT6LGA	139661	A.56	SFS04M	212558	C.28						
RTMM2AN	124084		SFS05	120041	C.28						
RTMM2AU	124085		SFS05M	212559	C.28						
RTN1B	114000		SFS0K2	120046	C.28						
RTN1C	114001		SFV88	254537	C.9 / C.29						
RTN1D	114002		SFVDC	120054	C.28						
RTN1F	114004		SFVH03	120050	C.27						
RTN1G	114005		V1107BA	113612	A.51						
RTN1H	114006		V1108BA	113505	A.51						
RTN1J	114007		V1108CA	113614	A.51						
RTN1K	114008		V1109BA	113899	A.51						
RTN1L	114009		V1109BA	113616	A.51						
RTN1M	114010		V1110CE	113618	A.51						
RTN1N	114011		V1111CE	113619	A.51						
RTN1P	114012		V1112BA	113620	A.51						
RTN1S	114014		V1113BA	113621	A.51						
RTN1T	114015		V1175CA	113613	A.51						
RTN1U	114016		V1185BA	113615	A.51						
RTN1V	114017		V1195BA	113617	A.51						
RTN1W	114018		V31107BAG	136055							
RTN2A	114019		V31108CAG	136057							
RTN2B	114020		V31109BAG	136062							
RTN2C	114021		V31110BG	136917							



Power Electronics Alphabetical Index

Alphabetical index

Cat. no.	Ref. no	Cat. pg	Cat. no.	Ref. no	Cat. pg	Cat. no.	Ref. no	Cat. pg	Cat. no.	Ref. no	Cat. pg
6KFP23001X2RXC1	6KFP23001X2RXC1	G.52	6KFP23050X9XXCA1	404695	G.52	6KFP43025X9XXCA1	403863	G.52	6KFP43200X2RXC1	409704	G.52
6KFP23001X2RXXA1	6KFP23001X2RXXA1	G.52	6KFP23060X2RXC1	404709	G.52	6KFP43030X1XXCA1	404578	G.52	6KFP43200X2XXCB1	409687	G.52
6KFP23001X2XXCA1	6KFP23001X2XXCA1	G.52	6KFP23060X2XXCA1	404709	G.52	6KFP43030X1XXCA1	404578	G.52	6KFP43200X9RXC1	409693	G.52
6KFP23001X2XXCA1	404697	G.52	6KFP23060X2XXCA1	404709	G.52	6KFP43030X2RXC1	404578	G.52	6KFP43200X9XXCB1	409680	G.52
6KFP23001X9RXC1	6KFP23001X9RXC1	G.52	6KFP23060X9RXC1	404709	G.52	6KFP43030X2XXCA1	404578	G.52	6KFP43200X2RXC1	409705	G.52
6KFP23001X9XXA1	6KFP23001X9XXA1	G.52	6KFP23060X9XXCA1	404709	G.52	6KFP43030X2XXCA1	403956	G.52	6KFP43250X2XXCB1	409688	G.52
6KFP23001X9XXCA1	6KFP23001X9XXCA1	G.52	6KFP23060X9XXCA1	404709	G.52	6KFP43030X2XXCA1	403895	G.52	6KFP43250X9RXC1	409694	G.52
6KFP23001X9XXCA1	404684	G.52	6KFP23060X9XXCA1	404696	G.52	6KFP43030X4XXCA1	409573	G.52	6KFP43250X9XXCB1	409682	G.52
6KFP23002X2RXC1	6KFP23002X2RXC1	G.52	6KFP23060X9XXCA1	404696	G.52	6KFP43030X9RXC1	404557	G.52	6KFP43300X2RXC1	409706	G.52
6KFP23002X2RXXA1	6KFP23002X2RXXA1	G.52	6KFP23060X9XXCA1	404696	G.52	6KFP43030X9XXCA1	403982	G.52	6KFP43300X2XXCB1	409689	G.52
6KFP23002X2XXCA1	6KFP23002X2XXCA1	G.52	6KFP23060X9XXCA1	404696	G.52	6KFP43030X9XXCA1	403935	G.52	6KFP43300X9RXC1	409695	G.52
6KFP23002X2XXCA1	404698	G.52	6KFP23060X9XXCA1	403947	G.52	6KFP43030X9XXCA1	403864	G.52	6KFP43300X9XXCB1	409683	G.52
6KFP23002X9RXC1	6KFP23002X9RXC1	G.52	6KFP43001X2RXC1	403886	G.52	6KFP43040X1XXCA1	6KFP43040X1XXCA1	G.52	6KFP43350X2RXC1	409707	G.52
6KFP23002X9XXA1	6KFP23002X9XXA1	G.52	6KFP43001X2XXCA1	403886	G.52	6KFP43040X1XXCA1	6KFP43040X1XXCA1	G.52	6KFP43350X2XXCB1	409690	G.52
6KFP23002X9XXCA1	6KFP23002X9XXCA1	G.52	6KFP43001X4XXCA1	409564	G.52	6KFP43040X2RXC1	404579	G.52	6KFP43350X9RXC1	409700	G.52
6KFP23002X9XXCA1	404685	G.52	6KFP43001X9RXC1	404548	G.52	6KFP43040X2XXCA1	404467	G.52	6KFP43350X9XXCB1	409684	G.52
6KFP23003X2RXC1	6KFP23003X2RXC1	G.52	6KFP43001X9XXCA1	403973	G.52	6KFP43040X2XXCA1	403957	G.52	6KFP43450X1RXC1	404544	G.52
6KFP23003X2RXXA1	6KFP23003X2RXXA1	G.52	6KFP43001X9XXCA1	403926	G.52	6KFP43040X2XXCA1	403896	G.52	6KFP43450X1XXCA1	403922	G.52
6KFP23003X2XXCA1	6KFP23003X2XXCA1	G.52	6KFP43001X9XXCA1	403855	G.52	6KFP43040X4XXCA1	409574	G.52	6KFP43450X2RXC1	409708	G.52
6KFP23003X2XXCA1	404699	G.52	6KFP43002X2RXC1	404210	G.52	6KFP43040X9RXC1	404558	G.52	6KFP43450X2XXCB1	409691	G.52
6KFP23003X9RXC1	6KFP23003X9RXC1	G.52	6KFP43002X2XXCA1	403948	G.52	6KFP43040X9XXCA1	403983	G.52	6KFP43450X9RXC1	409702	G.52
6KFP23003X9XXA1	6KFP23003X9XXA1	G.52	6KFP43002X2XXCA1	403887	G.52	6KFP43040X9XXCA1	403936	G.52	6KFP43450X9XXCB1	409685	G.52
6KFP23003X9XXCA1	6KFP23003X9XXCA1	G.52	6KFP43002X4XXCA1	409565	G.52	6KFP43040X9XXCA1	403865	G.52	6KFP43500X1RXC1	404545	G.52
6KFP23003X9XXCA1	404686	G.52	6KFP43002X9RXC1	404549	G.52	6KFP43050X1XXCA1	6KFP43050X1XXCA1	G.52	6KFP43500X1XXCA1	403923	G.52
6KFP23005X2RXC1	6KFP23005X2RXC1	G.52	6KFP43002X9XXCA1	403974	G.52	6KFP43050X1XXCA1	6KFP43050X1XXCA1	G.52	6KFP43500X2RXC1	404528	G.52
6KFP23005X2RXXA1	6KFP23005X2RXXA1	G.52	6KFP43002X9XXCA1	403927	G.52	6KFP43050X2RXC1	404580	G.52	6KFP43500X2XXCA1	403908	G.52
6KFP23005X2XXCA1	6KFP23005X2XXCA1	G.52	6KFP43002X9XXCA1	403856	G.52	6KFP43050X2XXCA1	404468	G.52	6KFP43500X8RXC1	403995	G.52
6KFP23005X2XXCA1	404700	G.52	6KFP43003X2RXC1	404571	G.52	6KFP43050X2XXCA1	403958	G.52	6KFP43500X8XXCA1	403877	G.52
6KFP23005X9RXC1	6KFP23005X9RXC1	G.52	6KFP43003X2XXCA1	404263	G.52	6KFP43050X2XXCA1	403897	G.52	6KFP43550X1RXC1	404546	G.52
6KFP23005X9XXA1	6KFP23005X9XXA1	G.52	6KFP43003X2XXCA1	403949	G.52	6KFP43050X4XXCA1	409575	G.52	6KFP43550X1XXCA1	403924	G.52
6KFP23005X9XXCA1	6KFP23005X9XXCA1	G.52	6KFP43003X2XXCA1	403888	G.52	6KFP43050X9RXC1	404559	G.52	6KFP43550X2RXC1	404529	G.52
6KFP23005X9XXCA1	404687	G.52	6KFP43003X4XXCA1	409566	G.52	6KFP43050X9XXCA1	403984	G.52	6KFP43550X2XXCA1	403909	G.52
6KFP23007X2RXC1	6KFP23007X2RXC1	G.52	6KFP43003X9RXC1	404550	G.52	6KFP43050X9XXCA1	403937	G.52	6KFP43550X8RXC1	403996	G.52
6KFP23007X2RXXA1	6KFP23007X2RXXA1	G.52	6KFP43003X9XXCA1	403975	G.52	6KFP43050X9XXCA1	403866	G.52	6KFP43550X8XXCA1	403878	G.52
6KFP23007X2XXCA1	6KFP23007X2XXCA1	G.52	6KFP43003X9XXCA1	403928	G.52	6KFP43060X1XXCA1	6KFP43060X1XXCA1	G.52	6KFP43600X1RXC1	404547	G.52
6KFP23007X2XXCA1	404701	G.52	6KFP43003X9XXCA1	403857	G.52	6KFP43060X1XXCA1	6KFP43060X1XXCA1	G.52	6KFP43600X1XXCA1	403925	G.52
6KFP23007X9RXC1	6KFP23007X9RXC1	G.52	6KFP43005X2RXC1	404572	G.52	6KFP43060X2RXC1	404581	G.52	6KFP43600X2RXC1	404532	G.52
6KFP23007X9XXA1	6KFP23007X9XXA1	G.52	6KFP43005X2XXCA1	404293	G.52	6KFP43060X2XXCA1	404469	G.52	6KFP43600X2XXCA1	403910	G.52
6KFP23007X9XXCA1	6KFP23007X9XXCA1	G.52	6KFP43005X2XXCA1	403950	G.52	6KFP43060X2XXCA1	403959	G.52	6KFP43600X8RXC1	403997	G.52
6KFP23007X9XXCA1	404688	G.52	6KFP43005X2XXCA1	403889	G.52	6KFP43060X2XXCA1	403898	G.52	6KFP43600X8XXCA1	403879	G.52
6KFP23101X2RXC1	6KFP23101X2RXC1	G.52	6KFP43005X4XXCA1	409567	G.52	6KFP43060X4XXCA1	409576	G.52	6KFP43650X1RXC1	403998	G.52
6KFP23101X2RXXA1	6KFP23101X2RXXA1	G.52	6KFP43005X9RXC1	404551	G.52	6KFP43060X9RXC1	404560	G.52	6KFP43650X1XXCA1	403880	G.52
6KFP23101X2XXCA1	6KFP23101X2XXCA1	G.52	6KFP43005X9XXCA1	403976	G.52	6KFP43060X9XXCA1	403985	G.52	6KFP43650X2RXC1	404533	G.52
6KFP23101X2XXCA1	404702	G.52	6KFP43005X9XXCA1	403929	G.52	6KFP43060X9XXCA1	403938	G.52	6KFP43650X2XXCA1	403911	G.52
6KFP23101X9RXC1	6KFP23101X9RXC1	G.52	6KFP43005X9XXCA1	403858	G.52	6KFP43060X9XXCA1	403867	G.52	6KFP43750X1RXC1	403999	G.52
6KFP23101X9XXA1	6KFP23101X9XXA1	G.52	6KFP43007X2RXC1	404573	G.52	6KFP43075X1XXCA1	6KFP43075X1XXCA1	G.52	6KFP43750X1XXCA1	403881	G.52
6KFP23101X9XXCA1	6KFP23101X9XXCA1	G.52	6KFP43007X2XXCA1	404387	G.52	6KFP43075X1XXCA1	6KFP43075X1XXCA1	G.52	6KFP43750X2RXC1	404534	G.52
6KFP23101X9XXCA1	404689	G.52	6KFP43007X2XXCA1	403951	G.52	6KFP43075X2RXC1	404582	G.52	6KFP43750X2XXCA1	403912	G.52
6KFP23101X9XXCA1	6KFP23101X9XXCA1	G.52	6KFP43007X2XXCA1	403890	G.52	6KFP43075X2XXCA1	404470	G.52	6KFP43900X1RXC1	404000	G.52
6KFP23101X9XXCA1	6KFP23101X9XXCA1	G.52	6KFP43007X4XXCA1	409568	G.52	6KFP43075X2XXCA1	403960	G.52	6KFP43900X1XXCA1	403882	G.52
6KFP23101X9XXCA1	6KFP23101X9XXCA1	G.52	6KFP43007X9RXC1	404552	G.52	6KFP43075X2XXCA1	403899	G.52	6KFP43900X2RXC1	404535	G.52
6KFP23101X9XXCA1	404703	G.52	6KFP43007X9XXCA1	403977	G.52	6KFP43075X4XXCA1	409577	G.52	6KFP43900X2XXCA1	403913	G.52
6KFP23101X9XXCA1	6KFP23101X9XXCA1	G.52	6KFP43007X9XXCA1	403930	G.52	6KFP43075X9RXC1	404561	G.52	6KFP63015X1RXC1	404865	G.52
6KFP23101X9XXCA1	6KFP23101X9XXCA1	G.52	6KFP43007X9XXCA1	403859	G.52	6KFP43075X9XXCA1	403986	G.52	6KFP63015X1XXCA1	404866	G.52
6KFP23101X9XXCA1	6KFP23101X9XXCA1	G.52	6KFP43010X2RXC1	404574	G.52	6KFP43075X9XXCA1	403939	G.52	6KFP63015X2RXC1	404867	G.52
6KFP23101X9XXCA1	404690	G.52	6KFP43010X2XXCA1	404388	G.52	6KFP43075X9XXCA1	403868	G.52	6KFP63015X2XXCA1	404868	G.52
6KFP23202X2RXC1	6KFP23202X2RXC1	G.52	6KFP43100X2XXCA1	403952	G.52	6KFP43100X1XXCA1	6KFP43100X1XXCA1	G.52	6KFP63020X1RXC1	404869	G.52
6KFP23202X2RXXA1	6KFP23202X2RXXA1	G.52	6KFP43100X2XXCA1	403891	G.52	6KFP43100X1XXCA1	6KFP43100X1XXCA1	G.52	6KFP63020X1XXCA1	404870	G.52
6KFP23202X2XXCA1	6KFP23202X2XXCA1	G.52	6KFP43100X4XXCA1	409569	G.52	6KFP43100X2RXC1	404583	G.52	6KFP63020X2RXC1	404871	G.52
6KFP23202X2XXCA1	404704	G.52	6KFP43100X9RXC1	404553	G.52	6KFP43100X2XXCA1	404471	G.52	6KFP63020X2XXCA1	404872	G.52
6KFP23202X9RXC1	6KFP23202X9RXC1	G.52	6KFP43100X9XXCA1	403978	G.52	6KFP43100X2XXCA1	403961	G.52	6KFP63025X1RXC1	404873	G.52
6KFP23202X9XXA1	6KFP23202X9XXA1	G.52	6KFP43100X9XXCA1	403931	G.52	6KFP43100X2XXCA1	403900	G.52	6KFP63025X1XXCA1	404874	G.52
6KFP23202X9XXCA1	6KFP23202X9XXCA1	G.52	6KFP43100X9XXCA1	403860	G.52	6KFP43100X4XXCA1	409578	G.52	6KFP63025X2RXC1	404875	G.52
6KFP23202X9XXCA1	404691	G.52	6KFP43015X1XXCA1	6KFP43015X1XXCA1	G.52	6KFP43100X9RXC1	404562	G.52	6KFP63025X2XXCA1	404876	G.52
6KFP23202X9XXCA1	6KFP23202X9XXCA1	G.52	6KFP43015X1XXCA1	6KFP43015X1XXCA1	G.52	6KFP43100X9XXCA1	403987	G.52	6KFP63030X1RXC1	404877	G.52
6KFP23202X9XXCA1	6KFP23202X9XXCA1	G.52	6KFP43015X2RXC1	404575	G.52	6KFP43100X9XXCA1	403940	G.52	6KFP63030X1XXCA1	404878	G.52
6KFP23202X9XXCA1	6KFP23202X9XXCA1	G.52	6KFP43015X2XXCA1	404389	G.52	6KFP43100X9XXCA1	403869	G.52	6KFP63030X2RXC1	404879	G.52
6KFP23202X9XXCA1	404705	G.52	6KFP43015X2XXCA1	403953	G.52	6KFP43125X1XXCA1	6KFP43125X1XXCA1	G.52	6KFP63030X2XXCA1	404880	G.52
6KFP23202X9XXCA1	6KFP23202X9XXCA1	G.52	6KFP43015X2XXCA1	403892	G.52	6KFP43125X1XXCA1	6KFP43125X1XXCA1	G.52	6KFP63040X1RXC1	404881	G.52
6KFP23202X9XXCA1	6KFP23202X9XXCA1	G.52	6KFP43015X4XXCA1	409570	G.52	6KFP43125X2RXC1	404584	G.52	6KFP63040X1XXCA1	404882	G.52
6KFP23202X9XXCA1	6KFP23202X9XXCA1	G.52	6KFP43015X9RXC1	404554	G.52	6KFP43125X2XXCA1	404472	G.52	6KFP63040X2RXC1	404883	G.52
6KFP23202X9XXCA1	404692	G.52	6KFP43015X9XXCA1	403979	G.52	6KFP43125X2XXCA1	403962	G.52	6KFP63040X2XXCA1	404884	G.52
6KFP232030X2RXC1	6KFP232030X2RXC1	G.52	6KFP43015X9XXCA1	403932	G.52	6KFP43125X2XXCA1	403901	G.52	6KFP63050X1RXC1	404885	G.52
6KFP232030X2RXXA1	6KFP232030X2RXXA1	G.52	6KFP43015X9XXCA1	403861	G.52	6KFP43125X4XXCA1	409563	G.52	6KFP63050X1XXCA1	404886	G.52
6KFP232030X2XXCA1	6KFP232030X2XXCA1	G.52	6KFP43202X1XXCA1	6KFP43202X1XXCA1	G.52	6KFP43125X9RXC1	404563	G.52	6KFP63050X2RXC1	404887	G.52
6KFP232030X2XXCA1	404706	G.52	6KFP43202X1XXCA1	6KFP43202X1XXCA1	G.52	6KFP43125X9XXCA1	403988	G.52	6KFP63050X2XXCA1		

Power Electronics Alphabetical Index

Cat. no.	Ref. no	Cat. pg	Cat. no.	Ref. no	Cat. pg	Cat. no.	Ref. no	Cat. pg	Cat. no.	Ref. no	Cat. pg
6KGP43200X9RCB1	409609	G.34	6KGP43900X2RBCA1	403271	G.34	6KGP63040X1RXXA1	403619	G.34	6KGP631K2X2XBCA1	403703	G.34
6KGP43200X9RCB1	409621	G.34	6KGP43900X2RBCA1	403297	G.34	6KGP63040X1XBCA1	403799	G.34	6KGP631K2X2XXCA1	403604	G.34
6KGP43200X9RCB1	409602	G.34	6KGP43900X2RBCA1	403184	G.34	6KGP63040X1XBCA1	403646	G.34	6KGP631K3X1XBCA1	403666	G.34
6KGP43250X2RBCB1	409643	G.34	6KGP43900X2XXCA1	402916	G.34	6KGP63040X1XXCA1	403745	G.34	6KGP631K3X1XXCA1	403569	G.34
6KGP43250X2RBCB1	409616	G.34	6KGP43F50X2RBCA1	403505	G.34	6KGP63040X1XXCA1	403549	G.34	6KGP631K3X2XBCA1	403704	G.34
6KGP43250X2RBCB1	409631	G.34	6KGP43F50X2RBCA1	403243	G.34	6KGP63040X2RBCA1	403835	G.34	6KGP631K3X2XXCA1	403605	G.34
6KGP43250X2RBCB1	409649	G.34	6KGP43F50X2RBCA1	403379	G.34	6KGP63040X2RBCA1	403727	G.34	6KGP631K6X1XBCA1	404738	G.34
6KGP43250X9RCB1	409637	G.34	6KGP43F50X2RXXA1	402975	G.34	6KGP63040X2RXXA1	403781	G.34	6KGP631K6X1XXCA1	404739	G.34
6KGP43250X9RCB1	409610	G.34	6KGP43F50X2RXXA1	403442	G.34	6KGP63040X2RXXA1	403628	G.34	6KGP631K6X2XBCA1	404740	G.34
6KGP43250X9RCB1	409622	G.34	6KGP43F50X2RXXA1	403156	G.34	6KGP63040X2RXXA1	403808	G.34	6KGP631K6X2XXCA1	404741	G.34
6KGP43250X9RCB1	409603	G.34	6KGP43F50X2XXCA1	403316	G.34	6KGP63040X2RXXA1	403684	G.34	6KGP63200X2XBCB1	409674	G.34
6KGP43300X2RBCB1	409644	G.34	6KGP43F50X2XXCA1	402888	G.34	6KGP63040X2XXCA1	403754	G.34	6KGP63200X2XXCB1	409660	G.34
6KGP43300X2RBCB1	409617	G.34	6KGP43F50X4RBCA1	403526	G.34	6KGP63040X2XXCA1	403585	G.34	6KGP63200X9XBCB1	409667	G.34
6KGP43300X2RBCB1	409632	G.34	6KGP43F50X4RBCA1	403274	G.34	6KGP63050X1RBCA1	403827	G.34	6KGP63200X9XXCB1	409653	G.34
6KGP43300X2XXCB1	409650	G.34	6KGP43F50X4RXXA1	403400	G.34	6KGP63050X1RXXA1	403719	G.34	6KGP63250X2XBCB1	409675	G.34
6KGP43300X9RCB1	409638	G.34	6KGP43F50X4RXXA1	403100	G.34	6KGP63050X1RXXA1	403773	G.34	6KGP63250X2XXCB1	409661	G.34
6KGP43300X9RCB1	409611	G.34	6KGP43F50X4XXCA1	403463	G.34	6KGP63050X1XXCA1	403620	G.34	6KGP63250X9XBCB1	409668	G.34
6KGP43300X9RCB1	409623	G.34	6KGP43F50X4XXCA1	403187	G.34	6KGP63050X1XXCA1	403800	G.34	6KGP63250X9XXCB1	409654	G.34
6KGP43300X9XXCB1	409604	G.34	6KGP43F50X4XXCA1	403337	G.34	6KGP63050X1XXCA1	403647	G.34	6KGP63300X2XBCB1	409676	G.34
6KGP43350X1RBCA1	403239	G.34	6KGP43F50X4XXCA1	402919	G.34	6KGP63050X1XXCA1	403746	G.34	6KGP63300X2XXCB1	409662	G.34
6KGP43350X1RBCA1	402971	G.34	6KGP43F50X9RBCA1	403479	G.34	6KGP63050X1XXCA1	403550	G.34	6KGP63300X9XBCB1	409669	G.34
6KGP43350X1XBCA1	403152	G.34	6KGP43F50X9RXXA1	403203	G.34	6KGP63050X2RBCA1	403836	G.34	6KGP63300X9XXCB1	409655	G.34
6KGP43350X1XBCA1	402884	G.34	6KGP43F50X9RXXA1	403353	G.34	6KGP63050X2RXXA1	403728	G.34	6KGP63350X2XBCB1	409677	G.34
6KGP43350X2RBCB1	409645	G.34	6KGP43F50X9RXXA1	402935	G.34	6KGP63050X2RXXA1	403782	G.34	6KGP63350X2XXCB1	409663	G.34
6KGP43350X2RBCB1	409618	G.34	6KGP43F50X9RXXA1	403416	G.34	6KGP63050X2RXXA1	403629	G.34	6KGP63350X9XBCB1	409670	G.34
6KGP43350X2XXCB1	409633	G.34	6KGP43F50X9XXA1	403116	G.34	6KGP63050X2XXCA1	403809	G.34	6KGP63350X9XXCB1	409656	G.34
6KGP43350X2XXCB1	409606	G.34	6KGP43F50X9XXA1	403290	G.34	6KGP63050X2XXCA1	403685	G.34	6KGP63450X2XBCB1	409678	G.34
6KGP43350X9RBCB1	409639	G.34	6KGP43F50X9XXA1	400412	G.34	6KGP63050X2XXCA1	403755	G.34	6KGP63450X2XXCB1	409664	G.34
6KGP43350X9RBCB1	409612	G.34	6KGP63015X1RBCA1	403822	G.34	6KGP63050X2XXCA1	403586	G.34	6KGP63450X9RBCB1	409671	G.34
6KGP43350X9RBCB1	409624	G.34	6KGP63015X1RXXA1	403714	G.34	6KGP63060X1RBCA1	403828	G.34	6KGP63450X9XXCB1	409657	G.34
6KGP43350X9XXCB1	409605	G.34	6KGP63015X1RXXA1	403768	G.34	6KGP63060X1RXXA1	403720	G.34	6KGP63500X1XBCA1	403674	G.34
6KGP43450X1RBCA1	403240	G.34	6KGP63015X1RXXA1	403615	G.34	6KGP63060X1RXXA1	403774	G.34	6KGP63500X1XXCA1	403577	G.34
6KGP43450X1RBCA1	402972	G.34	6KGP63015X1XBCA1	403795	G.34	6KGP63060X1XXCA1	403621	G.34	6KGP63500X2XBCA1	403696	G.34
6KGP43450X1XBCA1	403153	G.34	6KGP63015X1XBCA1	403642	G.34	6KGP63060X1XXCA1	403801	G.34	6KGP63500X2XXCB1	403597	G.34
6KGP43450X1XXCA1	402885	G.34	6KGP63015X1XXCA1	403741	G.34	6KGP63060X1XXCA1	403648	G.34	6KGP63500X8XBCA1	403658	G.34
6KGP43450X2RBCA1	403265	G.34	6KGP63015X1XXCA1	403545	G.34	6KGP63060X1XXCA1	403747	G.34	6KGP63550X1XBCA1	403675	G.34
6KGP43450X2RBCA1	402997	G.34	6KGP63015X2RBCA1	403831	G.34	6KGP63060X1XXCA1	403551	G.34	6KGP63550X1XXCA1	403578	G.34
6KGP43450X2RBCA1	403178	G.34	6KGP63015X2RXXA1	403723	G.34	6KGP63060X2RBCA1	403837	G.34	6KGP63550X2XBCA1	403697	G.34
6KGP43450X2XXCA1	402910	G.34	6KGP63015X2RXXA1	403777	G.34	6KGP63060X2RXXA1	403729	G.34	6KGP63550X2XXCB1	403598	G.34
6KGP43450X8RBCA1	403225	G.34	6KGP63015X2RXXA1	403624	G.34	6KGP63060X2RXXA1	403783	G.34	6KGP63550X8XBCA1	403659	G.34
6KGP43450X8RBCA1	402957	G.34	6KGP63015X2XBCA1	403804	G.34	6KGP63060X2RXXA1	403630	G.34	6KGP63550X8XXCA1	403562	G.34
6KGP43450X8XXCA1	403138	G.34	6KGP63015X2XBCA1	403678	G.34	6KGP63060X2XXCA1	403810	G.34	6KGP63650X1XBCA1	403676	G.34
6KGP43450X8XXCA1	402870	G.34	6KGP63015X2XXCA1	403750	G.34	6KGP63060X2XXCA1	403686	G.34	6KGP63650X1XXCA1	403579	G.34
6KGP43500X1RBCA1	403241	G.34	6KGP63015X2XXCA1	403581	G.34	6KGP63060X2XXCA1	403756	G.34	6KGP63650X2XBCA1	403698	G.34
6KGP43500X1RBCA1	402973	G.34	6KGP63020X1RBCA1	403823	G.34	6KGP63060X2XXCA1	403587	G.34	6KGP63650X2XXCA1	403599	G.34
6KGP43500X1RBCA1	403154	G.34	6KGP63020X1RXXA1	403715	G.34	6KGP63075X1RBCA1	403829	G.34	6KGP63650X8XBCA1	403660	G.34
6KGP43500X1XBCA1	402886	G.34	6KGP63020X1RXXA1	403769	G.34	6KGP63075X1RXXA1	403721	G.34	6KGP63650X8XXCA1	403563	G.34
6KGP43500X2RBCA1	403266	G.34	6KGP63020X1XXCA1	403616	G.34	6KGP63075X1XXCA1	403775	G.34	6KGP63750X1XBCA1	403677	G.34
6KGP43500X2RBCA1	402998	G.34	6KGP63020X1XXCA1	403796	G.34	6KGP63075X1XXCA1	403622	G.34	6KGP63750X1XXCA1	403580	G.34
6KGP43500X2XXCA1	403179	G.34	6KGP63020X1XXCA1	403643	G.34	6KGP63075X1XXCA1	403802	G.34	6KGP63750X2XBCA1	403699	G.34
6KGP43500X2XXCA1	402911	G.34	6KGP63020X1XXCA1	403742	G.34	6KGP63075X1XXCA1	403649	G.34	6KGP63750X2XXCB1	403600	G.34
6KGP43500X8RBCA1	403226	G.34	6KGP63020X1XXCA1	403546	G.34	6KGP63075X1XXCA1	403748	G.34	6KGP63750X8XBCA1	403661	G.34
6KGP43500X8RBCA1	402958	G.34	6KGP63020X2RBCA1	403832	G.34	6KGP63075X1XXCA1	403552	G.34	6KGP63750X8XXCA1	403564	G.34
6KGP43500X8XXCA1	403139	G.34	6KGP63020X2RXXA1	403724	G.34	6KGP63075X2RBCA1	403838	G.34	6KGP63750X8XXCA1	403662	G.34
6KGP43500X8XXCA1	402871	G.34	6KGP63020X2RXXA1	403778	G.34	6KGP63075X2RXXA1	403730	G.34	6KGP63900X1XBCA1	403565	G.34
6KGP43550X1RBCA1	403242	G.34	6KGP63020X2RXXA1	403625	G.34	6KGP63075X2RXXA1	403784	G.34	6KGP63900X2XBCA1	403700	G.34
6KGP43550X1RBCA1	402974	G.34	6KGP63020X2XXCA1	403805	G.34	6KGP63075X2XXCA1	403631	G.34	6KGP63900X2XXCB1	403601	G.34
6KGP43550X1XBCA1	403155	G.34	6KGP63020X2XXCA1	403679	G.34	6KGP63075X2XXCA1	403811	G.34	6KHFCM12	6KHFCM12	
6KGP43550X1XXCA1	402887	G.34	6KGP63020X2XXCA1	403751	G.34	6KGP63075X2XXCA1	403687	G.34	6KHFCM30	6KHFCM30	
6KGP43550X2RBCA1	403267	G.34	6KGP63020X2XXCA1	403582	G.34	6KGP63075X2XXCA1	403757	G.34	6KHFCM40	6KHFCM40	
6KGP43550X2RBCA1	402999	G.34	6KGP63025X1RBCA1	403824	G.34	6KGP63075X2XXCA1	403588	G.34	6KHFCM56	6KHFCM56	
6KGP43550X2XXCA1	403180	G.34	6KGP63025X1RXXA1	403716	G.34	6KGP63100X1RBCA1	403830	G.34	6KLP21001X9A1	404776	G.28
6KGP43550X2XXCA1	402912	G.34	6KGP63025X1RXXA1	403770	G.34	6KGP63100X1RXXA1	403722	G.34	6KLP21002X9A1	404777	G.28
6KGP43550X8RBCA1	403227	G.34	6KGP63025X1XXCA1	403617	G.34	6KGP63100X1XXCA1	403776	G.34	6KLP21003X9A1	404778	G.28
6KGP43550X8RBCA1	402959	G.34	6KGP63025X1XXCA1	403797	G.34	6KGP63100X1XXCA1	403623	G.34	6KLP212F5X9A1	404774	G.28
6KGP43550X8XXCA1	403140	G.34	6KGP63025X1XXCA1	403644	G.34	6KGP63100X1XXCA1	403803	G.34	6KLP212F50X9A1	404775	G.28
6KGP43550X8XXCA1	402872	G.34	6KGP63025X1XXCA1	403743	G.34	6KGP63100X1XXCA1	403650	G.34	6KLP23001X9A1	404781	G.28
6KGP43600X1RBCA1	403228	G.34	6KGP63025X1XXCA1	403547	G.34	6KGP63100X1XXCA1	403749	G.34	6KLP23002X9A1	404782	G.28
6KGP43600X1RBCA1	402960	G.34	6KGP63025X2RBCA1	403833	G.34	6KGP63100X1XXCA1	403553	G.34	6KLP23003X9A1	404783	G.28
6KGP43600X1XBCA1	403141	G.34	6KGP63025X2RXXA1	403725	G.34	6KGP63100X2RBCA1	403839	G.34	6KLP23005X9A1	404784	G.28
6KGP43600X1XBCA1	402873	G.34	6KGP63025X2RXXA1	403779	G.34	6KGP63100X2RXXA1	403731	G.34	6KLP23F3X9A1	404779	G.28
6KGP43600X2RBCA1	403268	G.34	6KGP63025X2RXXA1	403626	G.34	6KGP63100X2RXXA1	403785	G.34	6KLP23F50X9A1	404780	G.28
6KGP43600X2RBCA1	403094	G.34	6KGP63025X2XXCA1	403806	G.34	6KGP63100X2XXCA1	403632	G.34	6KLP43001X9A1	404786	G.28
6KGP43600X2XXCA1	403181	G.34	6KGP63025X2XXCA1	403682	G.34	6KGP63100X2XXCA1	403812	G.34	6KLP43002X9A1	404787	G.28
6KGP43600X2XXCA1	402913	G.34	6KGP63025X2XXCA1	403752	G.34	6KGP63100X2XXCA1	403688	G.34	6KLP43003X9A1	404788	G.28
6KGP43650X1RBCA1	403229	G.34	6KGP63025X2XXCA1	403583	G.34	6KGP63100X2XXCA1	403758	G.34	6KLP43005X9A1	404789	G.28
6KGP43650X1RBCA1	402961	G.34	6KGP63030X1RBCA1	403825	G.34	6KGP63100X2XXCA1	403589	G.34	6KLP43007X9A1	404790	G.28
6KGP43650X1XBCA1	403142	G.34	6KGP63030X1RXXA1	403717	G.34	6KGP63125X2XBCB1	409672	G.34	6KLP43010X9A1	404791	G.28
6KGP43650X1XXCA1	402874	G.34	6KGP63030X1RXXA1	403771	G.34	6KGP63125X2XXCB1	409658	G.34	6KLP43015X9A1	404792	G.28

Power Electronics Alphabetical Index

Alphabetical index

Intro

A

B

C

D

E

F

G

H

I

X

Cat. no.	Ref. no	Cat. pg	Cat. no.	Ref. no	Cat. pg	Cat. no.	Ref. no	Cat. pg	Cat. no.	Ref. no	Cat. pg
7KEMC3080	168821	G.72	7KFP53005K9RXA1	168748	G.18	7KLP23004K9RBA1	168613	G.8	OPCCOVER51	404847	G.41/G.59
7KEMC3180	168822	G.72	7KFP53007K4RXA1	168777	G.18	7KLP23004K9RBA1	168622	G.8	OPCDEV	404818	G.41/G.59
7KEMC3300	168823	G.72	7KFP53007K5RXA1	168905	G.18	7KLP23005K9RBA1	168614	G.8	OPCEIP	404820	G.41/G.59
7KEMC3500	168829	G.72	7KFP53007K9RXA1	168749	G.18	7KLP23005K9RBA1	168623	G.8	OPCENC	404819	G.41/G.59
7KFP21001K4RXA1	168758	G.18	7KFP53007K4RXA1	168772	G.18	7KLP23007K9RBA1	168615	G.8	OPCGPIO	404821	G.41/G.59
7KFP21001K5RXA1	168780	G.18	7KFP53007K5RXA1	168900	G.18	7KLP23007K9RBA1	168624	G.8	OPCLON	404823	G.41/G.59
7KFP21001K9RXA1	168717	G.18	7KFP53007K9RXA1	168744	G.18	7KLP2300K4XXA1	168662	G.8	OPCMBTCP	404824	G.41/G.59
7KFP21002K4RXA1	168759	G.18	7KFP53011K4RXA1	168778	G.18	7KLP2300K45XXA1	168696	G.8	OPCPDP	404848	G.41/G.59
7KFP21002K5RXA1	168781	G.18	7KFP53011K5RXA1	168906	G.18	7KLP2300K49XXA1	168617	G.8	OPCPED41H	409506	G.41/G.59
7KFP21002K9RXA1	168718	G.18	7KFP53011K9RXA1	168750	G.18	7KLP2300K74XXA1	168663	G.8	OPCPED42H	409507	G.41/G.59
7KFP21007K4RXA1	168757	G.18	7KFP53015K2RXA1	168929	G.18	7KLP2300K75XXA1	168697	G.8	OPCPMK15	404840	G.41/G.59
7KFP21007K5RXA1	168779	G.18	7KFP53015K9RXA1	168751	G.18	7KLP2300K79XXA1	168618	G.8	OPCPMK21	404841	G.41/G.59
7KFP21007K9RXA1	168716	G.18	7KFP53018K2RXA1	168930	G.18	7KLP23011K9RBA1	168616	G.8	OPCPMK22	404842	G.41/G.59
7KFP23001K4RXA1	168761	G.18	7KFP53018K9RXA1	168752	G.18	7KLP23011K9RBA1	168625	G.8	OPCPMK31	404843	G.41/G.59
7KFP23001K5RXA1	168783	G.18	7KFP53020K2RXA1	168931	G.18	7KLP23001K4RBA1	168670	G.8	OPCPMK32	404844	G.41/G.59
7KFP23001K9RXA1	168720	G.18	7KFP53022K9RXA1	168753	G.18	7KLP43001K4RBA1	168669	G.8	OPCPRGIO	409552	G.41/G.59
7KFP23002K4RXA1	168762	G.18	7KFP53030K2RXA1	168932	G.18	7KLP43001K4XBA1	168677	G.8	OPCPRT	404825	G.41/G.59
7KFP23002K5RXA1	168784	G.18	7KFP53030K9RXA1	168754	G.18	7KLP43001K4XXA1	168676	G.8	OPCPRES	404852	G.41/G.59
7KFP23002K9RXA1	168721	G.18	7KFP53037K2RXA1	168933	G.18	7KLP43001K5RBA1	168704	G.8	OPCRLV	404849	G.41/G.59
7KFP23004K4RXA1	168763	G.18	7KFP53037K9RXA1	168755	G.18	7KLP43001K5RBA1	168703	G.8	OPCSAFE	404853	G.41/G.59
7KFP23004K5RXA1	168785	G.18	7KFP53045K2RXA1	168934	G.18	7KLP43001K5XBA1	168711	G.8	OPCSTERM	404822	G.41/G.59
7KFP23004K9RXA1	168722	G.18	7KFP53045K9RXA1	168756	G.18	7KLP43001K5XXA1	168710	G.8	OPCTERM9	409562	G.41/G.59
7KFP23005K4RXA1	168764	G.18	7KFP53052K2RXA1	168935	G.18	7KLP43001K9RBA1	168628	G.8	OPCUSB	404861	G.41/G.59
7KFP23005K5RXA1	168786	G.18	7KFP53075K2RXA1	168936	G.18	7KLP43001K9RBA1	168627	G.8	OPCUSB6X	404860	G.41/G.59
7KFP23005K9RXA1	168723	G.18	7KFP53090K2RXA1	168937	G.18	7KLP43001K9RBA1	168639	G.8	QC118018XA1	872869	H.13
7KFP23007K2RXA1	168907	G.18	7KFP53110K2RXA1	168938	G.18	7KLP43001K9XXA1	168638	G.8	QC118034XA1	872870	H.13
7KFP23007K9RXA1	168724	G.18	7KFPBAC	168807	G.23	7KLP43002K4RBA1	168671	G.8	QC118042XA1	872871	H.13
7KFP23007K4RXA1	168760	G.18	7KFPCCRTL	168838	G.23	7KLP43002K4XBA1	168678	G.8	QC118048XA1	872872	H.13
7KFP23007K5RXA1	168782	G.18	7KFPDVE	168806	G.23	7KLP43002K5RBA1	168705	G.8	QC118060XA1	872873	H.13
7KFP23007K9RXA1	168719	G.18	7KFPFCAT	168802	G.23	7KLP43002K5XBA1	168712	G.8	QC118075XA1	872874	H.13
7KFP23011K2RXA1	168908	G.18	7KFPFIP	168805	G.23	7KLP43002K9RBA1	168629	G.8	QC118085XA1	872875	H.13
7KFP23011K9RXA1	168725	G.18	7KFPGPI0	168837	G.23	7KLP43002K9RBA1	168640	G.8	QC118100XA1	872876	H.13
7KFP23015K2RXA1	168909	G.18	7KFPMBTCP	168808	G.23	7KLP43004K4RBA1	168672	G.8	QC118140XA1	872877	H.13
7KFP23015K9RXA1	168726	G.18	7KFPMSW4	168839	G.23	7KLP43004K4XBA1	168679	G.8	QC118170XA1	872878	H.13
7KFP23018K2RXA1	168910	G.18	7KFPMSW5	168840	G.23	7KLP43004K5RBA1	168706	G.8	QC118200XA1	872879	H.13
7KFP23018K9RXA1	168727	G.18	7KFPMPDP	168803	G.23	7KLP43004K5XBA1	168713	G.8	QC128018XA1	873096	H.13
7KFP23022K2RXA1	168911	G.18	7KFPMPRT	168804	G.23	7KLP43004K9RBA1	168630	G.8	QC128034XA1	873098	H.13
7KFP23022K9RXA1	168728	G.18	7KFPPTMK4	168844	G.23	7KLP43004K9RBA1	168641	G.8	QC128042XA1	873100	H.13
7KFP23030K2RXA1	168912	G.18	7KFPPTMK5	168845	G.23	7KLP43005K4RBA1	168673	G.8	QC128048XA1	873102	H.13
7KFP23037K2RXA1	168913	G.18	7KFPPTMK6	168846	G.23	7KLP43005K4XBA1	169000	G.8	QC128060XA1	873073	H.13
7KFP23045K2RXA1	168914	G.18	7KFPPTMK7	168847	G.23	7KLP43005K5RBA1	168707	G.8	QC128075XA1	873105	H.13
7KFP23055K2RXA1	168915	G.18	7KGTWDEV	168801	G.12	7KLP43005K5XBA1	168714	G.8	QC128085XA1	873107	H.13
7KFP23075K2RXA1	168916	G.18	7KGTWDPD	168800	G.12	7KLP43005K9RBA1	168631	G.8	QC128100XA1	873109	H.13
7KFP43001K4RXA1	168766	G.18	7KLP21001K4RBA1	168651	G.8	7KLP43005K9XBA1	168642	G.8	QC128140XA1	873111	H.13
7KFP43001K5RXA1	168788	G.18	7KLP21001K4RBA1	168650	G.8	7KLP43007K4RBA1	168674	G.8	QC128170XA1	873113	H.13
7KFP43001K9RXA1	168730	G.18	7KLP21001K4XBA1	168656	G.8	7KLP43007K4XBA1	168681	G.8	QC128200XA1	873115	H.13
7KFP43002K4RXA1	168767	G.18	7KLP21001K4XXA1	168655	G.8	7KLP43007K5RBA1	168708	G.8	QC318018XA1	872153	H.13
7KFP43002K5RXA1	168789	G.18	7KLP21001K5RBA1	168685	G.8	7KLP43007K5XBA1	168715	G.8	QC318034XA1	872154	H.13
7KFP43002K9RXA1	168731	G.18	7KLP21001K5RBA1	168684	G.8	7KLP43007K9RBA1	168632	G.8	QC318042XA1	872155	H.13
7KFP43004K4RXA1	168768	G.18	7KLP21001K5XBA1	168690	G.8	7KLP43007K9RBA1	168643	G.8	QC318048XA1	872159	H.13
7KFP43004K5RXA1	168790	G.18	7KLP21001K5XXA1	168689	G.8	7KLP43007K4RBA1	168668	G.8	QC318060XA1	872173	H.13
7KFP43004K9RXA1	168732	G.18	7KLP21001K9RBA1	168603	G.8	7KLP43007K4XXA1	168675	G.8	QC318075XA1	872175	H.13
7KFP43005K4RXA1	168769	G.18	7KLP21001K9RBA1	168602	G.8	7KLP43007K5RBA1	168702	G.8	QC318085XA1	872183	H.13
7KFP43005K5RXA1	168791	G.18	7KLP21001K9RBA1	168608	G.8	7KLP43007K5XXA1	168709	G.8	QC318100XA1	872184	H.13
7KFP43005K9RXA1	168733	G.18	7KLP21001K9XXA1	168607	G.8	7KLP43007K9RBA1	168626	G.8	QC318140XA1	872185	H.13
7KFP43007K4RXA1	168770	G.18	7KLP21002K4RBA1	168652	G.8	7KLP43007K9XXA1	168637	G.8	QC318170XA1	872186	H.13
7KFP43007K5RXA1	168792	G.18	7KLP21002K4XBA1	168657	G.8	7KLP43011K9RBA1	168633	G.8	QC318200XA1	872187	H.13
7KFP43007K9RXA1	168734	G.18	7KLP21002K5RBA1	168666	G.8	7KLP43011K9RBA1	168644	G.8	QC328018XA1	873097	H.13
7KFP43007K4RXA1	168765	G.18	7KLP21002K5XBA1	168691	G.8	7KLP43015K9RBA1	168634	G.8	QC328034XA1	873099	H.13
7KFP43007K5RXA1	168787	G.18	7KLP21002K9RBA1	168604	G.8	7KLP43015K9RBA1	168645	G.8	QC328042XA1	873101	H.13
7KFP43007K9RXA1	168729	G.18	7KLP21002K9RBA1	168609	G.8	7KLP43018K9RBA1	168635	G.8	QC328048XA1	873103	H.13
7KFP43011K4RXA1	168771	G.18	7KLP21004K4RBA1	168658	G.8	7KLP43018K9RBA1	168646	G.8	QC328060XA1	873104	H.13
7KFP43011K5RXA1	168793	G.18	7KLP21004K5RBA1	168692	G.8	7KLP43022K9RBA1	168636	G.8	QC328075XA1	873106	H.13
7KFP43011K9RXA1	168735	G.18	7KLP21004K9RBA1	168610	G.8	7KLP43022K9RBA1	168647	G.8	QC328085XA1	873108	H.13
7KFP43015K2RXA1	168917	G.18	7KLP2100K4RBA1	168648	G.8	7KLPBR033P300	168814	G.8	QC328100XA1	873110	H.13
7KFP43015K9RXA1	168736	G.18	7KLP2100K4XXA1	168653	G.8	7KLPBR050P200	168813	G.8	QC328140XA1	873112	H.13
7KFP43018K2RXA1	168918	G.18	7KLP2100K45RBA1	168682	G.8	7KLPBR100P200	168812	G.8	QC328170XA1	873114	H.13
7KFP43018K9RXA1	168737	G.18	7KLP2100K45XXA1	168687	G.8	7KLPBHVAC	168834	G.12	QC328200XA1	873116	H.13
7KFP43020K2RXA1	168919	G.18	7KLP2100K49RBA1	168600	G.8	7KLPPLV	168832	G.12	QL128023DA1	872221	H.14
7KFP43022K9RXA1	168739	G.18	7KLP2100K49XXA1	168605	G.8	7KRMKPD1	168830	G.12/G.23	QL128043DA1	872239	H.14
7KFP43030K2RXA1	168920	G.18	7KLP2100K74RBA1	168649	G.8	7KRMKPD2	168831	G.12/G.23	QL128050DA1	872241	H.14
7KFP43030K9RXA1	168739	G.18	7KLP2100K74XXA1	168654	G.8	7KUSB	168811	G.12/G.23	QL128053DA1	872243	H.14
7KFP43037K2RXA1	168921	G.18	7KLP2100K75RBA1	168683	G.8	DEPLTACL1P	404804	G.30	QL128076DA1	872245	H.14
7KFP43037K9RXA1	168740	G.18	7KLP2100K75XXA1	168688	G.8	DEPLTACL2P	404805	G.30	QL128097DA1	872246	H.14
7KFP43045K2RXA1	168922	G.18	7KLP2100K79RBA1	168601	G.8	DEPLTACL3P	404803	G.30	QL128100DA1	872247	H.14
7KFP43045K9RXA1	168741	G.18	7KLP2100K79XXA1	168606	G.8	NEMA1ACA2	404831	G.41/G.59	QL128105DA1	872248	H.14
7KFP43055K2RXA1	168923	G.18	7KLP23001K4RBA1	168659	G.8	NEMA1ACA3	404832	G.41/G.59	QL128145DA1	872249	H.14
7KFP43075K2RXA1	168924	G.18	7KLP23001K4XBA1	168665	G.8	NEMA1ACB3	404833	G.41/G.59	QL128170DA1	872256	H.14
7KFP43090K2RXA1	168925	G.18	7KLP23001K4XXA1	168664	G.8	NEMA1ACB4	404834	G.41/G.59	QL1281K0DA1	872306	H.14
7KFP43110K2RXA1	168926	G.18	7KLP23001K5RBA1	168693	G.8	NEMA1ACB5	404835	G.41/G.59	QL128200DA1	872258	H.14
7KFP43130K2RXA1	168927	G.18	7KLP23001K5XBA1	168699	G.8	NEMA1ACCA	404836	G.41/G.59	QL128220DA1	872274	H.14
7KFP43160K2RXA1	168928	G.18	7K								

Power Electronics Alphabetical Index

Cat. no.	Ref. no	Cat. pg	Cat. no.	Ref. no	Cat. pg	Cat. no.	Ref. no	Cat. pg	Cat. no.	Ref. no	Cat. pg
QL21X430DA1	872322	H.14	QL42X380DA1	873172	H.14						
QL21X620DA1	872324	H.14	QL42X430DA1	873173	H.14						
QL21X650DA1	872328	H.14	QL42X620DA1	873174	H.14						
QL21X790DA1	872330	H.14	QL42X650DA1	873175	H.14						
QL21X930DA1	872332	H.14	QL42X790DA1	873176	H.14						
QL22B023DA1	873119	H.14	QL42X930DA1	873177	H.14						
QL22B043DA1	873120	H.14	QODEV	872379	H.13/H.17						
QL22B050DA1	873121	H.14	QOEIP	872378	H.13/H.17						
QL22B053DA1	873122	H.14	QOFPROTXB	872394	H.13/H.17						
QL22B076DA1	873118	H.14	QOFPROTXL2	872395	H.13/H.17						
QL22B097DA1	873123	H.14	QOFPROTXL3	872396	H.13/H.17						
QL22B100DA1	873124	H.14	QOFPROTXL4	872399	H.13/H.17						
QL22B105DA1	873125	H.14	QOMB	872383	H.13/H.17						
QL22B145DA1	873126	H.14	QOMBTCP	872384	H.13/H.17						
QL22B170DA1	873127	H.14	QOPDP	872386	H.13/H.17						
QL22B1K0DA1	873137	H.14	QOPRT	872387	H.13/H.17						
QL22B200DA1	873117	H.14	QORCPXB	872392	H.13/H.17						
QL22B220DA1	873128	H.14	QORCPXL	872391	H.13/H.17						
QL22B255DA1	873129	H.14	QOUSB	872388	H.13/H.17						
QL22B350DA1	873130	H.14	QS11B018XA1	872411	H.13						
QL22B425DA1	873131	H.14	QS11B034XA1	872858	H.13						
QL22B500DA1	873132	H.14	QS11B042XA1	872859	H.13						
QL22B580DA1	873133	H.14	QS11B048XA1	872861	H.13						
QL22B700DA1	873134	H.14	QS11B060XA1	872862	H.13						
QL22B820DA1	873135	H.14	QS11B075XA1	872863	H.13						
QL22B920DA1	873136	H.14	QS11B085XA1	872864	H.13						
QL22X1K2DA1	873146	H.14	QS11B100XA1	872865	H.13						
QL22X1K4DA1	873147	H.14	QS11B140XA1	872866	H.13						
QL22X1K6DA1	873148	H.14	QS11B170XA1	872867	H.13						
QL22X255DA1	873138	H.14	QS11B200XA1	872868	H.13						
QL22X360DA1	873139	H.14	QS12B018XA1	873074	H.13						
QL22X380DA1	873140	H.14	QS12B034XA1	873075	H.13						
QL22X430DA1	873141	H.14	QS12B042XA1	873076	H.13						
QL22X620DA1	873142	H.14	QS12B048XA1	873077	H.13						
QL22X650DA1	873143	H.14	QS12B060XA1	873078	H.13						
QL22X790DA1	873144	H.14	QS12B075XA1	873079	H.13						
QL22X930DA1	873145	H.14	QS12B085XA1	873080	H.13						
QL41B023DA1	872337	H.14	QS12B100XA1	873081	H.13						
QL41B043DA1	872338	H.14	QS12B140XA1	873082	H.13						
QL41B050DA1	872339	H.14	QS12B170XA1	873083	H.13						
QL41B053DA1	872340	H.14	QS12B200XA1	873084	H.13						
QL41B076DA1	872342	H.14	QS31B018XA1	872078	H.13						
QL41B097DA1	872343	H.14	QS31B034XA1	872080	H.13						
QL41B100DA1	872344	H.14	QS31B042XA1	872085	H.13						
QL41B105DA1	872346	H.14	QS31B048XA1	872090	H.13						
QL41B145DA1	872347	H.14	QS31B060XA1	872099	H.13						
QL41B170DA1	872351	H.14	QS31B075XA1	872118	H.13						
QL41B1K0DA1	872363	H.14	QS31B085XA1	872123	H.13						
QL41B200DA1	872352	H.14	QS31B100XA1	872124	H.13						
QL41B220DA1	872353	H.14	QS31B140XA1	872125	H.13						
QL41B255DA1	872354	H.14	QS31B170XA1	872135	H.13						
QL41B350DA1	872356	H.14	QS31B200XA1	872146	H.13						
QL41B425DA1	872357	H.14	QS32B018XA1	873085	H.13						
QL41B500DA1	872358	H.14	QS32B034XA1	873086	H.13						
QL41B580DA1	872359	H.14	QS32B042XA1	873087	H.13						
QL41B700DA1	872360	H.14	QS32B048XA1	873088	H.13						
QL41B820DA1	872361	H.14	QS32B060XA1	873089	H.13						
QL41B920DA1	872362	H.14	QS32B075XA1	873090	H.13						
QL41X1K2DA1	872373	H.14	QS32B085XA1	873091	H.13						
QL41X1K4DA1	872374	H.14	QS32B100XA1	873092	H.13						
QL41X1K6DA1	872376	H.14	QS32B140XA1	873093	H.13						
QL41X255DA1	872364	H.14	QS32B170XA1	873094	H.13						
QL41X360DA1	872365	H.14	QS32B200XA1	873095	H.13						
QL41X380DA1	872366	H.14	RMACLP1	404806	G.30						
QL41X430DA1	872368	H.14	RMKYPDAC	404851	G.30						
QL41X620DA1	872369	H.14	RMKYPDACLP1	404797	G.30						
QL41X650DA1	872370	H.14									
QL41X790DA1	872371	H.14									
QL41X930DA1	872372	H.14									
QL42B023DA1	873149	H.14									
QL42B043DA1	873150	H.14									
QL42B050DA1	873151	H.14									
QL42B053DA1	873152	H.14									
QL42B076DA1	873153	H.14									
QL42B097DA1	873154	H.14									
QL42B100DA1	873155	H.14									
QL42B105DA1	873156	H.14									
QL42B145DA1	873157	H.14									
QL42B170DA1	873158	H.14									
QL42B1K0DA1	873169	H.14									
QL42B200DA1	873159	H.14									
QL42B220DA1	873160	H.14									
QL42B255DA1	873161	H.14									
QL42B350DA1	873162	H.14									
QL42B425DA1	873163	H.14									
QL42B500DA1	873164	H.14									
QL42B580DA1	873165	H.14									
QL42B700DA1	873166	H.14									
QL42B820DA1	873167	H.14									
QL42B920DA1	873168	H.14									
QL42X1K2DA1	873178	H.14									
QL42X1K4DA1	873179	H.14									
QL42X1K6DA1	873180	H.14									
QL42X255DA1	873170	H.14									
QL42X360DA1	873171	H.14									



Since Thomas Edison patented the world's first circuit breaker, Industrial Solutions has been transforming the future of electrification. We design electrical solutions at the crossroads of digital and industrial – smart, rugged and equipped to control electricity from the grid to its point of use. Every day, we partner with our customers to solve their toughest energy challenges and reimagine industry in a way that only the world's digital industrial company can.

Belgium

GE Industrial Belgium
Nieuwevaart 51
B-9000 Gent
Tel. +32 (0)9 265 21 11

Finland

GE Industrial Solutions
Kuortaneenkatu 2
FI-00510 Helsinki
Tel. +358 (0)10 394 3760

France

GE Industrial Solutions
204, Rue du Rond-Point du Pont de Sèvres
F-92100 Boulogne-Billancourt
Tel. +33 (0)800 912 816

Germany

GE Industrial Solutions
Robert-Bosch Str. 3
D-50354 Hürth-Efferen
Tel. +49 (0) 2233/ 9719-0

Hungary

GE Hungary Kft.
Váci ut 81-83.
H-1139 Budapest
Tel. +36 1 447 6050

Italy

GE Industrial Solutions
Centro Direzionale Colleoni
Via Paracelso 16
Palazzo Andromeda B1
I-20864 Agrate Brianza (MB)
Tel. +39 039 637 371

Netherlands

GE Industrial Solutions
Parallelweg 10
NL-7482 CA Haaksbergen
Tel. +31 (0)53 573 03 03

North Africa

General Electric International,
sq Inc. (Succursale)
Crystal Building 3,
3rd Floor, Marina Casablanca,
20050 Casablanca, Morocco
Tel. +212 529 025 502

Norway

GE Industrial Solutions
Drammensveien 165
0277 Oslo
Tel. +47 (0)8 001 72 56

Poland

GE Power Controls
Gdanski Business Centre
Inflancka 4C, bud. D
00-189 Warszawa
Tel. +48 22 520 53 53

Rudawka 96
43-382 Bielsko-Biała
Tel. +48 33 828 62 33

Russia

GE Industrial Solutions
27/8, Electrozavodskaya street
Moscow, 107023
Tel. +7 495 937 11 11

South Africa

GE Industrial Solutions
Unit 4, 130 Gazelle Avenue
Corporate Park Midrand 1685
P.O. Box 76672 Wendywood 2144
Tel. +27 11 238 3000

Spain

GE POWER CONTROLS IBÉRICA, S.L.
Calle Miño 122 Naves E-F
Polígono Industrial Santa Margarita
08223 Terrassa (Barcelona)
Tel. +34 900 993 625

Sweden

GE Industrial Slutions
Vendevägen 89
SE-182 32 Danderyd
Tel. +46 (0)20 79 16 70

United Arab Emirates

GE Industrial Solutions
Injaz Building, 3rd Floor
Dubai Internet City
PO Box 11549, Dubai
Tel. +971 4 4546912

United Kingdom

GE Industrial Solutions
2 The Arena, Downshire Way
Bracknell, Berkshire
RG12 1PU
Tel. +44 (0)800 587 1239

Asia and Far East

GE Industrial Solutions
4F, Building 2, CTP, No1 Hua Tuo Rd.
Zhang Jiang Hi-Tech Park
Shangai, China 201203
Tel. +86 21 3877 7888

Latin America

GE Industrial Solutions
790 N.W. 107th Avenue, Suite 200
Miami, FL 33172 USA
Tel. +1 305 551 5155

North America

GE Industrial Solutions
41 Woodford Avenue
Plainville CT, USA 06062
and
12305 Kurland Drive
Houston, TX USA 77034
Tel. +1 800-431-7867

